

(No Model.)

A. J. MYERS.  
FLAT IRON HEATER.

No. 525,427.

Patented Sept. 4, 1894.

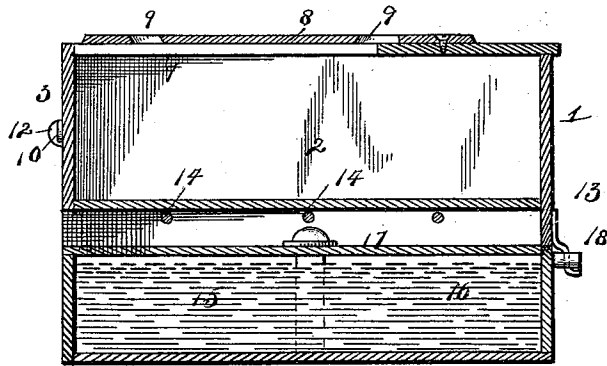
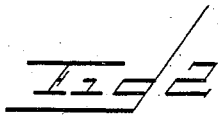
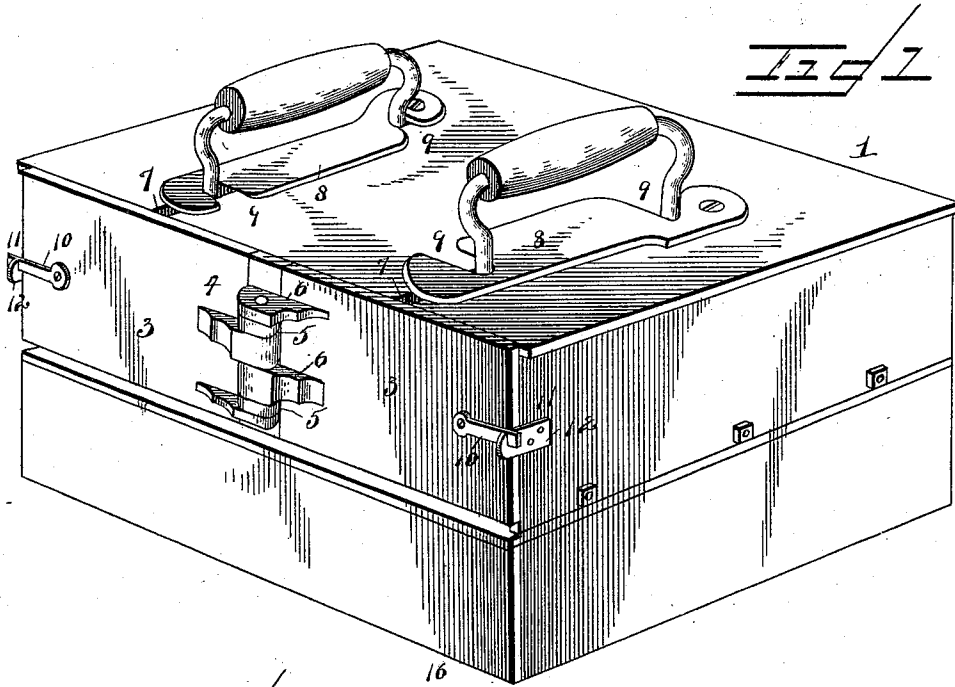

Inventor  
*Adeline J. Myers*

Witnesses

*W. O. Schneider*  
*W. B. Hoff*

By her Attorneys.

*C. A. Snow & Co*

# UNITED STATES PATENT OFFICE.

ADELINE J. MYERS, OF INDUSTRY, ILLINOIS.

## FLAT-IRON HEATER.

SPECIFICATION forming part of Letters Patent No. 525,427, dated September 4, 1894.

Application filed September 7, 1893. Serial No. 484,982. (No model.)

*To all whom it may concern:*

Be it known that I, ADELINE J. MYERS, a citizen of the United States, residing at Industry, in the county of McDonough and State of Illinois, have invented a new and useful Flat-Iron Heater, of which the following is a specification.

My invention relates to a flat-iron heater, and has for its object to provide a simple, cheap and portable device embodying a heater and a receptacle or holder for the irons, the latter being detachable from the heater to enable it to be used in connection with an ordinary heating stove.

Other objects and advantages of my invention will appear in the following description and novel features thereof will be particularly pointed out in the appended claim.

In the drawings: Figure 1 is a perspective view of a heating apparatus embodying my invention. Fig. 2 is a vertical, central section of the same to show the depending flanges of the receptacle or holder and the manner of connecting the receptacle to the heater.

Similar numerals of reference indicate corresponding parts in both figures of the drawings.

1 designates the receptacle or holder which may be divided by means of vertical longitudinally disposed partitions 2 to form any desired number of compartments for the reception of irons. In the drawings I have illustrated a receptacle provided with two compartments which are closed at their front ends by the vertically hinged doors 3, mounted upon a common hinge-pin 4 which is carried by the fixed eyes 5. The perforated ears 6 which receive the hinge-pin are set out or offset from the plane of the doors to enable either door to fold flat against the other when open. The top of the receptacle is provided at the center of each compartment with a longitudinally disposed handle-receiving slot 7, which opens at the front of the receptacle to enable the handles of the irons to be inserted at this point. These slots are covered, and the handles of the irons are locked in place, by the closing plates 8 which are pivoted to the top of the receptacle and are

provided in their edges with the flared notches 9 to receive the standards of the handles. Latches 10 are pivoted to the doors near their outer or free ends to engage notches 11 in the catch plates 12 which are secured to the sides of the receptacle. The receptacle or holder is provided upon three sides with a depending flange or rim 13, such part being omitted at the front or the portion closed by the hinged doors, and the portions of said flange or rim at the sides of the receptacle are connected by the transversely disposed tie-bolts 14 which are arranged parallel with and contiguous to the bottom of the receptacle.

15 represents a heater having the box or body portion 16 and the burners 17 which correspond in number to the compartments of the receptacle. The receptacle is hinged to the box of the heater at its rear side by means of the hook-hinges 18 which enable the receptacle to be detached from the heater when it is desired to use the former in connection with an ordinary stove or other heating device.

The operation of the improved heating apparatus will be readily understood from the foregoing description, and it will be noted that the depending flange or rim of the receptacle confines and concentrates the heat upon the bottom of the receptacle thus utilizing all of the heat produced and resulting in an economization of fuel.

The arrangement of doors enables either of the compartments to be opened to its full width to receive an iron which corresponds in width to the compartment.

It will be understood that the number of compartments may be increased to receive any desired number of irons and that various other changes in the form, proportion and minor details of construction may be resorted to without departing from the spirit or sacrificing any of the advantages of my invention.

Having thus described my invention, I claim—

In a device of the class described, the combination with a heater, of a superjacent, co-extensive receptacle hinged at its rear side to the heater and provided with a closed bottom,

and a flange depending below the plane of the  
bottom, extending around three sides, and  
resting upon the upper surface of the heater,  
and doors closing the front open side of the  
5 receptacle and terminating at their lower  
edges flush with the plane of the bottom of the  
receptacle, substantially as specified.

In testimony that I claim the foregoing as  
my own I have hereto affixed my signature in  
the presence of two witnesses.

ADELINE J. MYERS.

Witnesses:

J. T. PITTMAN,  
JOHN GILSON.