



(12) **EUROPEAN PATENT APPLICATION**

(43) Date of publication:
30.11.2005 Bulletin 2005/48

(51) Int Cl.7: **G07F 17/32**

(21) Application number: **05011457.8**

(22) Date of filing: **27.05.2005**

(84) Designated Contracting States:
AT BE BG CH CY CZ DE DK EE ES FI FR GB GR HU IE IS IT LI LT LU MC NL PL PT RO SE SI SK TR
Designated Extension States:
AL BA HR LV MK YU

- **Hatakeyama, Daisuke**
Tokyo 135-0063 (JP)
- **Itagaki, Takehisa**
Tokyo 135-0063 (JP)
- **Kitani, Hirokazu**
Tokyo 135-0063 (JP)

(30) Priority: **27.05.2004 JP 2004157923**

(74) Representative: **HOFFMANN EITL**
Patent- und Rechtsanwälte
Arabellastrasse 4
81925 München (DE)

(71) Applicant: **Aruze Corp.**
Tokyo 135-0063 (JP)

(72) Inventors:
• **Isogai, Ryo**
Tokyo 135-0063 (JP)

(54) **Gaming machine**

(57) A gaming machine includes: a display that displays a game screen having a plurality of display areas provided with a plurality of symbol display areas; lottery means for performing a lottery to determine symbols to be displayed in each of the symbol display areas from among a plurality of symbols; and a controller that controls the display to display the symbols to be stopped in each of the symbol display areas after variably displaying the plurality of symbols in each of the symbol display areas, wherein when a predetermined combination of the symbols is determined by the lottery means to be displayed in at least one of the display areas, the controller controls the display to replace the predetermined combination of the symbols into a different symbol different from the symbols in the predetermined combination after displaying the symbols determined by the lottery means to be stopped in each of the symbol display areas.

FIG. 3

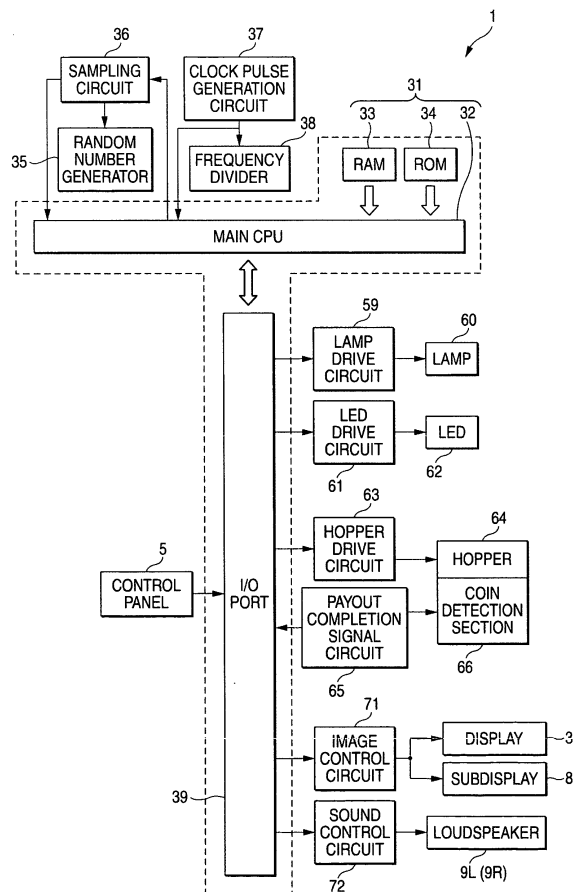

DescriptionBACKGROUND OF THE INVENTION

Field of the Invention

[0001] The present invention relates to a gaming machine such as a slot machine in which a plurality of symbols arranged on a plurality of rows are variably displayed.

Description of the Related Art

[0002] Hitherto, a slot machine has been known as a gaming machine for paying out game medium used with a game, such as medals or coins (which will be hereinafter referred to as "coins"), to a player in response to the winning state of the game. There are conventionally provided slot machines of a type having a plurality of reels (mechanical reels) each with symbols placed on the outer peripheral surface, and slot machines of a type having a plurality of reels (video reels) displayed on an image display. In the slot machines having the video reels, when a player performs predetermined operation, each of the reels on the display start to scroll and the symbols arranged in a predetermined order on each of the reels are displayed circularly. When all of the reels stop, coins are paid out in response to the combination of the symbols on activated pay lines (pay lines). An example of a conventional slot machine having video reels is disclosed, for example, in an international patent publication No. WO 00/32286 (a publication number of the Japanese national phase of which is JP-A-2002-537874).

SUMMARY OF THE INVENTION

[0003] However, in the slot machines in related arts including the slot machine disclosed in JP-A-2002-537874, the number of coins to be paid out is determined by exactly following the symbol pattern of the stopped reels (combination of the stopped symbols) and therefore the time interval between the instant at which the reels stop and the instant at which coins are paid out is a very boring time for a player. Thus, players who seek for more excitement are not satisfied with such a conventional gaming machine and are expecting for an introduction of a new gaming machine.

[0004] It is therefore one of objects of the present invention to provide a gaming machine that provides improved amusement.

According to one aspect of the invention, there is provided a gaming machine including: a display that displays a game screen having a plurality of display areas provided with a plurality of symbol display areas; lottery means for performing a lottery to determine symbols to be displayed in each of the symbol display areas from among a plurality of symbols; and a controller that con-

trols the display to display the symbols determined by the lottery means to be stopped in each of the symbol display areas after variably displaying the plurality of symbols in each of the symbol display areas, wherein when a predetermined combination of the symbols is determined by the lottery means to be displayed in at least one of the symbol display areas, the controller controls the display to replace the predetermined combination of the symbols into a different symbol different from the symbols in the predetermined combination after displaying the symbols determined by the lottery means to be stopped in each of the symbol display areas.

BRIEF DESCRIPTION OF THE DRAWINGS

[0005] These and other objects and advantages of the present invention will be more fully apparent from the following detailed description taken in conjunction with the accompanying drawings, in which:

FIG. 1 is a general perspective view to show a slot machine according to an embodiment of the invention;

FIG. 2 is a drawing to show button layout of a control panel;

FIG. 3 is a block diagram to show the slot machine centering on the internal configuration thereof;

FIG. 4 is a block diagram to show an example of the internal configuration of an image control circuit;

FIG. 5 is a drawing to show a game screen of a display;

FIG. 6 is a drawing to show symbols displayed on the display;

FIG. 7A and FIG. 7B are drawings to show examples of pay lines of the slot machine;

FIG. 8 is a drawing to show the symbol arrangement of the slot machine according to the embodiment of the invention;

FIG. 9 is a flowchart to show the game progress of the slot machine;

FIG. 10 is a drawing to show the symbol arrangement on the display in a state in which an effective display sequence is displayed in a display area C;

FIG. 11 is a drawing to show the symbol arrangement on the display after the effective display sequence in FIG. 10 is replaced;

FIG. 12 is a drawing to show the symbol arrangement on the display in a state in which an effective display sequence is not displayed in the display area C;

FIG. 13 is a drawing to show an example of the game screen where a predetermined combination of symbols (T11, T10, and T9) are arranged in a predetermined symbol display areas (C1-C3);

FIG. 14 is a drawing to show an example of the game screen where the predetermined combination of symbols are replaced into a different symbol (symbol T2);

FIG. 15 is a drawing to show another example of the game screen where the predetermined combination of symbols are replaced into a different symbol other than the symbol T2, which is a symbol T4; and

FIG. 16 is a drawing to show an example of the game screen where the replaced symbol T2 is displayed enlarged.

DETAILED DESCRIPTION OF THE PREFERRED EMBODIMENTS

[0006] An embodiment of a gaming machine according to the invention will be discussed in detail with reference to the accompanying drawings. Identical or equal elements are denoted by the same reference numeral and duplicate description will be omitted.

[0007] FIG. 1 is a perspective view to show a slot machine 1 as an example of a gaming machine according to the embodiment. The slot machine 1 has a cabinet 2 provided with a display 3 implemented as a liquid crystal display for digitally displaying a slot game. A coin insertion slot 4 for inputting game medium such as medals, tokens and coins (which will be hereinafter collectively called "coins") is provided below the display 3 at the cabinet 2. The slot machine 1 may be provided with a bill insertion slot in addition to the coin insertion slot 4, for allowing the player to play the slot game with a bill (paper money) or a paper token.

[0008] A control panel 5 is provided below the display 3. The control panel 5 is roughly similar to that provided for a known slot game and is provided with 14 buttons 6a to 6n as shown in FIG. 2.

[0009] As shown in FIG. 2, there are arranged in the upper left portion of the control panel 5 a collect button (COLLECT) 6a for paying out the coins gained in the game and a game rule button (GAME RULES) 6b for entering a command for executing a help function. The remaining 12 buttons are arranged at two stages roughly at the center of the control panel 5, the 12 buttons including: five bet buttons 6c to 6g for entering a bet number of coins (bet count); five line buttons 6h to 6l for entering a number of lines; a start feature button (START FEATURE) 6m for starting a feature game (for example, a free game); and a gamble button (GAMBLE) 6n for entering to start a transition to a double game at the termination time of the feature game.

[0010] Referring again to FIG. 1, a coin receiving tray 7 for the player to receive the coins paid out is provided in the lower portion of the cabinet 2. The slot machine 1 further includes: a sub-display 8 for displaying an image not directly involved in a game (for example, description of the game contents, and the image effect of the feature game), and a pair of speakers 9L and 9R.

[0011] FIG. 3 is a block diagram to show the internal configuration of the slot machine 1. As shown in FIG. 3, the slot machine 1 includes a plurality of components including a microcomputer 31.

[0012] The microcomputer 31 includes a main CPU (Central Processing Unit) 32 that serves as a controller, RAM (Random Access Memory) 33, and ROM (Read-Only Memory) 34.

[0013] The main CPU 32 operates in accordance with a program stored in the ROM 34 and inputs a signal from each sections (buttons) of the control panel 5 via an I/O port 39 and on the other hand, inputs/outputs a signal from/to other components for performing operation control of the whole slot machine 1. The RAM 33 stores data and programs used for the main CPU 32 to operate. For example, the RAM 33 temporarily retains the random number sampled by a sampling circuit 36 (described later) after a game starts. The ROM 34 stores programs executed by the main CPU 32 and permanent data.

[0014] The slot machine 1 is provided with a random number generator 35, a sampling circuit 36, a clock pulse generation circuit 37, and a frequency divider 38. The random number generator 35 operates in accordance with an instruction of the main CPU 32 and generates random numbers in a given range. The sampling circuit 36 extracts any random number from the random numbers generated by the random number generator 35 in accordance with an instruction of the main CPU 32 and inputs the extracted random number to the main CPU 32. The clock pulse generation circuit 37 generates a reference clock to operate the main CPU 32, and the frequency divider 38 divides the reference clock in a given period and inputs the result to the main CPU 32.

[0015] The slot machine 1 is further provided with a lamp drive circuit 59, a lamp 60, an LED drive circuit 61, an LED 62, a hopper drive circuit 63, a hopper 64, a payout completion signal circuit 65, and a coin detection section 66. The slot machine 1 is also provided with an image control circuit 71 for performing control processing of images displayed on the display 3 and the sub-display 8, and a sound control circuit 72 for controlling sound generated from the speakers 9L and 9R.

[0016] The lamp drive circuit 59 outputs a signal for lighting the lamp 60 to the lamp 60 and blinks the lamp 60 during the game. As the lamp 60 is blinked, a plurality of representation is produced in accordance with the game. The LED drive circuit 61 controls the blinking of the LED 62. The LED 62 displays information such as a number of credited coins and a number of gained coins. The hopper drive circuit 63 drives the hopper 64 under the control of the main CPU 32. The hopper 64 performs operation to pay out coins and causes coins to be paid out into the coin receiving tray 7.

[0017] The coin detection section 66 counts the number of coins paid out by the hopper 64 and transmits data indicating the counted number of coins (counted value) to the payout completion signal circuit 65. The payout completion signal circuit 65 receives the data of the number of coins from the coin detection section 66 and outputs a signal indicating a completion of the payout to the main CPU 32 when the number of coins paid out reaches a certain number of coins.

[0018] The image control circuit 71 controls image display on each of the display 3 and the sub-display 8 for displaying various images including symbol images, which will be described later, on the display 3 and the sub-display 8.

[0019] As shown in FIG. 4, the image control circuit 71 includes an image control CPU 71a, work RAM 71b, program ROM 71c, image ROM 71d, video RAM 71e, and a VDP (Video Display Processor) 71f. The image control CPU 71a determines the images to be displayed on the display 3 and the sub-display 8 in accordance with an image control program previously stored in the program ROM 71c based on parameters set in the microcomputer 31. The work RAM 71b serves as a temporary storage for the image control CPU 71a to execute the image control program.

[0020] The program ROM 71c stores the image control program and various selection tables. The image ROM 71d stores bitmap data that forms images. The bitmap data contains data of various symbol images (which will be hereinafter referred to as "symbol image group") in the embodiment. The video RAM 71e serves as a temporary storage for the VDP 71f to produce an image. The VDP 71f is provided with a control RAM 71g and produces images responsive to the display contents of the display 3 and the sub-display 8 determined by the image control CPU 71a and outputs each of the produced image to the display 3 and the sub-display 8.

[0021] FIG. 5 is a drawing to show an example of a game screen of the display 3. In the embodiment, a symbol display area section 81, a line number display section 82, and an upper display section 83 are displayed on the display 3.

[0022] The symbol display area section 81 is provided with five columns of display areas A to E each to display three symbols. Image processing is performed so that reel images with different kinds of symbols drawn are variably displayed so as to produce rotation display in the display areas A to E and that the symbols selected when the reel images stop are displayed in symbol display areas A1 to A3, B1 to B3, C1 to C3, D1 to D3, and E1 to E3.

[0023] The line number display section 82 displaying the line numbers indicating the pay lines is displayed on both sides of the symbol display area section 81. Of the line numbers displayed in the line number display section 82, the number corresponding to the pay line selected by the player is displayed as lit and the numbers not selected by the player are displayed as extinguished.

[0024] The upper display section 83 is formed above the symbol display area section 81. The upper display section 83 is provided with a number-of-credited-coins display section 83a, a number-of-BET-coins display section 83b, a text information display section 83c, a number-of-PAID-coins display section 83d, and a charge display section 83e. The number-of-credited-coins display section 83a displays the number of coins

credited at present, and the number-of-BET-coins display section 83b displays the number of coins bet on one game. The text information display section 83c displays text information indicating the current game state.

5 For example, when a feature game state is entered, the text information display section 83c displays text information indicating the state. The number-of-PAID-coins display section 83d displays the number of coins that can be gained in one game, and the charge display section 83e displays CREDIT.

10 **[0025]** FIG. 6 is a drawing to the symbols displayed in each of the symbol display areas A1 to E3. In the embodiment, each of the symbols is classified as one of a special symbol and a normal symbol. The symbols classified as the special symbol are: a bonus symbol T1; a wild symbol T2; a treasure chest symbol T3; a mask symbol T4; a chalice symbol T5; a map symbol T6; and a snake symbol T7. The symbols classified as the normal symbol are five symbols T8 to T12 each having a card mark different from each other.

15 **[0026]** The bonus symbol T1 classified as the special symbol is a symbol used as a trigger for entering a feature game (scatter symbol). For example, when a predetermined number of (for example, three) bonus symbols T1 or more are displayed in the display areas A to E, a transition is made to a feature game. When a predetermined number of bonus symbols T1 or more are displayed in the display areas A to E, a transition is made to a feature game and the display positions and the arrangement at the time may be any.

20 **[0027]** The wild symbol (specific symbol) T2 classified as the special symbol is a so-called almighty symbol, and is a symbol handled (deemed) as any of the five special symbols (the treasure chest symbol T3, the mask symbol T4, the chalice symbol T5, the map symbol T6, and the snake symbol T7) or any of the five normal symbols (symbols T8 to T12).

25 **[0028]** The normal symbols (card mark symbols) include an ace symbol (A) T8, a king symbol (K) T9, a queen symbol (Q) T10, a jack symbol (J) T11, and a numeric symbol (10) T12.

30 **[0029]** FIG. 7A and FIG. 7B are drawings to show examples of pay lines of the slot machine 1. For easy understanding, the pay lines are shown on two separated drawings. As shown in the drawings, nine pay lines are provided (defined) by way of example. When a predetermined symbol combination is arranged on any of the pay lines, an award responsive to the symbol combination is paid out to the player. Although not show, other eleven pay lines are provided and twenty pay lines are provided (defined) in total in the embodiment. Thus, multifaceted pay lines can be placed because the number of columns is increased to five in the embodiment.

35 **[0030]** The slot machine 1 provides a normal game state and a feature game state in the progress of a game. The main CPU 32 of the microcomputer 31 makes a winning determination as to whether or not a

feature game transition condition is satisfied. If the feature game transition condition is satisfied, a feature game is executed. The feature game transition condition is to display a predetermined number of bonus symbols T1 or more in the display areas A to E as described above. A coin payout rate in the feature game state is set higher than the coin payout rate in the normal game state. Thus, the player plays a normal game while expecting a transition to a feature game.

[0031] The winning determination is made depending on whether or not the same symbols are arranged on the pay lines of the 20 pay lines set in the symbol display areas A1 to A3, B1 to B3, C1 to C3, D1 to D3, and E1 to E3, specified by the player with the line buttons 6h to 6l. When the same symbols are arranged on the pay lines specified by the player, it is determined that the winning condition is satisfied, and a predetermined number of coins are paid out to the player. In the winning determination, the wild symbol T2 is deemed as an almighty symbol and is handled as an advantageous symbol for the award (the payout number of coins) in the ten kinds of symbols described above. That is, if only the ace symbol T8 and the wild symbol T2 are arranged in all symbol display areas on one play line, the same number of coins as the ace symbols T8 are arranged in all symbol display areas on one pay line are paid out to the player. In this case, the wild symbol T2 is handled as the ace symbol T8 on the pay line.

[0032] The arrangement of the symbols displayed in the display areas A to E will be discussed with reference to FIG. 8. As shown in FIG. 8, thirty symbols arranged in a predetermined order are scrolled circularly on the display in each of the display areas A to E; the player recognizes the display as if mechanical reels rotated for variably displaying the symbols. In the display areas A to E, the symbols may be scrolled in the same rotation period (cycle time) or may be scrolled in different rotation periods. Three symbols of a jack symbol T11, a queen symbol T10, and a king symbol T9 are placed continuously in this order in the symbol arrangement displayed in the display area C, of the display arrangements displayed in the five display areas A to E.

[0033] A control method of the slot machine 1 according to the embodiment will be discussed. FIG. 9 is a flowchart to show the game progress of the slot machine 1.

[0034] When starting main processing, the slot machine 1 first performs start acceptance processing in starting a game. More specifically, the main CPU 32 accesses the ROM 34 and transfers information concerning a basic screen, the information such as a frame displayed on the display 3, to the image control circuit 71, which then once stores the received information in the video RAM 71e and then displays the information on the display 3. Accordingly, the slot machine 1 enters a state that is ready to provide a slot game to the player. The subsequent processing is performed as the main CPU 32 executes the information concerning a slot game of the program stored in the ROM 34 and the RAM 33.

When the slot machine 1 is operated, a normal game is played as a slot game (step S100).

[0035] At step S100, the slot machine 1 waits for the player to bet. When the player inputs the number of coins bet on one game through the coin insertion slot 4 or presses any of the bet buttons 6c to 6g when credit is left, a game is started and the process proceeds to step S101.

[0036] In step S101, the main CPU 32 performs a lottery to determine symbols to be displayed in each of the symbol display areas A1-E3 from among the symbols T1-T12 in accordance with the random number sent from the sampling circuit 36 to the main CPU 32. For example, when random numbers are generated in the range of integers 0 to 400 and the random number 1 is acquired, the main CPU 32 determines to display a predetermined number of bonus symbols T1 in one of the symbol display areas A1-E3 to thereby satisfy a feature game transition condition to provide a feature game to the player. Such lottery based on the random number may be executed at any timing; for example, it may be executed when any of the bet buttons 6c to 6g is pressed or after variable display in the display areas A to E is produced.

[0037] When the symbols displayed in the display areas A to E are determined by performing the lottery, the main CPU 32 starts scrolling (variably displaying) the symbols displayed in the display areas A to E on the display 3 (step S102). The main CPU 32 controls the image control circuit 71 to perform image processing as if mechanical reels rotated.

[0038] Scrolling the symbols displayed in the display areas A to E is stopped in the order of the display areas A to E, whereby predetermined symbols shown in FIG. 5, for example, are displayed in the display areas A to E (step S103).

[0039] Next, the main CPU 32 determines whether or not a predetermined combination (effective display sequence: T11, T10, and T9, in the embodiment) of the symbols is determined in step S101 to be displayed in a predetermined display area (display area C having display sequence of C1, C2, and C3, in the embodiment) (step S104). The CPU 32 proceeds the process to step S105 if the predetermined combination is determined to be displayed in the predetermined display area (YES in step S104), and proceed the process to step S106 if not (NO in step S104).

[0040] When the display sequence of the symbols arranged in the symbol display areas C1, C2, and C3 of the display area C matches the effective display sequence of the arrangement of a jack symbol T11, a queen symbol T10, and a king symbol T9 as in FIGS. 10 and 13, the main CPU 32 replaces all of the three symbols T9, T10, and T11 to wild symbols (specific symbols) T2 (step S105). Accordingly, the display sequence of the symbol display areas C1, C2, and C3 of the display area C becomes the display sequence of the three continuous wild symbols T2 as shown in FIGS. 11 and

14. The main CPU 32 proceeds the process to step S106 after the process of step S105.

[0041] In step S106, the main CPU 32 performs a winning determination. When the same symbols are arranged on the pay line specified by the player, the main CPU 32 determines that the winning condition is satisfied, and pays out a predetermined number of coins to the player (step S107). That is, when the symbol arrangement in the display areas A to E is as shown in FIG. 10 and 13, if attention is focused only on the symbol arrangement on the pay line of line number 1 (horizontal pay line at the middle stage; see FIG. 7A), the symbol arrangement is a combination of four ace symbols T8 and one queen symbol T10, namely, a combination according to which no coins are paid out. In the symbol arrangement in FIG. 10, however, the display sequence of the symbols arranged in the display area C is the effective display sequence (display sequence in which the symbols are arranged in the order of symbol T11, symbol T10, symbol T9 from the top to the bottom) and therefore the effective display sequence is replaced with the sequence in which three wild symbols T2 are arranged as in FIG. 11 and 14; in fact, it is determined that five ace symbols T8 are arranged on the pay line of line number 1, and a predetermined number of coins are paid out to the player.

[0042] When the display sequence of the symbols arranged in the symbol display areas C1, C2, and C3 of the display area C shifts even one stage from the effective display sequence of the arrangement of the jack symbol T11, the queen symbol T10, and the king symbol T9 as shown in FIG. 12, the three symbols T9, T10, and T11 are not replaced to wild symbols (specific symbols) T2 in step S105, and the winning determination is made with the symbols unreplaced.

[0043] Thus, when scrolling the symbols in the display areas A to E stops, if the predetermined effective display sequence (namely, display sequence in which the symbols are arranged in the order of symbol T11, symbol T10, symbol T9 from the top to the bottom) is displayed in the display area C, the symbol T9, the symbol T10, and the symbol T11 are replaced to the wild symbols T2 of almighty symbols (see FIG. 11 and 14) and the winning determination is made actually as the wild symbols T2, so that the arrangement/combination of the symbols on the pay line specified by the player easily becomes a symbol arrangement/combination advantageous for award. Thus, when symbols are thus replaced to the wild symbols T2, the player can expect a high award. Therefore, even after scrolling the symbols in the display areas A to E stops, a sense of expectation of the player can be maintained significantly, enabling the player to continue playing a game with enjoyment without being bored. That is, the slot machine 1 provides improved amusement to the player as compared with conventional slot machines.

[0044] Since all of the symbols displayed in the symbol display areas C1, C2, and C3 of the display area C

are the wild symbols T2, every pay line contains the wild symbol T2. Thus, the wild symbol T2 is always involved in the winning determination on any pay line, so that improvement in the payout rate is intended significantly. The display sequence of the symbols T9, T10, and T11 arranged in one display area C of the five display areas A to E is thus replaced to the display sequence of the wild symbols T2, whereby the wild symbol T2 is placed on each pay line at a high probability, so that the player can expect a large number of coins to be paid out.

Next, in step S108, the main CPU 32 determines that whether or not the feature game transition condition is satisfied.

[0045] That is, if it is determined at step S108 that the feature game transition condition is satisfied, three or more bonus symbols T1 are displayed in the display areas A to E and a transition is made from the normal game state to the feature game state (S109). In the feature game of the embodiment, in which a so-called free game is employed as the feature game, symbol scrolling is repeated without inputting any coin or pressing any of the bet buttons 6c to 6g. That is, during the feature game, the player can receive payout of coins without consuming any coin or any credited coin and thus the feature game state is a very advantageous state for the player. After the feature game, the process proceeds to step S100.

On the other hand, if it is determined at step S108 that the no or one or two bonus symbols T1 are displayed in the display areas A to E, the transition to the feature game transition condition is not made, and the process proceeds to step S100.

In the embodiment described above, the main CPU 32 serves as: lottery means for performing a lottery to determine symbols to be displayed in each of the symbol display areas from among a plurality of symbols; a controller that controls the display to display the symbols determined by the lottery means to be stopped in each of the symbol display areas after variably displaying the plurality of symbols in each of the symbol display areas; and determination means for performing a winning determination in accordance with a combination of the symbols displayed in the symbol display areas.

[0046] The configuration of the slot machine 1 is not limited to the specific embodiment described above and various modifications can be made.

In the above described embodiment, the display sequence of the jack symbol T11, the queen symbol T10, and the king symbol T9 are replaced to the wild symbols T2 when the three symbols T11, T10, T9 are displayed in the display area C. However, the slot machine 1 may be configured that the display sequence of the jack symbol T11, the queen symbol T10, and the king symbol T9 are replaced to the wild symbols T2 when the three symbols T11, T10, T9 are displayed in any of the display areas other than the display area C, such as the display areas A, B, D, or E.

The display sequence of the symbols to be re-

placed to the wild symbols T2 is not limited to the display sequence of the jack symbol T11, the queen symbol T10, and the king symbol T9, and any predetermined sequence of the various symbols T1 to T12 as shown in FIG. 6 can be used.

[0047] In the embodiment, the symbols T11, T10, T9 are replaced to the wild symbols T2 when a predetermined symbol display sequence is arranged in a single display area, which is the display area C. However, the slot machine may be configured that when a predetermined symbol display sequence is arranged continuously in a horizontal direction or a slanting direction so as to extend across a plurality of display areas, the arranged symbols are replaced to the wild symbols T2. The specific symbol of to be displayed after the replacement is not limited to the wild symbol T2 and may be any symbols such as the bonus symbol T1 for enabling the player to expect a large award finally.

In the embodiment, each of the display areas A to E is configured in a vertical direction as shown in Fig. 5. However, each of the display areas may be configured in a horizontal direction, such that the display area A is provided with the symbol display areas A1, B1, C1, D1, and E1, while the display area B is provided with the symbol display areas A2, B2, C2, D2, and E2, and the display area C is provided with the symbol display areas A3, B3, C3, D3, and E3.

In the embodiment, each of the reel images is provided for each of the display areas A to E, respectively, and the image processing is performed so that the reel images are displayed to rotate in the vertical direction to variably display the symbols in the symbol display areas. However, the image processing may be performed so that the reel images are displayed to rotate in the horizontal direction.

In the embodiment, a predetermined effective display sequence (sequence of the symbols T11, T10, T9) is replaced to the specific symbol display sequence (sequence of the wild symbols T2) in the normal game state. However, the replacement from the effective display sequence to the specific symbol display sequence may be caused to occur only in the feature game state or may be caused to occur both in the normal game state and in the feature game state.

In the embodiment, the winning determination (step S106) is performed after the stopping the scrolling symbols (step S103). However, a timing to perform the winning determination is not limited to the timing described in the embodiment, and the winning determination may be performed at an arbitrary timing. For example, the slot machine 1 may be configured to perform the winning determination after performing the lottery to determine symbols to be displayed in each of the symbol display areas A1-E3 in step S101.

In the embodiment, the winning determination is performed only once in one normal game. However, the slot machine 1 may be configured to perform the winning determination for a plurality of times. For example, the

slot machine 1 may be configured to perform the winning determination when the symbols determined by the lottery performed in step S101 are stopped in the symbol display areas (e.g., between step S103 and step S104), and perform the winning determination again after the predetermined combination of the symbols (symbols T11, T10, and T9) are replaced into the different symbol (symbol T2).

In the embodiment, the symbol (the different symbol) to be replaced when the predetermined combination of the symbols (symbols T11, T10, and T9) are stopped in the predetermined symbol display areas (C1-C3) is predefined as the wild symbol T2 that is deemed in the winning determination as any of the plurality of symbols T1, and T3-T12. However, the different symbol that is displayed after the replacement is not limited to the wild symbol T2 and may be any one of the plurality of symbols T1-T12. Fig. 15 shows one example that the predetermined combination of symbols is replaced into the mask symbol T4.

The different symbol to be replaced may be determined by performing a lottery from among the plurality of symbols T1-T12. For example, the slot machine 1 may be configured that the main CPU 32 performs a lottery to determine the different symbol from among the plurality of symbols in advance to step S105, and the main CPU 32 controls the display 3 to replace the predetermined combination of the symbols into the different symbol determined by the lottery.

In the embodiment, the replacement of the symbols in step 105 is performed only once. However, the slot machine 1 may be configured to perform the replacement for a plurality of times. For example, the slot machine 1 may be configured that the main CPU 32 performs a lottery to determine a plurality of the different symbols to be displayed in the replacement from among the plurality of symbols, and the main CPU 32 controls the display 3 to replace the different symbols sequentially after replacing the predetermined combination of the symbols into one of the different symbols. In this case, the main CPU 32 may perform the winning determination each time the replacement is made.

It is preferable to configure the main CPU 32 to control the display 3 to display the different symbol being applied with a special image effect. The special image effect maybe any one of or combination of arbitrary image effects such as scaling, deforming, flashing, and the like. Fig. 16 shows one example that the replaced different symbol (symbol T2) is enlarged as one symbol.

As described with reference to the embodiment, there is provided a gaming machine including a display having a plurality of symbol display areas where a plurality of continuous symbols are variably displayed; and a controller for executing a predetermined program and controlling the display contents of the display, characterized in that when the display sequence of the symbols arranged in at least one of the symbol display areas is a predetermined effective display sequence, the con-

troller replaces the display sequence of the symbols to a specific symbol display sequence advantageous for an award in accordance with the program.

In the gaming machine, when the display sequence of the symbols in at least one of the symbol display areas is the predetermined effective display sequence, the display sequence of the symbols is replaced to the specific symbol display sequence. As the display sequence of the symbols is replaced, the award becomes more advantageous. That is, if the display sequence of the symbols is replaced to the specific symbol display sequence, the player of the slot machine 1 can expect a larger payout than that before the symbol sequence is replaced and thus can continue playing a game with enjoyment without being bored.

When the display sequence of the symbols arranged in one of the symbol display areas is the predetermined effective display sequence, preferably the controller replaces the display sequence of the symbols to the specific symbol display sequence. In this case, the specific symbols are placed on the activated pay line used for award determination at a high probability, so that the player can expect a larger number of coins to be paid out.

Accordingly, the gaming machine provides improved amusement as compared with conventional gaming machines.

The foregoing description of the embodiment of the invention has been presented for purposes of illustration and description. It is not intended to be exhaustive or to limit the invention to the precise form disclosed, and modifications and variations are possible in light of the above teachings or may be acquired from practice of the invention. The embodiment was chosen and described in order to explain the principles of the invention and its practical application to enable those skilled in the art to utilize the invention in various embodiments and with various modifications as are suited to the particular use contemplated. It is intended that the scope of the invention be defined by the claims appended hereto, and their equivalents.

Claims

1. A gaming machine comprising:

a display that displays a game screen having a plurality of display areas provided with a plurality of symbol display areas;
 lottery means for performing a lottery to determine symbols to be displayed in each of the symbol display areas from among a plurality of symbols; and
 a controller that controls the display to display the symbols determined by the lottery means to be stopped in each of the symbol display areas after variably displaying the plurality of

symbols in each of the symbol display areas,

wherein when a predetermined combination of the symbols is determined by the lottery means to be displayed in at least one of the display areas, the controller controls the display to replace the predetermined combination of the symbols into a different symbol different from the symbols in the predetermined combination after displaying the symbols determined by the lottery means to be stopped in each of the symbol display areas.

2. The gaming machine according to claim 1 further comprising determination means for performing a winning determination in accordance with a combination of the symbols displayed in the symbol display areas.

3. The gaming machine according to claim 2, wherein at least one pay line is defined in the symbol display areas,

wherein the determination means performs the winning determination in accordance with a combination of the symbols stopped on the pay line.

4. The gaming machine according to claim 2, wherein the determination means performs the winning determination when the symbols determined by the lottery means are stopped in the symbol display areas, and

wherein the determination means performs the winning determination after the predetermined combination of the symbols are replaced into the different symbol.

5. The gaming machine according to claim 1, wherein the lottery means performs a lottery to determine the different symbol from among the plurality of symbols, and

wherein the controller controls the display to replace the predetermined combination of the symbols into the different symbol determined by the lottery means.

6. The gaming machine according to claim 1, wherein the lottery means performs a lottery to determine a plurality of the different symbols from among the plurality of symbols, and

wherein the controller controls the display to replace the different symbols sequentially after replacing the predetermined combination of the symbols into one of the different symbols.

7. The gaming machine according to claim 6 further comprising determination means for performing a winning determination in accordance with a combination of the symbols displayed in the symbol display areas,

wherein the determination means performs the winning determination each time the controller controls the display to replace the different symbols.

8. The gaming machine according to claim 2, wherein each of the symbols is classified as one of a special symbol and a normal symbol, and
 wherein the gaming machine further comprises payout means for performing larger payout in a case where a win based on the special symbol is determined by the determination means than in a case where a win based on the normal symbol is determined by the determination means. 5
 10
9. The gaming machine according to claim 8, wherein when the predetermined combination of the symbols is determined by the lottery means to be displayed in the predetermined symbol display areas, the controller controls the display to replace the predetermined combination of the symbols into the different symbol that is classified as the special symbol after displaying the symbols determined by the lottery means to be stopped in each of the symbol display areas. 15
 20
 25
10. The gaming machine according to claim 2, wherein the different symbol is a wild symbol that is deemed by the determination means as at least one of the plurality of symbols. 30
11. The gaming machine according to claim 1, wherein the display is provided with at least one reel that rotates and has a periphery on which the plurality of symbols are arranged, and
 wherein the display displays the plurality of symbols arranged on the periphery of the reel in each of the symbol display areas. 35
12. The gaming machine according to claim 11, wherein the reel is a video reel that is displayed on the display as a video image. 40
13. The gaming machine according to claim 11, wherein the reel is a mechanical reel that is rotatably provided behind the display. 45
14. The gaming machine according to claim 1, wherein the controller controls the display to display the different symbol being applied with a special image effect. 50
15. The gaming machine according to claim 14, wherein the controller controls the display to display the different symbol to be enlarged as one symbol. 55

FIG. 1

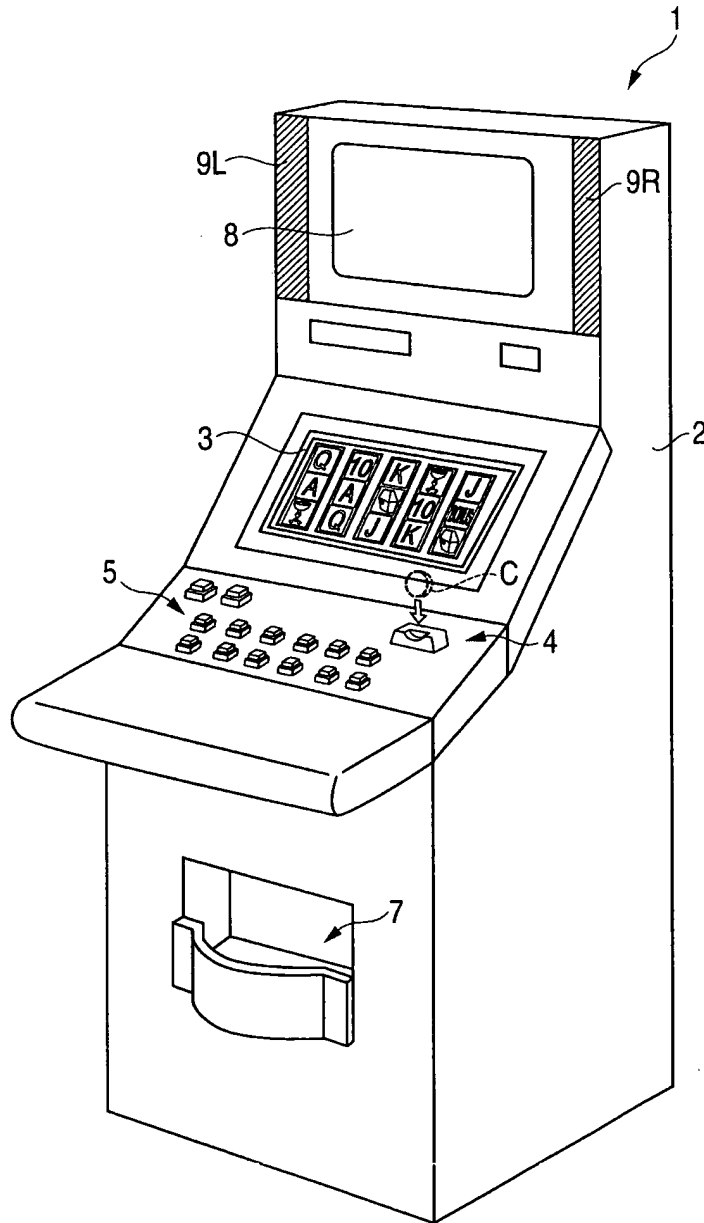

FIG. 2

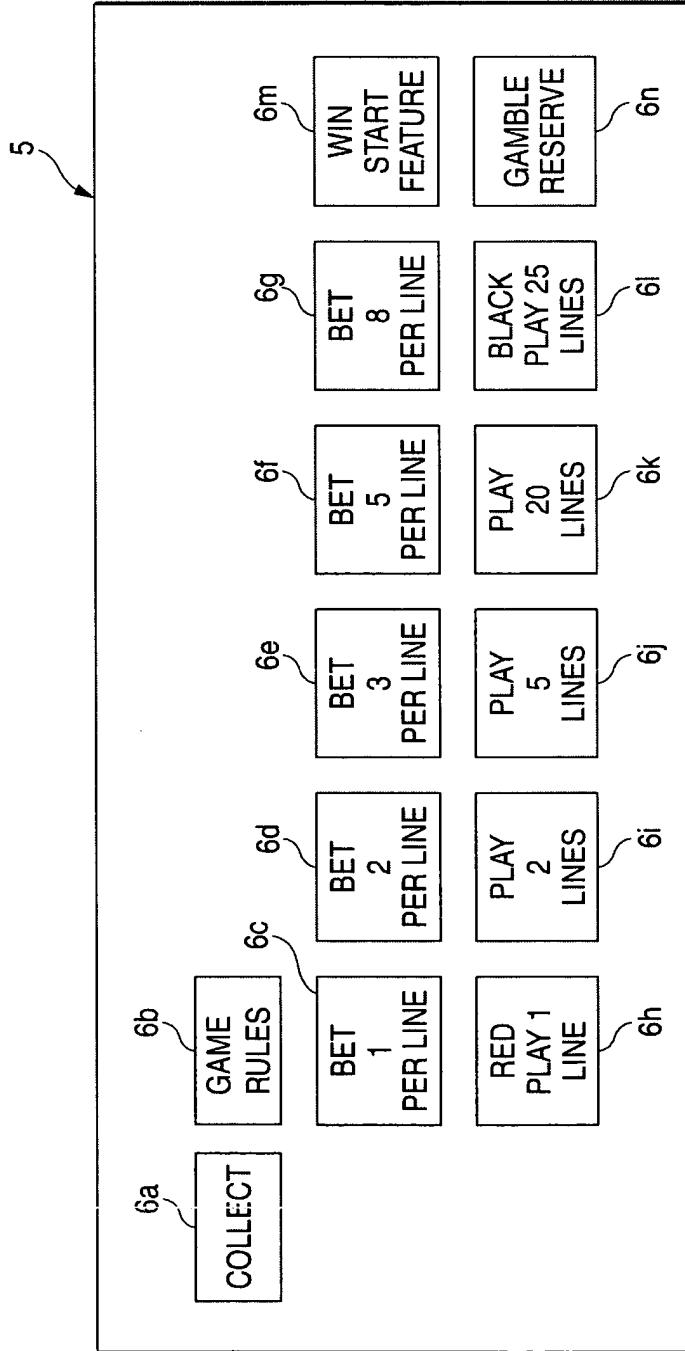

FIG. 3

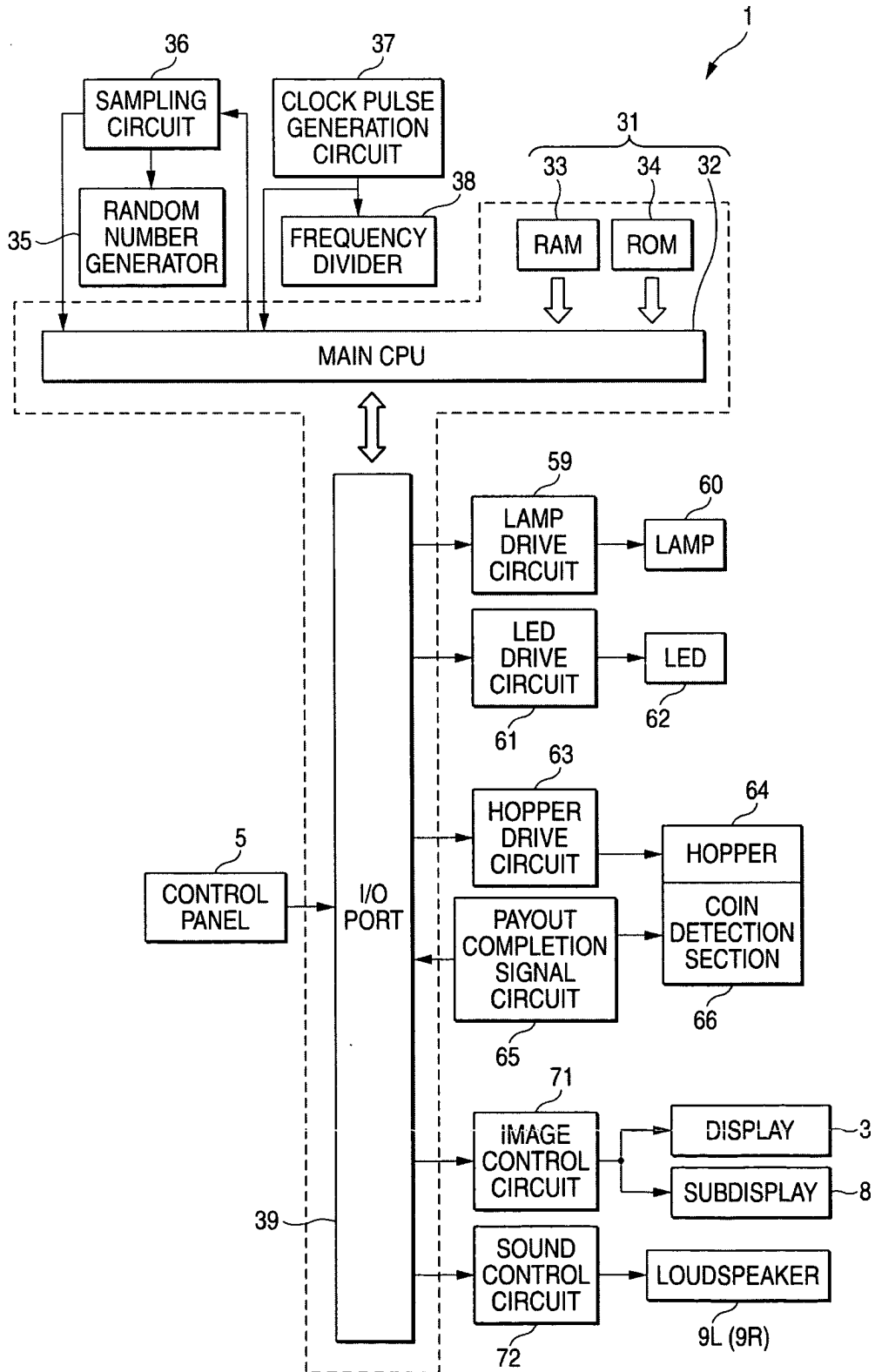

FIG. 4

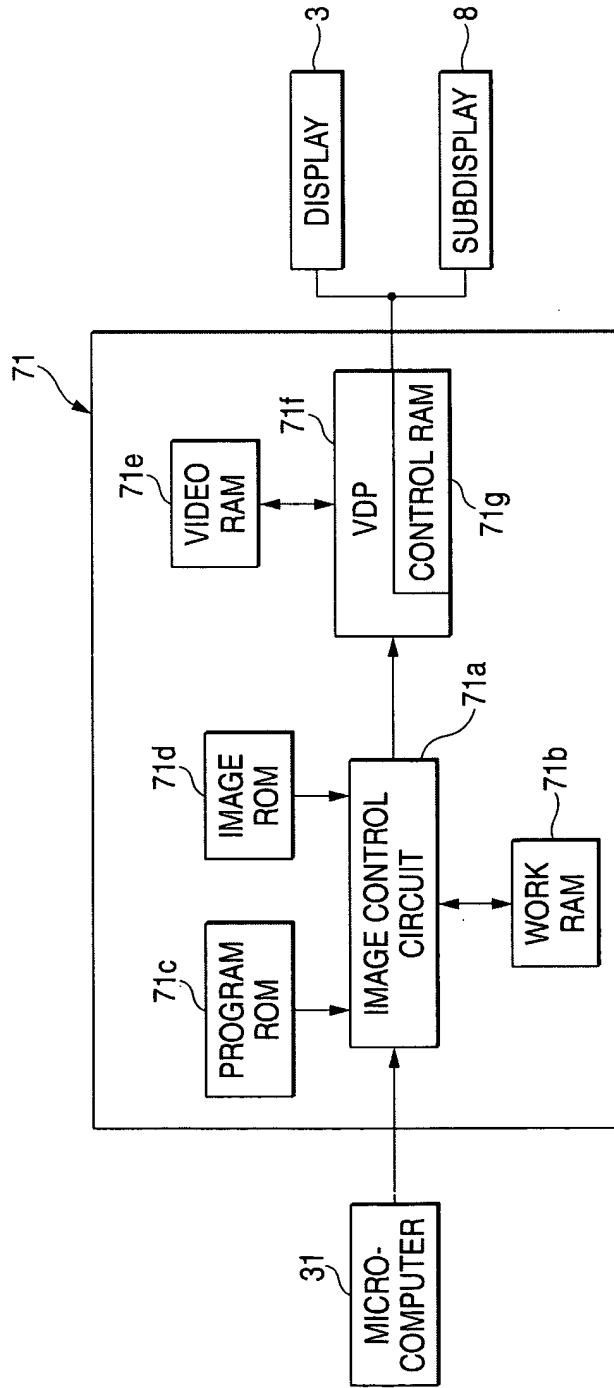

FIG. 5

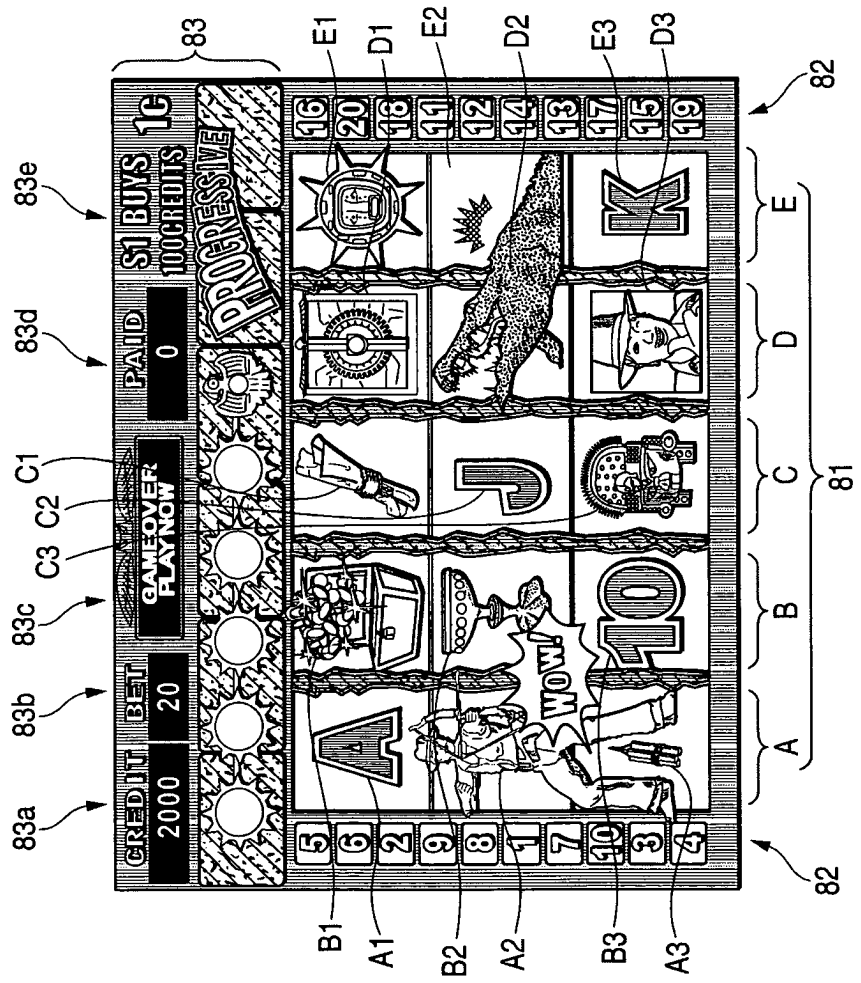

FIG. 6

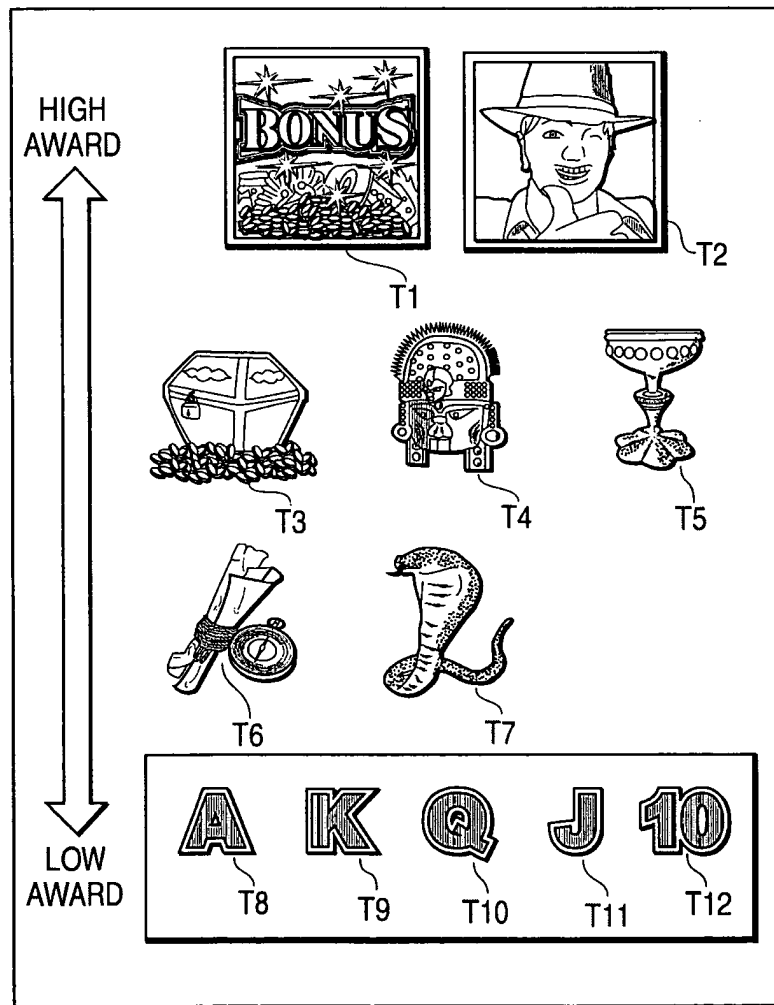

FIG. 7A

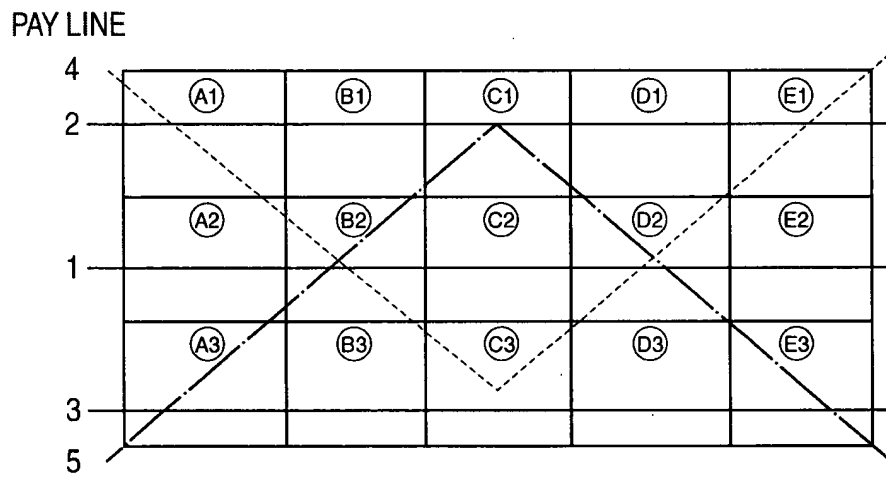

FIG. 7B

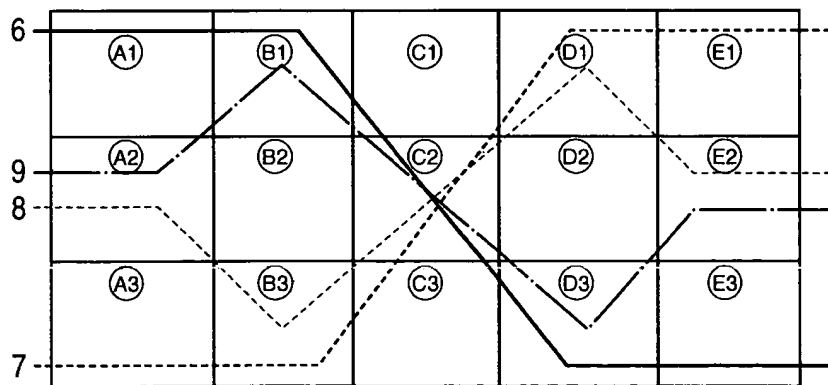

FIG. 8

A	B	C	D	E
T12	T6	T9	T11	T12
T11	T9	T10	T12	T9
T2	T2	T2	T2	T2
T12	T6	T8	T11	T12
T11	T10	T11	T10	T9
T7	T12	T2	T2	T4
T9	T4	T5	T9	T7
T8	T8	T9	T10	T5
T10	T12	T12	T1	T10
T4	T7	T1	T9	T1
T5	T6	T9	T10	T11
T11	T9	T11	T7	T7
T3	T1	T8	T5	T10
T7	T8	T11	T10	T8
T10	T12	T10	T3	T4
T9	T6	T9	T8	T12
T6	T3	T7	T9	T6
T12	T12	T9	T6	T11
T11	T6	T10	T4	T8
T4	T7	T3	T10	T12
T10	T11	T11	T8	T11
T12	T5	T10	T5	T6
T1	T7	T6	T9	T9
T7	T6	T11	T3	T5
T12	T12	T9	T7	T8
T8	T8	T8	T10	T11
T11	T7	T12	T11	T7
T7	T10	T11	T6	T5
T9	T6	T5	T8	T10
T4	T8	T10	T11	T6

FIG. 9

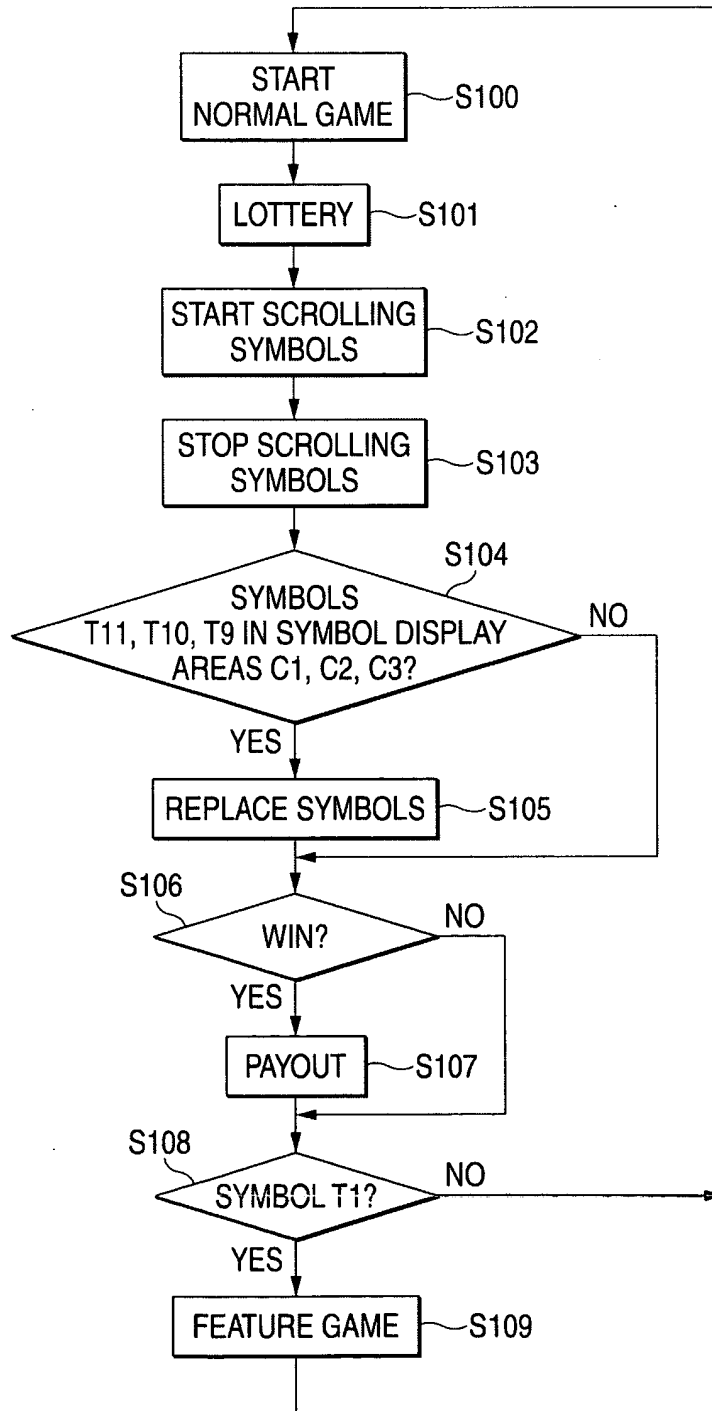

FIG. 10

(A1)	T9	(B1)	T12	(C1)	T11	(D1)	T6	(E1)	T10
(A2)	T8	(B2)	T8	(C2)	T10	(D2)	T8	(E2)	T8
(A3)	T10	(B3)	T7	(C3)	T9	(D3)	T11	(E3)	T4

FIG. 11

(A1)	T9	(B1)	T12	(C1)	T2	(D1)	T6	(E1)	T10
(A2)	T8	(B2)	T8	(C2)	T2	(D2)	T8	(E2)	T8
(A3)	T10	(B3)	T7	(C3)	T2	(D3)	T11	(E3)	T4

1

FIG. 12

(A1)	T9	(B1)	T12	(C1)	T10	(D1)	T6	(E1)	T10
(A2)	T8	(B2)	T8	(C2)	T9	(D2)	T8	(E2)	T8
(A3)	T10	(B3)	T7	(C3)	T7	(D3)	T11	(E3)	T4

FIG. 13

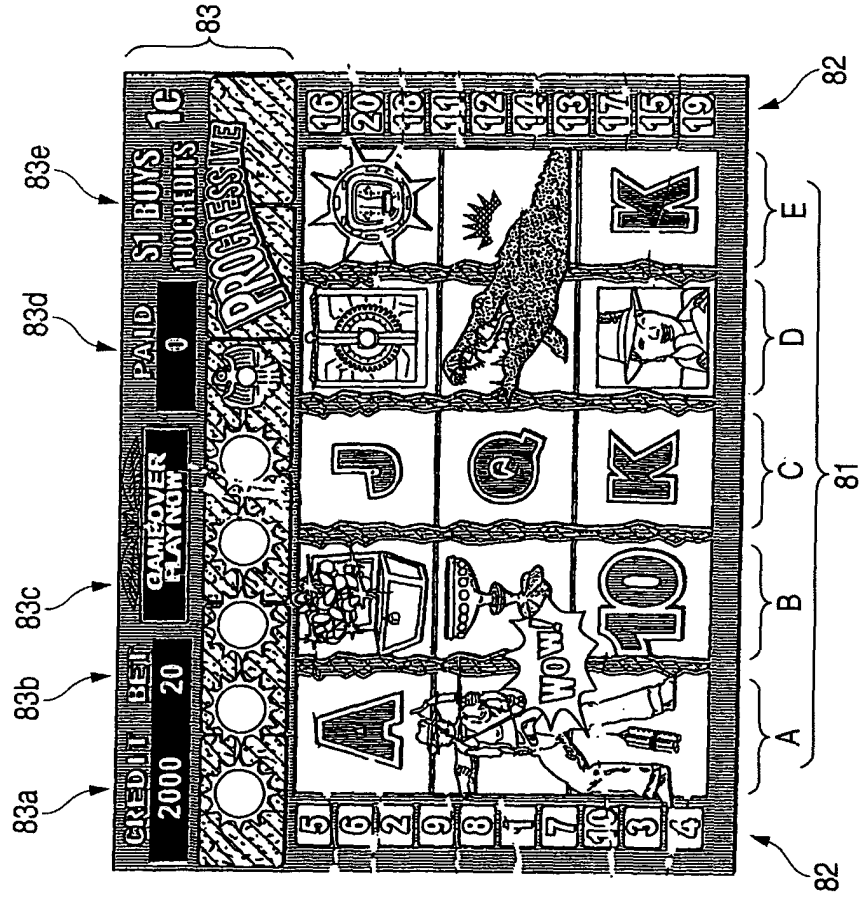

FIG. 14

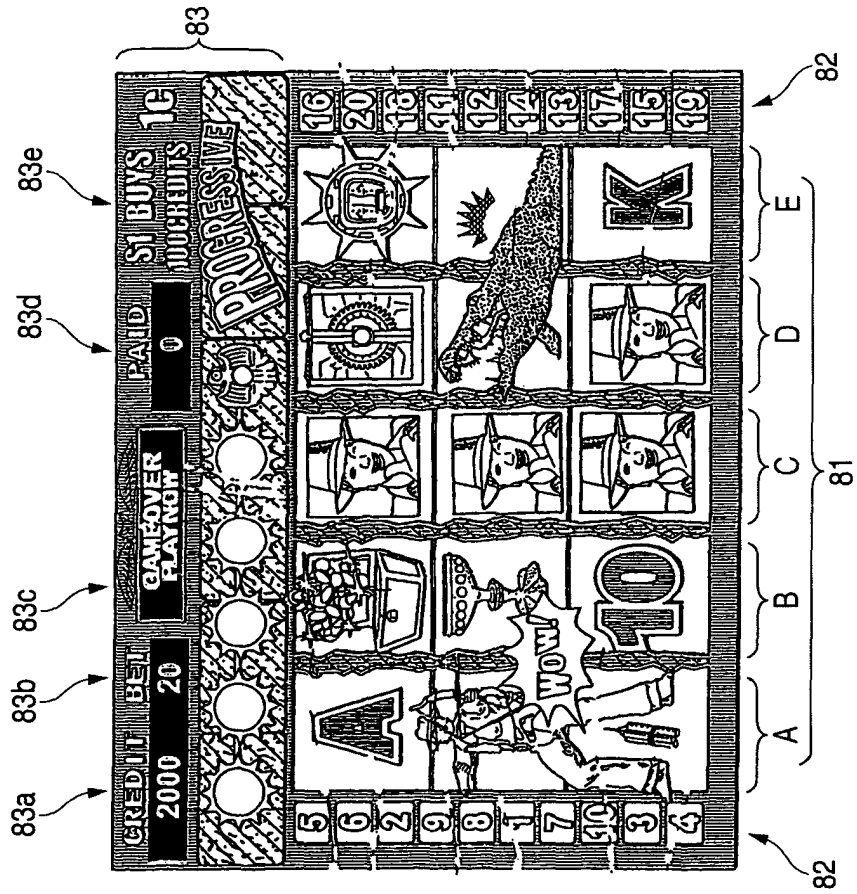

FIG. 15

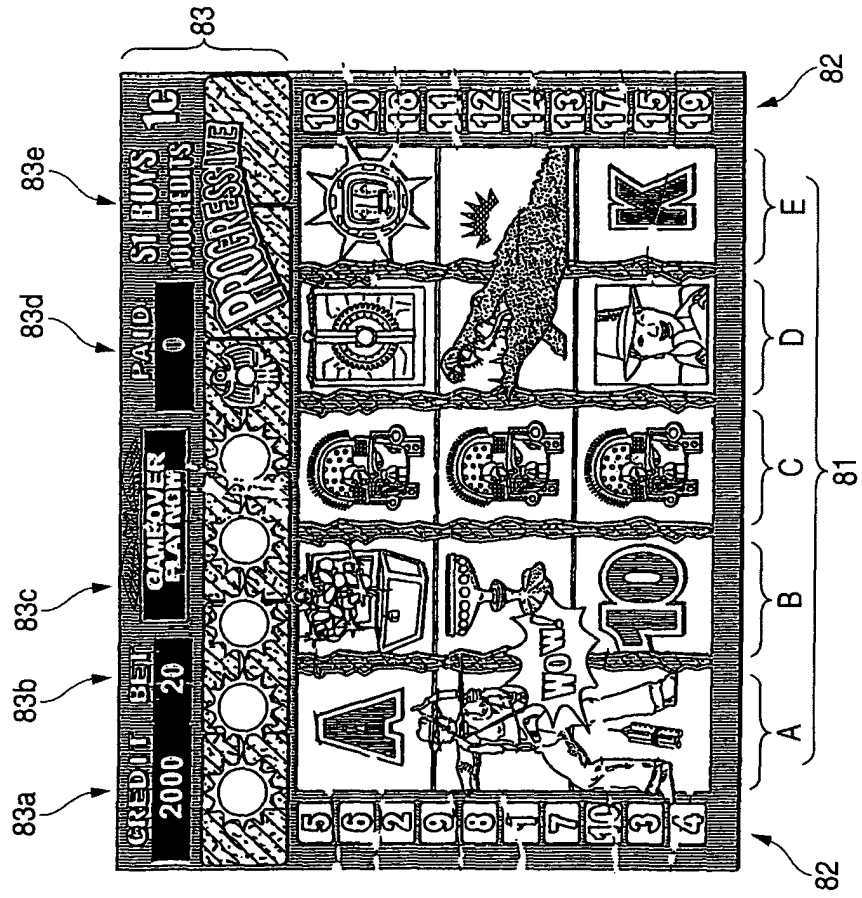

FIG. 16

