



Europäisches Patentamt
European Patent Office
Office européen des brevets



Publication number: **0 575 753 A2**

EUROPEAN PATENT APPLICATION

Application number: **93108236.6**

Int. Cl.⁵: **G07C 9/00, G07C 1/20**

Date of filing: **21.05.93**

Priority: **16.06.92 US 899558**

Date of publication of application:
29.12.93 Bulletin 93/52

Designated Contracting States:
DE ES FR GB IT SE

Applicant: **MOTOROLA, INC.**
1303 East Algonquin Road
Schaumburg, IL 60196(US)

Inventor: **Anderson, Neal R.**
604 S. El Dorado Road
Mesa, Arizona 85202(US)
Inventor: **Malone, Hugh R.**

5101 E. Mulberry Street
Phoenix, Arizona 85018(US)
Inventor: **Bjornholt, John E.**
1904 E. Hackamore
Mesa, Arizona 85203(US)
Inventor: **Boyle, Philip J.**
1527 E. Knox Road
Tempe, Arizona 85284(US)

Representative: **Hudson, Peter David et al**
MOTOROLA
European Intellectual Property Operations
Jays Close
Viabes Industrial Estate
Basingstoke, Hampshire RG22 4PD (GB)

Electronic monitoring system.

An electronic monitoring system (10) for monitoring a large number of inmates confined in an institution is described. Each inmate wears a transmitter (14) which broadcasts an RF signal (18) at random times within a predetermined interval. Reference transmitters (16) positioned at known locations provide calibration so that local transmission anomalies and system variations are accounted for. The transmitted signals (18) contain a common code and also codes unique to each individual transmitter (12). Multiple receivers (22) positioned at known locations receive the transmitted signals (18). The relative times of arrival of the inmate and reference transmitter signals (18) at the multiple receivers (22) are used to determine the location of the inmate transmitters (14). The inmate transmitters (14) may also broadcast an intermittent acoustic signal (15) which is sensed by detectors (17) on the reference transmitters (16), which then transmit a tagged RF signal (18) indicating receipt of the acoustic signal (15). The system (10) provides updated inmate headcount and location about every second.

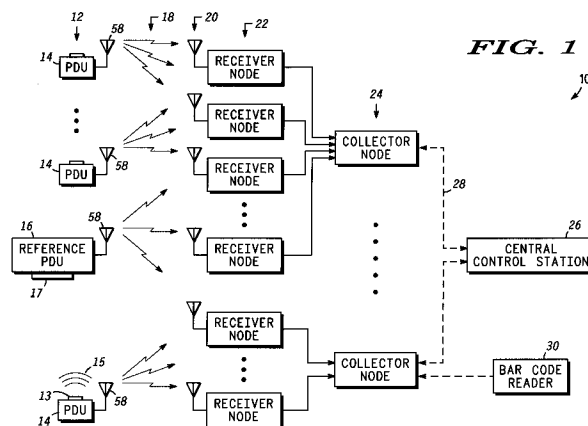

EP 0 575 753 A2

Field of the Invention

This invention concerns an apparatus and method for monitoring a predetermined population in a predetermined location.

5

Background of the Invention

There is an ongoing need to be able to track the whereabouts and identity of animals, objects, prisoners, patients, service and support personnel and/or guards or keepers in various institutions such as prisons, hospitals, farms, warehouses and other locations having controlled populations. For convenience of expression, the terms "inmate" and "inmates" are used herein to represent exemplary members of a population of objects or persons or animals being monitored in a predetermined location.

The inmates being monitored may be involuntarily confined, as for example, in a prison or warehouse or farm, or may be voluntarily confined as for example prison guards or support personnel or patients or medical staff in a hospital, or inmates associated with some other type of institution. For convenience of description, the example of a prison is used in the description that follows, but those of skill in the art will understand that the problems and solutions described in connection therewith apply to many other inmate populations and institutions as well.

In many such institutions real time inventory accounting, location tracking and status monitoring of inmates are often needed. In general it is important to know not only that the total actual inmate count equals the expected number, but also to know the whereabouts of specific inmates, i.e., is each inmate in a proper location. In other situations it is also important to know additional information about inmate status. For example, (1) where the inmate is a person or animal, are there life signs, (2) where the inmate is a guard, is the guard in a normal condition, e.g., positive vital signs, no threat alarm, posture normal, etc., and/or (3) where the inmates are uncooperative and/or confined involuntarily, has there been any tampering with the monitoring system or any attempt to evade monitoring.

In the past, monitoring typically been done by manual methods, e.g., by eye and ear using paper records. For example, inmates are counted and identified and their location determined by visual inspection and the results recorded on paper or even in a computer by manual data entry. The results are then compared with the predetermined paper or computer records to ensure that the correct number of inmates is present, that each inmate is at a permitted or preassigned location and that no emergency conditions exist.

Various attempts have been made in the past to supplement the classic "eye-ball and paper record" monitoring methods with electronic systems. Electronic monitoring systems are described, for example, in U. S. Patent Nos. 3,439,320 to Ward, 3,478,344 to Schwitzgebel, 4,347,501 to Akerberg, 4,598,272 to Cox, 4,598,275 to Ross, 4,785,291 to Hawthorne, 4,814,751 to Hawkins, and 4,885,571, 4,918,432 and 4,952,913 to Pauley. While these prior art approaches are suitable under certain circumstances, for example as "home arrest systems", they have a number of limitations well known in the art and none are entirely suitable, especially for institutional settings where a large number of inmates (e.g., 10-1000) must be monitored in a predetermined confinement region, e.g., a prison, cell-block, hospital, ward, warehouse, farmyard, etc. Accordingly, there is an ongoing need for improved electronic monitoring systems which overcome the deficiencies in the prior art and which are suited to the requirements of institutions containing large numbers of inmates confined within a predetermined location.

SUMMARY OF THE INVENTION

The foregoing and other problems of the prior art are overcome by the improved electronic monitoring apparatus and method of the present invention.

An electronic system for monitoring inmates within a predetermined inmate location region comprises one or more individual inmate transmitters, each coupled to an inmate being monitored and transmitting at random, within a first prescribed time range, signals containing codes identifying individual inmate transmitters, one or more reference transmitters fixed at known positions within the location region and transmitting at random, within a second prescribed time range, signals containing codes identifying individual reference transmitters, and a receiver having multiple antennas placed at predetermined locations within the region for receiving signals from the inmate and reference transmitters and determining locations of the inmate transmitters in part based on signals received from the reference transmitters.

In a preferred embodiment, the transmitters comprise spread-spectrum modulators for providing spread spectrum signals containing a predetermined spread spectrum code and the receivers comprise a correlator

for preferentially detecting the presence of the predetermined spread spectrum code to provide an output pulse for precise determination of times of arrival of the spread spectrum signals from the transmitters. In the preferred embodiment, the transmitters contain electrical circuits for generating random transmit times within the prescribed transmit time ranges.

5 In a further embodiment, the signals provided by the transmitters are rf signals and the inmate transmitters further comprise acoustic radiator means for providing a sonic tone burst substantially coincident with transmission of the rf signal from the same inmate transmitter, and wherein the reference transmitters contain acoustic detectors for detecting the sonic tone burst and thereafter launching an rf signal containing a code indicating that a sonic signal has been received..

10 The preferred embodiment further comprises in the transmitter, an alarm detector for determining when an alarm condition exists at the transmitter and a means for adjusting the nominal transmit time interval to make such interval shorter, at least temporarily, when such alarm condition exists.

A method for monitoring inmates within a predetermined inmate location region comprises transmitting first signals from transmitters coupled to inmates having variable positions relative to the location region, and transmitting second signals from reference transmitters having known positions relative to the location region, wherein signals from all transmitters contain a known common code and a further code uniquely identifying each individual transmitter, receiving signals at multiple receivers having further known positions relative to the location region, coupling the received signals through correlators for separating the first and second signals from other signals arriving at the multiple receiver locations, determining relative times of arrival of the first and second signals at the multiple receiver positions, and calculating the location of the inmate transmitters based at least in part on the relative times of arrivals of the first and second signals at the multiple receiver positions.

In a preferred embodiment, the method comprises, prior to transmitting, forming the first and second signals by modulating an rf carrier with a coded modulation signal, wherein the coded modulation signal comprises a sequence of M data bits, wherein each transmitter has a unique combination of such M data bits, and wherein data bits representing a logical "1" or "0" comprise $(2^n - 1)$ sub-bits, wherein each sub-bit is composed of a predetermined number of cycles of a predetermined frequency and a sequence of relative phases of adjacent sub-bits making a data bit forms the common code. In the preferred embodiment, a logical "1" or "0" is represented by the common code sequence of $(2^n - 1)$ sub-bits and a logical "0" or "1" is represented by a different sequence of $(2^n - 1)$ sub-bits, as for example, a CW signal or no signal or another code.

A further embodiment of the method comprises transmitting an acoustic signal from an inmate transmitter to an acoustic detector coupled to a reference transmitter, whereupon that reference transmitter transmits an rf signal comprising an indication that an acoustic signal has been received by that reference transmitter.

In the preferred embodiment, the steps of transmitting the first and second signals comprise transmitting the first and second signals from each transmitter at individual randomly chosen times, preferably lying within at least one predetermined time interval.

In a further implementation, the method further comprises transmitting as a part of the first signal from a particular inmate transmitter, a further code indicating that an alarm condition exists at that inmate transmitter, and when an alarm condition exists at an inmate transmitter, the predetermined time range is made smaller.

As used herein, the words "sonic" and "acoustic" are intended to refer to sound waves of any frequency whether audible or not.

45

BRIEF DESCRIPTION OF THE DRAWINGS

FIG. 1 is a simplified schematic block diagram illustrating a preferred embodiment of the present invention;

50 FIG. 2 is a simplified schematic block diagram illustrating a typical inmate transmitter unit according to the present invention;

FIG. 3 is a simplified schematic block diagram illustrating a typical reference transmitter unit according to the present invention;

55 FIG. 4 is a simplified schematic block diagram illustrating a typical receiver unit according to the present invention;

FIG. 5 is a simplified schematic block diagram illustrating a typical collector node unit according to the present invention;

FIG. 6 is a simplified schematic block diagram illustrating a typical central control station according to the present invention;

FIG. 7 is a simplified timing and data structure diagram illustrating a typical data structure and modulation arrangement according to the present invention;

5 FIG. 8, is a simplified flow chart illustrating a method of the present invention;

FIG. 9 is a simplified front view of a wrist-type monitoring unit worn by an inmate of the institution whose population is being monitored; and

FIG. 10 is a side view of the unit of FIG. 9.

10 DETAILED DESCRIPTION OF THE DRAWINGS

FIG. 1 shows a simplified block diagram of electronic inmate monitoring system 10 according to the present invention. For convenience of explanation and not intended to be limiting, the construction and operation of system 10 is described in terms of application to a prison population, but those of skill in the art will understand, based on the description herein, that system 10 applies to other inmate and institution types as well.

System 10 comprises one or more personal detection units (PDUs) 12. PDUs 12 are small transmitters and are desirably of two varieties: a first variety 14, referred to hereafter as "inmate PDUs" or "inmate transmitters", which are conveniently but not essentially battery operated and worn by inmates (e.g., prisoners and guards) and therefore mobile; and a second variety 16 which have known and generally fixed positions relative to the controlled location region of the institution containing the inmates and are referred to hereafter as "reference PDUs" or "reference transmitters".

In a typical situation, each inmate, whether prisoner or guard, wears an inmate PDU 14. FIG. 9 shows an illustration of a wrist-watch type inmate PDU 14. Reference PDUs 16 may have any convenient configuration and may be battery or line operated. Line operation is preferable for reference PDUs 16.

PDUs 12 transmit coded signals 18 to receptors 20 of receiver nodes 22. Multiple receiver nodes 22 are provided, generally at least three, but more than three provide redundancy and increased accuracy and are desirable. The optimal number of receiver nodes 22 depends upon the size of the institution, the number of rooms, corridors, yards, and other partially or wholly enclosed spaces and any other structural features that might interfere with reception of signals 18 by receiver nodes 22. In general, sufficient number of nodes 22 should be provided so as to avoid any dead spots wherein signals 18 sent from PDUs 12 would not be picked up by at least one receiver node 22, preferably at least three nodes 22.

It is desirable that signals 18 between PDUs 12 and receivers 22 be electromagnetic signals, e.g., radio or optical signals. In a typical embodiment, signals 18 are rf signals with frequency above about 10 MegaHertz, usually above about 100 MegaHertz with about 915 MegaHertz being convenient. Signals 18 are intermittent and random, that is, comparatively short bursts of rf energy occurring at random times within predetermined intervals.

For example, in the preferred embodiment, signals 18 from PDUs 12 have a frequency of about 915 MegaHertz, a duration of about 120 microseconds and occur at random times every 0.5-1.5 seconds. Thus, in the preferred embodiment, at random times within about every 1.0 ± 0.5 seconds interval, each PDU 12 sends a 120 microsecond burst of coded rf energy to receivers 22. Because the timing of the transmission from individual PDUs is random and independent of the timing from all other PDUs, only a small number of coincident transmissions will occur and these will be randomly distributed. Thus, if transmissions from PDUs A and B overlap and interfere during one transmission interval, because each transmission is random with respect to the next and with respect to all other PDUs, the signals from PDUs A and B are unlikely to overlap and interfere during the next transmission interval. For example, with about a 10^{-4} seconds signal burst duration and about a one second transmission interval, then about 10^3 PDUs can be accommodated with a probability of signal overlap of about ten percent. Thus, a large number of PDUs (e.g., 10^3 or more) can be accommodated, and a clear signal obtained from each at least every few transmission intervals. The use of random transmission times of short coded burst transmissions and with transmission intervals that are about 10^3 to 10^5 (preferably about 10^4) times the coded signal duration, is a particular feature of the present invention.

While having an inmate transmission interval of about 1.0 ± 0.5 seconds is preferred, longer or shorter transmission intervals may also be used, for example, transmission intervals in the range of 0.1 - 100 seconds are useful, with about 0.2 - 20 seconds being convenient and 0.5 - 15 seconds being suitable for many situations. In general, having very short transmission intervals (e.g., less than about 0.1 seconds) is undesirable where large numbers of PDUs are intended to be monitored. (If only one PDU is to be monitored, then the transmission interval could be as short as the transmission burst length, but this merely

consumes more power to no advantage.) The longer the transmission interval, the more PDUs that can be accommodated, the lower the average power consumption, and the less the probability of time overlap, but the less frequently the inmate population count and location is updated. Thus, the optimal transmission interval will depend upon the desired system capacity (i.e., number of monitored PDUs) and the desired data refresh rate. Those of skill in the art will understand how to choose the optimum transmission intervals for their particular problem based on the teachings herein.

The forgoing discussion assumes that the transmission intervals of all PDUs are substantially the same, but this is not essential. For example, inmate PDUs may have the same or different intervals and reference PDUs may have the same or different intervals, and the inmate and reference PDU intervals may be the same or different. In the preferred embodiment, the reference PDUs transmit randomly during a nominal transmit interval longer than the nominal transmit interval of the inmate PDUs. For example, unless triggered by receipt of a sonic signal from an inmate PDU, the reference PDUs conveniently randomly transmit about 50-500 times less frequently than the inmate PDUs (e.g., every few minutes rather than about every second), but shorter or longer reference transmit intervals are not precluded.

Further, the nominal transmit time intervals need not be fixed. For example, if an inmate PDU 14 registers an alarm condition, e.g., an attempt to tamper with the PDU (see FIG. 2), it is desirable that the nominal transmit time interval be shortened at least temporarily to increase the probability that the alarm condition coded into signal 18 will be detected and identified by system 10. Thus, when an alarm condition registers in a particular inmate (or reference) PDU, the transmit interval is desirably shortened, for example, from nominally about one second to nominally about 0.1 second. Thus, there is a greater probability that the signal from this particular PDU will be reliably received by the system, i.e. without collisions. After a predetermined interval, e.g., about 1-10 seconds, the PDU desirably resets to the pre-alarm transmit interval. This helps avoid having momentary false alarm conditions overwhelm the system.

Referring again to FIG. 1, coded (e.g., rf) signals 18 are passed to multiple receiver nodes 22 where they are correlated and detected and the resulting data and timing information passed to collector nodes 24. Each collector node 24 serves a number of receiver nodes, as for example four receiver nodes 22 per collector node 24, but more or fewer is also suitable. Collector nodes 24 determine differences in time of arrival of signals 18 from transmitters 12 at receptors 20 and separate the identification codes carried by signals 18 identifying each transmitter 12 so that the two kinds of information are related, i.e., the particular relative arrival time of the signal from a particular PDU is identified and the position and status of each PDU (from which a valid signal was received) calculated therefrom. This information is then passed over two-way communication link 28 to central control station 26 where the inmate count, position and status information is determined, stored, updated and made available to the system operators.

Bar code reader 30 may also be provided in the system for reading bar codes on inmate PDUs for accounting or other purposes. Bar code readers 30 may be located at choke points in the institution for verifying passage of particular inmate PDUs or on vending machines or in the library or sports equipment room or the like for facilitating inmate purchases and book or sporting equipment withdrawals, or dispensing medications or other functions involving accountability.

System 10 desirably but not essentially also includes sonic emitters 13 on inmate PDUs 14. Sonic emitters 13 provide sonic signals 15 (e.g., a short CW burst), at the same random time at which individual inmate PDU 14 transmits its coded signal 18, but not necessarily with the same transmission interval. Sonic signal 15 is desirably ultrasonic, so as to not disturb the inmate wearing the PDU. Generally, sonic signals 15 are not transmitted every time rf signal 18 is transmitted but are transmitted less frequently. However, whenever sonic signal 15 is transmitted from a PDU, transmission occurs at the same time as transmission of rf signal 18 from that same PDU.

Reference PDUs 16 have microphones or other sonic receptors 17 which receive sonic signals 15 from nearby inmate PDUs 14. Whenever a reference PDU (e.g., 16) receives a sonic burst, it promptly transmits coded signal 18 identifying itself and containing an additional code indicating that it has received a sonic signal. The difference in arrival time of signal 18 from an individual PDU 14 and the signal 18 from a reference PDU 16 activated by a sonic burst from that inmate PDU allows substantial improvement in the accuracy to which the position of the inmate PDU can be determined. This is because the arrival time differences allow the sonic propagation time (and therefore the range) from inmate PDU to adjacent reference PDU to be determined. Since the sonic propagation velocity is much slower than the rf propagation velocity, the range (and therefore inmate PDU position relative to the reference PDU) can be determined with much greater accuracy than is possible by the use of rf alone.

It should be noted that system 10 is conveniently a one-way system, that is, the inmate PDUs need have no signal reception capability. It has been determined that a one-way system where the inmate PDUs only transmit in brief bursts (either rf alone or rf and sonic or sonic alone), consumes less power than a

system where the inmate PDUs must also have a continuously operating receiver to listen for a polling signal from a central monitoring system, even when polling is substantially less frequent than the transmission intervals used herein. This is a particular feature of the present invention.

A further feature of system 10 is that receptors 20 need not be particularly directional since the location of PDUs 12 is determined primarily from differences in time of arrival of signals 18 at receptors 20 and receivers 22, taking advantage of the calibration provided by reference PDUs 16.

Reference PDUs 16 have known and substantially fixed positions. Hence, the arrival times of their signals provide a local calibration that takes into account local variations in the environment and other system drift or anomalies to aid in more accurately determining the position of nearby inmate PDUs 14. Also, since reference PDUs are transmitting at frequent intervals, the system can continuously self-calibrate. Thus, drift in individual components or transmission lines or other elements that might affect the accuracy of determining relative time-of-arrival of signals 18 are automatically compensated. This is a further particular feature of the present invention.

FIG. 2 shows a simplified schematic diagram illustrating the construction and operation of inmate PDU 14. Inmate PDU 14 comprises microcontroller 32 which receives inputs from alarm sensors or switches 34, tampering sensors 36, body sensors 38 and test or other optional input 40, and inserts indications of the status of these inputs into coded signal 18. While certain sensors or alarm or test indicators 34-40 are illustrated, those of skill in the art will understand that any types of status or alarm or test indicators can be included depending upon the function or condition to be detected and reported as a part of the monitoring function, and those illustrated in FIG. 2 are intended to be representative rather than limiting (see also the discussion in connection with FIG. 7).

Microcontroller 32 also communicates with regulation and control unit 42 which manages power from battery 44, and supplies power via outputs A, B, C, etc. to various operational circuits 46-54, as microcontroller 32 directs. This is important to provide extended battery life by energizing only those circuit elements that are required for a particular function being performed. Controller 32 also desirably supplies time of day display 56 but this is not essential.

When commanded by microcontroller 32 based on instructions stored within memory 33, phase locked oscillator 46 produces an rf signal (e.g., 915 MegaHertz) for delivery to modulator 50 and a lower frequency signal (e.g., 14.3 MegaHertz) for delivery to pseudo-random (PN) code generator 48. It is desirable but not essential that the two frequencies be coherent. Code generator 48 also receives inputs from microcontroller 32 which instructs it which codes to insert into modulation signal 49 (e.g., based on the status of indicators 34, 36, 38, 40) delivered to modulator 50. Modulator 50 produces modulated signal 51 which is passed through optional band pass filter 59 to amplifier 52 and sent to antenna 58 to radiate coded signal 18 (e.g., about 120 microseconds duration) to receptors and receiver nodes 20, 22 (FIG. 1). Microcontroller 32 also desirably (but not essentially) provides sonic signal 60 to amplifier 54 and sonic transducer 13 to provide sonic pulse 15, e.g., of about 1 millisecond duration.

Microcontroller 32 and memory 33 include a random number generating routine (and therefore provide a random number generator) which determines when signal 18 (and 15) will be transmitted within the predetermined transmit interval (e.g., about 1 second). Random number generating routines or generators are well known in the art.

FIG. 3 is a simplified block diagram of the circuit of reference PDU 16. Reference PDU 16 contains the core of inmate PDU 14, that is, those elements enclosed by dashed line 14' on FIG. 2, plus optional sonic microphone 17, amplifier 62, filter 64, amplifier 66 and detector 68. Tamper detection element 36 having a similar function to element 36 in FIG. 2 is also provided. Sonic receptor chain 17, 62, 64, 66, 68 provides input 69 to microcontroller 32 within PDU core 14' to activate transmission of signal 18 when a sonic pulse is received at detector 17, as has been previously described. The output of PDU core 14' is coupled to antenna 58 for transmission of signal 18 to receptors and receiver nodes 20, 22, in the same manner as for inmate PDU 14, except that a transmission takes place whenever sonic signal 15 is received and not just at the random times generated within core 14'. The two situations are distinguished by the presence of a code in signal 18 indicating the presence (or absence) of a sonic signal in the transmission from reference PDU 16.

FIG. 4 shows a simplified schematic diagram of receiver node 22. Signal 18 is received at antenna 20 (e.g., where signal 18 is rf) and passed to bandpass filter 70 and low noise amplifier 72. The resulting amplified signal is passed to mixer 74 where it is mixed with signal from local oscillator 76 to provide an IF signal for delivery to IF amplifier 78 and limiter 80. After limiting, the signal is passed to correlator 82, amplifier 84, detector 86, amplifier 88, DC block 90 and hence via output 91 to collector node 24 (FIG. 1). Output 92 of DC block 90 is passed to DC regulator 94 for regulation of the DC voltage provided to the above-described elements of receiver node 22. Correlator 82 is desirably a Surface Acoustic Wave (SAW)

correlator having a correlation function matched to the signal configuration of a common code contained on signals 18 transmitted from all PDUs 12. Elements 70-94 are conventional and well known in the art.

The purpose of correlator 82 is to provide a large output when a unique common code present on all signals 18 is detected and substantially not otherwise. This is accomplished by having correlator 82 check the incoming signals for the presence of the particular common code inserted by all PDUs on signal 18. When the common code is present on the received signal, correlator 82 provides a large (e.g., high correlation) output. When the common code is not present on the received signal, correlator 82 provides little output (i.e., substantially no correlation). This greatly enhances the ability of receiver 22 to discriminate against spurious signals that may be received by receptor 20, as for example, electrical noise, radiation from other sources than PDUs, and so forth. Correlators for performing such function are well known in the art but a SAW correlator is preferred. The use of a common code in all the PDU signals and of a receiver having a correlation capability keyed thereto to separate the PDU signals from other signals based on correlation to the common code is a particular feature of the present invention.

FIG. 5 shows a simplified schematic circuit diagram of one of collector nodes 24. All collector nodes are conveniently identical, although this is not essential. Collector node 24 receives inputs 91 from multiple receiver nodes 22 (FIG. 1), as indicated by channels 96 (labelled 1-N in FIG. 5) and performs relative time-of-arrival measurements on the pulses arriving from receivers 22 and further processes the pulses to extract the data contained therein (e.g., PDU identity and status), and report this information to central processor 26 (FIG. 1). The number of channels corresponding to each receiver node can range from one to N, where N is generally at least 3 and more usefully at least eight to sixteen, depending upon the physical configuration of the confining space.

Each channel desirably has DC blocker 98 which together with DC blocker 90 (FIG. 4) permits DC current to be sent along the same cable through which the data pulses are flowing from receivers 22 to collector node 24, so that separate power supplies are not required in receivers 22.

The information containing signal from receiver 22 is passed through amplifier 100 and then applied to two threshold circuits 102, 104. Threshold circuit 104 detects logical data "1" and is set relatively high for noise immunity. Absence of a logical data "1" is considered a logical "0". Threshold circuit 102 is used for extracting time-of-arrival information and is set relatively low so as to detect the extreme leading edge of the first received logical data "1". This provides time-of-arrival information since each signal 18 begins with one or more logical data "1" signals. (The data structure is explained more fully in connection with FIG. 7.)

Each channel 96 has its own corresponding high speed counter 106 which measures the time interval between data "1"s in the leading edge of signals 18 (i.e., the preamble/sync portion of signals 18). A time resolution of about one nanosecond or better is desirable.

All channels 106 use a common high speed clock 108 synchronized via a designated receiver node channel providing an input to clock 108 via line 109 coupled to the timing threshold detector 102 of the designated channel. The designated receiver node receives a master synchronizing signal from a preselected and modified reference PDU placed where all receivers can receive it and which has a special "master designation" identification (ID) code on its signal that it transmits to all receiver nodes. This master PDU preferably does not transmit randomly. While this is a convenient means of establishing a master time reference, other suitable means may also be used.

When a PDU (inmate or reference) transmits, its rf signal is received and detected by every receiver node within range. The resulting detected pulses are channeled into collector nodes 24 where time-of-arrival measurements are made and ID and status data are decoded. The collector node then compiles a complete list of the times-of-arrival of each PDU signal using data selector 110 operating under the control of microcomputer 112 and memory 114, to read each of the high speed counters 106. The results are stored along with the PDU ID and status determined by data decoder and combiner 116, as a data record in memory 114. Periodically, e.g., about every 10^{-2} to 10^0 seconds, the most current data in memory 114 is transferred to central control station (CCS) 26 (FIG. 1) via high speed data formatter and communication interface 118 and communication line 120. Bar code reader 30 is coupled to microcomputer 112 by any convenient input means 31, as for example but not limited to, an RS 232 port. Collector nodes 24 conveniently operate from conventional power lines.

FIG. 6 is a simplified schematic diagram of central control station (CCS) 26, comprising, communication interface 122, computer system 124, memory 126, monitor 128, keyboard 130, optional mouse 132 and printer 134, and optional uninterruptible power supply 136. The exact configuration of this system and the particular peripheral devices included depend upon the particular system requirements to be decided by the designer and user. Hence, various peripherals listed above may be omitted or others included, as are needed by the user. The various elements of CCS 26 are conventional and similar to those used in standard work stations or desk-top computer arrangements, and persons of skill in the art will understand based on

the description herein how to combine them or vary them depending upon the results desired. The purpose of CCS 26 is to display the inmate population headcount, location and status as determined from the data collected at nodes 24 (FIGS. 1, 5). Software systems for operating such work stations are well known. Similarly, application programs for displaying and printing various data records, as for example, data on headcount, location and status collected by nodes 24, are also well known in the art. For example, various data base programs and spread sheet programs are able to read in data stored in a file with appropriate data field delimiters and present that data to the viewer or user in a variety of ways, such as for example, graphically or in various tables. Such programs are well known in the art.

FIG. 7 shows, in pictorial form, information on the preferred data and signal structure versus time for the information coded onto signals 18 (FIGS. 1, 4), and how the signals and data appear after partial processing in receivers 22. Trace 140 shows, versus time, the presence of short signal bursts 142 of signal 18 of, e.g., about 120 microseconds duration, occurring randomly at approximately 1 second nominal intervals. Dashed outlines 144 indicate that if an alarm condition was present in the transmitting PDU, the signal bursts would occur more frequently, at least temporarily.

Trace 146 shows the internal structure of typical signal burst 142, i.e., that it is composed of a series of M signal bursts 148 each corresponding to a logical data bit. The M data bits provide coded information concerning the PDU identity (ID) and status. In the example of FIG. 7, signal burst 142 is composed of M = 27 subsidiary signal bursts 148 (or lack thereof), each representing a logical data bit, according to the following bit assignments in time order, shown below.

BIT NUMBER	# BITS	FUNCTION
1 - 3	3	PREAMBLE/SYNC BITS
4 - 16	13	PDU ID NUMBER
17	1	LOW BATTERY ALARM
18	1	TAMPER DETECT ALARM
19	1	BODY SENSE ALARM
20	1	DISTRESS ALARM
21	1	SONIC PULSE DETECTED
22	1	SELF-TEST ALARM
23-27	5	PARITY CHECK

In the preferred embodiment, a logical "1" is represented by the presence of a biphasic modulated signal burst 148 and a logical "0" is represented by the absence of such biphasic modulated signal or the presence of a CW signal or a biphasic modulated signal having a different modulation, as explained below.

While M = 27 is illustrated here by way of example, those of skill in the art will understand that more or less logical data bits can be used depending upon the various PDU conditions desired to be monitored by system 10 (FIG. 1). For example, and not intended to be limiting, a heart beat detector could also be included so that absence of a heart beat would cause an alarm condition, or a moisture detector so that moisture would cause an alarm, or a temperature detector, and so forth. The conditions desired to be monitored determine what types of sensors need to be included in the inmate PDUs and the number of data bits needed to report the relevant variable or sensor status. Thus, M may have a wide range of values depending upon the user's requirements. For a prison situation with the indicated alarm or status conditions, about 27 bits is convenient. In the preferred embodiment, each signal burst 148 (or absence thereof) has a duration of about $120/27 = 4.4$ microseconds, so that the total duration of signal 142 is about 120 microseconds. For different values of M, the durations would change accordingly.

Trace 150 shows the structure of biphasic modulated signal bursts 148. Each biphasic modulated signal burst 148 representing a logical "1" (or "0") is composed of P = (2ⁿ-1) subsidiary signal bursts or sub-bits 152 which are pseudo-random code "chips", an expression well understood in the spread-spectrum art. In the example shown for n = 6, P = 63 which is preferred, although larger or smaller values of n and P can also be used. Each chip 152 comprises a short duration burst of a predetermined frequency having a constant phase. For the example shown using 63 chips, each chip would have a duration of about 70 nanoseconds, determined by the period of the reference frequency provided on output 47 from oscillator 46 of PDUs 14, 16 (see FIG. 2). Where the rf frequency is 915 MegaHertz, then each chip would contain approximately $915/14.3 = 64$ cycles, all of a common phase. PN code generator 48 of PDUs 14, 16 provides a particular sequence of modulation to biphasic modulator 50 (see FIG. 2) such that adjacent chips have the same or different phase according to the code generated in block 48. This produces a signal such as is illustrated in simplified form in trace 154 of FIG. 7, where there is a phase shift or no phase shift

between adjacent chips 152, 156, 158 according to the code being provided by generator 48 to biphasic modulator 50.

The code being provided by generator 48 is predetermined and is common to all PDUs. Thus, signals 18 from PDUs 14, 16 carry two code components, the common code provided by generator 48 which is found on all data bits (signal bursts) representing, for example, logical "1"s, and the PDU ID and status information which is encoded by the presence or absence of signal bursts containing the common code. While the description given above is for the situation where the common code is provided on signals representing logical "1"s, and the absence thereof or CW or some other common code represents logical "0", those of skill in the art will appreciate based on the description herein that this may be interchanged. That is, the common code may represent a logical "0", etc., but this is less desirable.

Trace 160 shows the effect of passing a signal containing the common code through a correlator set to respond to the common code. The first logical data bit burst of signal 142, that is, the first data bit burst of trace 146, is always a logical "1" data burst, that is, a sequence of signal chips 150 containing the common code. Under these circumstances, as shown by trace 160, a large but narrow pulse 162 is obtained from correlator 82 (see FIG. 4) whenever signal 18 arrives containing the common code. Thus, each signal burst 148 representing a logical "1" data bit (in the example of FIG. 7) produces narrow pulse 162 of duration (in this example) of approximately 70 nanoseconds. For logical "0"s, there is no pulse 162. Thus, receiver output 91 provides a stream of pulses 162 for each logical "1", with logical "0" represented by an absence of a pulse. Since the leading edge of signal burst 142 always represents a logical "1" thereby producing a narrow pulse 162 at the leading edge of signal 18, threshold detector 102 (see FIG. 5) is able to accurately determine a relative time of arrival of signal 18 at each receiver 22.

The use of pseudo-random noise code generator 48 (FIG. 2) and biphasic modulator 50 has the further advantage of providing a spread spectrum signal. This is helpful in improving the robustness of the system and reducing the likelihood of false triggering due to spurious signals, since the information is spread over a larger portion of the modulation spectrum than would otherwise be the case with conventional modulation. This is a further feature of the present invention.

FIG. 8 shows simplified flow chart of a computer program useful in CCS 26 (FIGS. 1, 6) for management of the information received from collector nodes 24 (FIGS. 1, 5). As indicated by block 172, information received from nodes 24 is tested in decision block 174 to determine the PDU type (i.e., inmate or reference) and whether the "sonic signal received" bit is set, in decision blocks 176, 178. If the sonic signal bits are set, then sonic and rf time of arrival are matched to the proper PDU in block 180 (barring signal overlap, only a single PDU could produce the observed sonic and rf times of arrival). Further decisions are made in blocks 182 and 184 as indicated and the results blocks 180-184 to update or calibrate or determine location or validate as indicated in blocks 186-194.

The output of blocks 188-194 are fed to block 196 where the indicated operations are performed. A further decision operation is performed as indicated in block 198 and either an operator alerted as shown in block 200 or where there is no indication of a PDU being in a restricted area, the program continues and recycles to block 172 as the next set of input data is received from collector nodes 24.

FIG. 9 shows a front view of wrist type inmate PDU 204 and FIG. 10 shows a side view of the same PDU. Wrist band 206 with locking closure 207 contains embedded wire 208 which provides a tamper alarm in the event the inmate attempts to remove PDU 204. Case 210 of PDU 204 contains the elements depicted in FIG. 2, including optional sonic transducer 13, body sensor 211 and optional time of day display 56. Emergency alarm button 212 is provided for use by inmates to signal a threatening (emergency) situation. To reduce false signals, this alarm function desirably requires that buttons 212 and 214 be simultaneously depressed.

Based on the foregoing description, it will be apparent to those of skill in the art that the present invention solves the problems and achieves the goals set forth earlier, and has substantial advantages as pointed out herein, namely, the system is able to track a large inmate population in a predetermined location region, the system is robust and has a high noise immunity by virtue of its use of spread spectrum modulation techniques and a biphasic modulation common code from all PDUs which is correlated in the receivers, the system provides good accuracy through the use of self calibration of the time-of-arrival position location function by virtue of the placement of reference PDUs at particular known locations in the controlled area, the system provides comparatively low battery drain because of the short pulse nature of the position locating and PDU status signal transmissions, the system provides a variety of valuable PDU status indicators (e.g., tamper, low battery, body sense, distress, self-test, etc.) as well as PDU location, and the system provides an optional high precision mode by use of a sonic signal from the inmate PDUs whose arrival is relayed by the reference PDUs to provide for increased position location accuracy. The system is useful in both large and small monitored regions

While the present invention has been described in terms of particular arrangements and steps, these choices are for convenience of explanation and not intended to be limiting and, as those of skill in the art will understand based on the description herein, the present invention applies to other choices, arrangements and steps, and it is intended to include in the claims that follow, these and other variations as will occur to those of skill in the art based on the present disclosure.

Claims

1. A system (10) for monitoring inmates within a region, the region including a predetermined inmate location, comprising:
 - one or more individual inmate transmitters (14), each coupled to an inmate being monitored, for transmitting at first random intervals within a first prescribed time range, signals (18) containing codes identifying individual inmate transmitters (14);
 - one or more reference transmitters (16) fixed at known positions within the region, for transmitting at second random intervals within a second prescribed time range, signals (18) containing codes identifying individual reference transmitters (16); and
 - radio receivers (22) having multiple antennas (20) placed at predetermined locations within the region for receiving signals (18) from the individual inmate (14) and reference (16) transmitters and determining a location of the individual inmate transmitters (14) in part based on signals (18) received from the reference transmitters (16).
2. The system (10) of claim 1 wherein the individual inmate transmitters (14) and the reference transmitters (16) comprise spread-spectrum modulators (46, 47, 48, 49, 50) for providing spread spectrum signals containing a predetermined spread spectrum code and the receiver (22) comprises a correlator (82) for preferentially detecting the presence of the predetermined spread spectrum code to provide an output pulse (162) for precise determination of times of arrival of the spread spectrum signals (18) from the individual inmate transmitters (14).
3. The system (10) of claim 1 wherein the individual inmate transmitters (14) contain an electrical circuit means (32, 33) for generating a random transmit time within the first prescribed time range.
4. The system (10) of claim 3 wherein the means for generating a random transmit time (32, 33) provides a random time interval of about 0.1 to 100 seconds between successive transmissions.
5. The system (10) of claim 4 wherein the random time interval is about 0.2 to 20 seconds.
6. The system (10) of claim 5 wherein the random transmit intervals are at least part of the time, about 0.5 to 1.5 seconds between successive transmissions.
7. The system (10) of claim 1 wherein the signals (18) provided by the individual inmate transmitters (14) and the reference transmitters (16) are RF signals and wherein the individual inmate transmitters (14) further comprise acoustic radiator means (13) for providing a sonic tone burst (15) substantially coincident with transmission of one of the RF signals (18) from the same individual inmate transmitter (14), and wherein some reference transmitters (16) contain acoustic detectors (17) for detecting sonic tone bursts (15) from inmate transmitters (14).
8. The system (10) of claim 7 wherein some reference transmitters (16) have control means (17, 62, 64, 66, 68, 69) for actuating the reference transmitter (16) on receipt of a sonic tone burst (15) to transmit a further RF signal (18) carrying the identity code of the reference transmitter (16) and a further code indicating that a sonic tone burst (15) has been received.
9. The system (10) of claim 1 further comprising in the individual inmate transmitters (14), an alarm detector (34, 36, 38, 40) for determining when an alarm condition exists at the individual inmate transmitter (14) and a means (32, 33) for adjusting the first prescribed time range to make such range shorter, at least temporarily, when such alarm condition exists.
10. A method for monitoring inmates within a region including a predetermined inmate location region, the method comprising steps of:

EP 0 575 753 A2

transmitting first signals (18) from inmate transmitters (14) coupled to inmates having variable positions relative to the region, wherein the first signals (18) contain a known common code and a further code uniquely identifying each inmate transmitter (14);

5 transmitting second signals (18) from reference transmitters (16) having known positions relative to the region, wherein the second signals (18) contain a known common code and a further code uniquely identifying each reference transmitter (16);

receiving signals (18) at multiple receivers (22), each of the multiple receivers (22) having known positions relative to the region;

10 coupling the received signals (18) through correlators (82) for separating the first and second signals (18) from other signals arriving at the known positions;

determining relative times of arrival of the second signals (18) from the known positions; and

calculating the location of the inmate transmitters (14) based at least in part on the relative times of arrivals of the first signals (18) and the second signals (18) from the known positions.

15

20

25

30

35

40

45

50

55

FIG. 1

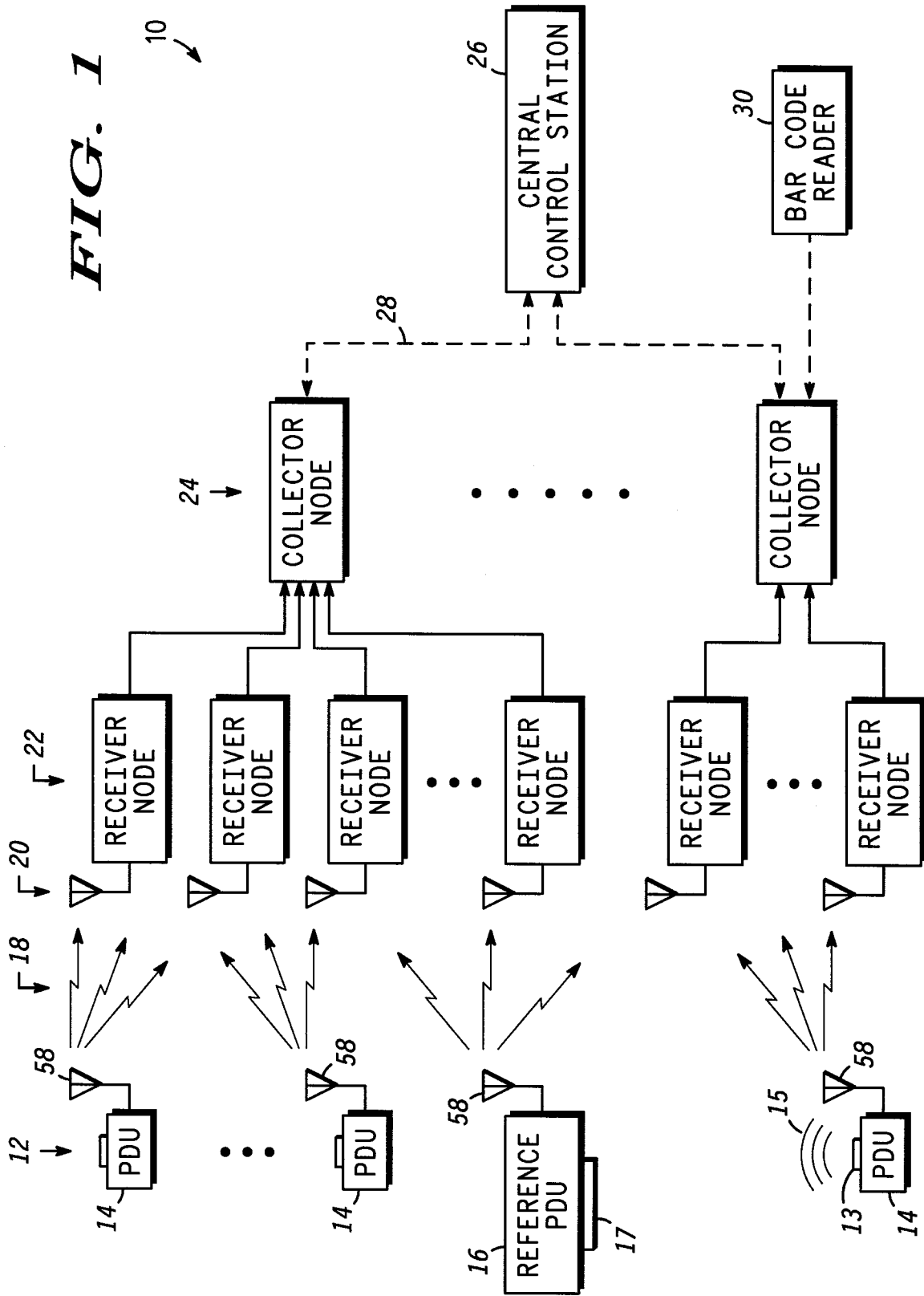

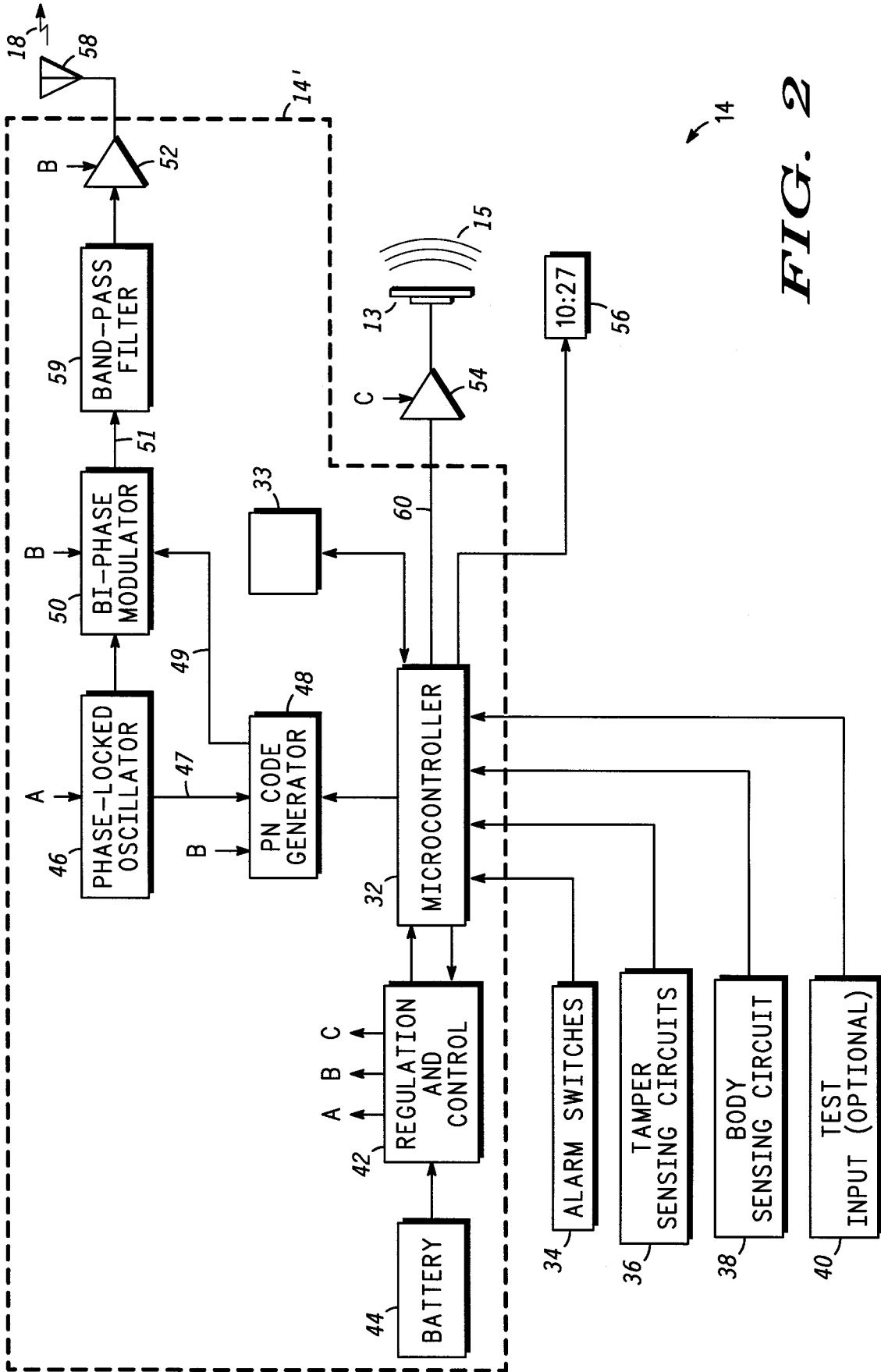

FIG. 2

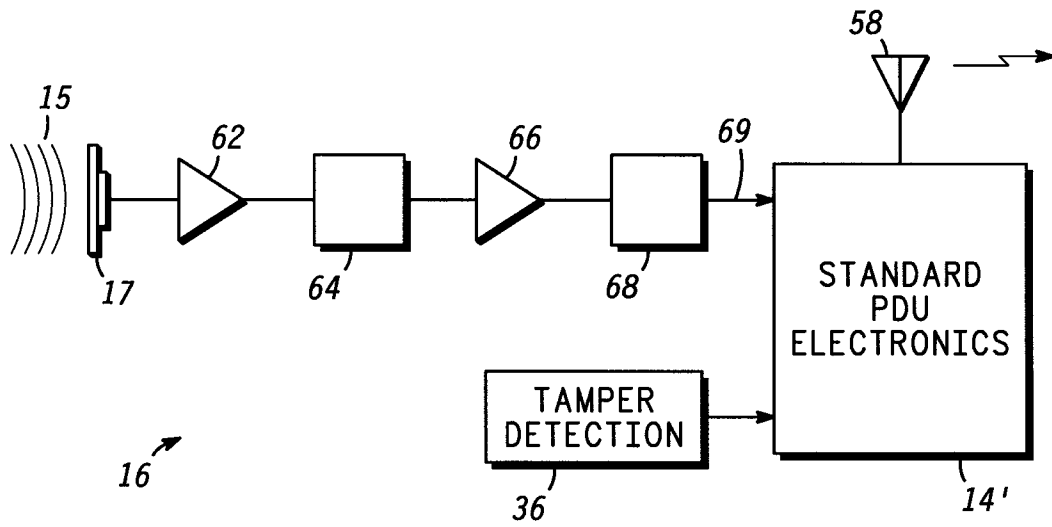
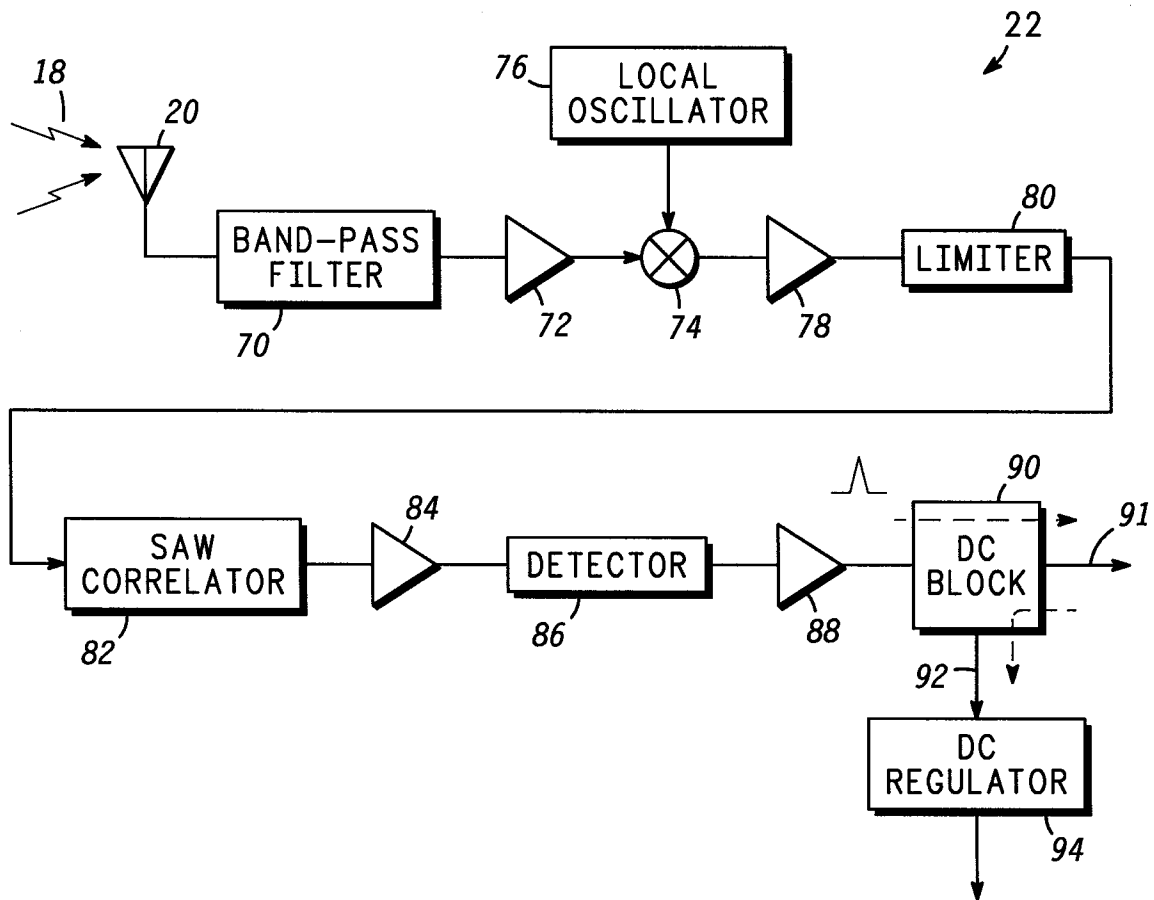

FIG. 3

FIG. 4



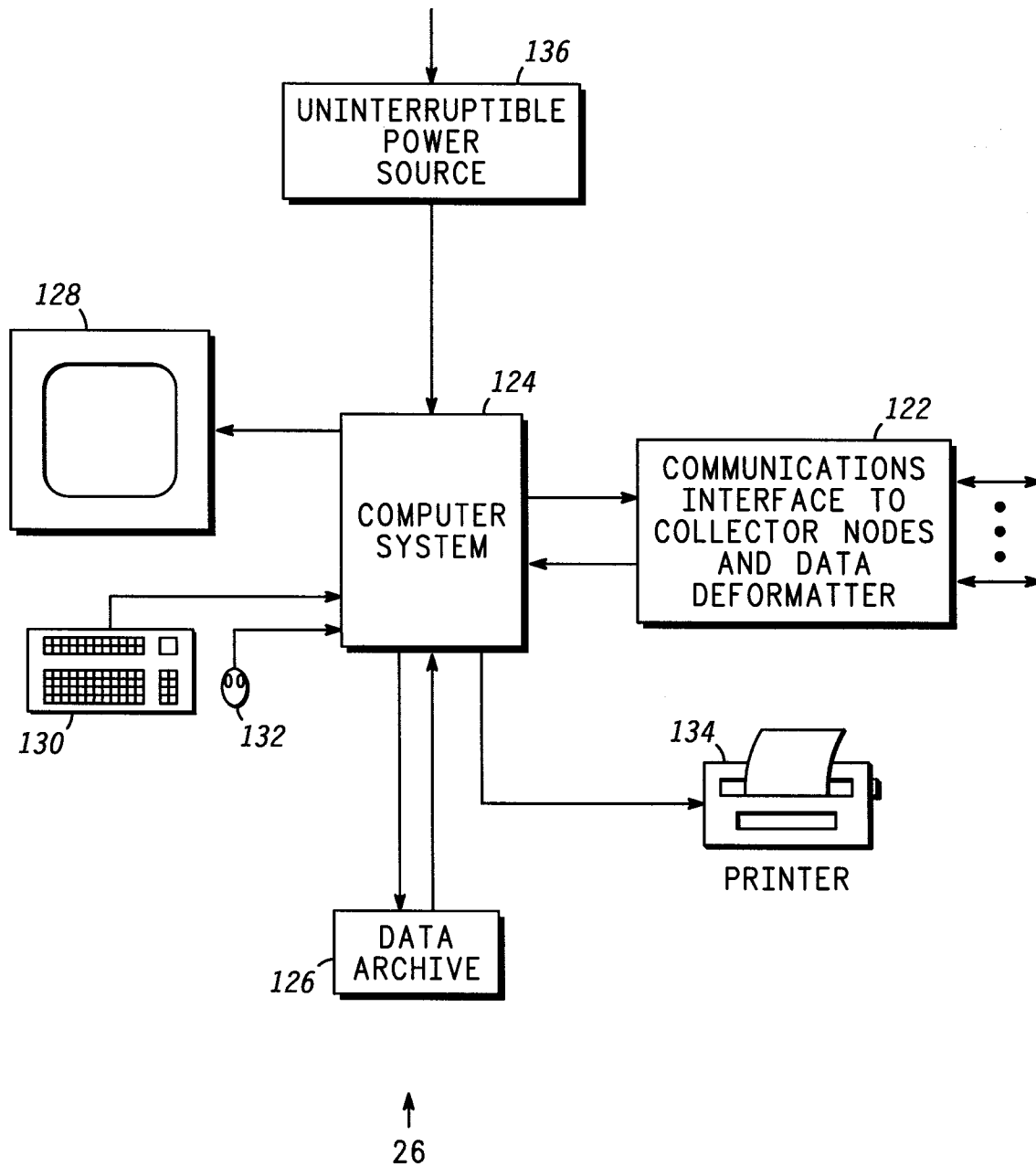

FIG. 6

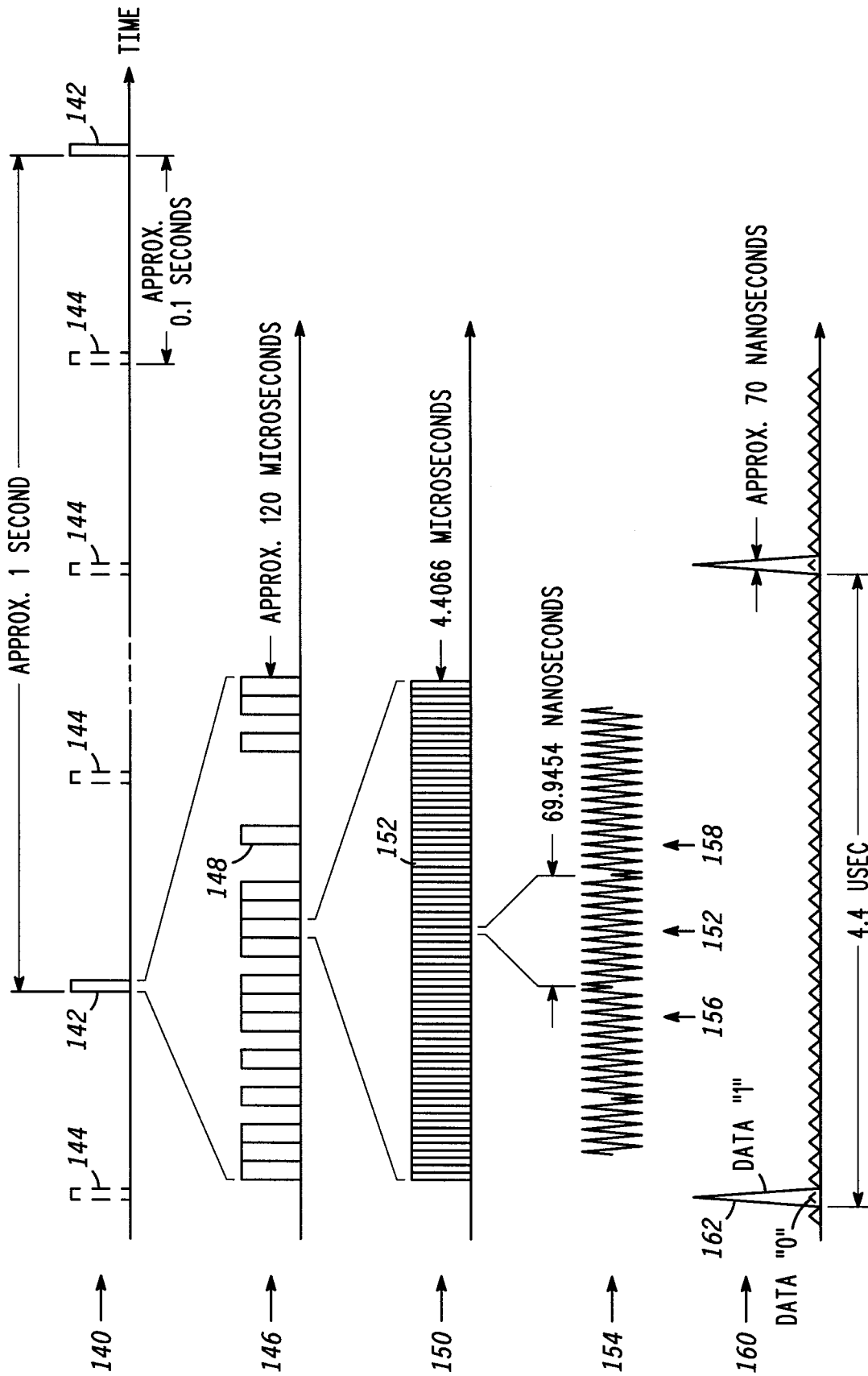
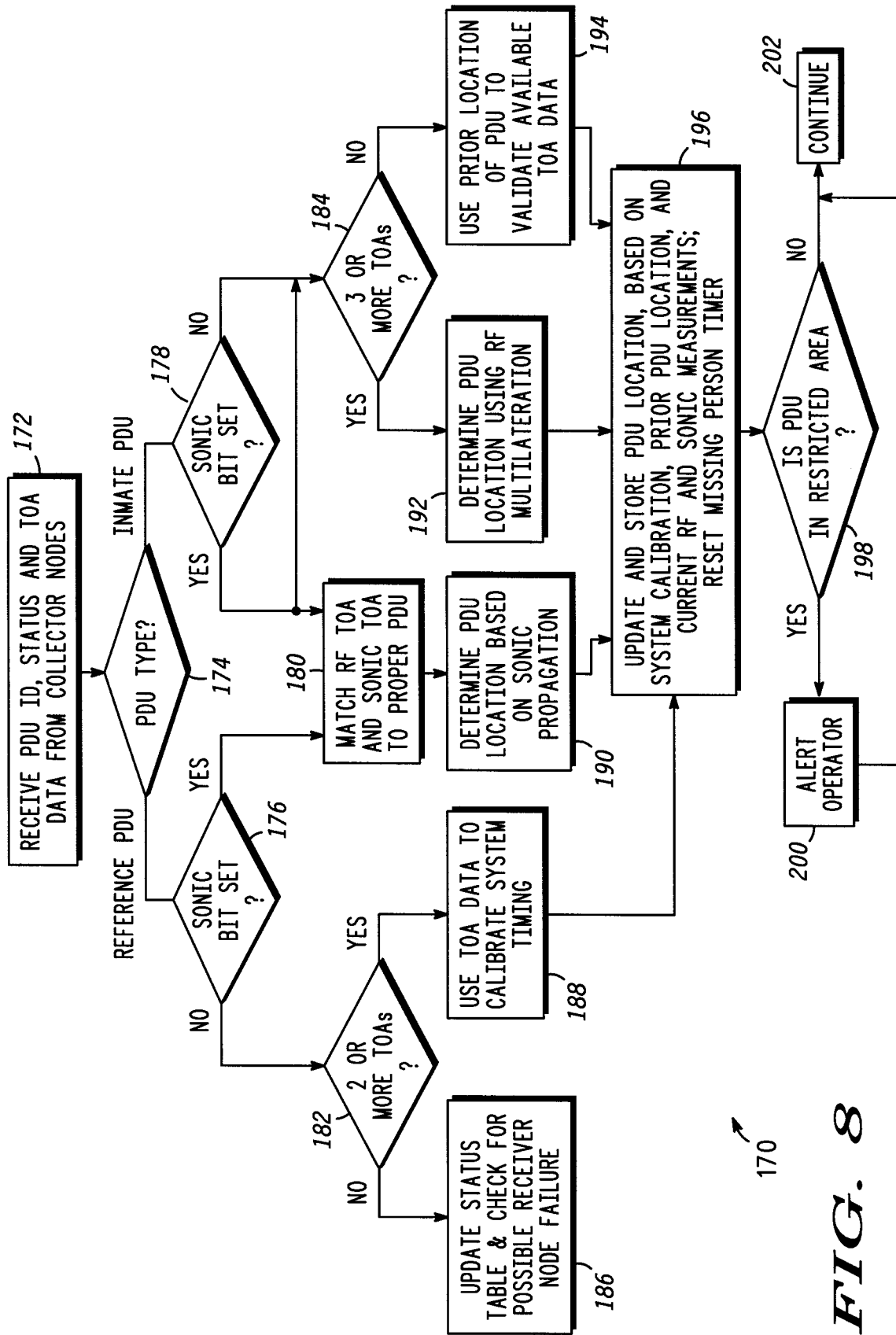

FIG. 7



170
FIG. 8

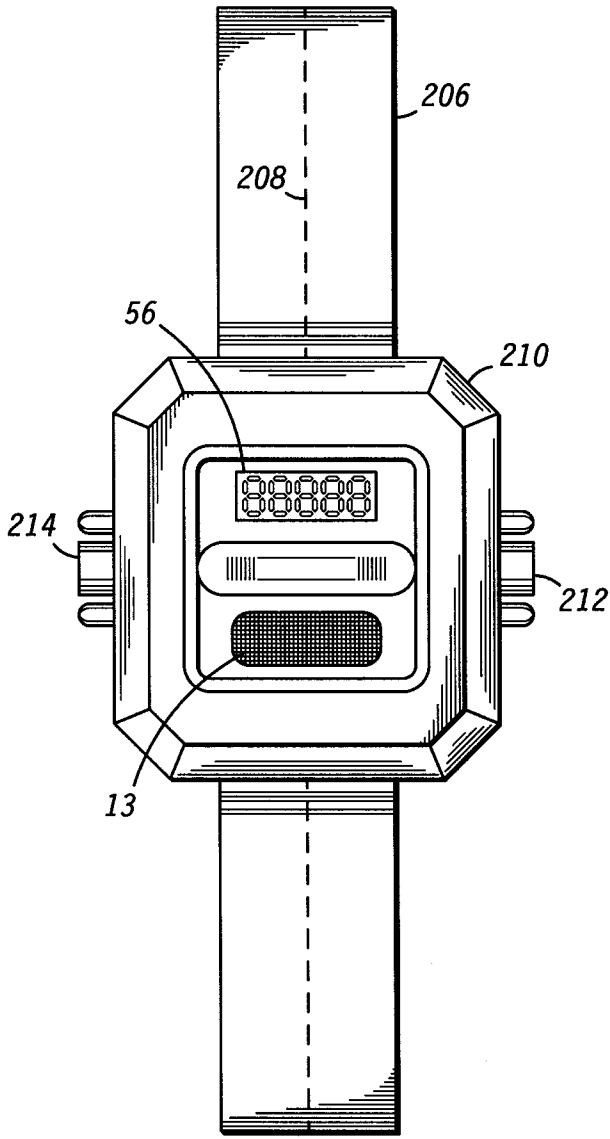

FIG. 9

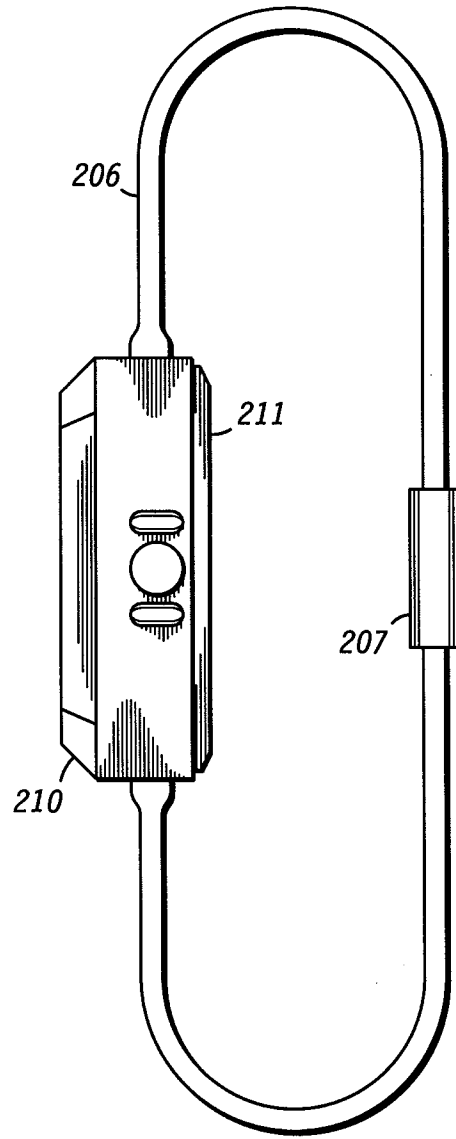

FIG. 10