

**(12) PATENT**  
**(19) AUSTRALIAN PATENT OFFICE**

**(11) Application No. AU 200053464 B2**  
**(10) Patent No. 733277**

(54) Title

**Label panel container carrier**

(51)<sup>6</sup> International Patent Classification(s)

**B65D 071/06**

(21) Application No: **200053464**

(22) Application Date: **2000 .08 .17**

(30) Priority Data

(31) Number (32) Date

**09/377000 1999 .08 .18**

(33) Country

**US**

(43) Publication Date : **2001 .03 .01**

(43) Publication Journal Date : **2001 .03 .01**

(44) Accepted Journal Date : **2001 .05 .10**

(71) Applicant(s)

**Illinois Tool Works Inc.**

(72) Inventor(s)

**Robert Olsen**

(74) Agent/Attorney

**PHILLIPS ORMONDE and FITZPATRICK, 367 Collins Street, MELBOURNE VIC 3000**

(56) Related Art

**US 5511656**

**US 4139094**

**US 5884757**

### ABSTRACT

This invention relates to a package of a plurality of containers unitized with a flexible carrier. The carrier is constructed from a plastic planar sheet having a plurality of container receiving openings arranged in longitudinal rows and transverse ranks. A panel extends from a longitudinal edge of the planar sheet that is arranged to either remain flat and tight with respect to the package or, alternatively, follow an external contour of the package.

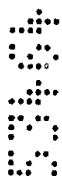

**AUSTRALIA**

Patents Act

**COMPLETE SPECIFICATION  
(ORIGINAL)**

Class      Int. Class

Application Number:  
Lodged:

Complete Specification Lodged:  
Accepted:  
Published:

Priority

Related Art:

---

Name of Applicant:

Illinois Tool Works Inc.

Actual Inventor(s):

ROBERT OLSEN

Address for Service:

PHILLIPS ORMONDE & FITZPATRICK  
Patent and Trade Mark Attorneys  
367 Collins Street  
Melbourne 3000 AUSTRALIA

Invention Title:

LABEL PANEL CONTAINER CARRIER

Our Ref : 617925  
POF Code: 331914/1431

The following statement is a full description of this invention, including the best method of performing it known to applicant(s):

## BACKGROUND OF THE INVENTION

### Field of the Invention

This invention relates to a carrier for unitizing containers having a plurality of container receiving openings configured to allow an integral panel to remain in one of a flat and tight position or a contoured and tight position with respect to the containers. 5

### Description of Prior Art

Conventional container carriers are often used to unitize a plurality of similarly sized containers, such as cans, bottles, jars and boxes, although other packages or containers may be unitized. Plastic ring carriers and box carriers are two such conventional container carriers. 10

The plastic ring carrier produces a unitized package for containers using little material. However, when used alone has little or no advertising or promotional printing space. Conversely, the box carrier generally has a relatively large amount of area for promotional graphics. Disadvantageously, the box carrier requires a relatively large amount of material, permits bottles to fall out if it is not maintained in an upright position, and usually shrouds much of the actual containers. Therefore, there is a need for a package that incorporates the stability and economy of a ring carrier and the promotional area of a box carrier. 15

20

**SUMMARY OF THE INVENTION**

According to the invention in a first aspect, there is provided a carrier for carrying a plurality of containers, the carrier comprising:

- 5 a planar sheet of a plastic material;  
 a plurality of generally triangular container receiving openings arranged in the planar sheet in two longitudinal rows;
- and
- 10 a contour panel extending from a longitudinal edge of the planar sheet;  
 a plurality of panel straps, each panel strap connecting the contour panel with the longitudinal edge of the planar sheet, two panel straps of the plurality of panel straps extending from the longitudinal edge of the planar sheet immediately adjacent a center of the generally triangular container receiving opening.

According to the invention in a second aspect, there is provided a package of a plurality of containers comprising:

- 20 a planar sheet of a plastic material;  
 a plurality of generally triangular container receiving openings arranged in the planar sheet in two longitudinal rows, each generally triangular container receiving opening engaging a container; and
- a contour panel extending from a longitudinal edge of the planar sheet, the contour panel conforming to an external contour of the package.

The invention therefore provides a container carrier that is rim-applied to 25 containers and provides a panel for merchandising information.

Further, the invention provides a container carrier which restricts lateral and vertical movement of the containers with respect to one another.

30 Still further, the invention provides a container carrier that incorporates the stability and economy of a ring carrier and the promotional area of a box carrier.

Yet further, the invention provides a panel that can support the weight of a package of containers if inadvertently used as a handle for the package.

A preferred embodiment of the invention provides a container carrier that maintains a panel in a flat and tight configuration with respect to the unitized containers.

3a

Further, a preferred embodiment of the invention provides a panel on a container carrier that does not protrude from a package of containers and instead follows an external contour of the package.

5 In broad terms, a carrier according to this invention carries a plurality of containers such as cans. The carrier comprises a planar, preferably plastic, sheet formed with a plurality of container receiving openings. The container receiving openings are



formed in longitudinal rows and transverse ranks.

According to one preferred embodiment of this invention, the containers are positioned in each container receiving opening to form a package having a panel that is flat, tight and parallel with respect to the containers and prominent with respect to the package. Such a configuration of the panel results in a package of containers having a prominent display area or "billboard" for advertising, information, graphics and other marketing material. 5

According to another preferred embodiment of this invention, the containers are positioned in each container receiving opening to form a package having a contour panel that follows an external contour of the package. Such a configuration of the contour panel results in a package of containers having prominent display area without the contour panel protruding or otherwise interfering with adjacent packages. 10

#### BRIEF DESCRIPTION OF THE DRAWINGS

The above-mentioned and other features and objects of this invention will be better understood from the following detailed description taken in conjunction with the drawings wherein: 15

Fig. 1 is a top view of a carrier for holding six containers according to one preferred embodiment of this invention;

Fig. 2 is a perspective view of a package of containers using a carrier according to one preferred embodiment of this invention; 20

Fig. 3 is a top view of the package shown in Fig. 2;

Fig. 4 is a top view of a carrier for holding eight containers according to one preferred embodiment of this invention;

Fig. 5 is a top view of a carrier for holding six containers according to another preferred embodiment of this invention;

5

Fig. 6 is a top view of a carrier for holding six containers according to one preferred embodiment of this invention;

Fig. 7 is a top view of a carrier for holding six containers according to another preferred embodiment of this invention;

Fig. 8 is a top view of a carrier for holding six containers according to another preferred embodiment of this invention;

10

Fig. 9 is a perspective view of a package of containers using a carrier according to one preferred embodiment of this invention; and

Fig. 10 is a top view of the package shown in Fig. 9.

#### DESCRIPTION OF PREFERRED EMBODIMENTS

15

Figs. 1-10 show carrier 10 for carrying a plurality of containers 13. Containers 13 shown in Figs. 2 and 9 are preferably cans. Although cans are shown in Figs. 2 and 9, bottles or any other commonly unitized container 13 may be used with carrier 10 according to this invention. Containers 13 are preferably like-sized within a single carrier 10.

20

Carrier 10 unitizes a plurality of containers 13 to create package 11,

such as package 11 shown in Figs. 2 and 9. Carrier 10 comprises planar sheet 15 preferably constructed from a flexible, resilient material such as plastic. In one preferred embodiment of this invention, planar sheet 15 is made from low density polyethylene. Planar sheet 15 preferably comprises two transverse edges 30 and two longitudinal edges 25.

5

Planar sheet 15 of material is preferably cut, using means known to those skilled in the art, such as a stamping die, to form a plurality of container receiving openings 20 in planar sheet 15. Except as otherwise described, container receiving openings 20 are preferably formed in a generally triangular shape having rounded corners. Preferably, six or more container receiving openings 20 are formed in planar sheet 15 in longitudinal rows and transverse ranks. Preferably, container receiving openings 20 are configured in two rows of three ranks or in two rows of four ranks. Planar sheet 15 may include other configurations of container receiving openings 20 depending on the size of package 11 desired. As shown in Figs. 1, 2 and 5-10, in one preferred embodiment of this invention, carrier 10 comprises sheet 15 having six container receiving openings 20. As shown in Fig. 4, carrier 10 comprises sheet 15 having eight or more container receiving openings 20.

10

15

Figs. 1-4 show carrier 10 and package 1 wherein panel 35 is formed to align in a generally flat position relative to package 1. Such a panel configuration results in a large, visible and unobstructed billboard area on a side of package 1. Figs. 5-10 show carrier 10 and package 1 wherein panel 35 is formed to follow

20

external contours of containers 13 within package 1. Such a panel configuration results in a large billboard area on a side of package 1 that does not protrude from package 1 thus reducing the likelihood of snagging or interfering with adjacent packages 1.

As shown in one preferred embodiment of this invention in Figs. 1-4, 5 container receiving openings 20 preferably include corner container receiving openings 22 and center container receiving opening 23. Container receiving openings 20 are preferably longer in a longitudinal direction than wide in a transverse direction.

Corner container receiving openings 22 are located at an intersection 10 between an outermost row of the longitudinal rows and an outermost rank of the transverse ranks. Each carrier 10 includes four corner container receiving openings 22 located at each of four corners of the generally rectangular planar sheet 15. Corner container receiving openings 22 preferably have a reduced longitudinal length relative to container receiving openings 20 not positioned in corners of planar sheet 15. According to one preferred embodiment of this invention shown in Fig. 1, corner container receiving openings 22 include a corner at an extremity of planar sheet 15 having a larger radius than the remaining corners in container receiving openings 20. In addition, as shown in Fig. 4, corner container receiving opening 22 may include a generally straight edge along transverse edge 30 of planar sheet 15. 20

According to one preferred embodiment of this invention, corner

container receiving opening 22 is asymmetrical about apex 27 of corner container receiving opening 22. Preferably, corner container receiving openings 22 are shortened on a side of apex 27 closest to the outward extremity of planar sheet 15. Therefore, a corner radius of each corner container receiving opening 22 at the four outward extremities of planar sheet 15 is larger than the radii of the remaining corners of container receiving openings 20.

5

According to one preferred embodiment of this invention shown in Figs. 1 and 2, center container receiving opening 23 of the plurality of container receiving openings 20 is located between corner container receiving openings 22. Center container receiving opening 23 is positioned in planar sheet 15 adjacent an approximate center of longitudinal edge 25.

10

In part because four corner container receiving openings 22 of the plurality of container receiving openings 20 each have a shortened longitudinal length, carrier 10 preferably has a non-uniform pitch. Pitch is a dimension between a center point of adjacent container receiving openings 20 in the longitudinal rows. The pitch is traditionally important because that dimension must be maintained for conventional applying equipment used to apply carrier 10 onto containers 13. A non-uniform pitch between longitudinally adjacent container receiving openings 20 results in non-uniform stretching of carrier 10 during application to containers 13.

15

In one preferred embodiment of this invention, panel 35 is integrally formed with sheet 15 and extends from longitudinal edge 25 of sheet 15. Panel 35

20

preferably has an overall longitudinal panel length approximately equal to an overall length of longitudinal edge 25. Panel 35 preferably accommodates, on one or both sides, UPC and proof of purchase labels, graphics, and promotional and/or other information related to contents and/or ingredients of package 11. Panel 35 is preferably generally continuous and unbroken, without cutouts or apertures, throughout its defined area. 5

Panel 35 preferably extends outward from longitudinal edge 25 of sheet 15. According to one preferred embodiment of this invention, two end straps 40 connect panel 35 to longitudinal edge 25 of planar sheet 15. Specifically, each end strap 40 connects panel 35 with a corner of longitudinal edge 25 of planar sheet 15. End straps 40 are preferably narrow and positioned at an extremity of the corner to influence wrap around of carrier 10 with respect to containers 13. 10

In addition, center strap 45 connects panel 35 with an approximate center of longitudinal edge 25 of planar sheet 15. Center container receiving opening 23 of the plurality of container receiving openings is positioned in planar sheet 15 directly adjacent center strap 45. Planar sheet 15 immediately adjacent center container receiving opening 23 includes depression 50 that extends toward center strap 45. 15

End straps 40 and center strap 45 are preferably formed of sufficient size and shape to form a solid connection with planar sheet 15. End straps 40 and center strap 45 additionally assist in maintaining panel 35 in a flat position with 20

respect to package 11 to increase visibility and promotional area of carrier 10. A width of center strap 45 is preferably optimized to maintain such a flat position. Preferably, center strap 45 is wider than end straps 40.

As shown in Figs. 1, 2 and 4, panel 35 is preferably tapered along transverse panel edges 37. Panel 35 preferably extends longitudinally for a length approximately equal to an entire longitudinal length of planar sheet 15. Panel preferably additionally extends in a transverse direction for a height approximately equal to a height of container 13.

As shown in Figs. 2 and 3, container 13 is positioned in each container receiving opening 20 to form package 11. According to one preferred embodiment of this invention, panel 35 is preferably flat and parallel with respect to containers 13 and prominent with respect to package 11. If panel 35 is curled or folded in a perpendicular position with respect to package 11, then advertising or other material positioned on panel will not be legible to a consumer. In addition, panel 35 that protrudes with respect to package 11 will create difficulties in packaging, handling and stacking packages 11 because of interference between panels 35 of adjacent packages 11 and between panel 35 and packaging equipment.

Several of the above described features of carrier 10 facilitate a flat and prominent panel 35 with respect to package 11. For example, the generally straight edges formed by portions of container receiving openings 20 adjacent longitudinal edge 25 urges panel 35 into a generally flat position with respect to containers 13 in



package 11. In addition, the non-uniform pitch between longitudinally adjacent container receiving openings 20 also aids in the relative flatness of panel 35 with respect to package 11 because of non-uniform stretching of carrier 10 during application to containers 13.

The attachment points at end straps 40 and center strap 45 also create a flat panel 35 with respect to package 11. A relatively narrow dimension of end strap 40 and the position of end strap 40 at each extremity of package 11 is important for reducing bunching and curling of panel 35 by helping to wrap panel 35 slightly around containers 13 at the ends of package 11. The result of a tight unitized block of containers 13 is a flat panel 35 with respect to package 11.

Depression 50 in planar sheet 15 adjacent center container receiving opening 23 also creates a tighter unitized block of containers 13 within package 11. Depression 50 also assists carrier 10 in retaining containers 13 underneath each respective chime.

As shown in a preferred embodiment of this invention in Figs. 5-10, carrier 10 comprises planar sheet 15 of a plastic material as discussed above. A plurality of generally triangular container receiving openings 20 are preferably arranged in planar sheet 15 in two longitudinal rows.

A plurality of diamond-shaped openings 65 are arranged in a longitudinal row along a center of planar sheet 15 between the two longitudinal rows of container receiving openings 20. As shown in Figs. 5-10, diamond-shaped



openings 65 are preferably positioned so that a single diamond-shaped opening 65 is positioned central to four container receiving openings 20.

Contour panel 70 extends from longitudinal edge 25 of planar sheet 15. Contour panel 70 preferably comprises a panel width less than a length of longitudinal edge 25 of planar sheet 15. Contour panel 70 additionally comprises a height preferably less than half a transverse width of planar sheet 15. 5

A plurality of panel straps 75 preferably extend from longitudinal edge 25 to connect contour panel 70 with planar sheet 15. According to one preferred embodiment of this invention, four panel straps 75 extend from longitudinal edge 25 of planar sheet 15 to connect contour panel 70. Two panel straps 75 preferably extend from a center portion of longitudinal edge 25 of planar sheet 15 and two panel straps 75 preferably extend from outer portions of longitudinal edge 25 of planar sheet 15. 10

According to a preferred embodiment of this invention, each panel strap 75 extending from an outer portion of longitudinal edge 25 extends from an attachment point at, or inside, a transverse center line of outer container receiving openings 20. These attachment points, shown in Figs. 9 and 10, urge contour panel 70 into contoured engagement with containers 13 in package 11. The remaining two panel straps 75 preferably extend from a portion of planar sheet 15 immediately adjacent a center container receiving opening 20. 15 20

According to a preferred embodiment of this invention shown in Fig.

5, an additional contour panel 70 extends from longitudinal edge 25 of planar sheet 15. As shown in Fig. 5, each contour panel 70 extends from common longitudinal edge 25 and each is connected with respect to planar sheet 15 with two panel straps 75.

According to another preferred embodiment of this invention, shown in Figs. 7 and 8, contour panel 70 further comprises center cutout 80. Center cutout 80 assists contour panel with adhering to contour of package 11 in an assembled carrier 10.

In package 11 of a plurality of containers 13 as shown in Figs. 9 and 10, each container receiving opening 20 of the plurality of container receiving openings 20 engages container 13. Diamond-shaped openings 65 preferably form space within central regions of package 11 to create a handle.

Contour panel 70 according to this preferred embodiment of the invention, extends from longitudinal edge 25 of planar sheet 15 and conforms with an external contour of package 11. Such a contoured engagement decreases the potential for protruding sections of carrier 10 to interfere or engage with adjacent packages 11 or other such goods.

Several features enable contour panel 70 to follow the external contour of package 11. A height and length of contour panel 70 are reduced relative to carrier 10 that, in part, enables contour panel 70 to follow the external contour of package 11. In addition, multiple panel straps 75 connecting planar sheet 15 at predetermined

intervals along longitudinal edge 25 assist in retaining contour panel 70 against the external contour of package 11. Specifically, two panel straps 75 connecting longitudinal edge 25 directly adjacent a center rank container receiving opening 20 and one panel strap 75 connecting longitudinal edge 25 directly adjacent each end rank container receiving opening 20.

5

While in the foregoing specification this invention has been described in relation to certain preferred embodiments thereof, and many details have been set forth for purpose of illustration, it will be apparent to those skilled in the art that carrier 10 is susceptible to additional embodiments and that certain of the details described herein can be varied considerably without departing from the basic 10 principles of the invention.

It is to be understood that, throughout the description and claims of the specification the word "comprise" and variations of the word, such as "comprising" and "comprises", is not intended to exclude other additives, components, integers or steps.



THE CLAIMS DEFINING THE INVENTION ARE AS FOLLOWS:

1. A carrier for carrying a plurality of containers, the carrier comprising:

a planar sheet of a plastic material;

a plurality of generally triangular container receiving openings arranged in the planar sheet in two longitudinal rows;

a contour panel extending from a longitudinal edge of the planar sheet;

and

a plurality of panel straps, each panel strap connecting the contour panel with the longitudinal edge of the planar sheet, two panel straps of the plurality of panel straps extending from the longitudinal edge of the planar sheet immediately adjacent a center of the generally triangular container receiving opening.

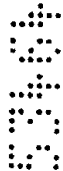

2. The carrier of Claim 1 wherein four panel straps extend from the longitudinal edge of the planar sheet to the contour panel.

3. The carrier of claim 1 or claim 2 wherein two panel straps extend from the longitudinal edge of the planar sheet adjacent a center container receiving opening and one panel strap extends from the longitudinal edge of the planar sheet adjacent each outer container receiving opening.

4. The carrier of any preceding claim, wherein a panel strap extends from each end of the longitudinal edge of the planar sheet.

5. The carrier of any preceding claim, wherein the contour panel contains a center cutout.

6. The carrier of any preceding claim, further comprising an additional contour panel extending from the longitudinal edge of the planar sheet.

7. A package of a plurality of containers comprising:

a planar sheet of a plastic material;

a plurality of generally triangular container receiving openings arranged in the planar sheet in two longitudinal rows, each generally triangular container receiving opening engaging a container; and

a contour panel extending from a longitudinal edge of the planar sheet, the contour panel conforming to an external contour of the package.

8. The package of Claim 7 further comprising an additional contour panel extending from the longitudinal edge of the planar sheet, the additional contour panel also conforming to the external contour of the package.

9. The package of claim 7 or claim 8 further comprising two panel straps extending from the longitudinal edge of the planar sheet immediately adjacent a center triangular container receiving opening to the contour panel.

10. A carrier substantially as herein described with reference to the accompanying drawings.

11. A package substantially as herein described with reference to the accompanying drawings.

DATED: 16 August, 2000

PHILLIPS ORMONDE & FITZPATRICK

Attorneys for:

ILLINOIS TOOL WORKS INC.

*David B Fitzpatrick*



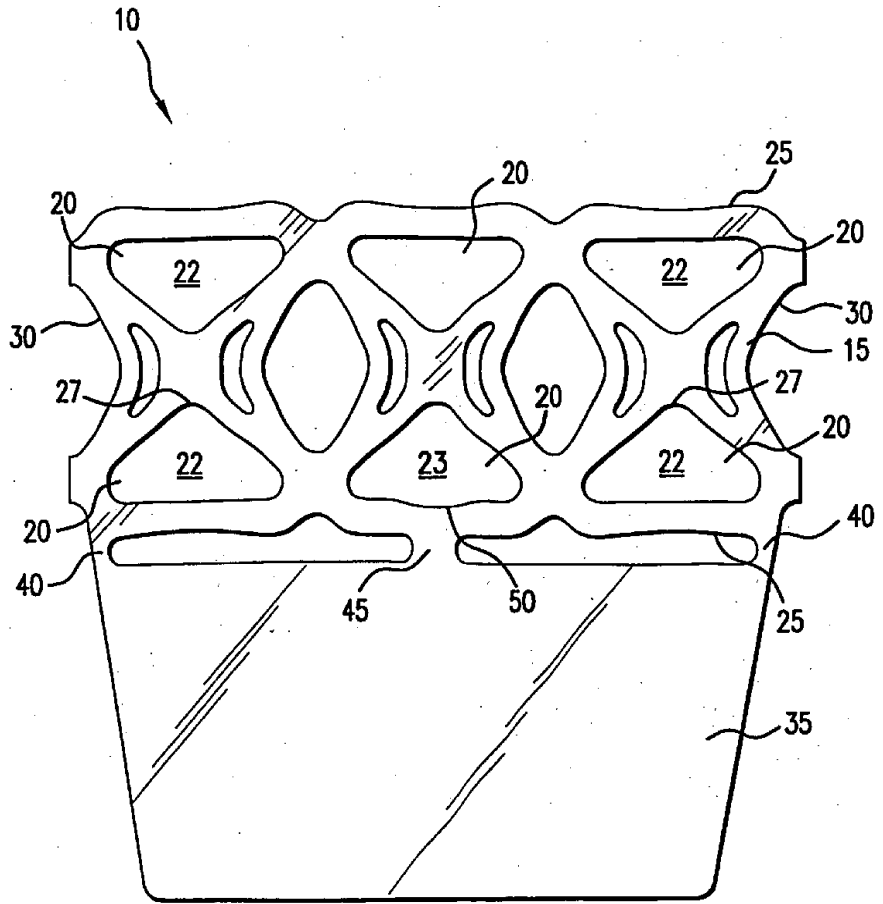

FIG.1

6  
3  
3  
3  
3

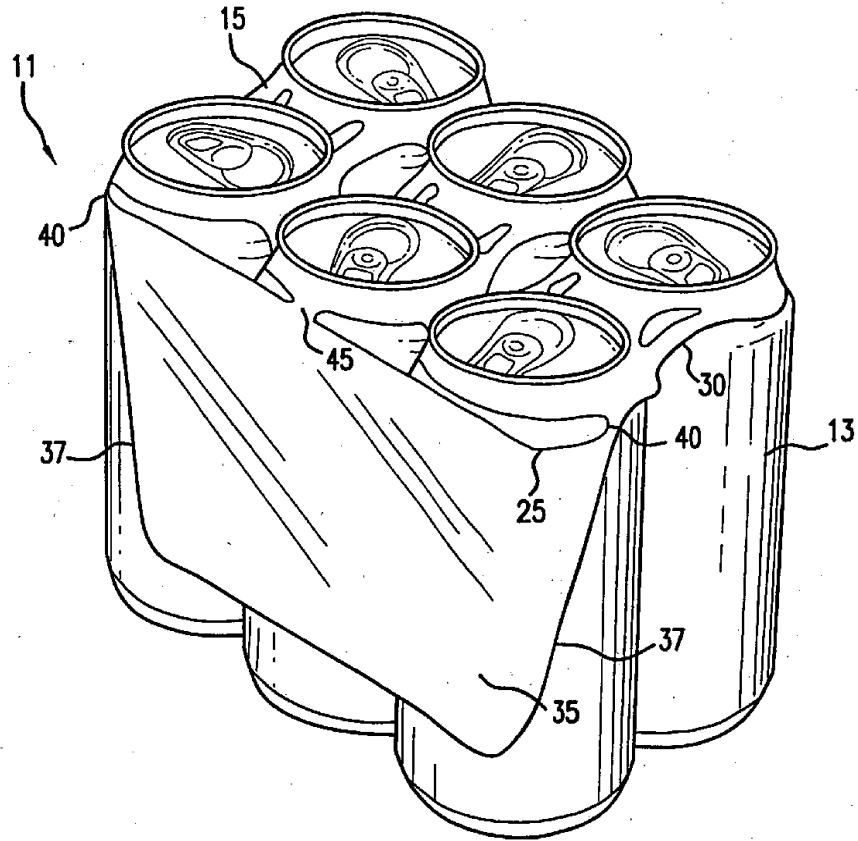

FIG.2



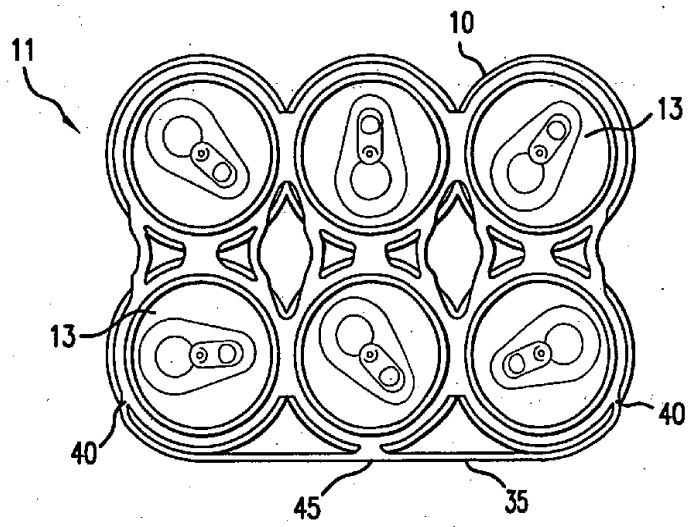
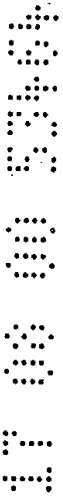

FIG. 3



17 08 00 33464

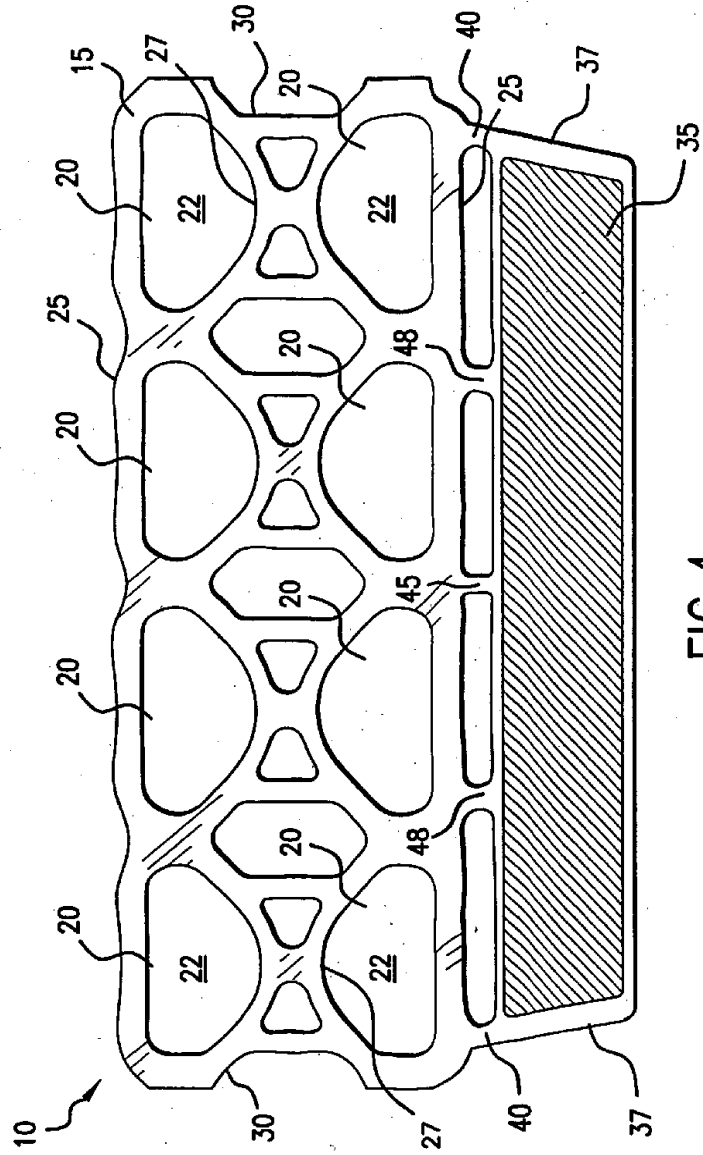

FIG.4

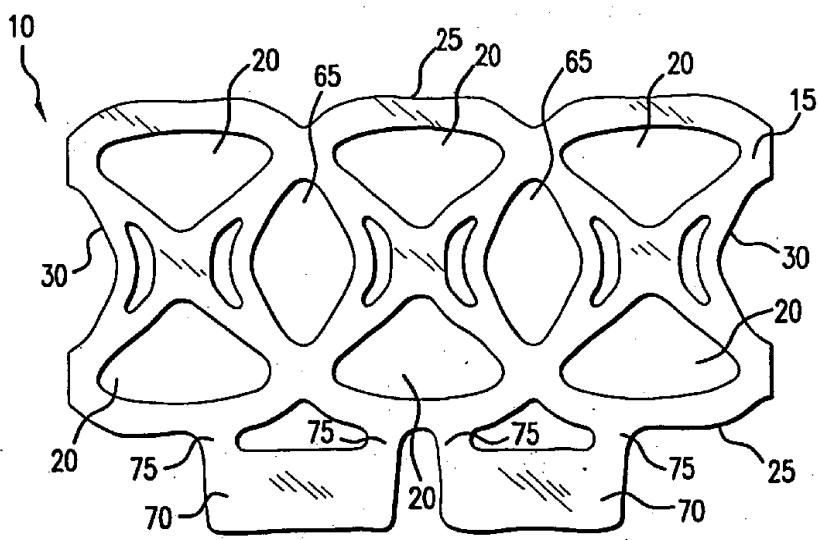

FIG. 5

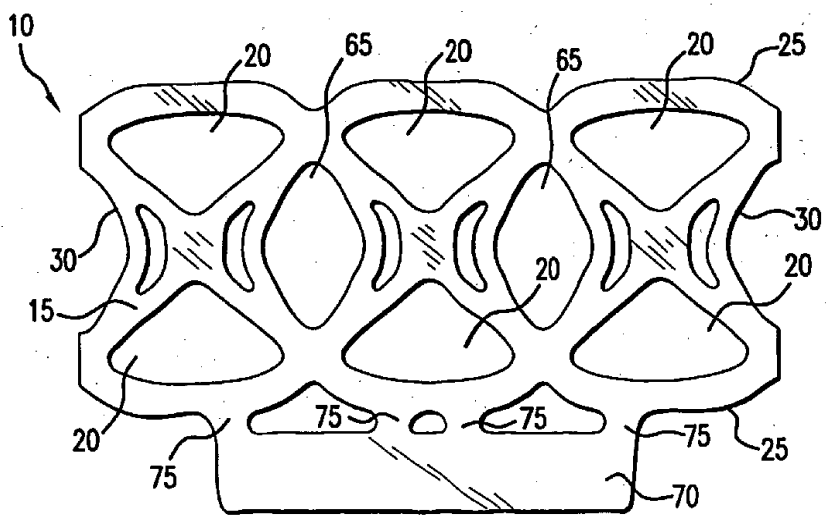

FIG. 6

5  
2  
3  
4

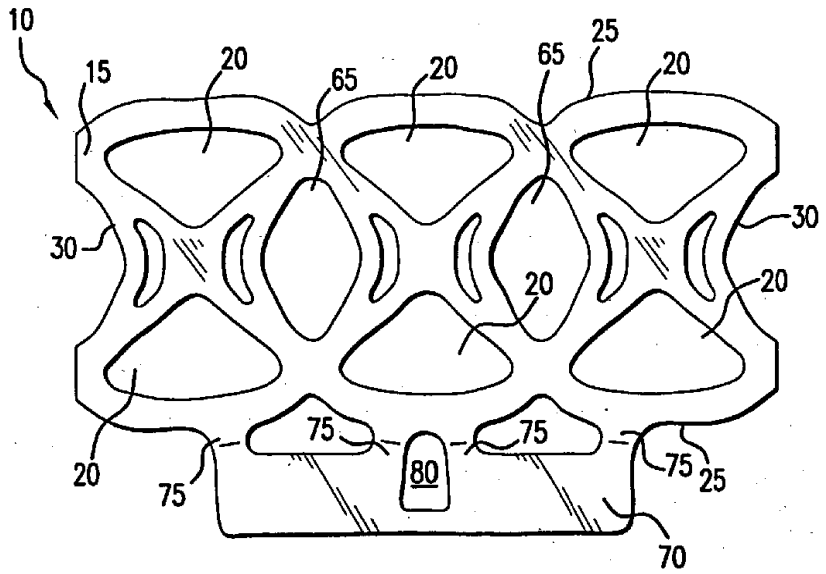

FIG. 7

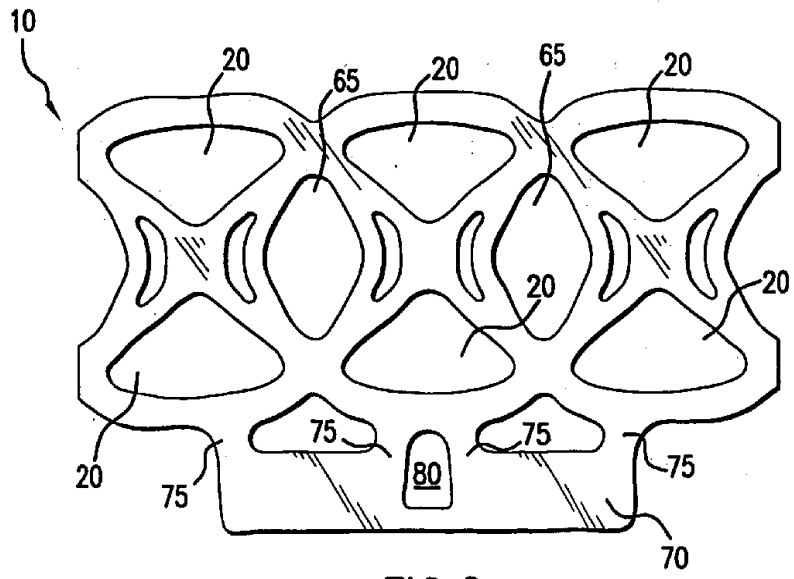

FIG. 8

6  
0  
3  
2  
4

0  
0  
0  
0  
0

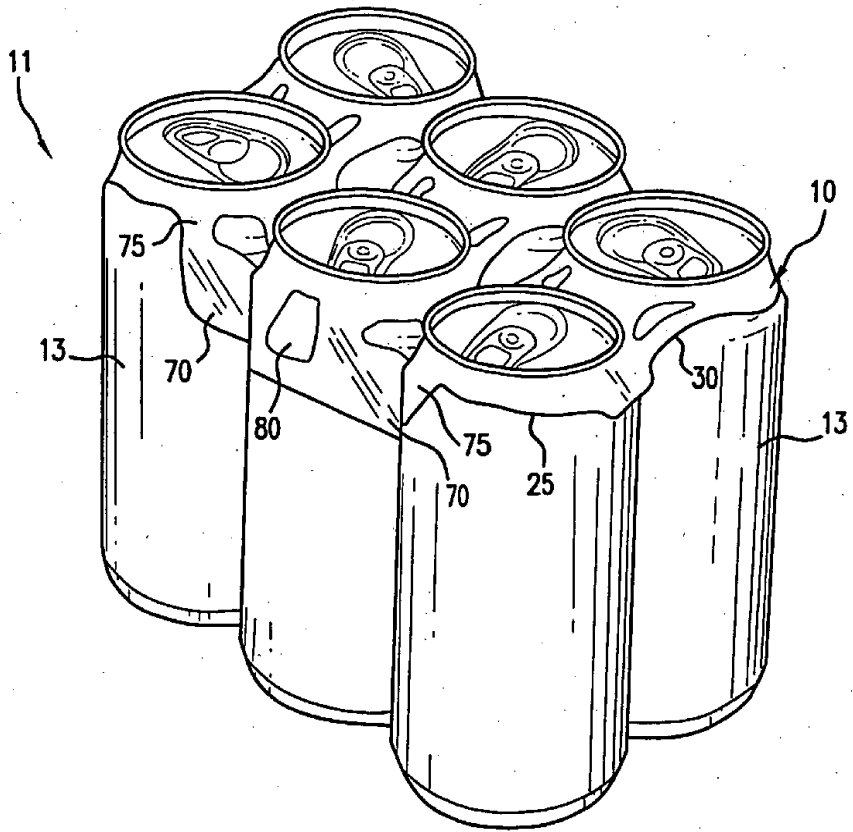

FIG.9

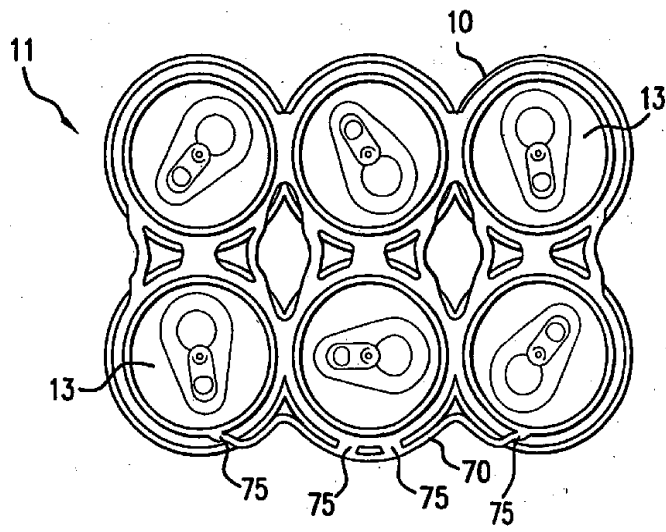

FIG.10

5  
3  
3  
4