



Europäisches Patentamt  
European Patent Office  
Office européen des brevets



(11) EP 0 855 506 A3

(12) EUROPEAN PATENT APPLICATION

(88) Date of publication A3:  
07.01.1999 Bulletin 1999/01

(51) Int. Cl.<sup>6</sup>: F04B 27/18

(43) Date of publication A2:  
29.07.1998 Bulletin 1998/31

(21) Application number: 98101411.1

(22) Date of filing: 27.01.1998

(84) Designated Contracting States:  
AT BE CH DE DK ES FI FR GB GR IE IT LI LU MC  
NL PT SE  
Designated Extension States:  
AL LT LV MK RO SI

(72) Inventors:  
• Taguchi, Yukihiro  
Isesaki-shi, Gunma 372 (JP)  
• Terauchi, Kiyoshi  
Isesaki-shi, Gunma 372 (JP)

(30) Priority: 27.01.1997 JP 12201/97

(74) Representative:  
Prüfer, Lutz H., Dipl.-Phys. et al  
PRÜFER & PARTNER GbR,  
Patentanwälte,  
Harthausen Strasse 25d  
81545 München (DE)

(71) Applicant: Sanden Corporation  
Isesaki-shi, Gunma 372-8502 (JP)

(54) Variable-displacement compressor

(57) A variable-displacement compressor comprises a compressor housing having a crank chamber, a discharge chamber, and a suction chamber. The variable-displacement compressor comprises a driving shaft rotatably supported by the compressor housing to be located in the crank chamber and a slant plate located in the crank chamber to be coupled to the driving shaft. The slant plate has a variable slant angle for the driving shaft. The variable-displacement compressor varies the variable slant angle in accordance with a pressure difference between the crank chamber and the suction chamber to control a compression capacity. The variable-displacement compressor further comprises a first communication path through which the crank chamber communicates with the discharge chamber, a first valve device for adjusting the opening area of the first communication path to control the pressure in the crank chamber, a second communication path through which the crank chamber communicates with the suction chamber, and a second valve device for adjusting the opening area of the second communication path in accordance with the pressure difference. More particularly, the second valve device perfectly closes the second communication path when the pressure difference becomes a predetermined pressure difference.

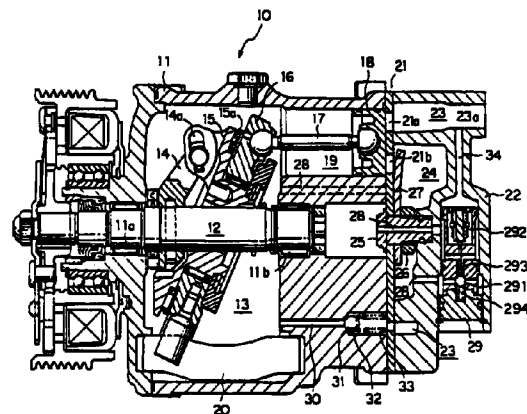

FIG. 1

EP 0 855 506 A3



European Patent  
Office

EUROPEAN SEARCH REPORT

Application Number  
EP 98 10 1411

DOCUMENTS CONSIDERED TO BE RELEVANT			
Category	Citation of document with indication, where appropriate, of relevant passages	Relevant to claim	CLASSIFICATION OF THE APPLICATION (Int.Cl.6)
A	US 4 702 677 A (TAKENAKA KENJI ET AL) 27 October 1987 * column 4, line 64 - column 9, line 30; figures 1,2 *	1-6	F04B27/18
A	US 5 145 326 A (IMURA KAZUYA ET AL) 8 September 1992 * column 9, line 3 - column 10, line 3; figures 3,4 *	1-6	
A	JP 63 134181 U (....) * figures 1,2 *	1,7	
A	US 4 723 891 A (TAKENAKA KENJI ET AL) 9 February 1988 * column 3, line 24 - column 9, line 4; figures 1-3 *	1,2	
A	US 5 318 410 A (KAWAMURA CHUICHI ET AL) 7 June 1994 * the whole document *	1,7	
The present search report has been drawn up for all claims			TECHNICAL FIELDS SEARCHED (Int.Cl.6)
			F04B
Place of search	Date of completion of the search	Examiner	
THE HAGUE	12 November 1998	Bertrand, G	
CATEGORY OF CITED DOCUMENTS		T : theory or principle underlying the invention E : earlier patent document, but published on, or after the filing date D : document cited in the application L : document cited for other reasons	
X : particularly relevant if taken alone Y : particularly relevant if combined with another document of the same category A : technological background O : non-written disclosure P : intermediate document		& : member of the same patent family, corresponding document	

EPO FORM 1503 03/82 (P04C01)