

May 15, 1923.

1,455,166

A. R. HINDERLITER

SHADE HOLDER

Filed July 26, 1920

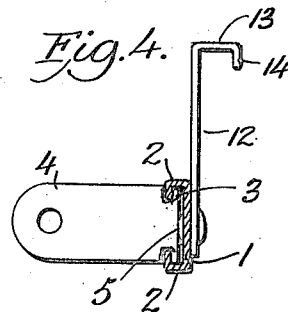
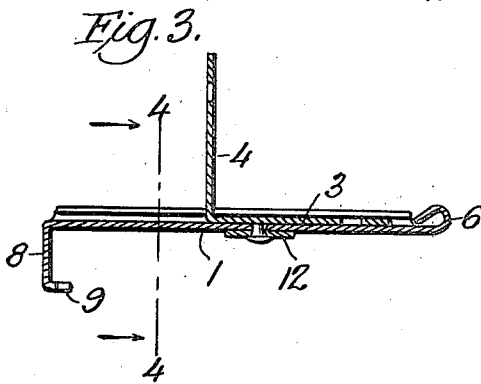
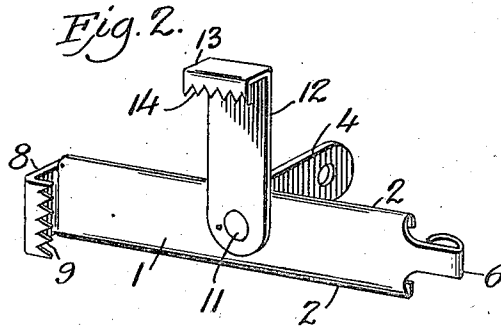
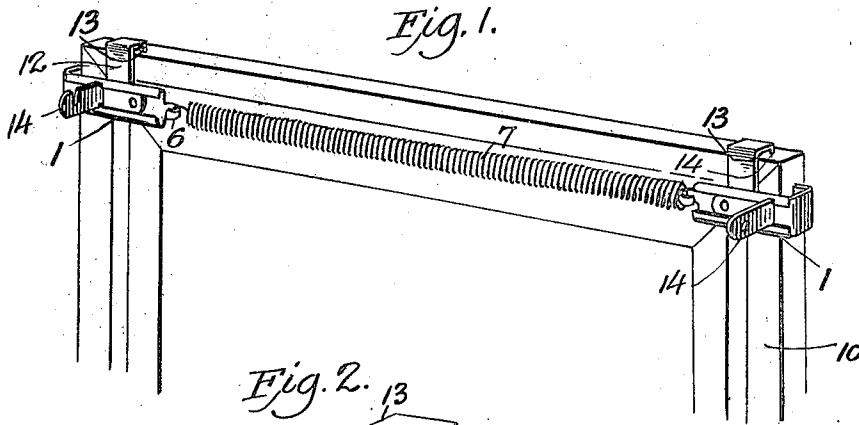

A. R. Hinderliter,

INVENTOR

BY *Victor J. Evans*

ATTORNEY

UNITED STATES PATENT OFFICE.

AMOS R. HINDERLITER, OF FALLS CREEK, PENNSYLVANIA.

SHADE HOLDER.

Application filed July 26, 1920. Serial No. 398,880.

To all whom it may concern:

Be it known that I, AMOS R. HINDERLITER, a citizen of the United States, residing at Falls Creek, in the county of Clearfield and State of Pennsylvania, have invented new and useful Improvements in Shade Holders, of which the following is a specification.

My present invention has reference to a shade holder for windows.

My object is to produce a shade holder including clamps on which the shade brackets are slidably arranged, the said clamps including means for engaging with the sides and with the top of the window casing and are connected with each other by flexible means which bind the clamps against the casing and which means also provides the support for a curtain or drapery.

The foregoing, and other objects which will appear as the nature of the invention is better understood, may be accomplished by a construction, combination and operative arrangement of parts, a satisfactory embodiment of which being illustrated in the drawings accompanying and forming part of this application.

In the drawings:—

Figure 1 is a perspective view illustrating the application of the improvement.

Figure 2 is a perspective view of one of the brackets.

Figure 3 is an approximately central longitudinal sectional view thereof.

Figure 4 is a sectional view approximately on the line 4—4 of Figure 3.

In carrying out my invention I employ two brackets each of a similar construction, and each including a substantially rectangular body member 1 that has its edges intumed, as at 2 to provide guide flanges for the body portion 3 of the angle shade engaging bracket 4. If desired, the body member 3 may be provided with binding means 5, or the flanges 2 may be of sufficient resiliency to exert a tension against the body of the shade bracket to hold the same against the body 1. The body portion 1, at the inner end thereof is reduced and bent upon itself to provide an eye 6, and to the respective eyes of a pair of brackets there are attached the ends of a coil spring 7.

The opposite ends of the body 1 is flanged inwardly, as at 8 and has its end turned in the direction of the said body and toothed,

as at 9. The body portion is designed to be arranged horizontally on the vertical stiles of the window casing 10, and the teeth thereof will be embedded in the edges of the said stiles by the spring which exerts a sufficient tension to perform this object.

On each of the body member 1 there is pivoted, as at 11 the body portion 12 of a clamp. The clamp, has its outer end arranged at an inward angle, as indicated by the numeral 13, and the edge of the said angle portion is down turned or flanged in the direction of the body of the clamp and toothed, as at 14. The teeth 14 are designed to be embedded in the upper member of the window casing 10, and as the said clamps are pivoted to the body member 1, the teeth may be embedded therein by the tension of the spring 7. One of the bracket members is provided with the usual squared notch to receive the squared pintle of the shade roller, and the other with a round opening to receive the round pintle of the shade roller. The body members are each of a sufficient strength to permit of the employment of the device on window casings of varying widths and the coiled spring 7 may be employed as a support for a drapery. When the clamp members are employed, the same may be folded inward of the body members 1 so that their flanged and toothed portions will be received in the flanged and toothed ends of the said body members and the spring may be readily detached from the eyes 6 so that the device may be folded into a compact bundle for storage or shipment.

Having thus described the invention, what I claim, is:—

A shade roller bracket comprising a supporting base of rectangular shape having its longitudinal edges intumed to provide guide flanges, an angle shade engaging bracket received in said guiding flanges, said base having one end reduced and bent upon itself to provide a spring engaging eye, the opposite end of said base being flanged inwardly and the flanged portion being bent at a right angle and toothed, a clamp pivotally secured to the base and having its free end bent and designed to provide gripping teeth as and for the purpose specified.

In testimony whereof I affix my signature.

AMOS R. HINDERLITER.