

(19) World Intellectual Property
Organization
International Bureau



(43) International Publication Date
28 April 2005 (28.04.2005)

PCT

(10) International Publication Number
WO 2005/037078 A2

- (51) International Patent Classification⁷: **A61B**
- (21) International Application Number:
PCT/US2004/034221
- (22) International Filing Date: 15 October 2004 (15.10.2004)
- (25) Filing Language: English
- (26) Publication Language: English
- (30) Priority Data:
10/688,632 17 October 2003 (17.10.2003) US
10/782,131 19 February 2004 (19.02.2004) US
- (71) Applicant (for all designated States except US):
SPINECORE, INC. [US/US]; 475 Springfield Avenue, 4th Floor, Summit, NJ (US).
- (72) Inventors: **ZUBOK, Rafail**; 222 Spruce Street, Midland Park, NJ 07432 (US). **DUDASIK, Michael, W.**; 29 Daily Street, Nutley, NJ 07110 (US). **ERRICO, Joseph, P.**; 29 Deer Path Circle, Green Brook, NJ 08812 (US).
- (74) Agents: **DOHERTY, Michael, J.** et al.; Lerner, David, Littenberg, Krumholz & Mentlik, LLP, 600 South Avenue West, Westfield, NJ 07090 (US).
- (81) Designated States (unless otherwise indicated, for every kind of national protection available): AE, AG, AL, AM, AT, AU, AZ, BA, BB, BG, BR, BW, BY, BZ, CA, CH, CN, CO, CR, CU, CZ, DE, DK, DM, DZ, EC, EE, EG, ES, FI, GB, GD, GE, GH, GM, HR, HU, ID, IL, IN, IS, JP, KE, KG, KP, KR, KZ, LC, LK, LR, LS, LT, LU, LV, MA, MD, MG, MK, MN, MW, MX, MZ, NA, NI, NO, NZ, OM, PG, PH, PL, PT, RO, RU, SC, SD, SE, SG, SK, SL, SY, TJ, TM, TN, TR, TT, TZ, UA, UG, US, UZ, VC, VN, YU, ZA, ZM, ZW.
- (84) Designated States (unless otherwise indicated, for every kind of regional protection available): ARIPO (BW, GH, GM, KE, LS, MW, MZ, NA, SD, SL, SZ, TZ, UG, ZM, ZW), Eurasian (AM, AZ, BY, KG, KZ, MD, RU, TJ, TM), European (AT, BE, BG, CH, CY, CZ, DE, DK, EE, ES, FI, FR, GB, GR, HU, IE, IT, LU, MC, NL, PL, PT, RO, SE, SI, SK, TR), OAPI (BF, BJ, CF, CG, CI, CM, GA, GN, GQ, GW, ML, MR, NE, SN, TD, TG).
- Published:**
— without international search report and to be republished upon receipt of that report
- For two-letter codes and other abbreviations, refer to the "Guidance Notes on Codes and Abbreviations" appearing at the beginning of each regular issue of the PCT Gazette.

(54) Title: INTERVERTEBRAL DISC REPLACEMENT TRIAL

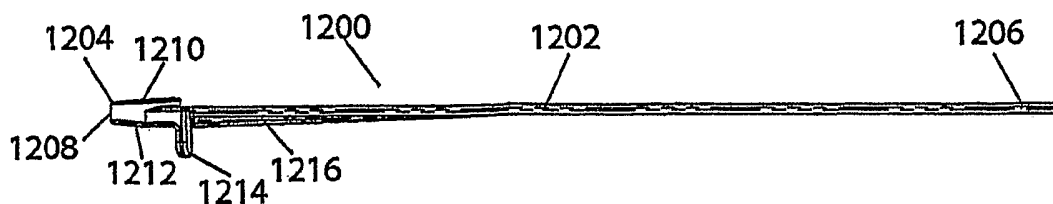

(57) Abstract: An intervertebral disc replacement trial (1200) includes a shaft (1202) having a handle at a proximal end (1206), and a head (1208) disposed at a distal end (1204) of the shaft. The head includes first and second surfaces (1210, 1212) that are spaced apart and sized for insertion into at least one intervertebral disc space defined by respective endplates of an adjacent pair of vertebral bones of a spinal column. The trial facilitates distraction of the vertebral bones in a direction along a longitudinal axis of the spinal column.

WO 2005/037078 A2

INTERVERTEBRAL DISC REPLACEMENT TRIAL

Technical Field

This invention relates generally to systems and methods for use in spine arthroplasty, and more specifically to instruments
5 for inserting and removing cervical disc replacement trials, and inserting and securing cervical disc replacement devices, and methods of use thereof.

Background Art

The structure of the intervertebral disc disposed between
10 the cervical bones in the human spine comprises a peripheral fibrous shroud (the annulus) which circumscribes a spheroid of flexibly deformable material (the nucleus). The nucleus comprises a hydrophilic, elastomeric cartilaginous substance that cushions and supports the separation between the bones while also
15 permitting articulation of the two vertebral bones relative to one another to the extent such articulation is allowed by the other soft tissue and bony structures surrounding the disc. The additional bony structures that define pathways of motion in various modes include the posterior joints (the facets) and the
20 lateral intervertebral joints (the unco-vertebral joints). Soft tissue components, such as ligaments and tendons, constrain the overall segmental motion as well.

Traumatic, genetic, and long term wearing phenomena contribute to the degeneration of the nucleus in the human spine.
25 This degeneration of this critical disc material, from the hydrated, elastomeric material that supports the separation and flexibility of the vertebral bones, to a flattened and inflexible state, has profound effects on the mobility (instability and limited ranges of appropriate motion) of the segment, and can
30 cause significant pain to the individual suffering from the condition. Although the specific causes of pain in patients suffering from degenerative disc disease of the cervical spine have not been definitively established, it has been recognized that pain may be the result of neurological implications (nerve
35 fibers being compressed) and/or the subsequent degeneration of the surrounding tissues (the arthritic degeneration of the facet

joints) as a result of their being overloaded.

Traditionally, the treatment of choice for physicians caring for patients who suffer from significant degeneration of the cervical intervertebral disc is to remove some, or all, of the damaged disc. In instances in which a sufficient portion of the intervertebral disc material is removed, or in which much of the necessary spacing between the vertebrae has been lost (significant subsidence), restoration of the intervertebral separation is required.

Unfortunately, until the advent of spine arthroplasty devices, the only methods known to surgeons to maintain the necessary disc height necessitated the immobilization of the segment. Immobilization is generally achieved by attaching metal plates to the anterior or posterior elements of the cervical spine, and the insertion of some osteoconductive material (autograft, allograft, or other porous material) between the adjacent vertebrae of the segment. This immobilization and insertion of osteoconductive material has been utilized in pursuit of a fusion of the bones, which is a procedure carried out on tens of thousands of pain suffering patients per year.

This sacrifice of mobility at the immobilized, or fused, segment, however, is not without consequences. It was traditionally held that the patient's surrounding joint segments would accommodate any additional articulation demanded of them during normal motion by virtue of the fused segment's immobility. While this is true over the short-term (provided only one, or at most two, segments have been fused), the effects of this increased range of articulation demanded of these adjacent segments has recently become a concern. Specifically, an increase in the frequency of returning patients who suffer from degeneration at adjacent levels has been reported.

Whether this increase in adjacent level deterioration is truly associated with rigid fusion, or if it is simply a matter of the individual patient's predisposition to degeneration is unknown. Either way, however, it is clear that a progressive fusion of a long sequence of vertebrae is undesirable from the perspective of the patient's quality of life as well as from the

perspective of pushing a patient to undergo multiple operative procedures.

While spine arthroplasty has been developing in theory over the past several decades, and has even seen a number of early
5 attempts in the lumbar spine show promising results, it is only recently that arthroplasty of the spine has become a truly realizable promise. The field of spine arthroplasty has several classes of devices. The most popular among these are: (a) the
10 nucleus replacements, which are characterized by a flexible container filled with an elastomeric material that can mimic the healthy nucleus; and (b) the total disc replacements, which are designed with rigid endplates which house a mechanical articulating structure that attempts to mimic and promote the healthy segmental motion.

15 Among these solutions, the total disc replacements have begun to be regarded as the most probable long-term treatments for patients having moderate to severe lumbar disc degeneration. In the cervical spine, it is likely that these mechanical solutions will also become the treatment of choice.

20 It is an object of the invention to provide instrumentation and methods that enable surgeons to more accurately, easily, and efficiently implant fusion or non-fusion cervical disc replacement devices. Other objects of the invention not explicitly stated will be set forth and will be more clearly
25 understood in conjunction with the descriptions of the preferred embodiments disclosed hereafter.

Summary Of The Invention

The preceding objects are achieved by the invention, which includes cervical disc replacement trials, cervical disc
30 replacement devices, cervical disc replacement device insertion instrumentation (including, e.g., an insertion plate with mounting screws, an insertion handle, and an insertion pusher), and cervical disc replacement device fixation instrumentation (including, e.g., drill guides, drill bits, screwdrivers, bone
35 screws, and retaining clips).

More particularly, the devices, instrumentation, and methods disclosed herein are intended for use in spine arthroplasty

procedures, and specifically for use with the devices, instrumentation, and methods described herein in conjunction with the devices, instrumentation, and methods described herein and in the `702 application. However, it should be understood that the devices, instrumentation, and methods described herein are also suitable for use with other intervertebral disc replacement devices, instrumentation, and methods without departing from the scope of the invention.

For example, while the trials described herein are primarily intended for use in distracting an intervertebral space and/or determining the appropriate size of cervical disc replacement devices (e.g., described herein and in the `702 application) to be implanted (or whether a particular size can be implanted) into the distracted intervertebral space, they can also be used for determining the appropriate size of any other suitably configured orthopedic implant or trial to be implanted (or whether a particular size can be implanted) into the distracted intervertebral space. And, for example, while the insertion instrumentation described herein is primarily intended for use in holding, inserting, and otherwise manipulating cervical disc replacement devices (e.g., described herein and, in suitably configured embodiments, in the `702 application), it can also be used for manipulating any other suitably configured orthopedic implant or trial. And, for example, while the fixation instrumentation described herein is primarily intended for use in securing within the intervertebral space the cervical disc replacement devices (e.g., described herein and, in suitably configured embodiments, in the `702 application), it can also be used with any other suitably configured orthopedic implant or trial.

While the instrumentation described herein (e.g., the trials, insertion instrumentation, and fixation instrumentation) will be discussed for use with the cervical disc replacement device of Figs. 1a-3f herein, such discussions are merely by way of example and not intended to be limiting of their uses. Thus, it should be understood that the tools can be used with suitably configured embodiments of the cervical disc replacement devices

disclosed in the '702 application, or any other artificial intervertebral disc having (or being modifiable or modified to have) suitable features therefor. Moreover, it is anticipated that the features of the cervical disc replacement device (e.g., the flanges, bone screw holes, and mounting holes) that are used by the tools discussed herein to hold and/or manipulate these devices (some of such features, it should be noted, were first shown and disclosed in the '702 application) can be applied, individually or collectively or in various combinations, to other trials, spacers, artificial intervertebral discs, or other orthopedic devices as stand-alone innovative features for enabling such trials, spacers, artificial intervertebral discs, or other orthopedic devices to be more efficiently and more effectively held and/or manipulated by the tools described herein or by other tools having suitable features. In addition, it should be understood that the invention encompasses artificial intervertebral discs, spacers, trials, and/or other orthopedic devices, that have one or more of the features disclosed herein, in any combination, and that the invention is therefore not limited to artificial intervertebral discs, spacers, trials, and/or other orthopedic devices having all of the features simultaneously.

The cervical disc replacement device of Figs. 1a-3f is an alternate embodiment of the cervical disc replacement device of the '702 application. The illustrated alternate embodiment of the cervical disc replacement device is identical in structure to the cervical disc replacement device in the '702 application, with the exception that the vertebral bone attachment flanges are configured differently, such that they are suitable for engagement by the instrumentation described herein.

More particularly, in this alternate embodiment, the flange of the upper element extends upwardly from the anterior edge of the upper element, and has a lateral curvature that approximates the curvature of the anterior periphery of the upper vertebral body against which it is to be secured. The attachment flange is provided with a flat recess, centered on the midline, that accommodates a clip of the present invention. The attachment

flange is further provided with two bone screw holes symmetrically disposed on either side of the midline. The holes have longitudinal axes directed along preferred bone screw driving lines. Centrally between the bone screw holes, a mounting screw hole is provided for attaching the upper element to an insertion plate of the present invention for implantation. The lower element is similarly configured with a similar oppositely extending flange.

Once the surgeon has prepared the intervertebral space, the surgeon may use one or more cervical disc replacement trials of the present invention to distract the intervertebral space and determine the appropriate size of a cervical disc replacement device to be implanted (or whether a particular size of the cervical disc replacement device can be implanted) into the distracted cervical intervertebral space. Preferably, for each cervical disc replacement device to be implanted, a plurality of sizes of the cervical disc replacement device would be available. Accordingly, preferably, each of the plurality of trials for use with a particular plurality of differently sized cervical disc replacement devices would have a respective oval footprint and depth dimension set corresponding to the footprint and depth dimension set of a respective one of the plurality of differently sized cervical disc replacement devices.

Each of the cervical disc replacement trials includes a distal end configured to approximate relevant dimensions of an available cervical disc replacement device. The distal end has a head with an oval footprint. The upper surface of the head is convex, similar to the configuration of the vertebral body contact surface of the upper element of the cervical disc replacement device (but without the teeth). The lower surface of the head is flat, similar to the configuration of the vertebral body contact surface of the lower element of the cervical disc replacement device (but without the teeth). The cervical disc replacement trial, not having the teeth, can be inserted and removed from the intervertebral space without compromising the endplate surfaces. The cervical disc replacement trial further has a vertebral body stop disposed at the anterior edge of the

head, to engage the anterior surface of the upper vertebral body before the trial is inserted too far into the intervertebral space.

Accordingly, the surgeon can insert and remove at least one
5 of the trials (or more, as necessary) from the prepared intervertebral space. As noted above, the trials are useful for distracting the prepared intervertebral space. For example, starting with the largest distractor that can be wedged in between the vertebral bones, the surgeon will insert the trial
10 head and then lever the trial handle up and down to loosen the annulus and surrounding ligaments to urge the bone farther apart.

The surgeon then removes the trial head from the intervertebral space, and replaces it with the next largest (in terms of height) trial head. The surgeon then levers the trial handle up and down
15 to further loosen the annulus and ligaments. The surgeon then proceeds to remove and replace the trial head with the next largest (in terms of height) trial head, and continues in this manner with larger and larger trials until the intervertebral space is distracted to the appropriate height.

Regardless of the distraction method used, the cervical disc
20 replacement trials are useful for finding the cervical disc replacement device size that is most appropriate for the prepared intervertebral space, because each of the trial heads approximates the relevant dimensions of an available cervical
25 disc replacement device. Once the intervertebral space is distracted, the surgeon can insert and remove one or more of the trial heads to determine the appropriate size of cervical disc replacement device to use. Once the appropriate size is determined, the surgeon proceeds to implant the selected cervical
30 disc replacement device.

An insertion plate of the present invention is mounted to the cervical disc replacement device to facilitate a preferred simultaneous implantation of the upper and lower elements of the replacement device. The upper and lower elements are held by the
35 insertion plate in an aligned configuration preferable for implantation. A ledge on the plate maintains a separation between the anterior portions of the inwardly facing surfaces of

the elements to help establish and maintain this preferred relationship. The flanges of the elements each have a mounting screw hole and the insertion plate has two corresponding mounting holes. Mounting screws are secured through the colinear mounting screw hole pairs, such that the elements are immovable with respect to the insertion plate and with respect to one another. In this configuration, the upper element, lower element, and insertion plate construct is manipulatable as a single unit.

An insertion handle of the present invention is provided primarily for engaging an anteriorly extending stem of the insertion plate so that the cervical disc replacement device and insertion plate construct can be manipulated into and within the treatment site. The insertion handle has a shaft with a longitudinal bore at a distal end and a flange at a proximal end.

Longitudinally aligning the insertion handle shaft with the stem, and thereafter pushing the hollow distal end of the insertion handle shaft toward the insertion plate, causes the hollow distal end to friction-lock to the outer surface of the stem. Once the insertion handle is engaged with the insertion plate, manipulation of the insertion handle shaft effects manipulation of the cervical disc replacement device and insertion plate construct. The surgeon can therefore insert the construct into the treatment area. More particularly, after the surgeon properly prepares the intervertebral space, the surgeon inserts the cervical disc replacement device into the intervertebral space from an anterior approach, such that the upper and lower elements are inserted between the adjacent vertebral bones with the element footprints fitting within the perimeter of the intervertebral space and with the teeth of the elements' vertebral body contact surfaces engaging the vertebral endplates, and with the flanges of the upper and lower elements flush against the anterior faces of the upper and lower vertebral bones, respectively.

Once the construct is properly positioned in the treatment area, the surgeon uses an insertion pusher of the present invention to disengage the insertion handle shaft from the stem of the insertion plate. The insertion pusher has a longitudinal

shaft with a blunt distal end and a proximal end with a flange. The shaft of the insertion pusher can be inserted into and translated within the longitudinal bore of the insertion handle shaft. Because the shaft of the insertion pusher is as long as
5 the longitudinal bore of the insertion handle shaft, the flange of the insertion handle and the flange of the insertion pusher are separated by a distance when the pusher shaft is inserted all the way into the longitudinal bore until the blunt distal end of the shaft contacts the proximal face of the insertion plate stem.
10 Accordingly, a bringing together of the flanges (e.g., by the surgeon squeezing the flanges toward one another) will overcome the friction lock between the distal end of the insertion handle shaft and the stem of the insertion plate.

Once the insertion handle has been removed, the surgeon uses
15 a drill guide of the present invention to guide the surgeon's drilling of bone screws through the bone screw holes of the upper and lower elements' flanges and into the vertebral bones. The drill guide has a longitudinal shaft with a distal end configured with a central bore that accommodates the stem so that the drill
20 guide can be placed on and aligned with the stem. The distal end is further configured to have two guide bores that have respective longitudinal axes at preferred bone screw drilling paths relative to one another. When the central bore is disposed on the stem of the insertion plate, the drill guide shaft can be
25 rotated on the stem into either of two preferred positions in which the guide bores are aligned with the bone screw holes on one of the flanges, or with the bone screw holes on the other flange.

To secure the upper element flange to the upper vertebral
30 body, the surgeon places the drill guide shaft onto the stem of the insertion plate, and rotates the drill guide into the first preferred position. Using a suitable bone drill and cooperating drill bit, the surgeon drills upper tap holes for the upper bone screws. The surgeon then rotates the drill guide shaft on the
35 stem of the insertion plate until the guide bores no longer cover the upper bone screw holes. The surgeon can then screw the upper bone screws into the upper tap holes using a suitable surgical

bone screw driver. To then secure the lower element flange to the lower vertebral body, the surgeon further rotates the drill guide shaft on the stem of the insertion plate until the drill guide is in the second preferred position, and proceeds to drill the lower bone screw tap holes and screw the lower bone screws into them in the same manner.

Once the upper and lower elements are secured to the adjacent vertebral bones, the surgeon removes the drill guide from the stem of the insertion plate and from the treatment area.

Using a suitable surgical screw driver, the surgeon then removes the mounting screws that hold the insertion plate against the elements' flanges and removes the insertion plate and the mounting screws from the treatment area.

Once the mounting screws and the insertion plate are removed, the surgeon uses a clip applicator of the present invention to mount retaining clips on the flanges to assist in retaining the bone screws. Each of the clips has a central attachment bore and, extending therefrom, a pair of oppositely directed laterally extending flanges and an upwardly (or downwardly) extending hooked flange. The clips can be snapped onto the element flanges (one clip onto each flange). Each of the laterally extending flanges of the clip is sized to cover at least a portion of a respective one of the bone screw heads when the clip is attached in this manner to the flange so that the clips help prevent the bone screws from backing out. In an alternate embodiment, the retaining device comprises a threaded member and a head flange member, the threaded member received into the threaded opening of the mounting screw holes left by the removal of the mounting screws and the insertion plate.

Also disclosed is an alternate dual cervical disc replacement device configuration suitable, for example, for implantation into two adjacent cervical intervertebral spaces. The configuration includes an alternate, upper, cervical disc replacement device (including an upper element and an alternate lower element), for implantation into an upper cervical intervertebral space, and further includes an alternate, lower, cervical disc replacement device (including an alternate upper

element and a lower element), for implantation into an adjacent, lower, cervical intervertebral space. The illustrated alternate, upper, embodiment is identical in structure to the cervical disc replacement device of Figs. 1a-3f, with the exception that the flange of the lower element is configured differently and without bone screw holes. The illustrated alternate, lower, embodiment is identical in structure to the cervical disc replacement device of Figs. 1a-3f, with the exception that the flange of the upper element is configured differently and without bone screw holes.

More particularly, in the alternate, upper, cervical disc replacement device of this alternate configuration, the flange of the alternate lower element does not have bone screw holes, but does have a mounting screw hole for attaching the alternate lower element to an alternate, upper, insertion plate. Similarly, in the alternate, lower, cervical disc replacement device of this alternate configuration, the flange of the alternate upper element does not have bone screw holes, but does have a mounting screw hole for attaching the alternate upper element to an alternate, lower, insertion plate. The extent of the flange of the alternate lower element is laterally offset to the right (in an anterior view) from the midline, and the extent of the flange of the alternate upper element is laterally offset to the left (in an anterior view) from the midline, so that the flanges avoid one another when the alternate lower element of the alternate, upper, cervical disc replacement device, and the alternate upper element of the alternate, lower, cervical disc replacement device, are implanted in this alternate configuration.

The alternate, upper, insertion plate is identical in structure to the insertion plate described above, with the exception that the lower flange is offset from the midline (to the right in an anterior view) to align its mounting screw hole with the offset mounting screw hole of the alternate lower element. Similarly, the alternate, lower, insertion plate is identical in structure to the insertion plate described above, with the exception that the upper flange is offset from the midline (to the left in an anterior view) to align its mounting screw hole with the offset mounting screw hole of the alternate

upper element.

Accordingly, the upper and lower elements of the alternate, upper, cervical disc replacement device, being held by the alternate upper insertion plate, as well as the upper and lower
5 elements of the alternate, lower, cervical disc replacement device, being held by the alternate lower insertion plate, can be implanted using the insertion handle, insertion pusher, drill guide, clips (one on the uppermost element flange, and one on the
10 the lowermost element are secured by bone screws), and clip applicator, in the manner described above with respect to the implantation of the cervical disc replacement device.

Brief Description Of The Drawings

15 Figs. 1a-c show anterior (Fig. 1a), lateral (Fig. 1b), and bottom (Fig. 1c) views of a top element of a cervical disc replacement device of the invention.

Figs. 2a-c show anterior (Fig. 2a), lateral (Fig. 2b), and top (Fig. 2c) views of a bottom element of the cervical disc replacement device.

20 Fig. 3a-f show top (Fig. 3a), lateral (Fig. 3b), anterior (Fig. 3c), posterior (Fig. 3d), antero-lateral perspective (Fig. 3e), and postero-lateral perspective (Fig. 3f) views of the cervical disc replacement device, assembled with the top and bottom elements of Figs. 1a-c and 2a-c.

25 Figs. 4a-g show top (Fig. 4a), lateral (Fig. 4b), anterior (Fig. 4c), posterior (Fig. 4d), antero-lateral perspective (head only) (Fig. 4e), and postero-lateral perspective (head only) (Fig. 4f) views of a cervical disc replacement trial of the present invention.

30 Figs. 5a-d show top (Fig. 5a), lateral (Fig. 5b), anterior (Fig. 5c), and posterior (Fig. 5d) views of an insertion plate of the insertion instrumentation of the present invention. Figs. 5e and 5f show anterior (Fig. 5e) and antero-lateral perspective (Fig. 5f) views of the insertion plate mounted to the cervical
35 disc replacement device.

Figs. 6a-d show top (Fig. 6a), lateral (Fig. 6b), anterior (Fig. 6c), and postero-lateral (Fig. 6d) views of an insertion

handle of the insertion instrumentation of the present invention. Fig. 6e shows an antero-lateral perspective view of the insertion handle attached to the insertion plate. Fig. 6f shows a magnified view of the distal end of Fig. 6e.

5 Figs. 7a-c show top (Fig. 7a), lateral (Fig. 7b), and anterior (Fig. 7c) views of an insertion pusher of the insertion instrumentation of the present invention. Fig. 7d shows an antero-lateral perspective view of the insertion pusher inserted into the insertion handle. Fig. 7e shows a magnified view of the
10 proximal end of Fig. 7d.

Figs. 8a-c show top (Fig. 8a), lateral (Fig. 8b), and anterior (Fig. 8c) views of a drill guide of the insertion instrumentation of the present invention. Fig. 8d shows an antero-lateral perspective view of the drill guide inserted onto
15 the insertion plate. Fig. 8e shows a magnified view of the distal end of Fig. 8d.

Fig. 9a shows an antero-lateral perspective view of the cervical disc replacement device implantation after bone screws have been applied and before the insertion plate has been removed. Fig. 9b shows an antero-lateral perspective view of the
20 cervical disc replacement device after bone screws have been applied and after the insertion plate has been removed.

Figs. 10a-f show top (Fig. 10a), lateral (Fig. 10b), posterior (Fig. 10c), anterior (Fig. 10d), postero-lateral (Fig. 10e), and antero-lateral (Fig. 10f) views of a retaining clip of
25 the present invention.

Figs. 11a-c show top (Fig. 11a), lateral (Fig. 11b), and anterior (Fig. 11c) views of a clip applicator of the insertion instrumentation of the present invention. Fig. 11d shows a
30 postero-lateral perspective view of the clip applicator holding two retaining clips. Fig. 11e shows an antero-lateral perspective view of Fig. 11d.

Fig. 12a shows the clip applicator applying the retaining clips to the cervical disc replacement device. Figs. 12b-h show
35 anterior (Fig. 12b), posterior (Fig. 12c), top (Fig. 12d), bottom (Fig. 12e), lateral (Fig. 12f), antero-lateral perspective (Fig. 12g), and postero-lateral perspective (Fig. 12h) views of the

cervical disc replacement device after the retaining clips have been applied.

Figs. 13a-b show a prior art one level cervical fusion plate in anterior (Fig. 13a) and lateral (Fig. 13b) views. Figs. 13c-d
5 show a prior art two level cervical fusion plate in anterior (Fig. 13c) and lateral (Fig. 13d) views.

Figs. 14a-e show an alternate, dual cervical disc replacement device configuration and alternate insertion plates for use therewith, in exploded perspective (Fig. 14a), anterior
10 (Fig. 14b), posterior (Fig. 14c), lateral (Fig. 14d), and collapsed perspective (Fig. 14e) views.

Figs. 15a-c show an alternate upper element of the configuration of Figs. 14a-e, in posterior (Fig. 15a), anterior (Fig. 15b), and antero-lateral (Fig. 15c) views.

15 Figs. 16a-c show an alternate lower element of the configuration of Figs. 14a-e, in posterior (Fig. 16a), anterior (Fig. 16b), and antero-lateral (Fig. 16c) views.

Figs. 17a-c show an alternate, upper, insertion plate of the configuration of Figs. 14a-e in anterior (Fig. 17a), posterior
20 (Fig. 17b), and antero-lateral (Fig. 17c) views.

Figs. 18a-c show an alternate, lower, insertion plate of the configuration of Figs. 14a-e in anterior (Fig. 18a), posterior (Fig. 18b), and antero-lateral (Fig. 18c) views.

Figs. 19a-c show an alternate retaining device for the bone
25 screws in antero-lateral perspective partial assembly (Fig. 19a), top assembly (Fig. 19b) and top (Fig. 19c) views.

Best Mode of Carrying Out the Invention

While the invention will be described more fully hereinafter with reference to the accompanying drawings, it is to be
30 understood at the outset that persons skilled in the art may modify the invention herein described while achieving the functions and results of the invention. Accordingly, the descriptions that follow are to be understood as illustrative and exemplary of specific structures, aspects and features within the
35 broad scope of the invention and not as limiting of such broad scope. Like numbers refer to similar features of like elements throughout.

A preferred embodiment of a cervical disc replacement device of the present invention, for use with the instrumentation of the present invention, will now be described.

Referring now to Figs. 1a-3f, a top element 500 of the cervical disc replacement device 400 is shown in anterior (Fig. 1a), lateral (Fig. 1b), and bottom (Fig. 1c) views; a bottom element 600 of the cervical disc replacement device 400 is shown in anterior (Fig. 2a), lateral (Fig. 2b), and top (Fig. 2c) views; and an assembly 400 of the top and bottom elements 500,600 is shown in top (Fig. 3a), lateral (Fig. 3b), anterior (Fig. 3c), posterior (Fig. 3d), antero-lateral perspective (Fig. 3e), and postero-lateral perspective (Fig. 3f) views.

The cervical disc replacement device 400 is an alternate embodiment of the cervical disc replacement device of the `702 application. The illustrated alternate embodiment of the cervical disc replacement device is identical in structure to the cervical disc replacement device 100 in the `702 application (and thus like components are like numbered, but in the 400s rather than the 100s, in the 500s rather than the 200s, and in the 600s rather than the 300s), with the exception that the vertebral bone attachment flanges are configured differently, such that they are suitable for engagement by the instrumentation described herein.

(It should be noted that, while the `702 application illustrated and described the cervical disc replacement device 100 as having an upper element flange 506 with two bone screw holes 508a,508b, and a lower element flange 606 with one bone screw hole 608, the `702 application explained that the number of holes and the configuration of the flanges could be modified without departing from the scope of the invention as described in the `702 application.)

More particularly, in this alternate embodiment, the upper element 500 of the cervical disc replacement device 400 has a vertebral body attachment structure (e.g., a flange) 506 that preferably extends upwardly from the anterior edge of the upper element 500, and preferably has a lateral curvature that approximates the curvature of the anterior periphery of the upper vertebral body against which it is to be secured. The attachment

flange 506 is preferably provided with a flat recess 507, centered on the midline, that accommodates a clip 1150a (described below) of the present invention. The attachment flange 506 is further provided with at least one (e.g., two) bone screw holes 508a,508b, preferably symmetrically disposed on either side of the midline. Preferably, the holes 508a,508b have longitudinal axes directed along preferred bone screw driving lines. For example, in this alternate embodiment, the preferred bone screw driving lines are angled upwardly at 5 degrees and inwardly (toward one another) at 7 degrees (a total of 14 degrees of convergence), to facilitate a toenailing of the bone screws (described below and shown in Figs. 12a-h). Centrally between the bone screw holes 508a,508b, at least one mounting feature (e.g., a mounting screw hole) 509 is provided for attaching the upper element 500 to an insertion plate 700 (described below) for implantation.

Similarly, in this alternate embodiment, the lower element 600 of the cervical disc replacement device 400 also has a vertebral body attachment structure (e.g., an oppositely directed and similarly configured vertebral body attachment flange) 606 that preferably extends downwardly from the anterior edge of the lower element 600, and preferably has a lateral curvature that approximates the curvature of the anterior periphery of the lower vertebral body against which it is to be secured. The attachment flange 606 is preferably provided with a flat recess 607, centered on the midline, that accommodates a clip 1150b (described below) of the present invention. The attachment flange 606 is further provided with at least one (e.g., two) bone screw holes 608a,608b, preferably symmetrically disposed on either side of the midline. Preferably, the holes 608a,608b have longitudinal axes directed along preferred bone screw driving lines. For example, in this alternate embodiment, the preferred bone screw driving lines are angled downwardly at 5 degrees and inwardly (toward one another) at 7 degrees (a total of 14 degrees of convergence), to facilitate a toenailing of the bone screws (described below and shown in Figs. 12a-h). Centrally between the bone screw holes 608a,608b, at least one mounting feature

(e.g., a mounting screw hole) 609 is provided for attaching the lower element 600 to the insertion plate 700 (described below) for implantation.

Prior to implantation of the cervical disc replacement device, the surgeon will prepare the intervertebral space. Typically, this will involve establishing access to the treatment site, removing the damaged natural intervertebral disc, preparing the surfaces of the endplates of the vertebral bones adjacent the intervertebral space, and distracting the intervertebral space. (It should be noted that the cervical disc replacement device of the present invention, and the instrumentation and implantation methods described herein, require minimal if any endplate preparation.) More particularly, after establishing access to the treatment site, the surgeon will remove the natural disc material, preferably leaving as much as possible of the annulus intact. Then, the surgeon will remove the anterior osteophyte that overhangs the mouth of the cervical intervertebral space, and any lateral osteophytes that may interfere with the placement of the cervical disc replacement device or the movement of the joint. Using a burr tool, the surgeon will then ensure that the natural lateral curvature of the anterior faces of the vertebral bodies is uniform, by removing any surface anomalies that deviate from the curvature. Also using the burr tool, the surgeon will ensure that the natural curvature of the endplate surface of the upper vertebral body, and the natural flatness of the endplate surface of the lower vertebral body, are uniform, by removing any surface anomalies that deviate from the curvature or the flatness. Thereafter, the surgeon will distract the intervertebral space to the appropriate height for receiving the cervical disc replacement device. Any distraction tool or method known in the art, e.g., a Caspar Distractor, can be used to effect the distraction and/or hold open the intervertebral space. Additionally or alternatively, the cervical disc replacement trials of the present invention can be used to distract the intervertebral space (as described below).

Referring now to Figs. 4a-f, a cervical disc replacement trial 1200 of the present invention is shown in top (Fig. 4a),

lateral (Fig. 4b), lateral (head only) (Fig. 4c), posterior (Fig. 4d), anterior (Fig. 4e), antero-lateral perspective (head only) (Fig. 4f), and postero-lateral perspective (head only) (Fig. 4g) views.

5 Preferably, a plurality of cervical disc replacement trials are provided primarily for use in determining the appropriate size of a cervical disc replacement device to be implanted (or whether a particular size of the cervical disc replacement device can be implanted) into the distracted cervical intervertebral
10 space (e.g., the cervical disc replacement device 400 of Figs. 1a-3f). Preferably, for each cervical disc replacement device to be implanted, a plurality of sizes of the cervical disc replacement device would be available. That is, preferably, a plurality of the same type of cervical disc replacement device
15 would be available, each of the plurality having a respective footprint and depth dimension combination that allows it to fit within a correspondingly dimensioned intervertebral space. For example, the plurality of cervical disc replacement devices could include cervical disc replacement devices having oval footprints
20 being 12mm by 14mm, 14mm by 16mm, or 16mm by 18mm, and depths ranging from 6mm to 14mm in 1mm increments, for a total of 27 devices. Accordingly, preferably, each of the plurality of trials for use with a particular plurality of differently sized cervical disc replacement devices would have a respective oval
25 footprint and depth dimension set corresponding to the footprint and depth dimension set of a respective one of the plurality of differently sized cervical disc replacement devices. For example, the plurality of trials for use with the set of cervical disc replacement devices described, for example, could include
30 trials having oval footprints being 12mm by 14mm, 14mm by 16mm, or 16mm by 18mm, and depths ranging from 6mm to 14mm in 1mm increments, for a total of 27 static trials. It should be understood that the cervical disc replacement devices and/or the trials can be offered in a variety of dimensions without
35 departing from the scope of the invention, and that the dimensions specifically identified and quantified herein are merely exemplary. Moreover, it should be understood that the set

of trials need not include the same number of trials for each cervical disc replacement device in the set of cervical disc replacement devices, but rather, none, one, or more than one trial can be included in the trial set for any particular cervical disc replacement device in the set.

Each of the cervical disc replacement trials (the cervical disc replacement trial 1200 shown in Figs. 4a-g is exemplary for all of the trials in the plurality of trials; preferably the trials in the plurality of trials differ from one another only with regard to certain dimensions as described above) includes a shaft 1202 having a configured distal end 1204 and a proximal end having a handle 1206. Preferably, the proximal end is provided with a manipulation features (e.g., a hole 1216) to, e.g., decrease the weight of the trial 1200, facilitate manipulation of the trial 1200, and provide a feature for engagement by an instrument tray protrusion. The distal end is configured to approximate relevant dimensions of the cervical disc replacement device. More particularly in the illustrated embodiment (for example), the distal end 1204 has a trial configuration (e.g., a head 1208 having an oval footprint dimensioned at 12mm by 14mm, and a thickness of 6mm). The upper surface 1210 of the head 1208 is convex, similar to the configuration of the vertebral body contact surface of the upper element 500 of the cervical disc replacement device 400 (but without the teeth). The lower surface 1212 of the head 1208 is flat, similar to the configuration of the vertebral body contact surface of the lower element 600 of the cervical disc replacement device 400 (but without the teeth). The illustrated embodiment, therefore, with these dimensions, approximates the size of a cervical disc replacement device having the same height and footprint dimensions. The cervical disc replacement trial, not having the teeth, can be inserted and removed from the intervertebral space without compromising the endplate surfaces. The cervical disc replacement trial 1200 further has an over-insertion prevention features (e.g., a vertebral body stop 1214) preferably disposed at the anterior edge of the head 1208, to engage the anterior surface of the upper vertebral body before the trial 1200 is

inserted too far into the intervertebral space. The body of the trial 1200 preferably has one or more structural support features (e.g., a rib 1216 extending anteriorly from the head 1208 below the shaft 1202) that provides stability, e.g., to the shaft 1202 for upward and downward movement, e.g., if the head 1208 must be urged into the intervertebral space by moving the shaft 1202 in this manner. Further, preferably as shown, the head 1208 is provided with an insertion facilitation features (e.g., a taper, decreasing posteriorly) to facilitate insertion of the head 1208 into the intervertebral space by, e.g., acting as a wedge to urge the vertebral endplates apart. Preferably, as shown, the upper surface 1210 is fully tapered at approximately 5 degrees, and the distal half of the lower surface 1212 is tapered at approximately 4 degrees.

Accordingly, the surgeon can insert and remove at least one of the trials (or more, as necessary) from the prepared intervertebral space. As noted above, the trials are useful for distracting the prepared intervertebral space. For example, starting with the largest distractor that can be wedged in between the vertebral bones, the surgeon will insert the trial head 1208 (the tapering of the trial head 1208 facilitates this insertion by acting as a wedge to urge the vertebral endplates apart), and then lever the trial handle 1206 up and down to loosen the annulus and surrounding ligaments to urge the bone farther apart. Once the annulus and ligaments have been loosened, the surgeon removes the trial head 1208 from the intervertebral space, and replaces it with the next largest (in terms of height) trial head 1208. The surgeon then levers the trial handle 1206 up and down to further loosen the annulus and ligaments. The surgeon then proceeds to remove and replace the trial head 1208 with the next largest (in terms of height) trial head 1208, and continues in this manner with larger and larger trials until the intervertebral space is distracted to the appropriate height. This gradual distraction method causes the distracted intervertebral space to remain at the distracted height with minimal subsidence before the cervical disc replacement device is implanted. The appropriate height is one

that maximizes the height of the intervertebral space while preserving the annulus and ligaments.

Regardless of the distraction method used, the cervical disc replacement trials are useful for finding the cervical disc replacement device size that is most appropriate for the prepared intervertebral space, because each of the trial heads approximates the relevant dimensions of an available cervical disc replacement device. Once the intervertebral space is distracted, the surgeon can insert and remove one or more of the trial heads to determine the appropriate size of cervical disc replacement device to use. Once the appropriate size is determined, the surgeon proceeds to implant the selected cervical disc replacement device.

A preferred method of, and instruments for use in, implanting the cervical disc replacement device will now be described.

Referring now to Figs. 5a-f, an insertion plate 700 of the insertion instrumentation of the present invention is shown in top (Fig. 5a), lateral (Fig. 5b), anterior (Fig. 5c), and posterior (Fig. 5d) views. Figs. 5e and 5f show anterior (Fig. 5e) and antero-lateral perspective (Fig. 5f) views of the insertion plate 700 mounted to the cervical disc replacement device 400.

The insertion plate 700 has a base 702 with a first mounting area 704a (preferably an upwardly extending flange) and a second mounting area 704b (preferably a downwardly extending flange), and a primary attachment feature (e.g., an anteriorly extending central stem) 706. The connection of the stem 706 to the base 702 preferably includes an axial rotation prevention feature, e.g., two oppositely and laterally extending key flanges 708a, 708b. The stem 706 preferably has a proximal portion 710 that is tapered to have a decreasing diameter away from the base 702. That is, the tapered proximal portion 710 has an initial smaller diameter that increases toward the base 702 gradually to a final larger diameter. The base 702 preferably has a posteriorly extending ledge 716 that has a flat upper surface and a curved lower surface.

The insertion plate 700 is mounted to the cervical disc replacement device 400 to facilitate the preferred simultaneous implantation of the upper and lower elements 500,600. The upper and lower elements 500,600 are held by the insertion plate 700 in a preferred relationship to one another that is suitable for implantation. More particularly, as shown in Figs. 3a-f, 5e, and 5f, the elements 500,600 are preferably axially rotationally aligned with one another, with the element perimeters and flanges 506,606 axially aligned with one another, and held with the bearing surfaces 512,612 in contact. The ledge 716 maintains a separation between the anterior portions of the inwardly facing surfaces of the elements 500,600 to help establish and maintain this preferred relationship, with the flat upper surface of the ledge 716 in contact with the flat anterior portion of the inwardly facing surface of the upper element 500, and the curved lower surface of the ledge 716 in contact with the curved anterior portion of the inwardly facing surface of the lower element 600.

While any suitable method or mechanism can be used to mount the elements 500,600 to the insertion plate 700, a preferred arrangement is described. That is, it is preferred, as shown and as noted above, that the flanges 506,606 of the elements 500,600 (in addition to having the bone screw holes 508a,508b,608a,608b described above) each have at least one mounting feature (e.g., mounting screw hole 509,609), and the insertion plate 700 has two (at least two, each one alignable with a respective mounting screw hole 509,609) corresponding mounting features (e.g., mounting screw holes 712a,712b), spaced to match the spacing of (and each be colinear with a respective one of) the mounting screw holes 509,609 on the flanges 506,606 of the elements 500,600 of the cervical disc replacement device 400 when those elements 500,600 are disposed in the preferred relationship for implantation. Accordingly, mounting screws 714a,714b or other suitable fixation devices are secured through the colinear mounting screw hole pairs 509,712a and 609,712b (one screw through each pair), such that the elements 500,600 are immovable with respect to the insertion plate 700 and with respect to one

another. Thus, in this configuration, the upper element 500, lower element 600, and insertion plate 700 construct is manipulatable as a single unit.

Preferably, for each size of cervical disc replacement device, the described configuration is established (and rendered sterile in a blister pack through methods known in the art) prior to delivery to the surgeon. That is, as described below, the surgeon will simply need to open the blister pack and apply the additional implantation tools to the construct in order to implant the cervical disc replacement device. Preferably, the configuration or dimensions of the insertion plate can be modified (either by providing multiple different insertion plates, or providing a single dynamically modifiable insertion plate) to accommodate cervical disc replacement devices of varying heights. For example, the positions of the mounting screw holes 712a,712b on the flanges 704a,704b can be adjusted (e.g., farther apart for replacement devices of greater height, and close together for replacement devices of lesser height), and the size of the flanges 704a,70b can be adjusted to provide structural stability for the new hole positions. Preferably, in other respects, the insertion plate configuration and dimensions need not be modified, to facilitate ease of manufacturing and lower manufacturing costs.

It should be noted that the described configuration of the construct presents the cervical disc replacement device to the surgeon in a familiar manner. That is, by way of explanation, current cervical fusion surgery involves placing a fusion device (e.g., bone or a porous cage) in between the cervical intervertebral bones, and attaching a cervical fusion plate to the anterior aspects of the bones. Widely used cervical fusion devices (an example single level fusion plate 1300 is shown in anterior view in Fig. 13a and in lateral view in Fig. 13b) are configured with a pair of laterally spaced bone screw holes 1302a,1302b on an upper end 1304 of the plate 1300, and a pair of laterally spaced bone screw holes 1306a,1306b on a lower end 1308 of the plate 1300. To attach the plate 1300 to the bones, two bone screws are disposed through the upper end's bone screw holes

1302a,1302b and into the upper bone, and two bone screws are disposed through the lower end's bone screw holes 1306a,1306b and into the lower bone. This prevents the bones from moving relative to one another, and allows the bones to fuse to one another with the aid of the fusion device.

Accordingly, as can be seen in Fig. 5e, when the upper and lower elements 500,600 of the cervical disc replacement device 400 are held in the preferred spatial relationship, the flanges 506,606 of the elements 500,600, and their bone screw holes 508a,508b, present to the surgeon a cervical hardware and bone screw hole configuration similar to a familiar cervical fusion plate configuration. The mounting of the elements 500,600 to the insertion plate 700 allows the elements 500,600 to be manipulated as a single unit for implantation (by manipulating the insertion plate 700), similar to the way a cervical fusion plate is manipulatable as a single unit for attachment to the bones. This aspect of the present invention simplifies and streamlines the cervical disc replacement device implantation procedure.

As noted above, the cervical disc replacement device 400 and insertion plate 700 construct is preferably provided sterile (e.g., in a blister pack) to the surgeon in an implant tray (the tray preferably being filled with constructs for each size of cervical disc replacement device). The construct is preferably situated in the implant tray with the stem 706 of the insertion plate 700 facing upwards for ready acceptance of the insertion handle 800 (described below).

Referring now to Figs. 6a-e, an insertion handle 800 of the insertion instrumentation of the present invention is shown in top (Fig. 6a), lateral (Fig. 6b), anterior (Fig. 6c), and postero-lateral (distal end only) (Fig. 6d) views. Fig. 6e shows an antero-lateral perspective view of the insertion handle 800 attached to the stem 706 of the insertion plate 700. Fig. 6f shows a magnified view of the distal end of Fig. 6e.

The insertion handle 800 is provided primarily for engaging the stem 706 of the insertion plate 700 so that the cervical disc replacement device 400 and insertion plate 700 construct can be manipulated into and within the treatment site. The insertion

handle 800 has a shaft 802 with an attachment feature (e.g., a longitudinal bore) 804 at a distal end 806 and a manipulation feature (e.g., a flange) 810 at a proximal end 808. Preferably, the longitudinal bore 804 has an inner taper at the distal end 5 806 such that the inner diameter of the distal end 806 decreases toward the distal end 806, from an initial larger inner diameter at a proximal portion of the distal end 806 to a final smaller inner diameter at the distal edge of the distal end 806. The distal end 806 also preferably has an axial rotation prevention 10 feature, e.g., two (at least one) key slots 814a,814b extending proximally from the distal end 806. Each slot 814a,814b is shaped to accommodate the key flanges 708a,708b at the connection of the base 702 to the stem 706 when the distal end 806 is engaged with the stem 706. The material from which the insertion 15 handle 800 is formed (preferably, e.g., Ultem~~®~~), and also the presence of the key slots 814a,814b, permits the diameter of the hollow distal end 806 to expand as needed to engage the tapered stem 706 of the insertion plate 700. More particularly, the resting diameter (prior to any expansion) of the hollow distal 20 end 806 of the insertion handle 800 is incrementally larger than the initial diameter of the tapered proximal portion 710 of the stem 706 of the insertion plate 700, and incrementally smaller than the final diameter of the tapered proximal portion 710 of the stem 706 of the insertion plate 700. Accordingly, 25 longitudinally aligning the insertion handle shaft 802 with the stem 706, and thereafter pushing the hollow distal end 806 of the insertion handle shaft 802 toward the insertion plate 700, causes the hollow distal end 806 to initially readily encompass the tapered proximal portion 710 of the stem 706 (because the initial 30 diameter of the tapered proximal portion 710 is smaller than the resting diameter of the hollow tapered distal end 806). With continued movement of the insertion handle shaft 802 toward the insertion plate base 702, the hollow distal end 806 is confronted by the increasing diameter of the tapered proximal portion 710. 35 Accordingly, the diameter of the hollow distal end 806 expands (by permission of the shaft 802 body material and the key slots 814a,814b as the slots narrow) under the confrontation to accept

the increasing diameter. Eventually, with continued movement under force, the inner surface of the hollow distal end 806 is friction-locked to the outer surface of the tapered proximal portion 710. Each of the key slots 814a,814b straddles a
5 respective one of the key flanges 708a,708b at the connection of the base 702 to the stem 706. This enhances the ability of the insertion handle 800 to prevent rotation of the insertion handle shaft 802 relative to the insertion plate 700 (about the longitudinal axis of the insertion handle shaft 802). It should
10 be understood that other methods or mechanisms of establishing engagement of the stem 706 by the insertion handle 800 can be used without departing from the scope of the invention.

Once the insertion handle 800 is engaged with the insertion plate 700, manipulation of the insertion handle shaft 802 effects
15 manipulation of the cervical disc replacement device 400 and insertion plate 700 construct. The surgeon can therefore remove the construct from the implant tray, and insert the construct into the treatment area. More particularly, according to the implantation procedure of the invention, after the surgeon
20 properly prepares the intervertebral space (removes the damaged natural disc, modifies the bone surfaces that define the intervertebral space, and distracts the intervertebral space to the appropriate height), the surgeon inserts the cervical disc replacement device 400 into the intervertebral space from an
25 anterior approach, such that the upper and lower elements 500,600 are inserted between the adjacent vertebral bones with the element footprints fitting within the perimeter of the intervertebral space and with the teeth of the elements' vertebral body contact surfaces 502,602 engaging the vertebral
30 endplates, and with the flanges 506,606 of the upper and lower elements 500,600 flush against the anterior faces of the upper and lower vertebral bones, respectively. (As discussed above, the flanges 506,606 preferably have a lateral curvature that approximates the lateral curvature of the anterior faces of the
35 vertebral bones.)

Referring now to Figs. 7a-e, an insertion pusher 900 of the insertion instrumentation of the present invention is shown in

top (Fig. 7a), lateral (Fig. 7b), and anterior (Fig. 7c) views. Fig. 7d shows an antero-lateral perspective view of the insertion pusher 900 inserted into the insertion handle 800. Fig. 7e shows a magnified view of the proximal end of Fig. 7d.

5 Once the construct is properly positioned in the treatment area, the surgeon uses the insertion pusher 900 to disengage the insertion handle shaft 802 from the stem 706 of the insertion plate 700. More particularly, the insertion pusher 900 has a longitudinal shaft 902 having a preferably blunt distal end 904 and a proximal end 906 preferably having a flange 908. The shaft
10 902 of the insertion pusher 900 has a diameter smaller than the inner diameter of the insertion handle shaft 802, such that the shaft 902 of the insertion pusher 900 can be inserted into and translated within the longitudinal bore 804 of the insertion
15 handle shaft 802. (The longitudinal bore 804 preferably, for the purpose of accommodating the insertion pusher 900 and other purposes, extends the length of the insertion handle shaft 802.)

 The shaft 902 of the insertion pusher 900 is preferably as long as (or, e.g., at least as long as) the longitudinal bore 804. Accordingly, to remove the insertion handle shaft 802 from the
20 insertion plate 700, the shaft 902 of the insertion pusher 900 is inserted into the longitudinal bore 804 of the insertion handle shaft 802 and translated therein until the blunt distal end 904 of the pusher shaft 802 is against the proximal end of the
25 tapered stem 706 of the insertion plate 700. Because the shaft 902 of the insertion pusher 900 is as long as the longitudinal bore 804 of the insertion handle shaft 802, the flange 810 of the insertion handle 800 and the flange 908 of the insertion pusher
30 900 are separated by a distance (see Figs. 7d and 7e) that is equivalent to the length of that portion of the stem 706 that is locked in the distal end 806 of the insertion handle shaft 802. Accordingly, a bringing together of the flanges 810, 908 (e.g., by the surgeon squeezing the flanges 810, 908 toward one another) will overcome the friction lock between the distal end 806 of the
35 insertion handle shaft 802 and the stem 706 of the insertion plate 700, disengaging the insertion handle shaft 802 from the insertion plate 700 without disturbing the disposition of the

cervical disc replacement device 400 and insertion plate 700 construct in the treatment area.

Referring now to Figs. 8a-e, a drill guide 1000 of the insertion instrumentation of the present invention is shown in top (Fig. 8a), lateral (Fig. 8b), and anterior (Fig. 8c) views. Fig. 8d shows an antero-lateral perspective view of the drill guide 1000 inserted onto the stem 706 of the insertion plate 700.

Fig. 8e shows a magnified view of the distal end of Fig. 8d.

Once the insertion handle 800 has been removed, the surgeon uses the drill guide 1000 to guide the surgeon's drilling of the bone screws (described below) through the bone screw holes 508a,508b and 608a,608b of the upper 500 and lower 600 elements' flanges 506,606 and into the vertebral bones. More particularly, the drill guide 1000 has a longitudinal shaft 1002 having a configured distal end 1004 and a proximal end 1006 with a manipulation feature (e.g., lateral extensions 1008a,1008b). The lateral extensions 1008a,1008b are useful for manipulating the shaft 1002. The distal end 1004 is configured to have a shaft guiding feature (e.g., a central bore 1010) suitable for guiding the shaft 1002 in relation to the stem 706 of the insertion plate 700 therethrough. For example, the central bore 1010 accommodates the stem 706 so that the drill guide 1000 can be placed on and aligned with the stem 706. The longitudinal axis of the bore 1010 is preferably offset from the longitudinal axis of the drill guide shaft 1002. The distal end 1004 is further configured to have two guide bores 1012a,1012b that have respective longitudinal axes at preferred bone screw drilling paths relative to one another. More particularly, the central bore 1010, drill guide shaft 1002, and guide bores 1012a,1012b, are configured on the distal end 1004 of the drill guide 1000 such that when the central bore 1010 is disposed on the stem 706 of the insertion plate 700 (see Figs. 8d and 8e), the drill guide shaft 1002 can be rotated on the stem 706 into either of two preferred positions in which the guide bores 1012a,1012b are aligned with the bone screw holes 508a,508b or 608a,608b on either of the flanges 506 or 606. Stated alternatively, in a first preferred position (see Figs. 8d and 8e), the drill guide

1000 can be used to guide bone screws through the bone screw holes 508a,508b in the flange 506 of the upper element 500, and in a second preferred position (in which the drill guide is rotated 180 degrees, about the longitudinal axis of the stem 706, from the first preferred position), the same drill guide 1000 can be used to guide bone screws through the bone screw holes 608a,608b in the flange 606 of the lower element 600. When the drill guide 1000 is disposed in either of the preferred positions, the longitudinal axes of the guide bores 1012a,1012b are aligned with the bone screw holes 508a,508b or 608a,608b on the flanges 506 or 606, and are directed along preferred bone screw drilling paths through the bone screw holes.

Accordingly, to secure the upper element flange 506 to the upper vertebral body, the surgeon places the drill guide shaft 1002 onto the stem 706 of the insertion plate 700, and rotates the drill guide 1000 into the first preferred position. Preferably, the surgeon then applies an upward pressure to the drill guide 1000, urging the upper element 500 tightly against the endplate of the upper vertebral body. Using a suitable bone drill and cooperating drill bit, the surgeon drills upper tap holes for the upper bone screws. Once the upper tap holes are drilled, the surgeon rotates the drill guide shaft 1002 on the stem 706 of the insertion plate 700 until the guide bores 1012a,1012b no longer cover the upper bone screw holes 508a,508b. The surgeon can then screw the upper bone screws into the upper tap holes using a suitable surgical bone screw driver.

Additionally, to secure the lower element flange 606 to the lower vertebral body, the surgeon further rotates the drill guide shaft 1002 on the stem 706 of the insertion plate 700 until the drill guide 1000 is in the second preferred position. Preferably, the surgeon then applies a downward pressure to the drill guide 1000, urging the lower element 600 tightly against the endplate of the lower vertebral body. Using the suitable bone drill and cooperating drill bit, the surgeon drills lower tap holes for the lower bone screws. Once the lower tap holes are drilled, the surgeon rotates the drill guide shaft 1002 on the stem 706 of the insertion plate 700 until the guide bores 1012a,1012b no longer

cover the lower bone screw holes 608a,608b. The surgeon can then screw the lower bone screws into the lower tap holes using the suitable surgical bone screw driver.

It should be noted that the bone screws (or other elements of the invention) may include features or mechanisms that assist in prevent screw backup. Such features may include, but not be limited to, one or more of the following: titanium plasma spray coating, bead blasted coating, hydroxylapatite coating, and grooves on the threads.

Once the elements 500,600 are secured to the adjacent vertebral bones, the surgeon removes the drill guide 1000 from the stem 706 of the insertion plate 700 and from the treatment area (see Fig. 9a). Using a suitable surgical screw driver, the surgeon then removes the mounting screws 714a,714b that hold the insertion plate 700 against the elements' flanges 506,606, and removes the insertion plate 700 and the mounting screws 714a,714b from the treatment area (see Fig. 9b).

Referring now to Figs. 10a-f, a retaining clip 1150a of the present invention is shown in top (Fig. 10a), lateral (Fig. 10b), posterior (Fig. 10c), anterior (Fig. 10d), postero-lateral perspective (Fig. 10e), and antero-lateral perspective (Fig. 10f) views. (The features of retaining clip 1150a are exemplary of the features of the like-numbered features of retaining clip 1150b, which are referenced by b's rather than a's.) Referring now to Figs. 11a-e, a clip applicator 1100 of the insertion instrumentation of the present invention is shown in top (Fig. 11a), lateral (Fig. 11b), and anterior (Fig. 11c) views. Fig. 11d shows a postero-lateral perspective view of the clip applicator 1100 holding two retaining clips 1150a,1150b of the present invention. Fig. 11e shows an antero-lateral perspective view of Fig. 11d. Referring now to Figs. 12a-h, the clip applicator 1100 is shown applying the retaining clips 1150a,1150b to the cervical disc replacement device 400. Figs. 12b-h show anterior (Fig. 12b), posterior (Fig. 12c), top (Fig. 12d), bottom (Fig. 12e), lateral (Fig. 12f), antero-lateral perspective (Fig. 12g), and postero-lateral perspective (Fig. 12h) views of the cervical disc replacement device 400 after the retaining clips

1150a,1150b have been applied.

Once the mounting screws 714a,714b and the insertion plate 700 are removed, the surgeon uses the clip applicator 1100 to mount the retaining clips 1150a,1150b on the flanges 506,606 to assist in retaining the bone screws. As shown in Figs. 10a-f, each of the clips 1150a,1150b preferably has an applicator attachment feature (e.g., a central attachment bore 1152a,1152b) and, extending therefrom, a pair of bone screw retaining features (e.g., oppositely directed laterally extending flanges 1156a,1156b and 1158a,1158b) and a flange attachment feature (e.g., an upwardly (or downwardly) extending hooked flange 1160a,1160b). The extent of the hook flange 1160a,1160b is preferably formed to bend in toward the base of the hook flange 1160a,1160b, such that the enclosure width of the formation is wider than the mouth width of the formation, and such that the extent is spring biased by its material composition toward the base. The enclosure width of the formation accommodates the width of the body of a flange 506,606 of the cervical disc replacement device 400, but the mouth width of the formation is smaller than the width of the flange 506,606. Accordingly, and referring now to Figs. 12b-h, each clip 1150a,1150b can be applied to an element flange 506,606 such that the hook flange 1160a,1160b grips the element flange 506,606, by pressing the hook's mouth against the edge of the element flange 506,606 with enough force to overcome the bias of the hook flange's extent toward the base, until the flange 506,606 is seated in the hook's enclosure. The attachment bore 1152a,1152b of the clip 1150a,1150b is positioned on the clip 1150a,1150b such that when the clip 1150a,1150b is properly applied to the flange 506,606, the attachment bore 1152a,1152b is aligned with the mounting screw hole 509,609 on the flange 506,606 (see Figs. 12b-h). Further, the posterior opening of the attachment bore 1152a,1152b is preferably surrounded by a clip retaining features (e.g., a raised wall 1162a,1162b), the outer diameter of which is dimensioned such that the raised wall 1162a,1162b fits into the mounting screw hole 509,609 on the element flange 506,606. Thus, when the clip 1150a,1150b is so applied to the element flange

506,606, the element flange 506,606 will be received into the hook's enclosure against the spring bias of the hook's extent, until the attachment bore 1152a,1152b is aligned with the mounting screw hole 509,609, at which time the raised wall 1162a,1162b will snap into the mounting screw hole 509,609 under the force of the hook's extent's spring bias. This fitting prevents the clip 1150a,1150b from slipping off the flange 506,606 under stresses in situ. Each of the laterally extending flanges 1156a,1156b and 1158a,1158b of the clip 1150a,1150b is sized to cover at least a portion of a respective one of the bone screw heads when the clip 1150a,1150b is attached in this manner to the flange 506,606 (see Figs. 12b-h), so that, e.g., the clips 1150a,1150b help prevent the bone screws from backing out.

Referring again to Figs. 11a-e, the clip applicator 1100 has a pair of tongs 1102a,1102b hinged at a proximal end 1104 of the clip applicator 1100. Each tong 1102a,1102b has an attachment feature (e.g., a nub 1108a,1108b) at a distal end 1106a,1106b. Each nub 1108a,1108b is dimensioned such that it can be manually friction locked into either of the attachment bores 1152a,1152b of the retaining clips 1150a,1150b. Thus, both clips 1150a,1150b can be attached to the clip applicator 1100, one to each tong 1102a,1102b (see Figs. 11d and 11e). Preferably, as shown in Figs. 11d and 11e, the clips 1150a,1150b are attached so that their hook flanges 1154a,1154b are directed toward one another, so that they are optimally situated for attachment to the element flanges 506,606 of the cervical disc replacement device 400 (see Fig. 12a).

Preferably, the clips 1150a,1150b are attached to the clip applicator 1100 as described above prior to delivery to the surgeon. The assembly is preferably provided sterile to the surgeon in a blister pack. Accordingly, when the surgeon is ready to mount the clips 1150a,1150b to the element flanges 506,606 of the cervical disc replacement device 400, the surgeon opens the blister pack and inserts the tongs 1102a,1102b of the clip applicator 1100 (with the clips 1150a,1150b attached) into the treatment area.

Accordingly, and referring again to Figs. 12a-h, the clips

1150a,1150b can be simultaneously clipped to the upper 500 and lower 600 elements' flanges 506,606 (one to each flange 506,606) using the clip applicator 1100. More particularly, the mouths of the clips 1150a,1150b can be brought to bear each on a respective one of the flanges 506,606 by manually squeezing the tongs 1102a,1102b (having the clips 1150a,1150b attached each to a set of the distal ends of the tongs 1102a,1102b) toward one another when the mouths of the clips 1150a,1150b are suitably aligned with the flanges 506,606 (see Fig. 12a). Once the clips 1150a,1150b have been attached to the flanges 506,660 with the raised walls 1162a,1162b fitting into the mounting screw holes 509,609 of the flanges 506,606, the clip applicator 1100 can be removed from the clips 1150a,1150b by manually pulling the nubs 1108a,1108b out of the attachment bores 1152a,1152b, and the clip applicator 1100 can be removed from the treatment area.

Turning to Figs. 19a and b, an alternate retaining device to retaining clips 1150a and b, is shown. The surgeon can secure the bone screws through use of retaining devices 1900a,1900b comprising threaded members 1910a,1910b and head flanges 1920a,1920b extending therefrom. As is seen in the figures, mounting screw holes 509,609 are threaded for use with mounting screws 714a,714b. This same threaded configuration is useable with threaded members 1910a,1910b. In particular, once the mounting screws 714a,714b and the insertion plate 700 are removed, the surgeon applies retaining devices 1900a,1900b by inserting and rotating threaded members 1910a,1910b into mounting screw holes 509,609. Upon tightening of retaining devices 1900a,1900b in this manner, rim portions 1930a,1930b thereof cover at least a portion of a respective one of the bone screw heads so that the bone screws are prevented from backing out of bone screw holes 508a,508b,608a,608b. Preferably, each of the head flanges 1920a,1920b has a thickness dimension 1940a,1940b and/or a configuration of stress relief areas 1960a, 1960b (or other suitable feature), such as in a convex construction 1950a,1950b as viewed from the perspective of the threaded member 1910a, 1910b, that allows it to flex toward a flatter state (stated alternatively, bending backward) as the threaded member

1910a,1910b is advanced into the mounting screw hole 509,609 under force, and this flexing stresses the threaded member 1910a,1910b to expand or exert pressure upon its threaded connection within the associated mounting screw hole 509,609, thus preventing backout of the threaded member 1910a,1910b from the mounting screw hole 509,609. In this manner, the retaining devices 1900a,1900b not only prevent backout of the bones screws from the bone screw holes 508a,508b,608a,608b, but also prevent backout of the threaded member 1910a,1910b from the mounting screw holes 509,609.

After implanting the cervical disc replacement device 400 as described, the surgeon follows accepted procedure for closing the treatment area.

Referring now to Figs. 14a-e, an alternate dual cervical disc replacement device configuration and alternate insertion plates for use therewith, suitable, for example, for implantation in two adjacent cervical intervertebral spaces, are illustrated in exploded perspective (Fig. 14a), anterior (Fig. 14b), posterior (Fig. 14c), lateral (Fig. 14d), and collapsed perspective (Fig. 14e) views. Referring now also to Figs. 15a-c, an alternate upper element of the configuration is shown in posterior (Fig. 15a), anterior (Fig. 15b), and antero-lateral (Fig. 15c) views. Referring now also to Figs. 16a-c, an alternate lower element of the configuration is shown in posterior (Fig. 16a), anterior (Fig. 16b), and antero-lateral (Fig. 16c) views. Referring now also to Figs. 17a-c, an alternate, upper, insertion plate of the configuration is shown in anterior (Fig. 17a), posterior (Fig. 17b), and antero-lateral (Fig. 17c) views. Referring now also to Figs. 18a-c, an alternate, lower, insertion plate of the configuration is shown in anterior (Fig. 18a), posterior (Fig. 18b), and antero-lateral (Fig. 18c) views.

More particularly, the alternate dual cervical disc replacement device configuration 1350 is suitable, for example, for implantation into two adjacent cervical intervertebral spaces. The configuration preferably, as shown, includes an alternate, upper, cervical disc replacement device 1400

(including an upper element 1500 and an alternate, lower, element 1600), for implantation into an upper cervical intervertebral space, and further includes an alternate, lower, cervical disc replacement device 2400 (including an alternate, upper, element 5 2500 and a lower element 2600), for implantation into an adjacent, lower, cervical intervertebral space. The illustrated alternate, upper, embodiment of the cervical disc replacement device is identical in structure to the cervical disc replacement device 400 described above (and thus like components are like 10 numbered, but in the 1400s rather than the 400s, in the 1500s rather than the 500s, and in the 1600s rather than the 600s), with the exception that the flange 1606 of the lower element 1600 is configured differently and without bone screw holes. The illustrated alternate, lower, embodiment of the cervical disc 15 replacement device is identical in structure to the cervical disc replacement device 400 described above (and thus like components are like numbered, but in the 2400s rather than the 400s, in the 2500s rather than the 500s, and in the 2600s rather than the 600s), with the exception that the flange 2506 of the upper 20 element 2500 is configured differently and without bone screw holes.

More particularly, in the alternate, upper, cervical disc replacement device 1400 of this alternate configuration, the flange 1606 of the lower element 1600 does not have bone screw 25 holes, but has at least one mounting feature (e.g., a mounting screw hole) 1609 for attaching the lower element 1600 to the alternate, upper, insertion plate 1700 (described below). Similarly, and more particularly, in the alternate, lower, cervical disc replacement device 2400 of this alternate 30 configuration, the flange 2506 of the upper element 2500 does not have bone screw holes, but has at least one mounting feature (e.g., a mounting screw hole) 2509 for attaching the upper element 2500 to the alternate, lower, insertion plate 2700 (described below). As can be seen particularly in Figs. 14a-c, 35 15b, 16b, 17a, and 18a, the extent of the flange 1606 is laterally offset to the right (in an anterior view) from the midline (and preferably limited to support only the mounting

screw hole 1609), and the extent of the flange 2506 is laterally offset to the left (in an anterior view) from the midline (and preferably limited to support only the mounting screw hole 2509), so that the flanges 1606,2506 avoid one another when the alternate lower element 1600 of the alternate, upper, cervical disc replacement device 1400, and the alternate upper element 2500 of the alternate, lower, cervical disc replacement device 2400, are implanted in this alternate configuration (Figs. 14a-e).

10 It should be noted that the alternate, upper, cervical disc replacement device 1400 does not require both elements 1500,1600 to be secured to a vertebral body. Only one need be secured to a vertebral body, because due to natural compression in the spine pressing the elements' bearing surfaces together, and the
15 curvatures of the saddle-shaped bearing surfaces preventing lateral, anterior, or posterior movement relative to one another when they are compressed against one another, if one element (e.g., the upper element 1500) is secured to a vertebral body (e.g., to the upper vertebral body by bone screws through the
20 bone screw holes 1508a,1508b of the element flange 1506), the other element (e.g., the alternate, lower, element 1600) cannot slip out of the intervertebral space, even if that other element is not secured to a vertebral body (e.g., to the middle vertebral body). Similarly, the alternate, lower, cervical disc
25 replacement device 2400 does not require both elements 2500,2600 to be secured to a vertebral body. Only one need be secured to a vertebral body, because due to natural compression in the spine pressing the elements' bearing surfaces together, and the
30 curvatures of the saddle-shaped bearing surfaces preventing lateral, anterior, or posterior movement relative to one another when they are compressed against one another, if one element (e.g., the lower element 2600) is secured to a vertebral body (e.g., to the lower vertebral body by bone screws through the
35 bone screw holes 2608a,2608b of the element flange 2606), the other element (e.g., the alternate, upper, element 2500) cannot slip out of the intervertebral space, even if that other element is not secured to a vertebral body (e.g., to the middle vertebral

body).

Accordingly, the alternate, upper, insertion plate 1700 is provided to facilitate a preferred simultaneous implantation of the upper and lower elements 1500,1600 of the alternate, upper, cervical disc replacement device 1400 into the upper intervertebral space. Similarly, the alternate, lower, insertion plate 2700 is provided to facilitate a preferred simultaneous implantation of the upper and lower elements 2500,2600 of the alternate, lower, cervical disc replacement device 2400 into the lower intervertebral space. The upper and lower elements 1500,1600 are held by the insertion plate 1700 (preferably using mounting screws 1714a,1714b) in a preferred relationship to one another that is suitable for implantation, identical to the preferred relationship in which the upper and lower elements 500,600 are held by the insertion plate 700 as described above. Similarly, the upper and lower elements 2500,2600 are held by the insertion plate 2700 (preferably using mounting screws 2714a,2714b) in a preferred relationship to one another that is suitable for implantation, identical to the preferred relationship in which the upper and lower elements 500,600 are held by the insertion plate 700 as described above.

The illustrated alternate, upper, insertion plate 1700 is identical in structure to the insertion plate 700 described above (and thus like components are like numbered, but in the 1700s rather than the 700s), with the exception that the lower flange 1704b is offset from the midline (to the right in an anterior view) to align its mounting screw hole 1712b with the offset mounting screw hole 1609 of the alternate lower element 1600 of the alternate, upper, cervical disc replacement device 1400. Similarly, the illustrated alternate, lower, insertion plate 2700 is identical in structure to the insertion plate 700 described above (and thus like components are like numbered, but in the 2700s rather than the 700s), with the exception that the upper flange 2704a is offset from the midline (to the left in an anterior view) to align its mounting screw hole 2712a with the offset mounting screw hole 2509 of the alternate upper element 2500 of the alternate, lower, cervical disc replacement device

2400.

Accordingly, the upper and lower elements 1500,1600, being held by the insertion plate 1700, as well as the upper and lower elements 2500,2600, being held by the insertion plate 2700, can be implanted using the insertion handle 800, insertion pusher 900, drill guide 1000, clips 1150a,1150b (one on the upper element flange 1506, and one on the lower element flange 2606, because only the upper element 1500 and the lower element 2600 are secured by bone screws), and clip applicator 1100, in the manner described above with respect to the implantation of the cervical disc replacement device 400.

It should be noted that the described alternate configuration (that includes two cervical disc replacement devices) presents the cervical disc replacement devices to the surgeon in a familiar manner. That is, by way of explanation, current cervical fusion surgery involves placing a fusion device (e.g., bone or a porous cage) in between the upper and middle cervical intervertebral bones, and in between the middle and lower vertebral bones, and attaching an elongated two-level cervical fusion plate to the anterior aspects of the bones. Widely used two-level cervical fusion devices (an example two level fusion plate 1350 is shown in anterior view in Fig. 13c and in lateral view in Fig. 13d) are configured with a pair of laterally spaced bone screw holes 1352a,1352b on an upper end 1354 of the plate 1350, a pair of laterally spaced bone screw holes 1356a,1356b on a lower end 1358 of the plate 1350, and a pair of laterally spaced bone screw holes 1360a,1360b midway between the upper and lower ends 1354,1358. To attach the plate 1350 to the bones, bone screws are disposed through the bone screw holes and into the corresponding bones. This prevents the bones from moving relative to one another, and allows the bones to fuse to one another with the aid of the fusion device.

Accordingly, as can be seen in Fig. 14b, when the upper and lower elements 1500,1600 of the cervical disc replacement device 1400, and the upper and lower elements 2500,2600 of the cervical disc replacement device 2400, are held in the preferred spatial relationship and aligned for implantation, the upper element

flange 1506 and lower element flange 2606, and their bone screw holes 1508a,1508b and 2608a,2608b, present to the surgeon a cervical hardware and bone screw hole configuration similar to a familiar two level cervical fusion plate configuration (as described above, a middle pair of bone screws holes is not needed; however, middle bone screw holes are contemplated by the present invention for some embodiments, if necessary or desirable). The mounting of the elements 1500,1600 to the insertion plate 1700 allows the elements 1500,1600 to be manipulated as a single unit for implantation (by manipulating the insertion plate 1700), similar to the way a cervical fusion plate is manipulatable as a single unit for attachment to the bones. Similarly, the mounting of the elements 2500,2600 to the insertion plate 2700 allows the elements 2500,2600 to be manipulated as a single unit for implantation (by manipulating the insertion plate 2700), similar to the way a cervical fusion plate is manipulatable as a single unit for attachment to the bones. This aspect of the present invention simplifies and streamlines the cervical disc replacement device implantation procedure.

While there has been described and illustrated specific embodiments of cervical disc replacement devices and insertion instrumentation, it will be apparent to those skilled in the art that variations and modifications are possible without deviating from the broad spirit and principle of the invention. The invention, therefore, shall not be limited to the specific embodiments discussed herein.

Industrial Applicability

The present invention has applicability in the field of manufacturing instruments for inserting and removing cervical disc replacement trials, and inserting and securing cervical disc replacement devices, and methods of use thereof.

CLAIMS

What is claimed is:

5 1. An intervertebral disc replacement trial, comprising:
a shaft having a handle at a proximal end; and
a head disposed at a distal end of the shaft, the head
including first and second surfaces that are spaced apart and
sized for insertion into at least one intervertebral disc space
10 defined by respective endplates of an adjacent pair of vertebral
bones of a spinal column, and for facilitating distraction of the
vertebral bones in a direction along a longitudinal axis of the
spinal column.

15 2. The trial of claim 1, wherein the first surface
includes a generally oval footprint area for operative engagement
with an endplate of a first one of the vertebral bones, and the
second surface includes an area for operative engagement with an
endplate of a second one of the vertebral bones.

20 3. The trial of claim 1, wherein at least one of:
the first surface includes a substantially convex area for
operative engagement with an endplate of a first one of the
vertebral bones;

25 the substantially convex area of the first surface is sized
and shaped to operatively engage the endplate of the first
vertebral bone, which is a lower endplate thereof having a
substantially concave character;

30 the second surface includes a substantially flat area for
operative engagement with an endplate of a second one of the
vertebral bones; and

35 the substantially flat area of the second surface is sized
and shaped to operatively engage the endplate of the second
vertebral bone, which is an upper endplate thereof having a
substantially flat character.

4. The trial of claim 1, wherein at least one of:

the first surface is tapered towards its distal end to facilitate insertion of the head into the at least one intervertebral disc space; and

the second surface is tapered towards its distal end to facilitate insertion of the head into the at least one intervertebral disc space.

5 5. The trial of claim 4, wherein the first surface is tapered at about five degrees, and the second surface is tapered at about four degrees.

6. The trial of claim 1, further comprising at least one rib extending transversely away from the shaft and longitudinally along the shaft substantially to the head to provide stiffening to the head and shaft such that the head may be used to urge the vertebral bones apart.

7. An intervertebral disc replacement trial, comprising:
a shaft having a handle at a proximal end;
20 a head disposed at a distal end of the shaft, the head including first and second spaced apart surfaces operative for insertion into at least one intervertebral disc space defined by respective endplates of an adjacent pair of vertebral bones of a spinal column; and
25 a stop member operable to prevent over-insertion of the head into the intervertebral disc space of the spinal column.

8. The trial of claim 7, wherein the stop member includes a stop element transversely extending from the head that is sized and positioned to engage at least one of the vertebral bones to prevent over-insertion of the head into the intervertebral disc space of the spinal column.

9. The trial of claim 8, wherein the stop element extends substantially perpendicularly from an anterior end of the head such that it engages an anterior surface of a lower one of the vertebral bones prevent over-insertion of the head into the

intervertebral disc space of the spinal column.

10. A set of intervertebral disc replacement trials, each trial comprising:

5 a shaft having a handle at a proximal end; and

a head disposed at a distal end of the shaft, the head including first and second surfaces that are spaced apart and sized for insertion into at least one intervertebral disc space defined by respective endplates of an adjacent pair of vertebral
10 bones of a spinal column,

wherein one or more of the trials have heads of differing size to facilitate at least one of: (i) determining an appropriate size of an intervertebral disc replacement device to dispose within the intervertebral disc space; and (ii)
15 distraction of the vertebral bones in a direction along a longitudinal axis of the spinal column.

11. The trial set of claim 10, wherein a head thickness, measured substantially from the first to the second surface, of
20 at least one of the trials differs from a head thickness of at least one other of the trials.

12. The trial set of claim 11, wherein the head thicknesses differ by about 1 mm.

25

13. The trial set of claim 10, wherein a head square area of at least one of the trials differs from a head square area of at least one other of the trials.

30

14. The trial set of claim 13, wherein at least one of: a head thickness, measured substantially from the first to the second surface, of at least one of the trials differs from a head thickness of at least one other of the trials; and

a least two heads of substantially the same head thickness
35 have differing respective head square areas.

15. The trial set of claim 13, further comprising one or

more intervertebral disc replacement devices.

16. A method of using a set of intervertebral disc replacement trials, each trial including a shaft having a handle
5 at a proximal end, and a head disposed at a distal end of the shaft, the head including first and second surfaces that are spaced apart and sized for insertion into at least one intervertebral disc space defined by respective endplates of an adjacent pair of vertebral bones of a spinal column, the method
10 comprising at least:

inserting a first of the trials into one of the intervertebral disc spaces to facilitate at least some distraction of the vertebral bones in a direction along a longitudinal axis of the spinal column; and

15 inserting a second of the trials into the intervertebral disc space to facilitate at least some further distraction of the vertebral bones along the longitudinal axis, where the second trial has a larger head thickness, measured substantially from the first to the second surface, than that of the first trial.

20

17. The method of claim 16, further comprising levering the handle of at least one of the first and second trials to facilitate the distraction of the vertebral bones.

25 18. The method of claim 16, further comprising repeating the insertion of further trials having larger and larger head thicknesses to facilitate the distraction of the vertebral bones to a target distance.

30 19. The method of claim 18, wherein the target distance is one that substantially maximizes the intervertebral space while substantially preserving an annulus and ligaments associated with the vertebral bones.

35 20. The method of claim 16, further comprising inserting an intervertebral disc replacement device into the intervertebral space after it has been distracted to the target distance.

21. A method of replacing at least a portion of an intervertebral disc of an intervertebral disc space of a spinal column, the intervertebral disc space defined at least by
5 respective endplates of first and second adjacent vertebral bones, the method comprising:

inserting at least one intervertebral disc replacement trial into the intervertebral disc space to distract same in a direction along a longitudinal axis of the spinal column; and
10 simultaneously inserting first and second members of an intervertebral disc replacement device into an intervertebral disc space of the spinal column.

22. The method of claim 21, wherein the step of inserting
15 at least one intervertebral disc replacement trial includes using a set of intervertebral disc replacement trials to displace the intervertebral disc space, at least two of the intervertebral disc replacement trials having differing head thicknesses to facilitate distraction of the vertebral bones along the
20 longitudinal axis.

23. The method of claim 22, further comprising:
inserting a first of the trials into the intervertebral disc space to facilitate at least some distraction of the first and
25 second vertebral bones; and
inserting a second of the trials into the intervertebral disc space to facilitate at least some further distraction of the first and second vertebral bones, where the second trial has a larger head thickness than that of the first trial.

30
24. The method of claim 23, further comprising repeating the insertion of further trials having larger and larger head thicknesses to facilitate the distraction of the vertebral bones to a target distance, wherein the target distance is one that
35 substantially maximizes the intervertebral space while substantially preserving an annulus and ligaments associated with the vertebral bones.

25. The method of claim 21, further comprising levering a handle of the at least one trial to facilitate the distraction of the first and second vertebral bones.

5

26. The method of claim 21, further comprising orienting and maintaining first and second articulation surfaces of the respective first and second members of the intervertebral disc replacement device in substantial registration with one another during their simultaneous insertion into the intervertebral disc space.

10

27. The method of claim 26, further comprising manipulating the first and second members as a single unit by way of an intervening insertion plate such that they may be at least one of inserted into and moved within the intervertebral disc space without substantially changing their orientation with respect to one another.

15

28. The method of claim 27, further comprising using an insertion handle that is adapted to detachably engage the insertion plate in order to manipulate the first and second members as a single unit.

20

29. The method of claim 28, wherein the insertion handle, insertion plate and the first and second members are provided in a sterile assembly in a package for access by a surgeon.

25

30

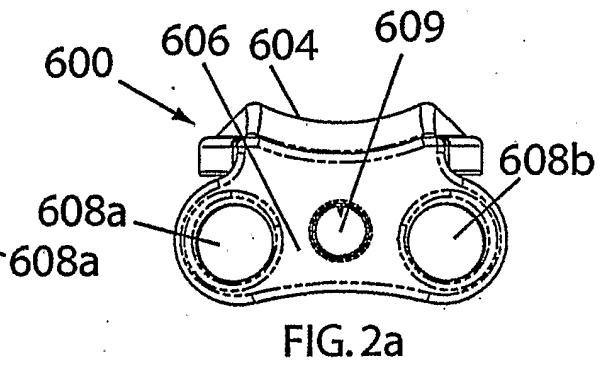
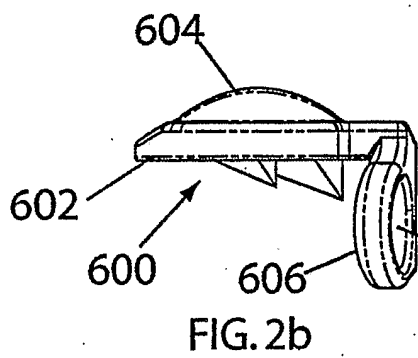
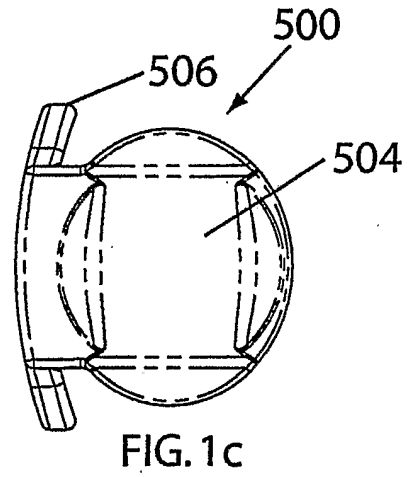
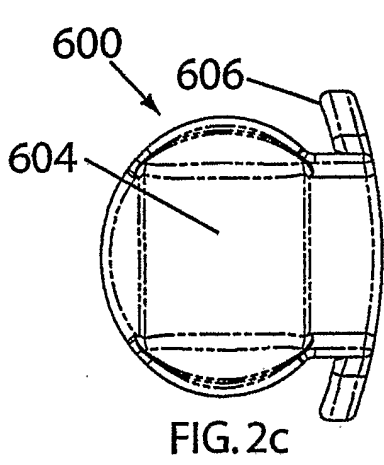
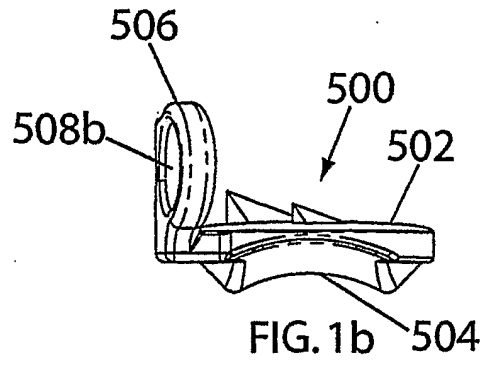
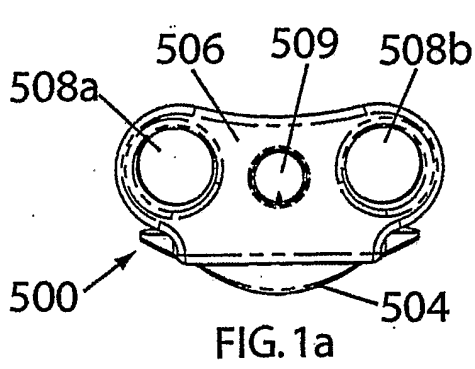

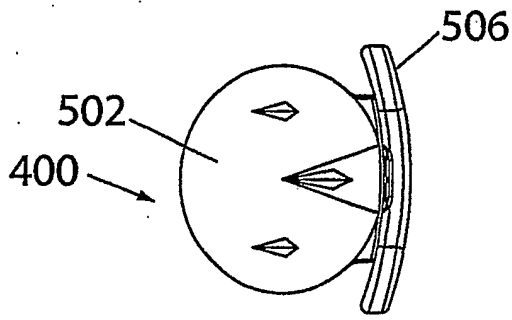

Fig. 3a

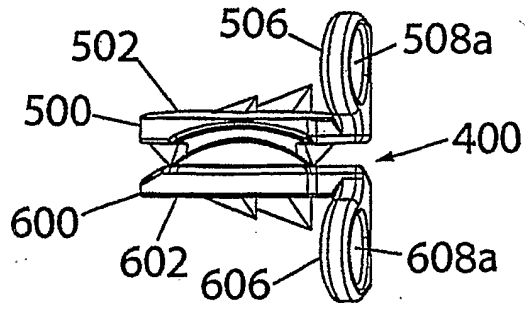

Fig. 3b

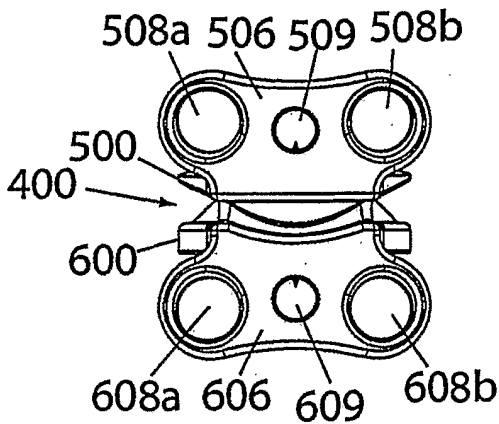

Fig. 3c

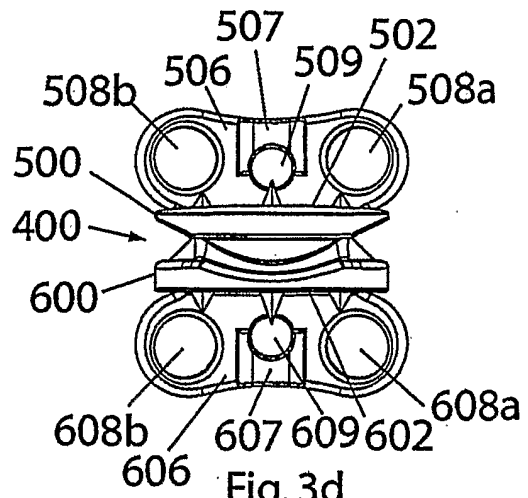

Fig. 3d

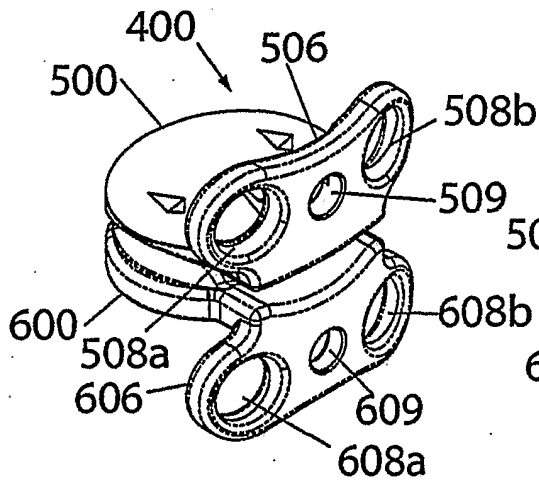

Fig. 3e

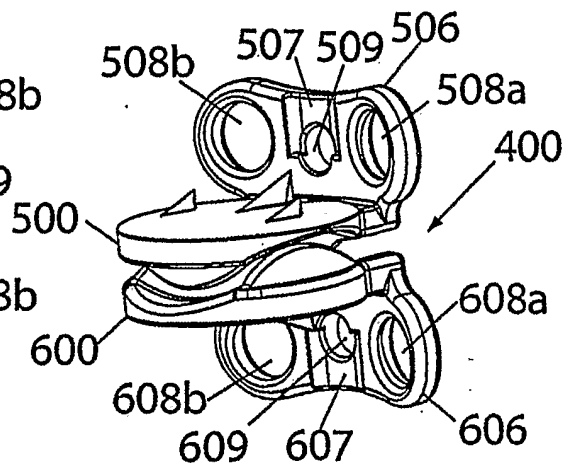
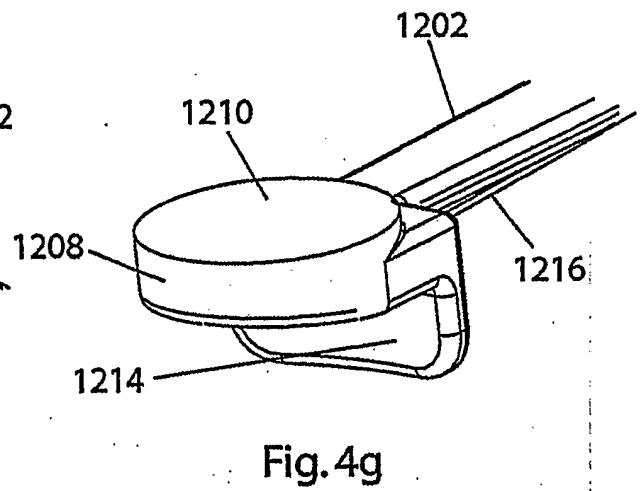
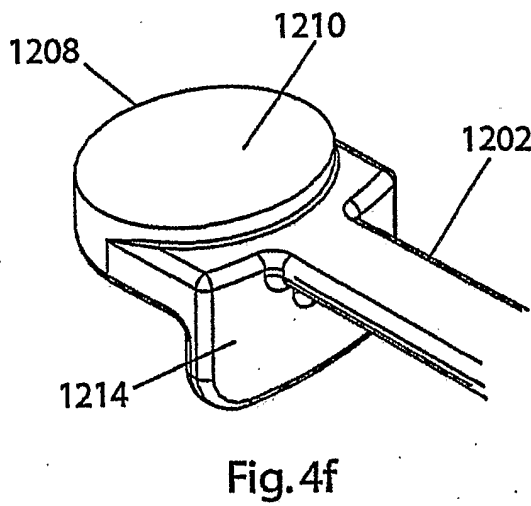
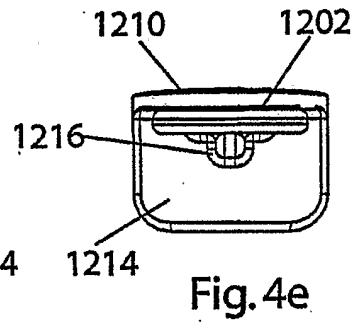
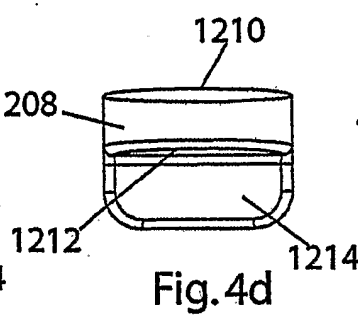
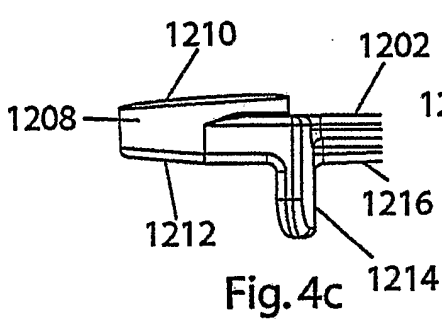
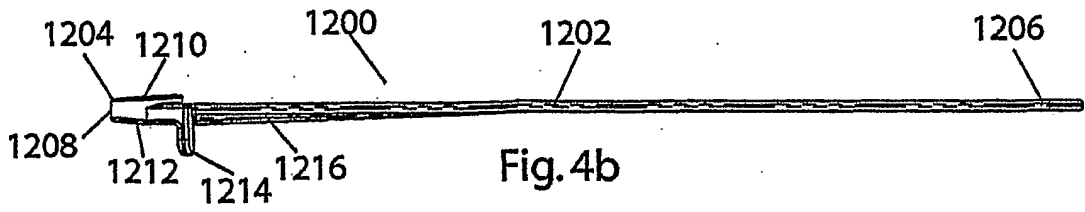
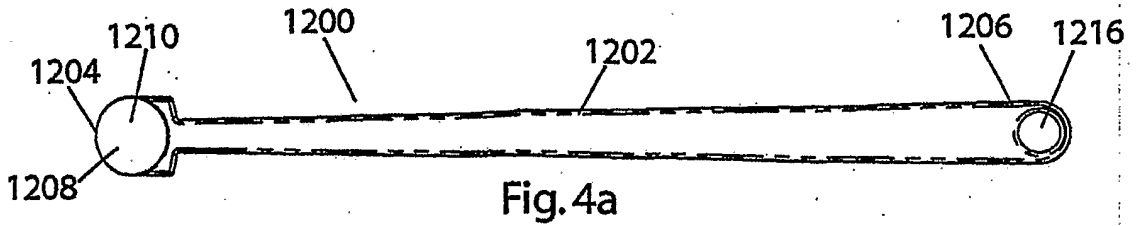

Fig. 3f



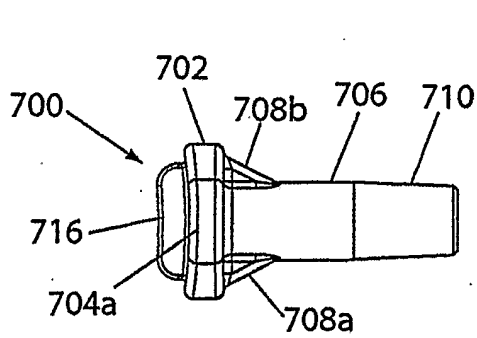

Fig. 5a

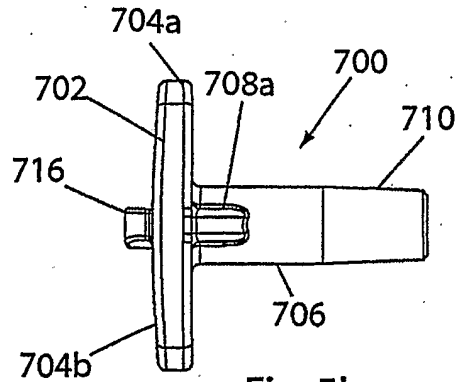

Fig. 5b

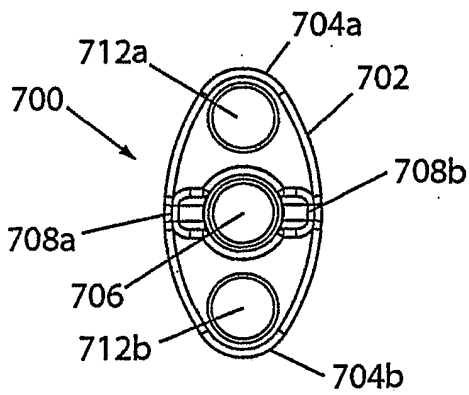

Fig. 5c

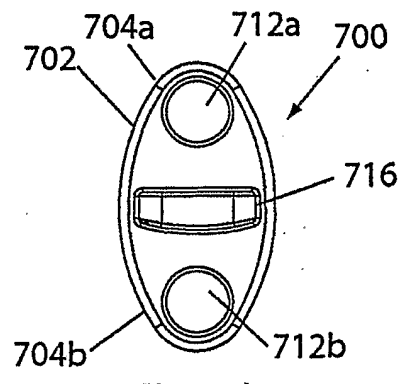

Fig. 5d

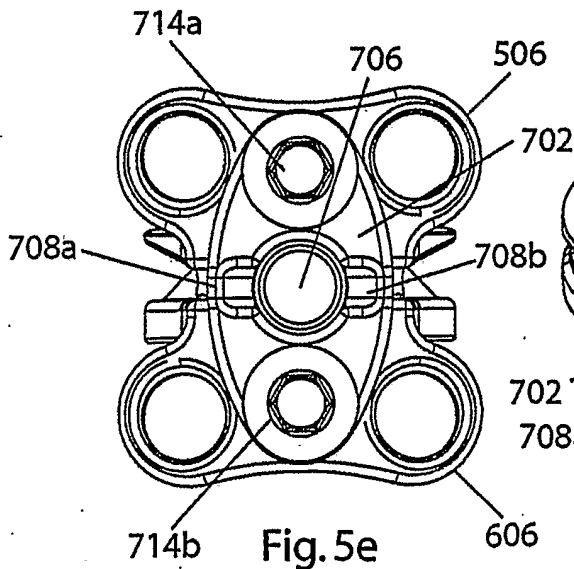

Fig. 5e

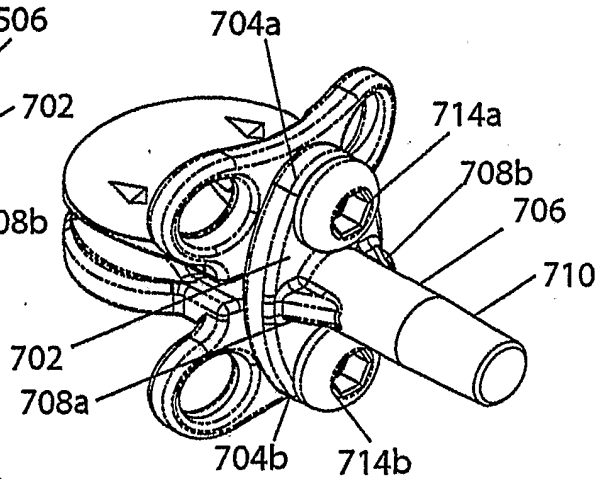
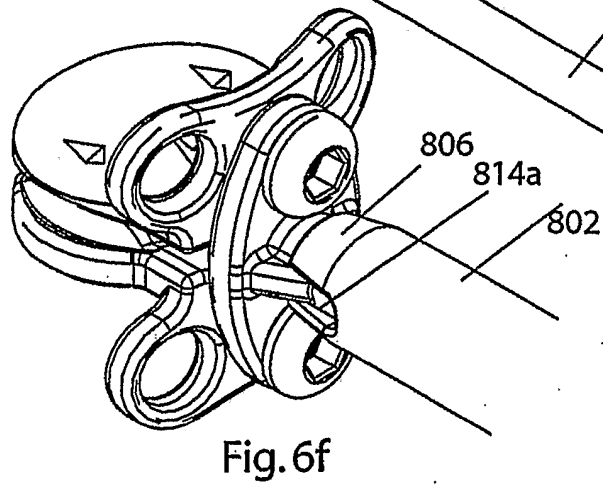
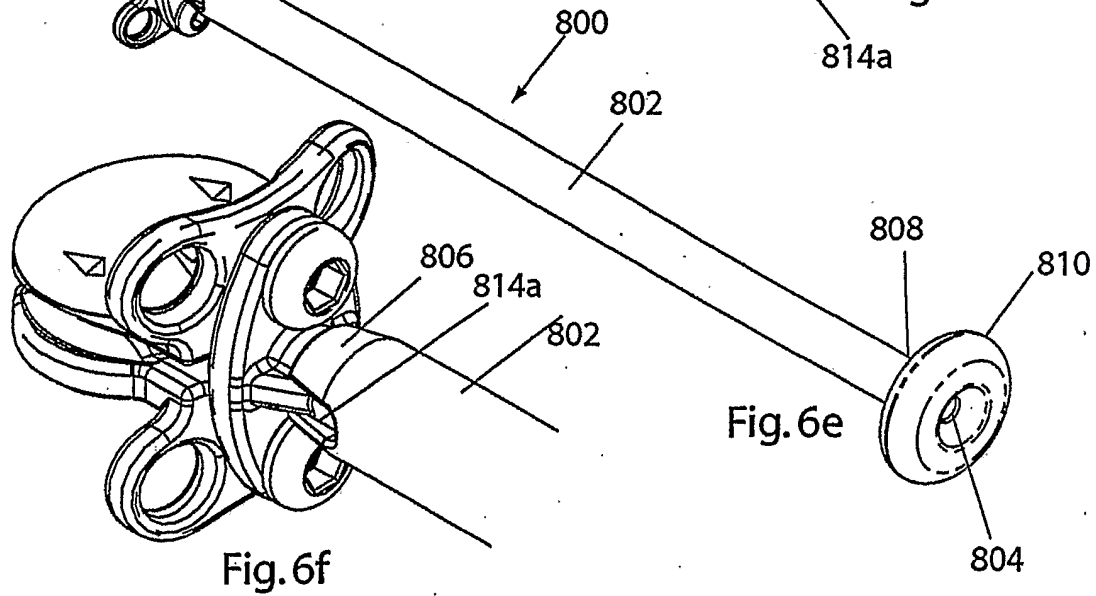
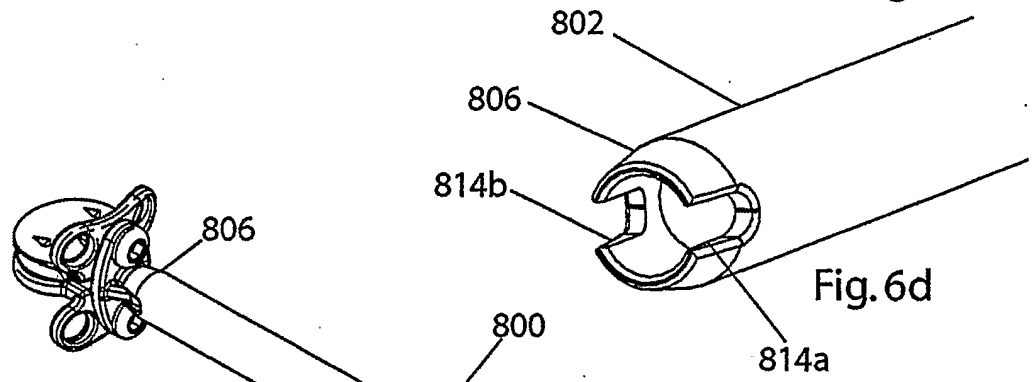
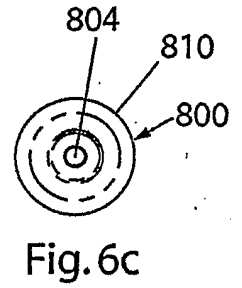
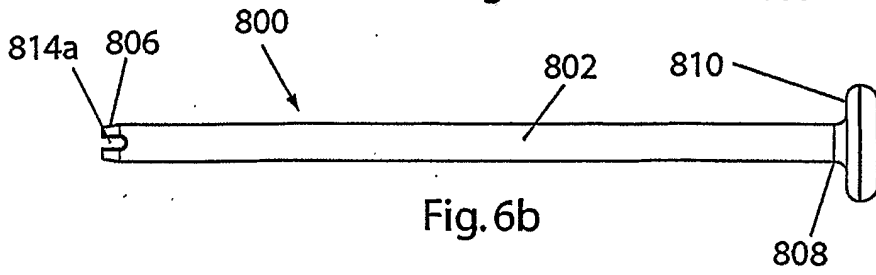
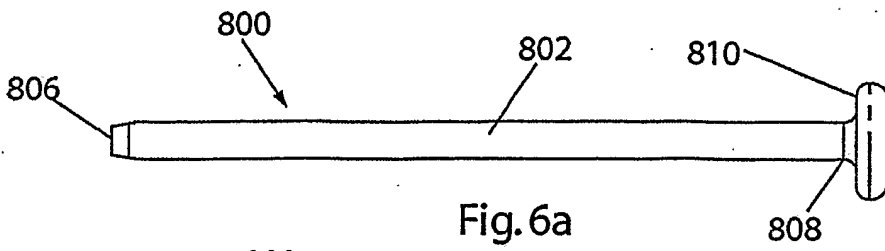
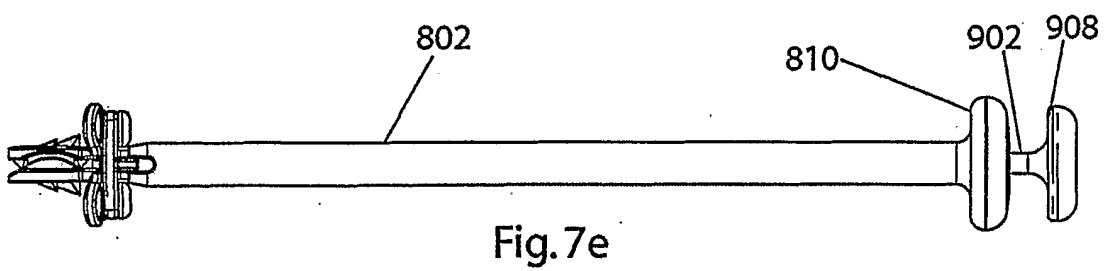
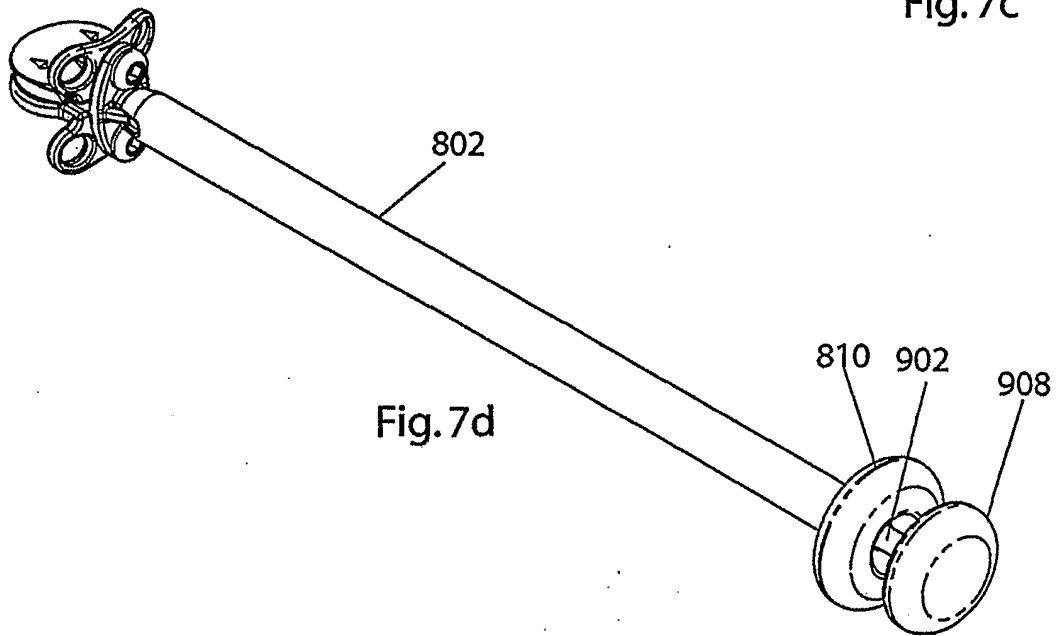
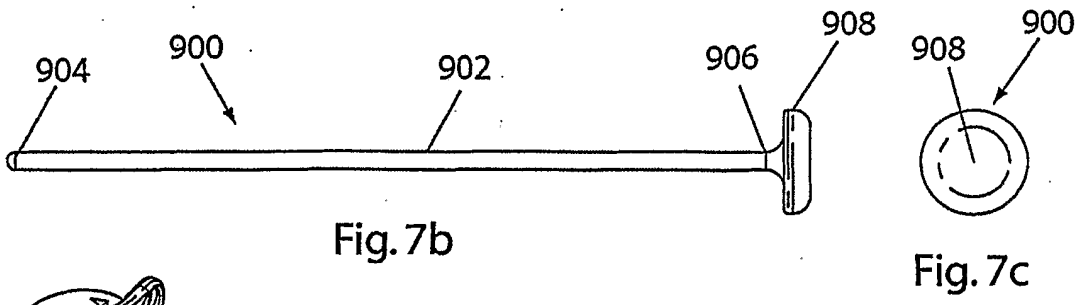
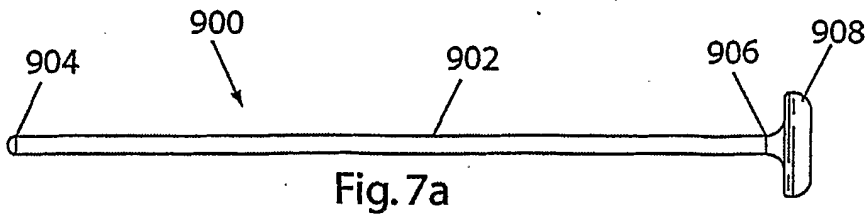

Fig. 5f





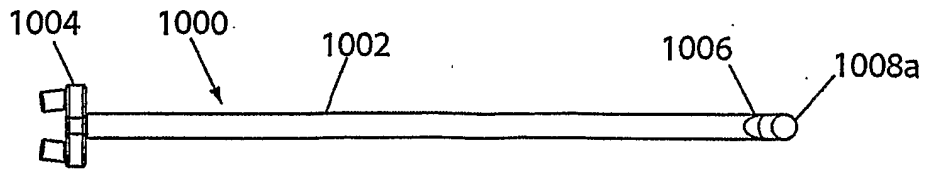

Fig. 8a

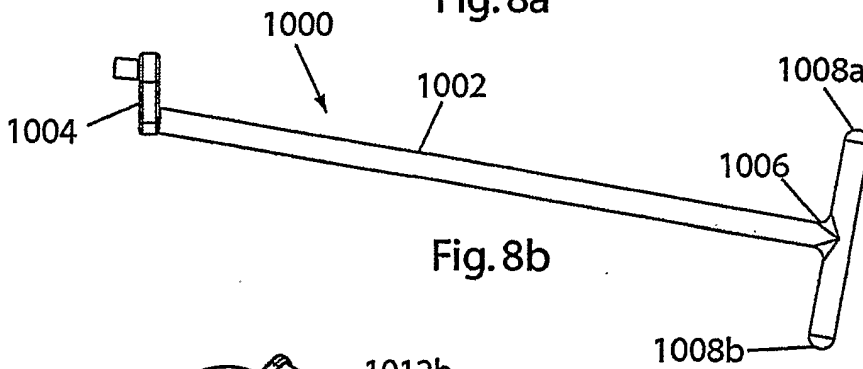

Fig. 8b

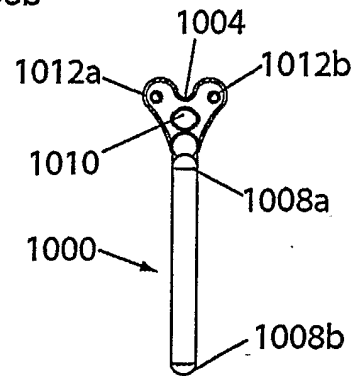
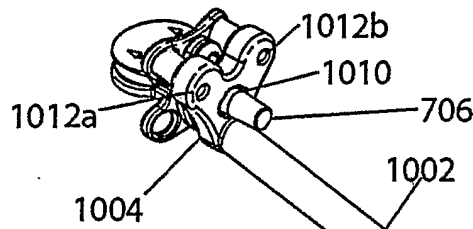

Fig. 8c

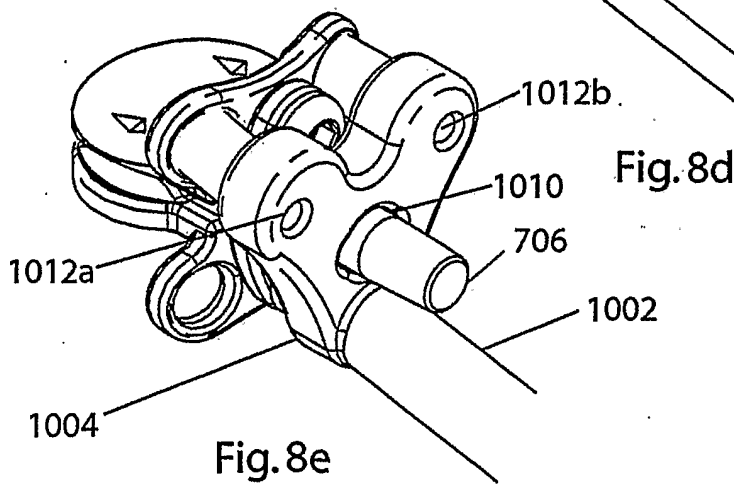

Fig. 8d

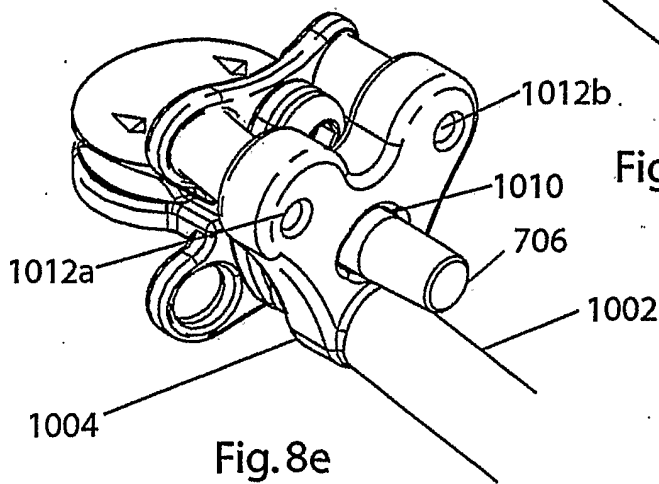

Fig. 8e

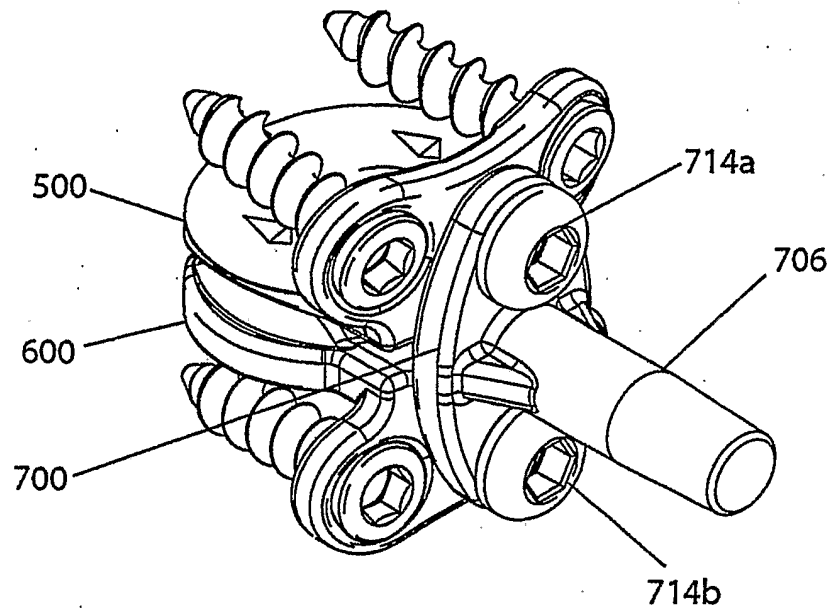

Fig. 9a

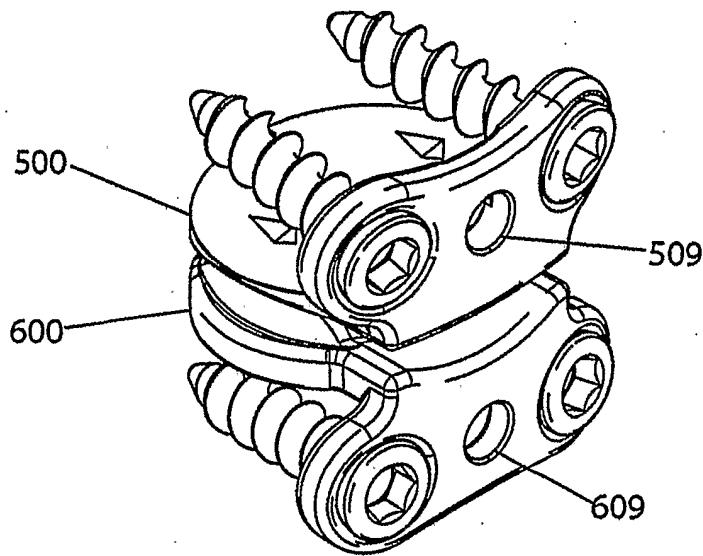

Fig. 9b

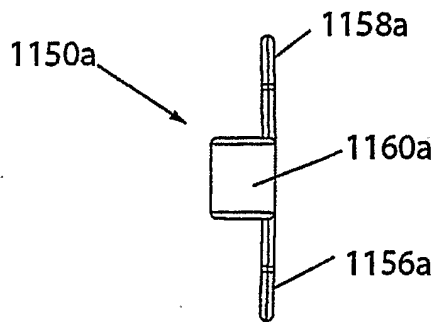

Fig. 10a

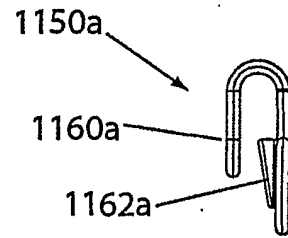

Fig. 10b

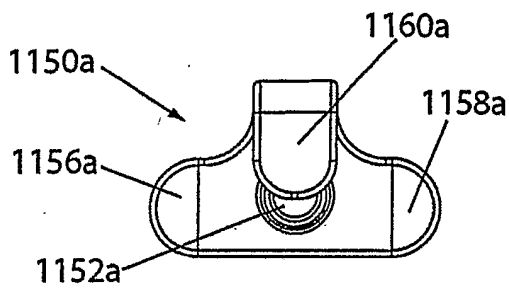

Fig. 10c

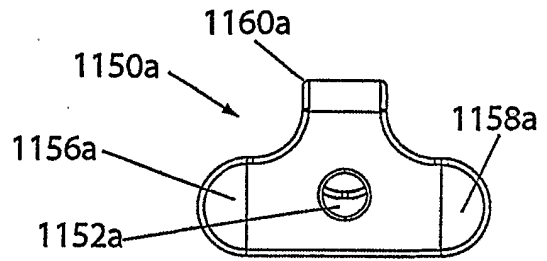

Fig. 10d

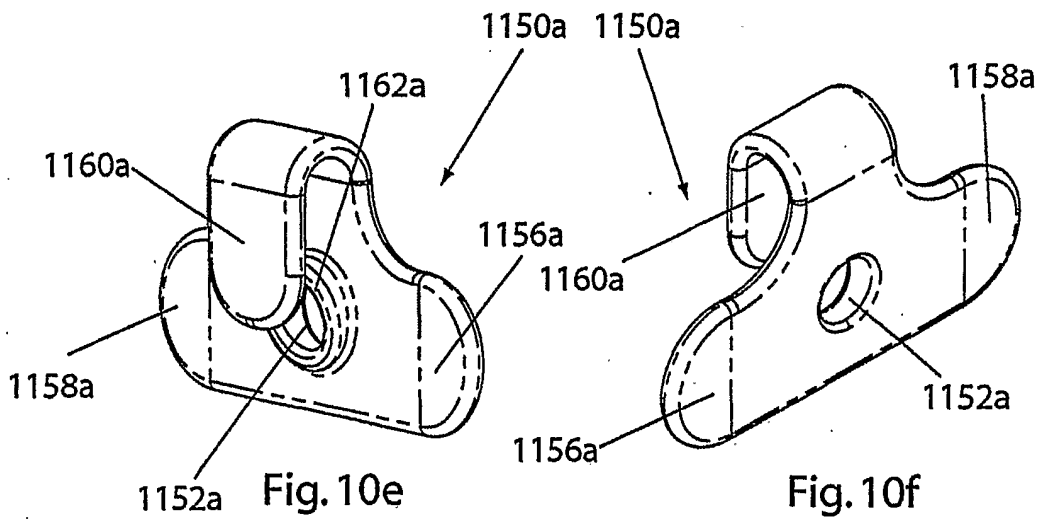

Fig. 10e

Fig. 10f

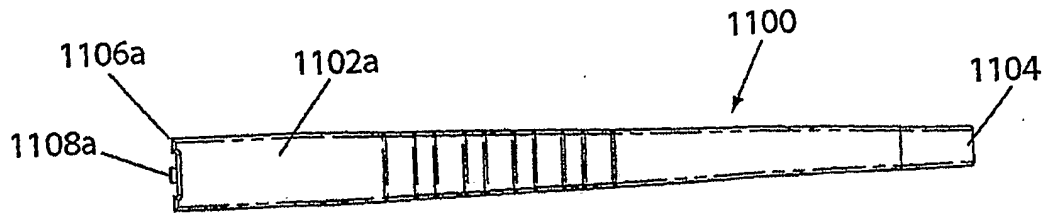

Fig. 11a

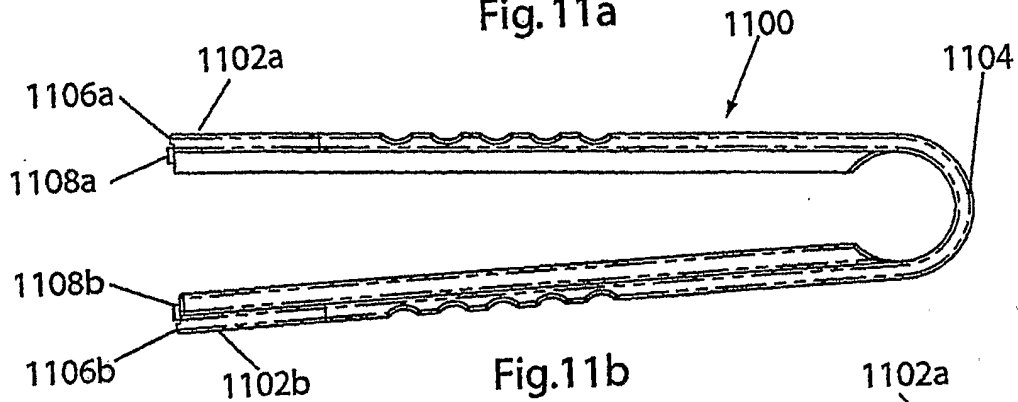

Fig. 11b

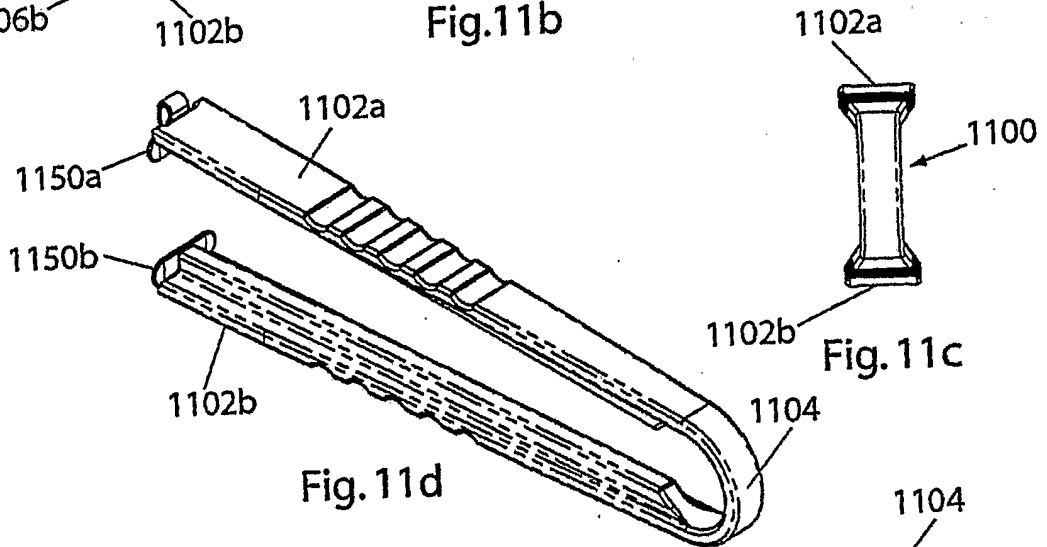

Fig. 11c

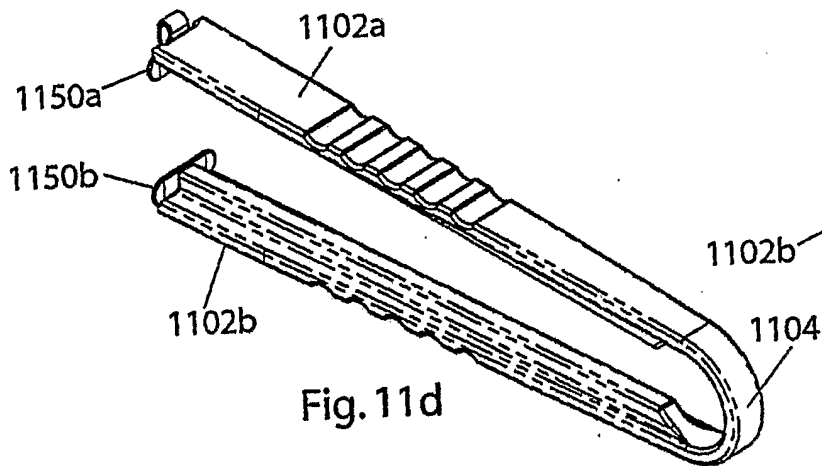

Fig. 11d

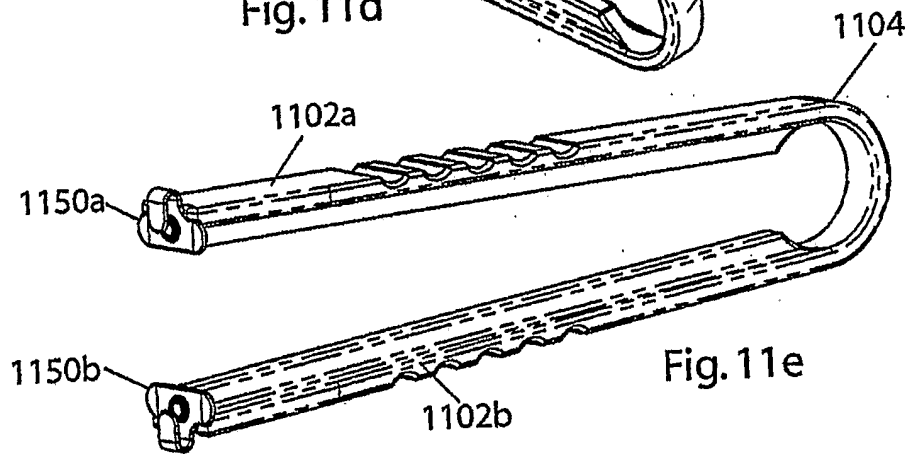
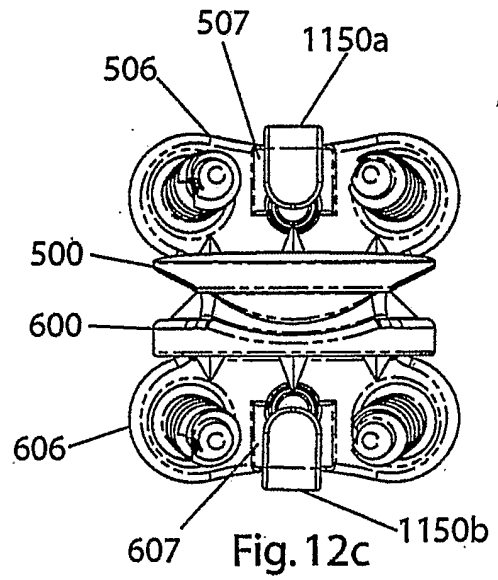
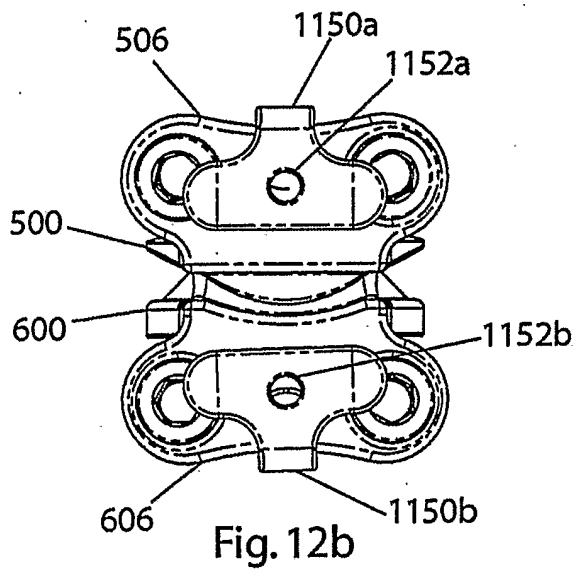
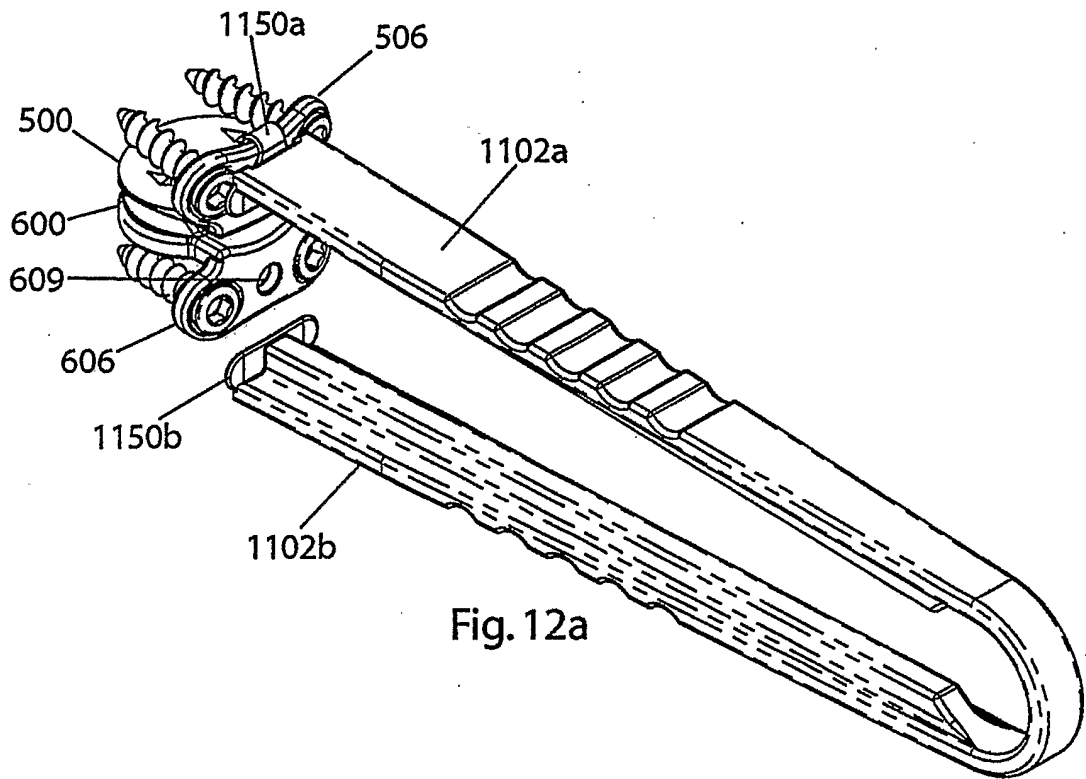

Fig. 11e



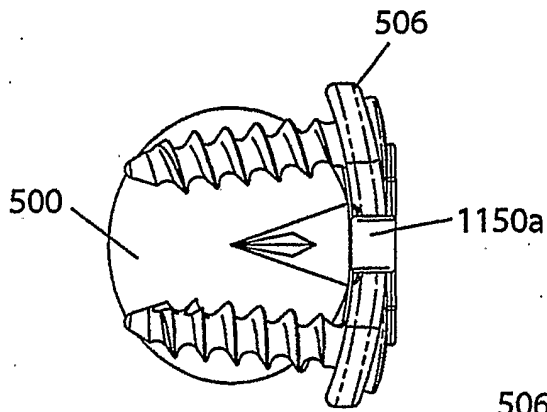

Fig. 12d

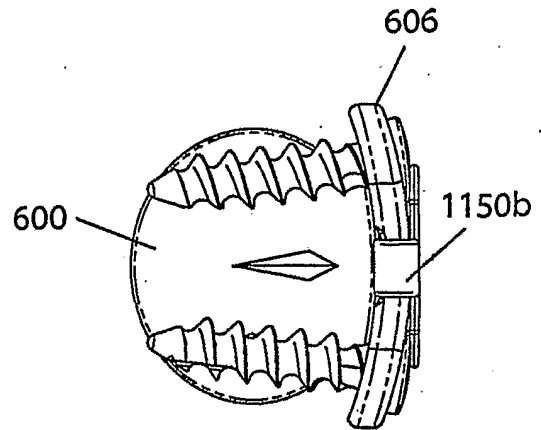

Fig. 12e

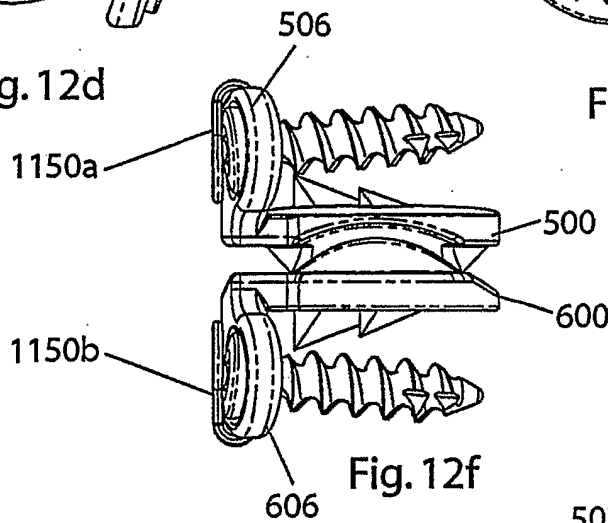

Fig. 12f

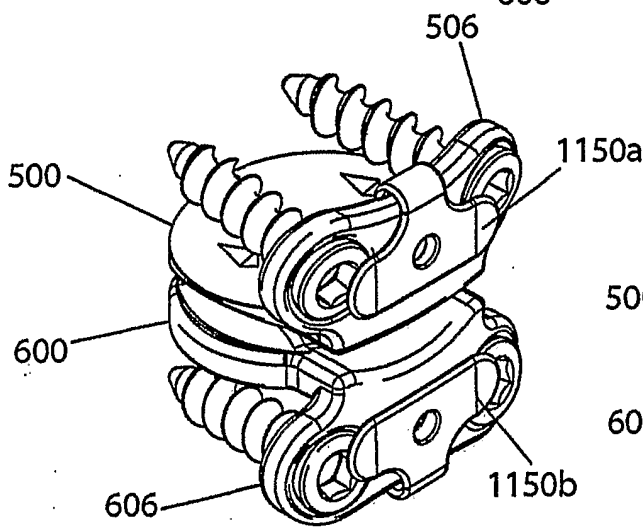

Fig. 12g

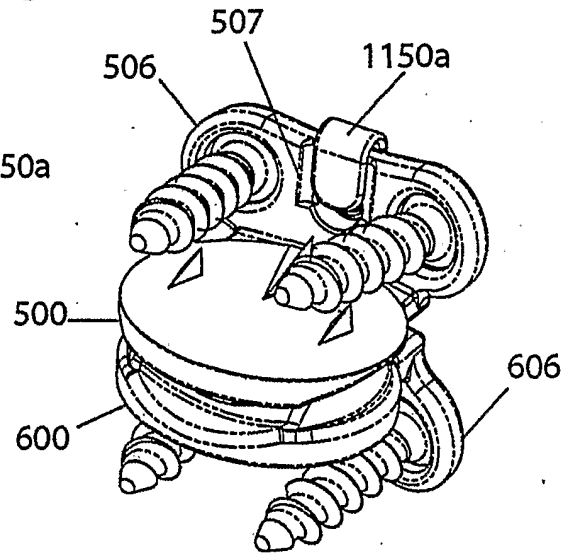

Fig. 12h

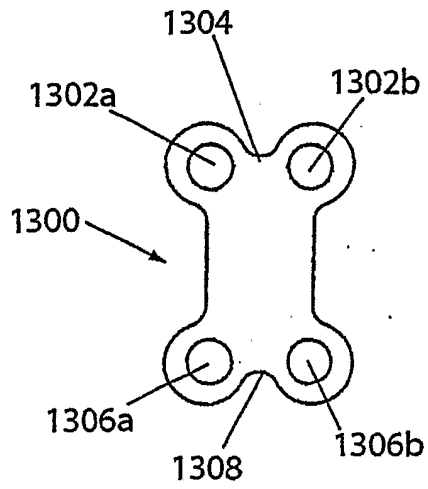

Fig. 13a

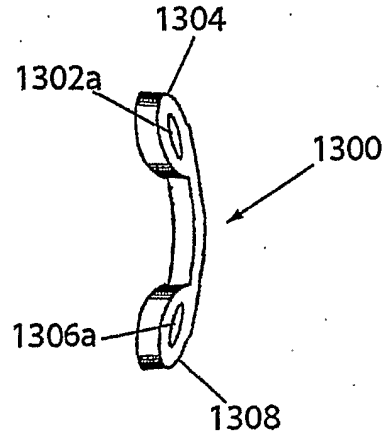

Fig. 13b

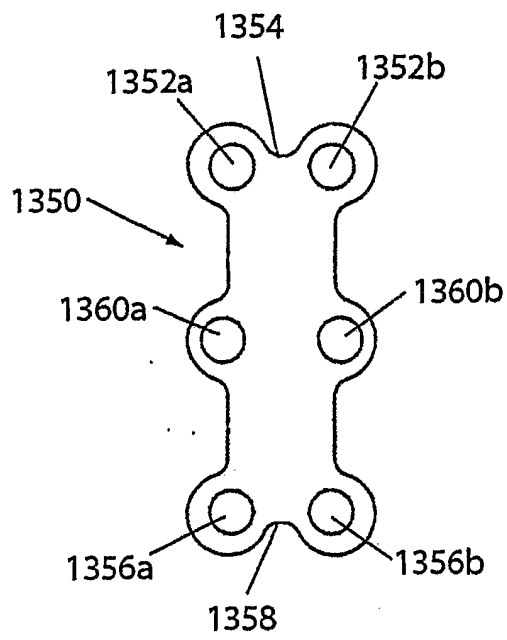

Fig. 13c

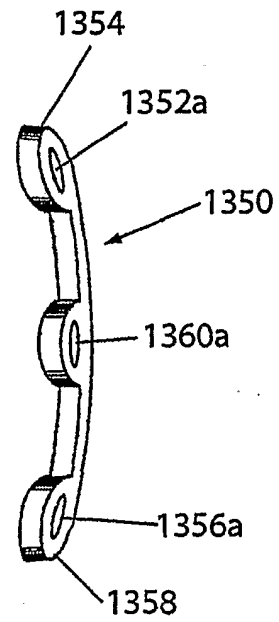
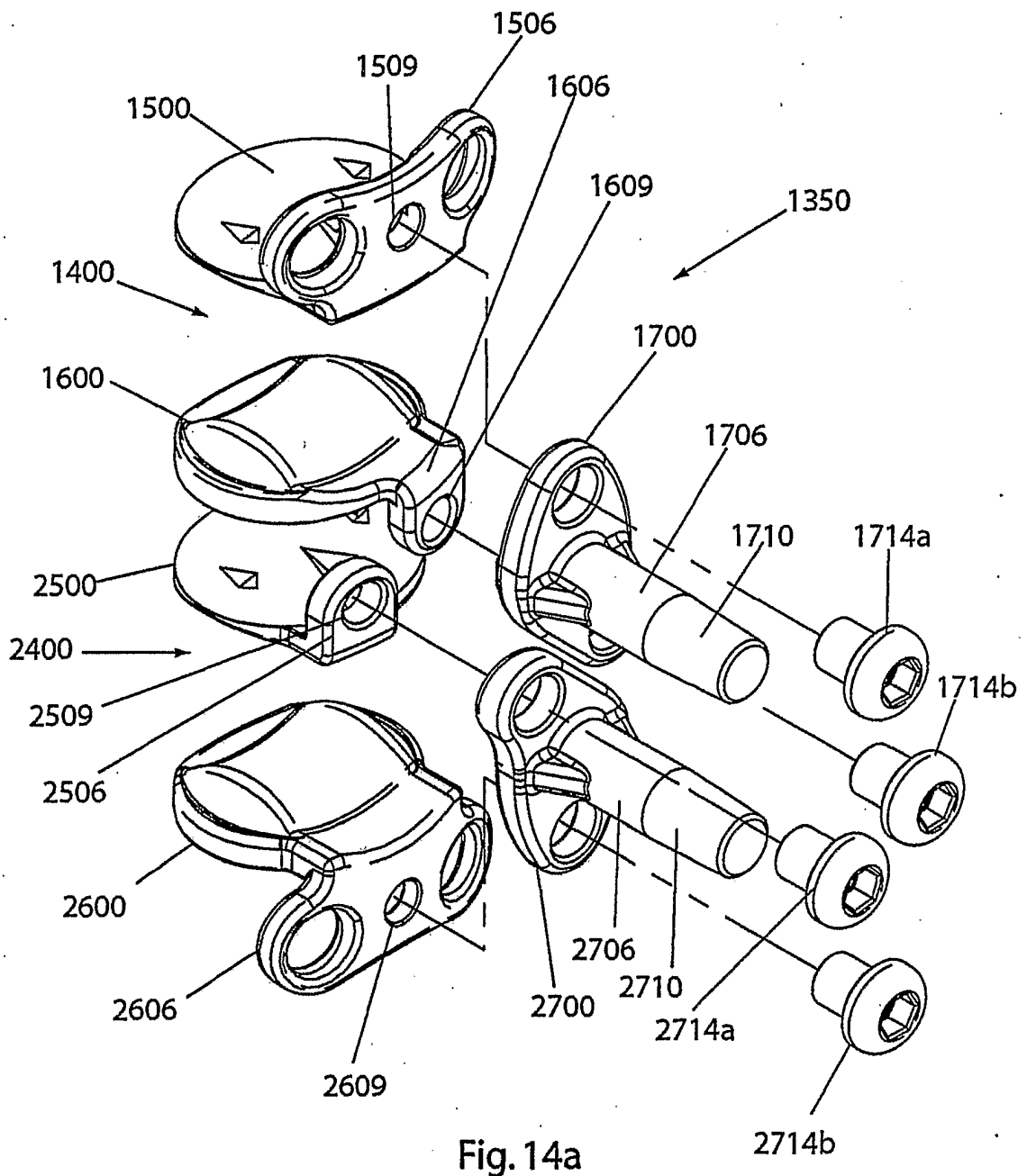

Fig. 13d



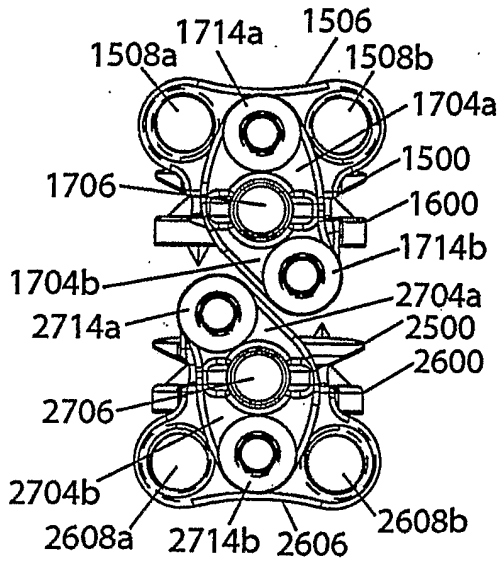

Fig. 14b

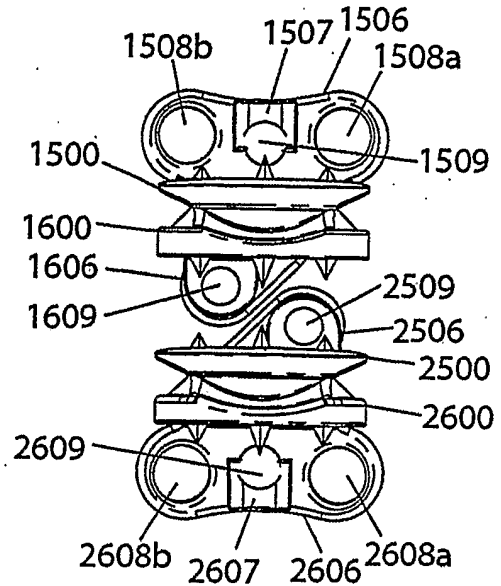

Fig. 14c

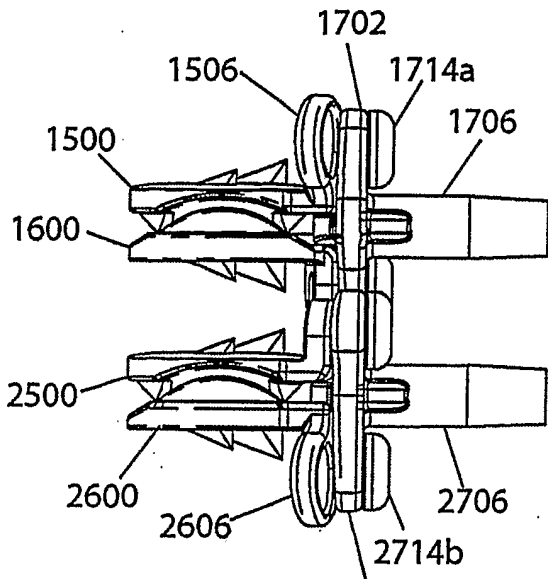

Fig. 14d

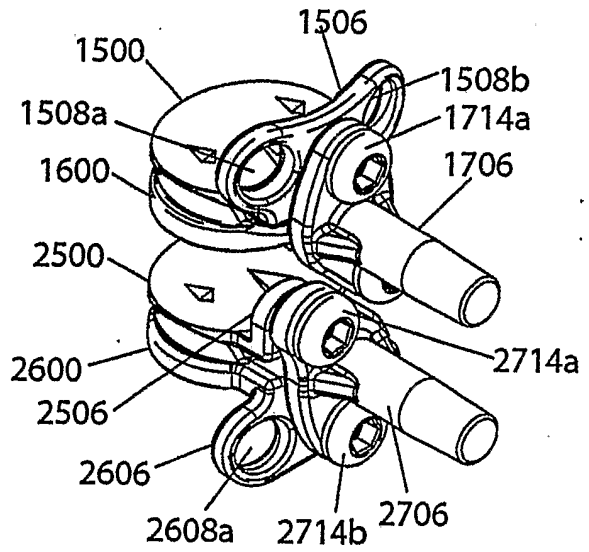
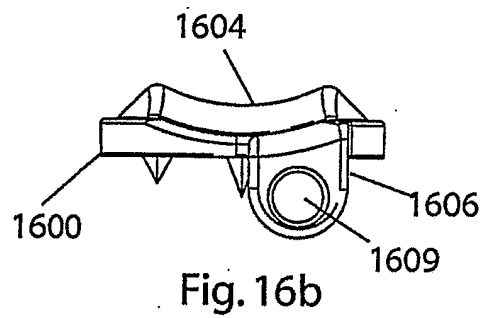
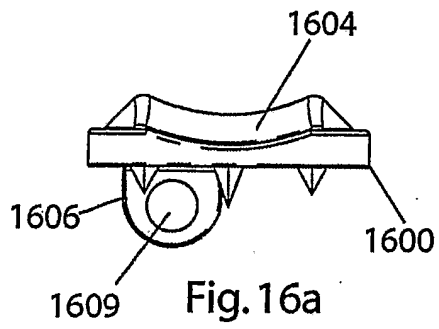
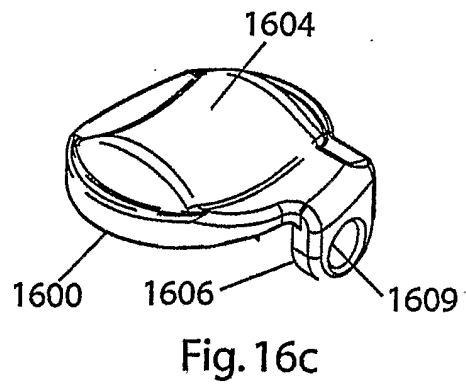
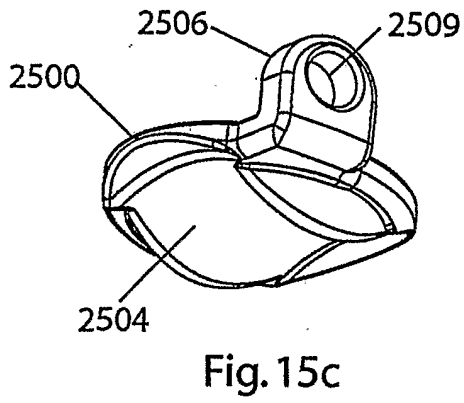
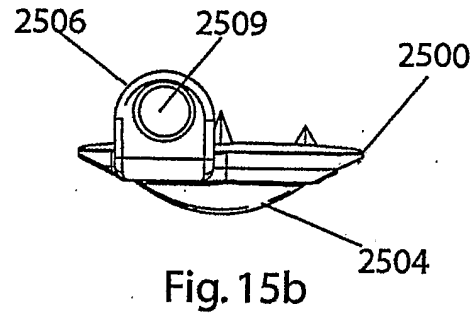
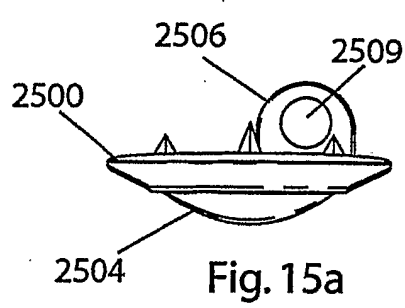

Fig. 14e



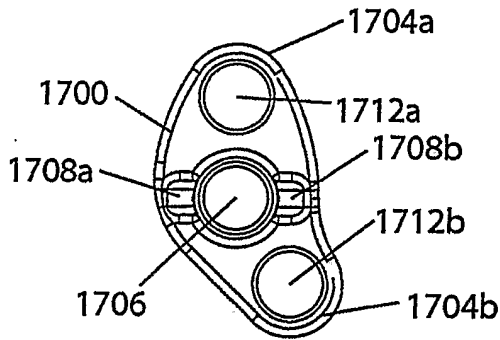

Fig. 17a

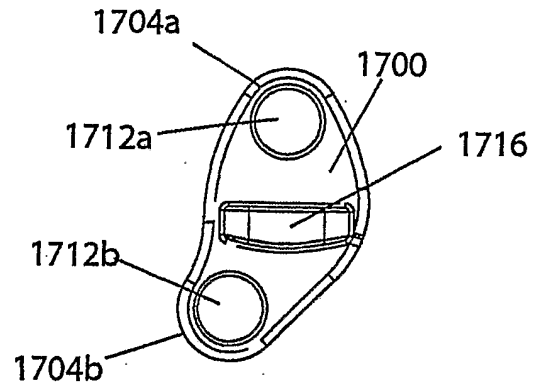

Fig. 17b

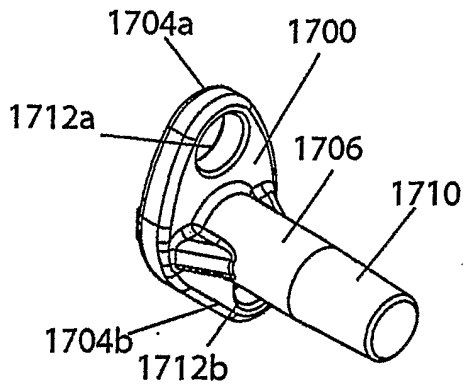

Fig. 17c

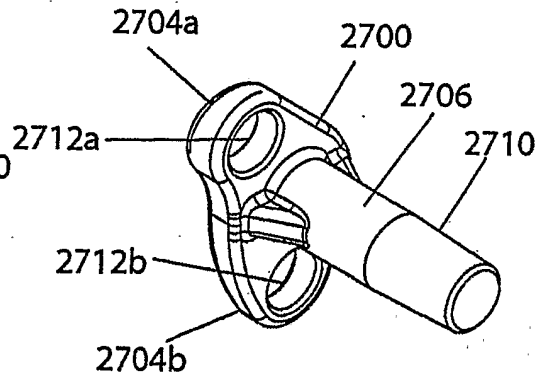

Fig. 18c

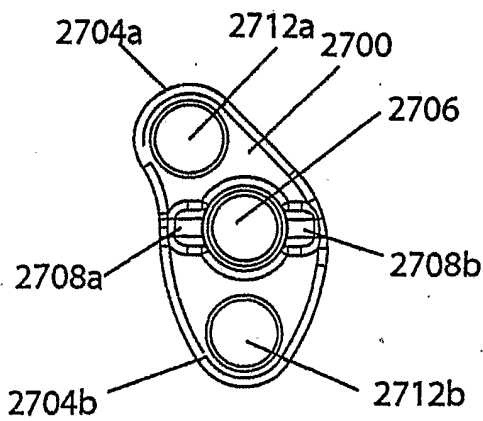

Fig. 18a

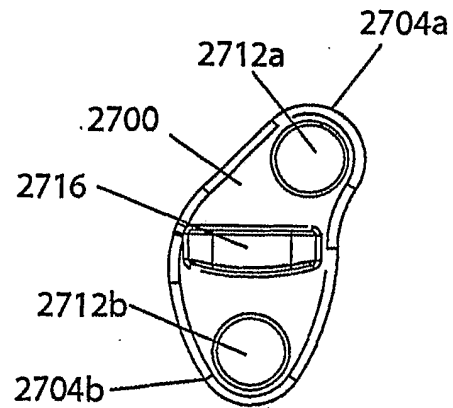

Fig. 18b

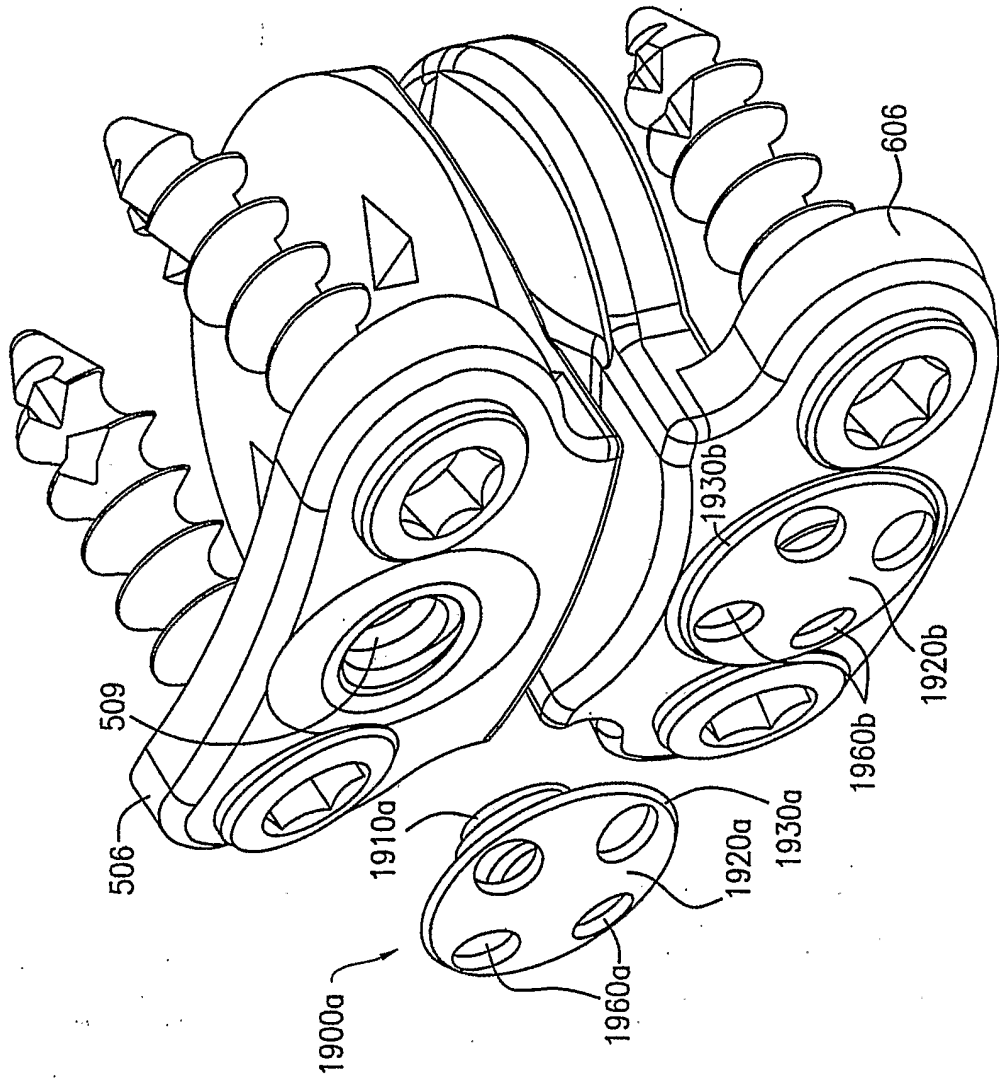

FIG. 19a

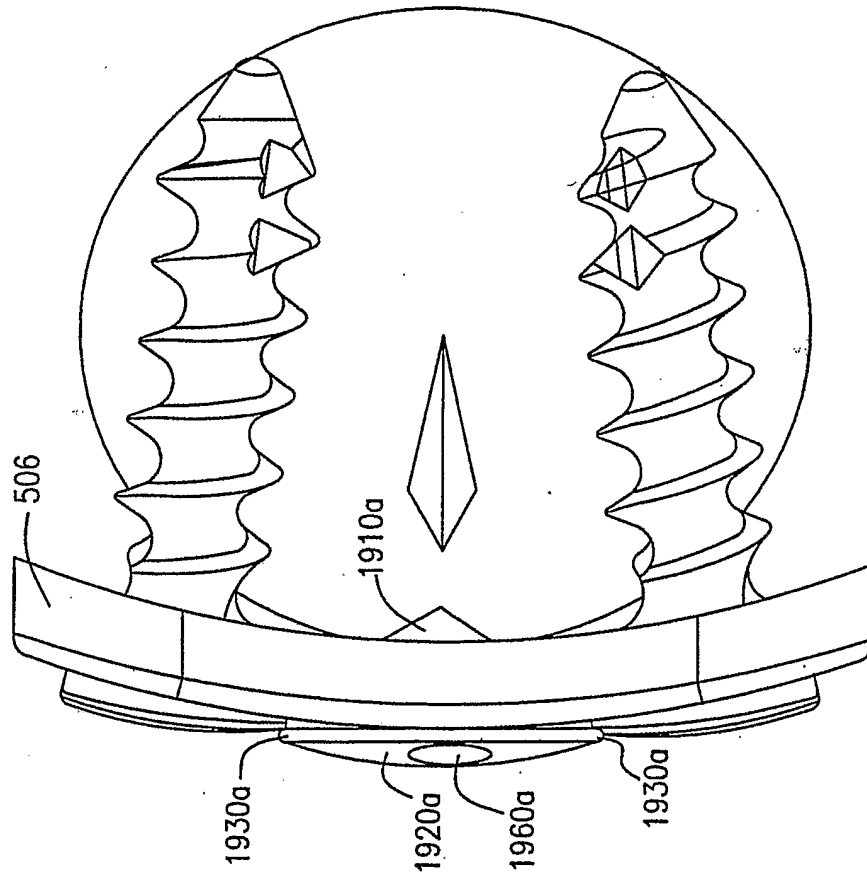

FIG. 19b

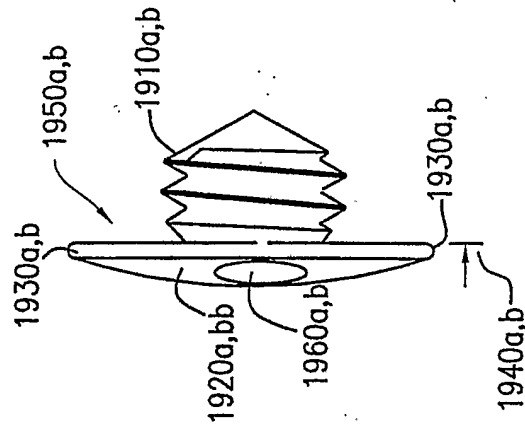

FIG. 19c