

H. GARDINER.  
Car Spring.

No. 109,312.

Patented Nov. 15, 1870.

FIG: 1.

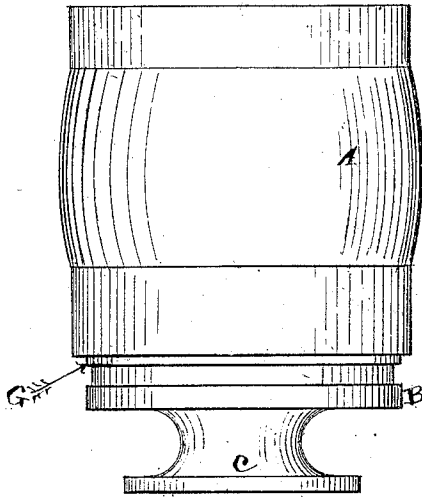
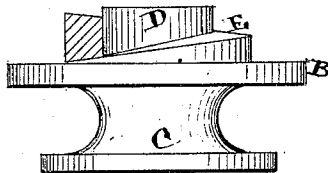
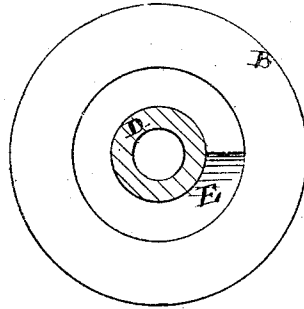
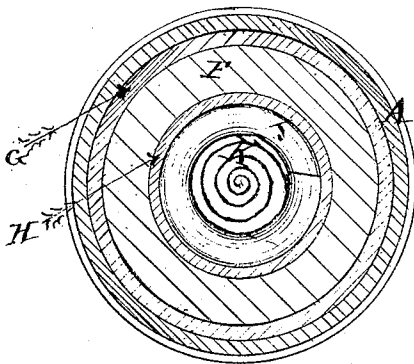
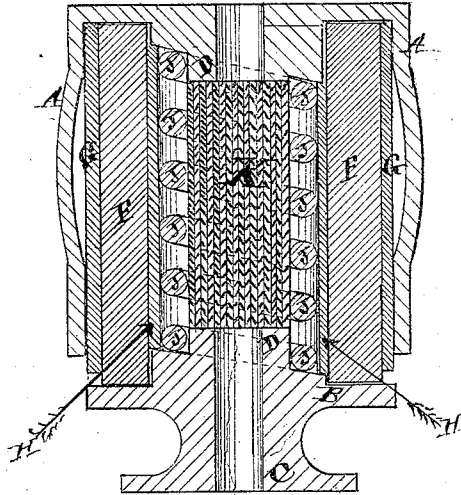

FIG: 2.



*Witnesses*  
Charles L. Paritt  
Franklin Paritt

*Inventor*  
Herman Gardiner

# United States Patent Office.

HEMAN GARDINER, OF NEW YORK, N. Y.

Letters Patent No. 109,312, dated November 15, 1870; antedated November 12, 1870.

## IMPROVEMENT IN RAILWAY-CAR SPRINGS.

The Schedule referred to in these Letters Patent and making part of the same

*To all whom it may concern:*

Be it known that I, HEMAN GARDINER, of the city, county, and State of New York, have invented certain new and useful Improvements in the Construction of Railroad-car Springs; and I do hereby declare that the following is a full description of the same.

The nature of my invention consists—

First, in combining with the rubber and external and internal jacket, or coating or covering of wool or hair, felted cloth, or of any other fibrous fabric of similar properties, for the purpose of isolating the external and internal surfaces of the rubber, from contact with the inner surface of the metal box, and the surface of the spiral spring, and thus prevent the surfaces of the rubber spring from becoming granulated or chafed, as would be the case, if not protected from contact with the rough surfaces of the metal box or the vibratory sides of the spiral spring.

Second, in combining with a spiral spring, a cylindrical roll of felt cloth of wool or hair, or other felted fabric of similar properties, of sufficient length and diameter, when tightly rolled, to fill the core, or central part of the spiral spring, for the purpose of supporting the spiral spring, and, at the same time, in consequence of its formation and confinement within the core of the spiral spring, act as a perpetual elastic force to assist in supporting the load on the car.

But to describe my invention more particularly, I will refer to the accompanying drawing forming a part of this specification, the same letters of reference, wherever they occur, referring to like parts.

Figure 1 is a side view of the spring as it appears when adjusted on the car-truck.

Figure 2 is a vertical cut section of the same.

Figure 3 is a plan or end view of the spring, as seen when the follower or plunger has been removed.

Figure 4 is a view of the inner face of the follower, and also of the inner face of the solid end of the barrel or box in which the springs operate.

Figure 5 is an edge or side view of the follower or plunger.

Letter A represents a metal barrel or box, of about six inches diameter at its ends to the depth of some one to two inches, as required, and about six and one-half inches in diameter at its middle part, and of any suitable length, according to length of springs used.

The object of this formation of the box is, first, by making the middle part of it of greater diameter than its ends, to allow the hollow cylinder of India rubber to expand, and thus, when under pressure, develop an easy and constant elastic force; and, second, by making the ends of the box of a uniform diameter, to the depth of one to two inches, confine the rubber in a vertical position in the box, and, at the same time, act as a guide-way to keep the follower squarely upon the rub-

ber and spiral springs, and thus overcome all tendency to break down the springs at one side more than another, as would be the case if the follower was not rigidly held by the sides of the box in a vertical position.

Letter B is the follower or plunger, having on one side a shank of metal, C, upon which the spring is supported on the car-truck, and on the upper or inner side or face, a center pin, D, encircled by an inclined plane, E.

This device of the center pin and inclined plane is also formed upon the inner face of the solid end or top of the box.

The length and diameter of the center pin are about one inch, but may be varied, according to size and length of spiral spring used.

Letter F represents a hollow cylinder of India rubber, of about the length or the box A, and about one-quarter of an inch less in diameter than its ends. The thickness of the sides of this rubber cylinder is about one inch, more or less, as may be required.

Upon the internal and external sides of this rubber cylinder is secured a jacket or covering of felted cloth, of wool or hair, or other similar fabric or material, as indicated by the letters G and H.

The object of this jacketing the rubber cylinder is, first, for the purpose of preventing the friction of the iron box and spiral spring from chafing the rubber, and thus, by breaking its skin, weaken and destroy its elastic properties, as is well known to be the case with rubber car-springs, when their sides are broken or chafed; and, second, for the purpose of acting as a packing to support the sides of the rubber, and isolate it from direct contact with the sides of the box A and spiral spring J arranged within its center.

This spiral spring is made in the usual way, and of proportionate length to the length of the box A, and of such diameter as to fill the cavity of the rubber cylinder.

Its ends are centered upon the center-pins D, and inclined planes E, as is thus firmly held in a vertical position within the box A.

In the core of the spiral spring is inserted in a columnar form, a roll of felt-cloth, of wool or hair, or other fabric of similar properties, as indicated by letter K. This roll is made by taking a piece or pieces of felt cloth, equal to the length of the spiral spring, and rolling it into a solid cylinder, of sufficient diameter to fill solidly the central part of the spiral spring.

It will be obvious that a roll of felt cloth thus made and confined in the core or central opening of the spiral spring, prevents any possibility of the felt matting, as would be the case if loose wool packing was used; and, at the same time, as the pressure is upon the edges of the several layers of cloth composing the roll, it preserves a constant and durable elastic resisting

force for the center-pins D to act upon, and thus prevents the spiral spring from being fully exhausted of its elastic force, or breaking by being overloaded.

Having now described my invention, I will proceed to set forth what I claim, and desire to secure by Letters Patent of the United States.

I claim—

1. The combination of the hollow cylinder of rubber F with the jackets G and H, for the purposes hereinbefore set forth, and substantially in the mode of application and material used and described.

2. The combination of a cylindrical roll of felt cloth,

of wool, hair, or other similar fabric of like properties, with a coil or spiral spring, substantially as described, and for the purposes set forth.

3. The combination of the barrel A, made as described, with the hollow cylinder of rubber F, isolating felt-cloth jackets G and H, spiral spring J, and roll of felt cloth K, all arranged and operating as described, and for the purposes set forth.

HEMAN GARDINER.

Witnesses:

CHARLES L. BARRITT,  
FRANKLIN BARRITT.