



- (51) **International Patent Classification:**
A61B 18/14 (2006.01) A61B 18/00 (2006.01)
- (21) **International Application Number:**
PCT/US2015/019986
- (22) **International Filing Date:**
11 March 2015 (11.03.2015)
- (25) **Filing Language:** English
- (26) **Publication Language:** English
- (30) **Priority Data:**
14/203,826 11 March 2014 (11.03.2014) US
- (71) **Applicant:** MEDTRONIC ARDIAN LUXEMBOURG S.A.R.L. [LU/US]; 102 rue des Maraichers, L2124 Luxembourg (LU).
- (72) **Inventor:** MAUCH, Kevin; c/o IP Legal Department, Medtronic Vascular Inc., 3576 Unocal Place, Santa Rosa, California 95403 (US).
- (74) **Agents:** KOPCZYNSKI, Jeffie A. et al.; c/o IP Legal Department, Medtronic Vascular Inc., 3576 Unocal Place, Santa Rosa, California 95403 (US).

- (81) **Designated States** (unless otherwise indicated, for every kind of national protection available): AE, AG, AL, AM, AO, AT, AU, AZ, BA, BB, BG, BH, BN, BR, BW, BY, BZ, CA, CH, CL, CN, CO, CR, CU, CZ, DE, DK, DM, DO, DZ, EC, EE, EG, ES, FI, GB, GD, GE, GH, GM, GT, HN, HR, HU, ID, IL, IN, IR, IS, JP, KE, KG, KN, KP, KR, KZ, LA, LC, LK, LR, LS, LU, LY, MA, MD, ME, MG, MK, MN, MW, MX, MY, MZ, NA, NG, NI, NO, NZ, OM, PA, PE, PG, PH, PL, PT, QA, RO, RS, RU, RW, SA, SC, SD, SE, SG, SK, SL, SM, ST, SV, SY, TH, TJ, TM, TN, TR, TT, TZ, UA, UG, US, UZ, VC, VN, ZA, ZM, ZW.
- (84) **Designated States** (unless otherwise indicated, for every kind of regional protection available): ARIPO (BW, GH, GM, KE, LR, LS, MW, MZ, NA, RW, SD, SL, ST, SZ, TZ, UG, ZM, ZW), Eurasian (AM, AZ, BY, KG, KZ, RU, TJ, TM), European (AL, AT, BE, BG, CH, CY, CZ, DE, DK, EE, ES, FI, FR, GB, GR, HR, HU, IE, IS, IT, LT, LU, LV, MC, MK, MT, NL, NO, PL, PT, RO, RS, SE, SI, SK, SM, TR), OAPI (BF, BJ, CF, CG, CI, CM, GA, GN, GQ, GW, KM, ML, MR, NE, SN, TD, TG).

Published:

— with international search report (Art. 21(3))

- (54) **Title:** CATHETERS WITH INDEPENDENT RADIAL-EXPANSION MEMBERS AND ASSOCIATED DEVICES, SYSTEMS, AND METHODS

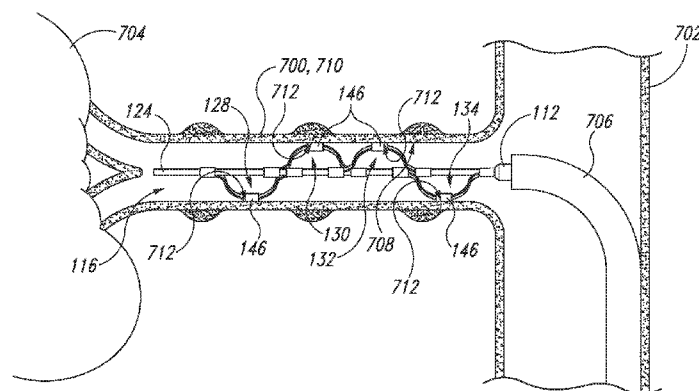
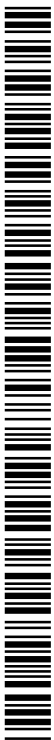

Fig. 7D

- (57) **Abstract:** A neuromodulation catheter includes an elongate shaft and a neuromodulation element operably connected to the shaft. The neuromodulation element includes an elongate support member and a plurality of bow springs operably connected to the support member. The individual bow springs are configured to independently expand radially outward from the support member when the neuromodulation element transitions from a low-profile delivery state to a deployed state at a treatment location within a body lumen. The individual bow springs include a distal leg and a proximal leg and carry an electrode and/or a transducer between their respective distal and proximal legs. The distal and proximal legs of the plurality of bow springs are longitudinally interdigitated. The plurality of bow springs is configured to urge the electrodes and/or the transducers into contact with an inner surface of a wall of the body lumen at a series of contact regions.



CATHETERS WITH INDEPENDENT RADIAL-EXPANSION MEMBERS
AND ASSOCIATED DEVICES, SYSTEMS, AND METHODS

RELATED APPLICATIONS

[0001] This application claims the benefit of United States Non-Provisional Patent Application No. 14/203,826, filed March 11, 2014, the disclosure of which is herein incorporated by reference in its entirety.

TECHNICAL FIELD

[0002] The present technology is related to catheters. In particular, at least some embodiments are related to neuromodulation catheters including neuromodulation elements configured to deliver energy to nerves at or near a treatment location within a body lumen.

BACKGROUND

[0003] The sympathetic nervous system (SNS) is a primarily involuntary bodily control system typically associated with stress responses. Fibers of the SNS extend through tissue in almost every organ system of the human body and can affect characteristics such as pupil diameter, gut motility, and urinary output. Such regulation can have adaptive utility in maintaining homeostasis or in preparing the body for rapid response to environmental factors. Chronic activation of the SNS, however, is a common maladaptive response that can drive the progression of many disease states. Excessive activation of the renal SNS, in particular, has been identified experimentally and in humans as a likely contributor to the complex pathophysiologies of hypertension, states of volume overload (e.g., heart failure), and progressive renal disease.

[0004] Sympathetic nerves of the kidneys terminate in the renal blood vessels, the juxtaglomerular apparatus, and the renal tubules, among other structures. Stimulation of the renal sympathetic nerves can cause, for example, increased renin release, increased sodium reabsorption, and reduced renal blood flow. These and other neural-regulated components of renal function are considerably stimulated in disease states characterized by heightened sympathetic tone. For example, reduced renal blood flow and glomerular filtration rate as a

result of renal sympathetic efferent stimulation is likely a cornerstone of the loss of renal function in cardio-renal syndrome (i.e., renal dysfunction as a progressive complication of chronic heart failure). Pharmacologic strategies to thwart the consequences of renal sympathetic stimulation include centrally-acting sympatholytic drugs, beta blockers (e.g., to reduce renin release), angiotensin-converting enzyme inhibitors and receptor blockers (e.g., to block the action of angiotensin II and aldosterone activation consequent to renin release), and diuretics (e.g., to counter renal sympathetic mediated sodium and water retention). These pharmacologic strategies, however, have significant limitations including limited efficacy, compliance issues, side effects, and others.

BRIEF DESCRIPTION OF THE DRAWINGS

[0005] Many aspects of the present technology can be better understood with reference to the following drawings. The components in the drawings are not necessarily to scale. Instead, emphasis is placed on illustrating clearly the principles of the present technology. For ease of reference, throughout this disclosure identical reference numbers may be used to identify identical or at least generally similar or analogous components or features.

[0006] FIG. 1A is a perspective view of a system including a catheter, console and cable configured in accordance with an embodiment of the present technology. The catheter includes an elongated shaft and a therapeutic element operably connected to the shaft.

[0007] FIGS. 1B and 1C are an enlarged side view and an enlarged perspective view, respectively, of the therapeutic element shown in FIG. 1A.

[0008] FIGS. 2A and 2B are side views of a radial-expansion member and an associated segment of a support member of the therapeutic element shown in FIGS. 1A-1C. In FIG. 2A, the radial-expansion member is shown in a radially expanded state. In FIG. 2B, the radial-expansion member is shown in a radially constrained state.

[0009] FIG. 2C is an enlarged cross-sectional view of the therapeutic element shown in FIG. 1A taken along the line 2C-2C in FIG. 2A.

[0010] FIGS. 2D and 2E are enlarged cross-sectional views of therapeutic elements of catheters configured in accordance with additional embodiments of the present technology taken along transverse planes similar to the plane corresponding to the line 2C-2C in FIG. 2A.

[0011] FIGS. 3A and 3B are side views of a radial-expansion member and an associated segment of a support member of a therapeutic element of a catheter configured in accordance with another embodiment of the present technology. In FIG. 3A, the radial-expansion member is shown in a radially expanded state. In FIG. 3B, the radial-expansion member is shown in a radially constrained state.

[0012] FIGS. 4A and 4B are side views of a radial-expansion member and an associated segment of a support member of a therapeutic element of a catheter configured in accordance with another embodiment of the present technology. In FIG. 4A, the radial-expansion member is shown in a radially expanded state. In FIG. 4B, the radial-expansion member is shown in a radially constrained state.

[0013] FIGS. 5 and 6 are perspective views of therapeutic elements of catheters configured in accordance with additional embodiments of the present technology.

[0014] FIGS. 7A–7D are enlarged anatomical side views of the therapeutic element shown in FIG. 1A and associated components located at a treatment location within a renal artery. In FIG. 7A, the therapeutic element is in a low-profile delivery state within a sheath. In FIG. 7B, the therapeutic element is shown in a first intermediate state as the therapeutic element transitions from the delivery state to a deployed state. In FIG. 7C, the therapeutic element is shown in a second intermediate state as the therapeutic element transitions from the first intermediate state to the deployed state. In FIG. 7D, the therapeutic element is shown in the deployed state.

[0015] FIG. 8 is an enlarged anatomical side view of the therapeutic element shown in FIG. 1A in a deployed state and located at a treatment location within a lumen segment including an obstruction.

[0016] FIG. 9 is an enlarged anatomical side view of the therapeutic element shown in FIG. 1A in a deployed state and located at a treatment location within a non-uniform lumen segment.

[0017] FIGS. 10A and 10B are cross-sectional side views of a series of radial-expansion members and an associated segment of a support member of a therapeutic element of a catheter configured in accordance with another embodiment of the present technology. In FIG. 10A, the radial-expansion members are shown in radially constrained states. In FIG. 10B, the radial-expansion member are shown in radially expanded states.

DETAILED DESCRIPTION

[0018] The present technology is related to catheters, such as catheters including neuromodulation elements configured to deliver energy to nerves at or near a treatment location within a body lumen. More specifically, catheters configured in accordance with at least some embodiments of the present technology are expected to treat tissue (e.g., nerves) at or near treatment locations within geometrically irregular (e.g., curved and/or non-cylindrical) segments of body lumens in a reliable and consistent manner. With at least some conventional catheters, geometrical irregularities (e.g., curves, narrowings, and asymmetries, among other examples) of body lumens may complicate the reliable and consistent formation of desirable treatment profiles. For example, in many neuromodulation treatments, it is desirable to form a helical lesion or pattern of lesions, which may allow substantially all nerves around the circumference of a body lumen to be modulated without forming a potentially problematic fully circumferential lesion in any single transverse plane. Other examples of desirable treatment profiles may be non-helical.

[0019] Known types of neuromodulation catheters suitable for forming helical lesions or patterns of lesions include a therapeutic element having a resilient or otherwise expandable structure carrying a plurality of electrodes and may be capable of reliably achieving complete deployment within a cylindrical body lumen. In some cases, however, the desired or target body lumen may not be cylindrical. For example, renal neuromodulation can include modulating nerves at or near treatment locations within renal arteries, which are often relatively short and tortuous. When a therapeutic element of a neuromodulation catheter is deployed at a treatment location within a lumen segment that is non-cylindrical (e.g., not straight and/or having an inconsistent cross-sectional area in successive transverse planes), it may be challenging to reliably attain complete deployment of the therapeutic element and thereby achieve simultaneous, stable, and/or otherwise therapeutically effective contact between electrodes carried by the therapeutic element and an inner surface of a wall of a body lumen.

[0020] When a therapeutic element is not completely deployed, energizing an electrode carried by the therapeutic element may form an incomplete lesion, such as a lesion that does not penetrate the wall of the body lumen deeply enough to modulate the sympathetic nerve(s) proximate the electrode. To improve the likelihood of forming a complete lesion, a clinician may reposition the therapeutic element until complete deployment of the therapeutic element

is achieved, as may be indicated by adequate impedance measured through the electrode. Alternatively, a clinician may compensate for incomplete deployment by forming multiple lesions at different positions on the body lumen. Each of these options is time consuming and may increase the risk of undesirable complications. Furthermore, incomplete deployment of a therapeutic element may go undetected and diminish the therapeutic effect of a neuromodulation treatment.

[0021] Neuromodulation catheters configured in accordance with embodiments of the present technology can at least partially address one or more of the problems described above and/or other problems associated with known neuromodulation technologies whether or not stated herein. For example, a neuromodulation catheter configured in accordance with a particular embodiment includes an elongate shaft and a therapeutic element operably connected to the shaft. The therapeutic element includes an elongate support member and a plurality of radial-expansion members operably connected to the support member. The individual radial-expansion members each carry an electrode and are configured to independently expand radially outward from the support member when the therapeutic elements each transition from a low-profile delivery state to a deployed state at a treatment location within a body lumen. The plurality of radial-expansion members is configured to urge the electrodes into contact with an inner surface of a wall of the lumen segment at a series of longitudinally and circumferentially spaced-apart contact regions. The relative independence of the radial expansion of a given radial-expansion member relative to other radial-expansion members on the catheter and/or other features of the neuromodulation catheter may facilitate reliably achieving complete deployment of the therapeutic element. For example, when the therapeutic element is deployed at a treatment location within a lumen segment that is not straight and/or has an inconsistent cross-sectional area in successive transverse planes, the effect of these anatomical characteristics can be localized.

[0022] Specific details of several embodiments of the present technology are described herein with reference to FIGS. 1A-10B. Although many of the embodiments are described herein with respect to devices, systems, and methods for percutaneous intravascular renal neuromodulation, other applications and other embodiments in addition to those described herein are within the scope of the present technology. For example, at least some embodiments may be useful for neuromodulation within a body lumen other than a blood vessel, for extravascular neuromodulation, for non-renal neuromodulation, and/or for use in

therapies other than neuromodulation. It should be noted that other embodiments in addition to those disclosed herein are within the scope of the present technology. Furthermore, embodiments of the present technology can have different configurations and components, and may be used for procedures different from those disclosed herein. Moreover, a person of ordinary skill in the art will understand that embodiments of the present technology can have configurations, components, and/or procedures in addition to those disclosed herein and that these and other embodiments can be without several of the configurations, components, and/or procedures disclosed herein without deviating from the present technology.

[0023] As used herein, the terms "distal" and "proximal" define a position or direction with respect to a clinician or a clinician's control device (e.g., a handle of a catheter). The terms, "distal" and "distally" refer to a position distant from or in a direction away from a clinician or a clinician's control device. The terms "proximal" and "proximally" refer to a position near or in a direction toward a clinician or a clinician's control device. The headings provided herein are for convenience only and should not be construed as limiting the subject matter disclosed.

Selected Examples of Neuromodulation Catheters and Related Devices

[0024] FIG. 1A is a perspective view of a system 100 (e.g., a neuromodulation system) configured in accordance with an embodiment of the present technology. The system 100 can include a catheter 102 (e.g., a neuromodulation catheter), a console 104, and a cable 106 extending therebetween. The catheter 102 can include an elongate shaft 108 having a proximal end portion 110 and a distal end portion 112. The catheter 102 can further include a handle 114 and a therapeutic element 116 (e.g., a neuromodulation element) operably connected to the shaft 108 via, respectively, the proximal and distal end portions 110, 112 of the shaft 108. The shaft 108 can be configured to locate the therapeutic element 116 intravascularly at a treatment location within a body lumen, such as a suitable blood vessel, duct, airway, or other naturally occurring lumen within the human body. The therapeutic element 116 can be configured to provide or support a treatment (e.g., a neuromodulation treatment) at the treatment location.

[0025] Therapeutic element 116 can be configured to be radially constrained and slidably disposed within a delivery sheath (see FIGS. 7A-7D) while the catheter 102 is being deployed within a body lumen. The outside diameter of the sheath can be 2, 3, 4, 5, 6, or 7

French or another suitable size. As an example, deployment of the catheter 102 can include percutaneously inserting a medical guide wire (not shown) into a body lumen of a patient and advancing the catheter 102 along the guide wire until the therapeutic element 116 reaches a suitable treatment location. As another example, the catheter 102 can be steerable or non-steerable and configured for deployment without a guide wire. Catheter 102 can also be configured for deployment via a guide catheter (not shown) with or without the use of a delivery sheath or guide wire.

[0026] The console 104 can be configured to control, monitor, supply energy, and/or otherwise support operation of the catheter 102. Alternatively, the catheter 102 can be self-contained or otherwise configured for operation without connection to a console 104. When present, the console 104 can be configured to generate a selected form and/or magnitude of energy for delivery to tissue at or near a treatment location via the therapeutic element 116. The console 104 can have different configurations depending on the treatment modality of the catheter 102. When the catheter 102 is configured for electrode-based, heat-element-based, or transducer-based treatment, for example, the console 104 can include an energy generator (not shown) configured to generate radio frequency (RF) energy (e.g., monopolar and/or bipolar RF energy), pulsed electrical energy, microwave energy, optical energy, ultrasound energy (e.g., intravascularly delivered ultrasound energy, extracorporeally delivered ultrasound energy, and/or high-intensity focused ultrasound energy), direct heat, radiation (e.g., infrared, visible, and/or gamma radiation), and/or another suitable type of energy. Similarly, when the catheter 102 is configured for chemical-based treatment (e.g., drug infusion), the console 104 can include a chemical reservoir (not shown) and can be configured to supply the catheter 102 with one or more chemicals.

[0027] In some embodiments, the system 100 includes a control device 118 along the cable 106. The control device 118 can be configured to initiate, terminate, and/or adjust operation of one or more components of the catheter 102 directly and/or via the console 104. In other embodiments, the control device 118 can be absent or can have another suitable location, such as within the handle 114. The console 104 can be configured to execute an automated control algorithm 120 and/or to receive control instructions from an operator. Furthermore, the console 104 can be configured to provide information to an operator before, during, and/or after a treatment procedure via an evaluation/feedback algorithm 122.

[0028] FIGS. 1B and 1C are an enlarged side view and an enlarged perspective view, respectively, of the therapeutic element 116. The therapeutic element 116 can include an elongate support member 124 and a plurality of radial-expansion members 126 operably connected to the support member 124 in a distal-to-proximal sequence. In the illustrated embodiment, the plurality of radial-expansion members 126 includes a first radial-expansion member 128, a second radial-expansion member 130, a third radial-expansion member 132, and a fourth radial-expansion member 134. It will be appreciated, however, that in other embodiments the therapeutic element 116 may include a different number of individual radial-expansion members 126 (e.g., another suitable number less than 10 or a suitable number greater than 10). The individual radial-expansion members 126 can include a distal end portion 136 (e.g., a distal leg) and a proximal end portion 138 (e.g., a proximal leg). One or both of the distal and proximal end portions 136, 138 of the individual radial-expansion members 126 can be moveably (e.g., slidably) connected to the support member 124. Disposed between their respective distal and proximal end portions 136, 138, the individual radial-expansion members 126 can include a bridging portion 140 configured to expand radially outward from the support member 124 in conjunction with the corresponding distal end portion 136 moving proximally toward the corresponding proximal end portion 138 and/or the corresponding proximal end portion 138 moving distally toward the corresponding distal end portion 136.

[0029] In the illustrated embodiment, the distal end portions 136 of the individual radial-expansion members 126 include a longitudinally slidable collar 142 mounted about support member 124. The proximal end portions 138 of the individual radial-expansion members 126 include a fixed collar 144 mounted about support member 124. Collars 142, 144 can extend fully or partially around support member 124 or may be replaced with other suitable connecting structures. Also In the illustrated embodiment, individual radial-expansion members each 126 carry an annular electrode 146 at their respective bridging portions 140 and include an electrical lead (not shown) extending along or through their respective proximal end portions 138. In other embodiments, radial-expansion members 126 can include other suitable types and/or positions of electrodes 146 and associated leads. For example, resilient members 126 can be electrically conductive, with bridging portions 140 serving as electrodes and proximal end portions 138 serving as electrical leads. In still other embodiments, individual radial-expansion members 126 can include treatment elements other

than electrodes, such as devices suitable for providing other energy-based or chemical-based treatment modalities.

[0030] The individual radial-expansion members 126 can be configured to independently expand radially outward from the support member 124 when the therapeutic element 116 transitions from a low-profile delivery state to a deployed state. For example, the individual radial-expansion members 126 can be resiliently biased to move their respective bridging portions 140 radially outward from the support member 124 when each radial-expansion member 126 is released from the inward radial constraint provided by a delivery sheath. Furthermore, the individual radial-expansion members 126 can be configured to self-expand from a radially constrained, stressed condition in the low-profile delivery state to a radially expanded, relaxed condition at a predetermined extent of radial expansion in the deployed state. The plurality of radial-expansion members 126 can be arranged along support member 124 to urge the electrodes 146 into contact with an inner surface of a lumen wall (not shown) at a series of contact regions when the therapeutic element 116 is in the deployed state at a treatment location within a body lumen having the lumen wall. In this way, the therapeutic element 116 can form a desirable treatment profile. For example, the contact regions can be longitudinally and circumferentially spaced apart and, in at least some cases, disposed along a helical path.

[0031] Individual radial-expansion members 126 partially overlap longitudinally. For example, the distal and proximal end portions 136, 138 of the plurality of radial-expansion members 126 can be interdigitated and/or the individual radial-expansion members 126 can be longitudinally staggered, nested, and/or interrelated in another suitable manner. This can be useful, for example, to facilitate independent expansion of the individual radial-expansion members 126 without unduly sacrificing longitudinal compactness. The distal end portions 136 of the individual radial-expansion members 126 can be operably connected to the support member 124 at positions between positions at which the distal and proximal end portions 136, 138 of a distally adjacent radial-expansion member 126 (if present) are operably connected to the support member 124. For example, the distal end portions 136 of the individual radial-expansion members 126 can be fixedly connected to or longitudinally slidable along segments of the support member 124 between distal and proximal end portions 136, 138 of a distally adjacent radial-expansion member 126 (if present). Similarly, the proximal end portions 138 of the individual radial-expansion members 126 can be operably

connected to the support member 124 at positions between positions at which the distal and proximal end portions 136, 138 of the proximally adjacent radial-expansion member 126 (if present) are operably connected to the support member 124. For example, the proximal end portions 138 of the individual radial-expansion members 126 can be fixedly connected to or longitudinally slidable along segments of the support member 124 between distal and proximal end portions 136, 138 of a proximally adjacent radial-expansion member 126 (if present).

[0032] In the illustrated embodiment, the individual radial-expansion members 126 include a bow-shaped ribbon 148 made of metal (e.g., spring tempered stainless steel or titanium nickel alloy commonly known as nitinol) and having sigmoid, i.e. C-shaped, or bell-shaped portions 150 with opposite orientations at opposite sides of the bridging portion 140. In other embodiments, the radial-expansion members 126 can have other forms suitable for radial expansion to place bridging portions 140 in apposition with the inner wall of a body lumen. For example, the individual radial-expansion members 126 can include a wire (not shown) in place of the ribbon 148. As another example, the individual radial-expansion members 126 can each include a tubular structure (not shown) in place of the ribbon 148, such as to facilitate routing electrical leads from the support member 124 to the electrodes 146. As yet another example, the individual radial-expansion members 126 can include resiliency-enhancing structural features (not shown), such as compact helical or sinusoidal bends along all or a portion of the length of the ribbon 148. As yet another example, the overall shape of the individual radial-expansion members 126 can be angular rather than curved. Other suitable variations in the characteristics of the individual radial-expansion members 126 are also possible.

[0033] FIGS. 2A and 2B are side views of the second radial-expansion member 130 and an associated segment of the support member 124 with the other radial-expansion members 126 omitted for clarity of illustration. In FIG. 2A, the second radial-expansion member 130 is shown in a radially extended state. In FIG. 2B, the second radial-expansion member 130 is shown in a radially constrained state. As illustrated in FIGS. 2A and 2B, the second radial-expansion member 130 can be configured to move between the extended and constrained states by longitudinal movement of the distal end portion 136 along support member 124 while the proximal end portion 138 remains fixed to support member 124. This can be useful, for example, to facilitate smooth transitioning of the therapeutic element 116 from the

deployed state to the low-profile delivery state as the therapeutic element 116 is retracted into a sheath (not shown), such as by reducing or eliminating catching of the radial-expansion members 126 on a distal lip of the sheath.

[0034] FIG. 2C is an enlarged cross-sectional view of the therapeutic element 116 taken along the line 2C-2C in FIG. 2A. As illustrated in FIG. 2C, the slidable collar 142 can be configured to slide along an exterior surface of a segment of the support member 124. FIGS. 2D and 2E are enlarged cross-sectional views of therapeutic elements of catheters configured in accordance with additional embodiments of the present technology taken along transverse planes similar to the plane corresponding to the line 2C-2C in FIG. 2A. As shown in FIG. 2D, in some embodiments, a distal end portion 200 of a radial-expansion member (not separately identified in FIG. 2D) includes a slidable collar 202 that has a non-circular inner surface in a transverse plane. The slidable collar 202 and a corresponding outer surface 206 of a support member 208 can be keyed. As shown in FIG. 2E, in other embodiments, a distal end portion 250 of a radial-expansion member (not separately identified in FIG. 2E) includes an enlarged head 252 slidably disposed within a channel 254 defined by a support member 256. The channel 254 can be a common channel that receives heads 252 of distal end portions 250 of multiple radial-expansion members (not shown) or a discrete channel that receives only the head 252 shown in FIG. 2E. In the latter case, the channel 254 can be one of a plurality of channels that individually receive different heads 252.

[0035] Features of the embodiments shown in FIGS. 2D and 2E may restrict circumferential, e.g. rotational movement of the slidable collars 142, 202 relative to respective support members 208, 256. This can be useful, for example, when it is desirable to maintain precise radial orientations of the distal end portions 200, 250, respectively. As another potential advantage, features of the embodiments shown in FIGS. 2D and 2E that restrict rotational movement of the distal end portions 200, 250 relative to the respective support members 208, 256 may reduce or prevent twisting of leads. Leads and other features (e.g., guide-wire lumens and structural members, among others) within the support members 124, 208, 256 are omitted in FIGS. 2C-2E for simplicity of illustration.

[0036] FIGS. 3A-4B illustrate movement of radial-expansion members relative to corresponding support members in catheters configured in accordance with additional embodiments of the present technology. As one example, FIGS. 3A and 3B are side views of a radial-expansion member 300 and an associated segment of the support member 124 with

the radial-expansion member 300 shown in a radially extended state in FIG. 3A and in a radially constrained state in FIG. 3B. Unlike the radial-expansion members 126, the radial-expansion member 300 includes a proximal end portion 302 having a longitudinally slidable collar 304 and a distal end portion 306 having a fixed collar 308. As another example, FIGS. 4A and 4B are side views of a radial-expansion member 400 and an associated segment of a support member 402 with the radial-expansion member 400 shown in a radially extended state in FIG. 4A and in a radially constrained state in FIG. 4B. Unlike the radial-expansion members 126, 300, the radial-expansion member 400 includes a proximal end portion 404 having a longitudinally slidable collar 406 and a distal end portion 408 having a longitudinally slidable collar 410. The radial-expansion member 400 can further include a proximal stop 412 and a distal stop 414 fixedly connected to the support member 402 proximal and distal, respectively, to the radial-expansion member 400. The proximal stop 412 can be positioned to restrict proximal movement of the proximal end portion 404. Similarly, the distal stop 414 can be positioned to restrict distal movement of the distal end portion 408. Other arrangements of stops (not shown) can be envisioned in radial-expansion member 400, such as one long stop or two short stops positioned between collars 410, 412 to limit the range of positions that radial-expansion member 400 may take along support member 402 while still permitting the radially extended state shown in FIG. 4A to be fully attained.

[0037] With reference to again FIGS. 1A-1C, in the illustrated embodiment, the individual radial-expansion members 126 are circumferentially offset and longitudinally staggered relative to one another. This arrangement can be such that the therapeutic element 116 has an asymmetrical cross section in each transverse plane intersecting a given bridging portion 140. The incremental circumferential offset, i.e. the angular offset about support member 124, from a given radial-expansion member 126 to a proximally successive radial-expansion member 126 can be 90 degrees. For example, looking proximally from a distal end of the support member 124, the first radial-expansion member 128 can be oriented at 12 o'clock (0 degrees), the second radial-expansion member 130 can be oriented at 3 o'clock (90 degrees), the third radial-expansion member 132 can be oriented at 6 o'clock (180 degrees), and the fourth radial-expansion member 134 can be oriented at 9 o'clock (270 degrees). In other embodiments, the circumferential offset can be greater than 90 degrees (e.g., within a

range from 90 degrees to 180 degrees) or less than 90 degrees (e.g., within a range from 5 degrees to 90 degrees).

[0038] In some embodiments, the individual radial-expansion members 126 are planar with the distal and proximal end portions 136, 138 of a given radial-expansion member 126 having the same radial orientation relative to the support member 124. In other embodiments, the individual radial-expansion members 126 can be non-planar and the distal and proximal end portions 136, 138 of a given radial-expansion member 126 can have different radial orientations relative to the support member 124. FIGS. 5 and 6, for example, illustrate examples of non-planar radial-expansion members of therapeutic elements of catheters configured in accordance with additional embodiments of the present technology. FIG. 5 is a perspective view of a therapeutic element 500 including a plurality of non-planar radial-expansion members 502 that are twisted such that distal and proximal end portions 504, 506 of a given radial-expansion member 502 are circumferentially offset from one another. This can be useful, for example, to enhance alignment of the electrodes 146 with a desirable treatment profile, such as a helical treatment profile.

[0039] Similar to the therapeutic element 116 shown in FIG. 1A, in the embodiment shown in FIG. 5, the radial-expansion members 502 are circumferentially fully offset from one another. In contrast, FIG. 6 is a perspective view of a therapeutic element 600 including non-planar radial-expansion members 602 that are circumferentially interwoven. The radial-expansion members 602 can extend away from the support member 124 along one side of distally neighboring radial-expansion member 602 and twist back toward the support member along an opposite side of a proximally neighboring radial-expansion member 602. In other words, the distal end portion 604 of a given radial-expansion member 602 can be circumferentially offset to one side of a proximal end portion 606 of a distally neighboring radial-expansion member 602 while the proximal end portion 606 of the given radial-expansion member 602 is circumferentially offset to the opposite side of a distal end portion 604 of a proximally neighboring radial-expansion member 602. This can be useful, to further enhance alignment of the electrodes 146 with a desirable treatment profile, such as a helical treatment profile. For example, circumferentially interweaving the radial-expansion members 602 may reduce or prevent interference between neighboring radial-expansion member 602 during expansion and contraction even when the radial-expansion members 602 are sharply

twisted. In other embodiments, radial-expansion members can have other suitable configurations.

[0040] FIGS. 7A–7D are enlarged anatomical side views of the therapeutic element 116 shown in FIG. 1A and associated components being used for renal neuromodulation at a treatment site within a renal artery 700 that extends between an aorta 702 and a kidney 704 in a human patient. The therapeutic element 116 can also be used for other purposes and at treatment locations within other suitable body lumens. To locate the therapeutic element 116 at the treatment location, the catheter 102 can be advanced toward the treatment location while the therapeutic element 116 is radially constrained in a low-profile delivery state within a delivery sheath 706. In FIG. 7A, the therapeutic element 116 is in the delivery state hidden within the sheath 706. It will be understood by persons familiar with the field of catheterization that catheter 102 and sheath 706 would typically be guided, simultaneously or separately, from a vascular puncture site to renal artery 700 using a guiding catheter and/or a medical guidewire, both of which are omitted from FIGS. 7A-7D for simplicity of illustration.

[0041] In FIG. 7B, the therapeutic element 116 is shown in a first intermediate state as it transitions from the delivery state to a deployed state. Sheath 706 is shown as having been withdrawn from renal artery 700 sufficiently to expose only a distal portion of first radial expansion member 128, which remains radially constrained by delivery sheath 706. In FIG. 7C, the therapeutic element 116 is shown in a second intermediate state as it transitions from the first intermediate state to the deployed state. Sheath 706 is shown as having been withdrawn from renal artery 700 sufficiently to expose all of first radial expansion member 128, which has self-expanded into apposition with inner surface 708 of a wall 710 of the renal artery 700. As shown in FIGS. 7B and 7C, deploying the therapeutic element 116 can include independently expanding the radial-expansion members 128, 130, 132, 134 one at a time in a distal-to-proximal sequence. This can include retracting the sheath 706 relative to the catheter 102 (FIG. 1A) and/or advancing the catheter 102 relative to the sheath 706 so as to allow the unconstrained radial-expansion members 126 to resiliently urge the electrodes 146 toward an inner surface 708 of a wall 710 of the renal artery 700. In FIG. 7D, the therapeutic element 116 is shown in the deployed state. Sheath 706 is shown as having been withdrawn from renal artery 700 sufficiently to expose all radial expansion members 128, 130, 132, 134, which have self-expanded into apposition with inner surface 708 of a wall 710 of the renal

artery 700. In the embodiment shown, radial expansion members 128, 130, 132, 134 are configured such that electrodes 146 form a series of longitudinally and circumferentially spaced-apart contact regions 712 disposed along a helical path. After therapeutic element 116 is deployed at the treatment location, electrodes 146 can be energized to modulate one or more nerves at or near the treatment location.

[0042] As discussed above, catheters configured in accordance with at least some embodiments of the present technology are expected to treat tissue (e.g., nerves) at or near treatment locations within geometrically irregular (e.g., non-cylindrical) segments of body lumens in a reliable and consistent manner. For example, FIG. 8 is an enlarged anatomical side view of the therapeutic element 116 in the deployed state and located at a treatment location within a lumen segment 800 including an obstruction 802. As shown in FIG. 8, the obstruction 802 is expected to partially inhibit full radial expansion of some, but not all, of the radial-expansion members 126, such as the third radial-expansion member 132 only. This, however, is expected to have little or no effect on radial expansion of the other radial-expansion members 126 or on the ability of the therapeutic element 116 to achieve stable contact between the electrodes 146 and an inner surface 804 of a wall 806 of the lumen segment 800.

[0043] As another example, FIG. 9 is an enlarged anatomical side view of the therapeutic element 116 in the deployed state and located at a treatment location within a curved lumen segment 900. As shown in FIG. 9, the curve is expected to urge the support member 124 away from the center of the lumen segment 900 and thereby partially inhibit full radial expansion of some, but not all, of the radial-expansion members 126, such as the second and third radial-expansion members 130, 132 only. This, however, is expected to have little or no effect on the radial expansion of the other radial-expansion members 126 or on the ability of the therapeutic element 116 to achieve stable contact between the electrodes 146 and an inner surface 902 of a wall 904 of the lumen segment 900. The behavior illustrated in FIGS. 8 and 9 is by way of theory only and is not intended to limit the scope of the present technology. The therapeutic element 116 may behave differently in practice and may have the same or different advantages. Furthermore, the therapeutic element 116 may have advantages entirely distinct from the advantages described with reference to FIGS. 8 and 9.

[0044] As discussed above with reference to FIGS. 7A-7D, in some embodiments, radial-expansion members are configured to expand one at a time in a distal-to-proximal sequence. In other embodiments, radial-expansion members can be configured to expand in another suitable manner, such as simultaneously. FIGS. 10A-10B illustrate three radial-expansion members 1000 (individually identified as radial-expansion members 1000a-c) configured to be exposed from within a sheath (not shown) and then expanded (e.g., simultaneously expanded) by retraction of a control member 1002. The radial-expansion members 1000 can be operably connected to a support element 1003 including a tube 1004 defining a lumen 1006. For clarity of illustration, only distal portions of the respective radial-expansion members 1000 are shown in FIGS. 10A-10B. At their respective distal portions, the radial-expansion members 1000 can include a neck 1008. The tube 1004 can include a series of slots 1010 through which the individual necks 1008 respectively extend. The individual radial-expansion members 1000 can further include a nub 1012 connected to a distal end of the neck 1008. Proximal end portions (not shown) of the radial-expansion members 1000 can be fixedly connected to the tube 1004. The individual radial-expansion members 1000 can have different circumferential positions about a longitudinal axis of the support element 1003. In FIGS. 10A-10B, however, the individual radial-expansion members 1000 are shown in the same plane for clarity of illustration.

[0045] The control member 1002 can be slidably received within the lumen 1006. In the illustrated embodiment, the control member 1002 includes a series of stepped-down segments 1014 (individually identified as stepped-down segments 1014a-d) arranged from proximal to distal with successively decreasing diameters. The control member 1002 can further include shoulders or beveled ledges 1016 individually positioned between longitudinally neighboring pairs of the stepped-down segments 1014. A guide-wire lumen (not shown) can extend longitudinally through a central region of the control member 1002, such as in alignment with the distalmost stepped-down segment 1014d. In at least some other embodiments, the control member 1002 has a more consistent diameter, such as a diameter equal to the diameter of the distalmost stepped-down segment 1014d. In these embodiments, for example, the control member 1002 can include longitudinally spaced apart rings or other circumferential enlargements (not shown) arranged from proximal to distal with successively increasing diameters. This can be useful, for example, to increase the flexibility of the control member 1002.

[0046] In FIGS. 10A and 10B, the radial-expansion members 1000 are shown in radially constrained states and radially expanded states, respectively. During delivery to a treatment location, the control member 1002 can hold the radial-expansion members 1000 in the radially constrained states. For example, the control member 1002 can be at a distally advanced position with the beveled ledges 1016 respectively pressing against the nubs 1012 to hold the radial-expansion members 1000 in the radially constrained states. The radial-expansion members 1000 can be resiliently biased toward the radially expanded states. To expand the radial-expansion members 1000, the control member 1002 can be retracted proximally to release constraint on the radial-expansion members 1000 and thereby allow the radial-expansion members 1000 to assume the radially constrained states.

[0047] The distal necks 1008, the nubs 1012, or both, can be configured to interact with (e.g., to catch) different respective beveled ledges 1016. This can facilitate independent expansion of the radial-expansion members 1000. For example, the distal necks 1008 can have successively increasing lengths from proximal to distal so as to align the nubs 1012 with respective beveled ledges 1016. Alternatively or in addition, the nubs 1012 can have successively increasing sizes from proximal to distal so as to catch different respective beveled ledges 1016. As the control member 1002 is retracted proximally, any stepped-down segments 1014 distal to a given beveled ledge 1016 aligned with a given nub 1012 can pass by the given nub 1012 without restricting the corresponding radial-expansion member 1000 from moving into its radially constrained state, such as due to the presence of an obstruction or a curve in a lumen segment within which the radial-expansion member 1000 is positioned. This can facilitate the independent operation of the radial-expansion member 1000.

Renal Neuromodulation

[0048] Catheters configured in accordance with at least some embodiments of the present technology can be well suited (e.g., with respect to sizing, flexibility, operational characteristics, and/or other attributes) for performing renal neuromodulation in human patients. Renal neuromodulation is the partial or complete incapacitation or other effective disruption of nerves of the kidneys (e.g., nerves terminating in the kidneys or in structures closely associated with the kidneys). In particular, renal neuromodulation can include inhibiting, reducing, and/or blocking neural communication along neural fibers (e.g., efferent and/or afferent neural fibers) of the kidneys. Such incapacitation can be long-term (e.g., permanent or for periods of months, years, or decades) or short-term (e.g., for periods of

minutes, hours, days, or weeks). Renal neuromodulation is expected to contribute to the systemic reduction of sympathetic tone or drive and/or to benefit at least some specific organs and/or other bodily structures innervated by sympathetic nerves. Accordingly, renal neuromodulation is expected to be useful in treating clinical conditions associated with systemic sympathetic overactivity or hyperactivity, particularly conditions associated with central sympathetic overstimulation. For example, renal neuromodulation is expected to efficaciously treat hypertension, heart failure, acute myocardial infarction, metabolic syndrome, insulin resistance, diabetes, left ventricular hypertrophy, chronic and end stage renal disease, inappropriate fluid retention in heart failure, cardio-renal syndrome, polycystic kidney disease, polycystic ovary syndrome, osteoporosis, erectile dysfunction, and sudden death, among other conditions.

[0049] Renal neuromodulation can be electrically-induced, thermally-induced, chemically-induced, or induced in another suitable manner or combination of manners at one or more suitable treatment locations during a treatment procedure. The treatment location can be within or otherwise proximate to a renal lumen (e.g., a renal artery, a ureter, a renal pelvis, a major renal calyx, a minor renal calyx, or another suitable structure), and the treated tissue can include tissue at least proximate to a wall of the renal lumen. For example, with regard to a renal artery, a treatment procedure can include modulating nerves in the renal plexus, which lay intimately within or adjacent to the adventitia of the renal artery. Various suitable modifications can be made to the catheters described above to accommodate different treatment modalities. For example, the electrodes 146 (FIG. 1B) can be replaced with transducers to facilitate transducer-based treatment modalities. As another example, the electrodes 146 can be replaced with drug-delivery elements (e.g., needles) to facilitate chemical-based treatment modalities. Other suitable modifications are also possible.

[0050] Renal neuromodulation can include an electrode-based or treatment modality alone or in combination with another treatment modality. Electrode-based or transducer-based treatment can include delivering electricity and/or another form of energy to tissue at or near a treatment location to stimulate and/or heat the tissue in a manner that modulates neural function. For example, sufficiently stimulating and/or heating at least a portion of a sympathetic renal nerve can slow or potentially block conduction of neural signals to produce a prolonged or permanent reduction in renal sympathetic activity. A variety of suitable types of energy can be used to stimulate and/or heat tissue at or near a treatment location. For

example, neuromodulation in accordance with embodiments of the present technology can include delivering RF energy, pulsed electrical energy, microwave energy, optical energy, focused ultrasound energy (e.g., high-intensity focused ultrasound energy), and/or another suitable type of energy. An electrode or transducer used to deliver this energy can be used alone or with other electrodes or transducers in a multi-electrode or multi-transducer array.

[0051] Neuromodulation using focused ultrasound energy (e.g., high-intensity focused ultrasound energy) can be beneficial relative to neuromodulation using other treatment modalities. Focused ultrasound is an example of a transducer-based treatment modality that can be delivered from outside the body. Focused ultrasound treatment can be performed in close association with imaging (e.g., magnetic resonance, computed tomography, fluoroscopy, ultrasound (e.g., intravascular or intraluminal), optical coherence tomography, or another suitable imaging modality). For example, imaging can be used to identify an anatomical position of a treatment location (e.g., as a set of coordinates relative to a reference point). The coordinates can then entered into a focused ultrasound device configured to change the power, angle, phase, or other suitable parameters to generate an ultrasound focal zone at the location corresponding to the coordinates. The focal zone can be small enough to localize therapeutically-effective heating at the treatment location while partially or fully avoiding potentially harmful disruption of nearby structures. To generate the focal zone, the ultrasound device can be configured to pass ultrasound energy through a lens, and/or the ultrasound energy can be generated by a curved transducer or by multiple transducers in a phased array, which can be curved or straight.

[0052] Heating effects of electrode-based or transducer-based treatment can include ablation and/or non-ablative alteration or damage (e.g., via sustained heating and/or resistive heating). For example, a treatment procedure can include raising the temperature of target neural fibers to a target temperature above a first threshold to achieve non-ablative alteration, or above a second, higher threshold to achieve ablation. The target temperature can be higher than about body temperature (e.g., about 37°C) but less than about 45°C for non-ablative alteration, and the target temperature can be higher than about 45°C for ablation. Heating tissue to a temperature between about body temperature and about 45°C can induce non-ablative alteration, for example, via moderate heating of target neural fibers or of luminal structures that perfuse the target neural fibers. In cases where luminal structures are affected, the target neural fibers can be denied perfusion resulting in necrosis of the neural tissue.

Heating tissue to a target temperature higher than about 45°C (e.g., higher than about 60°C) can induce ablation, for example, via substantial heating of target neural fibers or of luminal structures that perfuse the target fibers. In some patients, it can be desirable to heat tissue to temperatures that are sufficient to ablate the target neural fibers or the luminal structures, but that are less than about 90°C (e.g., less than about 85°C, less than about 80°C, or less than about 75°C).

[0053] Renal neuromodulation can include a chemical-based treatment modality alone or in combination with another treatment modality. Neuromodulation using chemical-based treatment can include delivering one or more chemicals (e.g., drugs or other agents) to tissue at or near a treatment location in a manner that modulates neural function. The chemical, for example, can be selected to affect the treatment location generally or to selectively affect some structures at the treatment location over other structures. The chemical, for example, can be guanethidine, ethanol, phenol, a neurotoxin, or another suitable agent selected to alter, damage, or disrupt nerves. A variety of suitable techniques can be used to deliver chemicals to tissue at or near a treatment location. For example, chemicals can be delivered via one or more needles originating outside the body or within the vasculature or other body lumens. In an intravascular example, a catheter can be used to intravascularly position a therapeutic element including a plurality of needles (e.g., micro-needles) that can be retracted or otherwise blocked prior to deployment. In other embodiments, a chemical can be introduced into tissue at or near a treatment location via simple diffusion through a body lumen wall, electrophoresis, or another suitable mechanism. Similar techniques can be used to introduce chemicals that are not configured to cause neuromodulation, but rather to facilitate neuromodulation via another treatment modality.

Examples

1. A neuromodulation catheter, comprising:
an elongate shaft; and
a neuromodulation element operably connected to the shaft, the neuromodulation element including—
an elongate support member, and
a plurality of bow springs operably connected to the support member, the individual bow springs including a distal leg and a proximal leg, the

distal and proximal legs of the plurality of bow springs being longitudinally interdigitated.

2. The neuromodulation catheter of example 1 wherein the distal and proximal legs of the individual bow springs have the same radial orientation relative to the support member.

3. The neuromodulation catheter of example 1 wherein the distal and proximal legs of the individual bow springs have different radial orientations relative to the support member.

4. The neuromodulation catheter of any one of examples 1-3, wherein the plurality of bow springs is circumferentially interwoven.

5. The neuromodulation catheter of any one of examples 1-4, wherein the individual bow springs are configured to independently expand radially outward from the support member when the neuromodulation element transitions from a low-profile delivery state to a deployed state.

6. The neuromodulation catheter of any one of examples 1-5, wherein the individual bow springs are self-expanding.

7. The neuromodulation catheter of any one of examples 1-6, wherein:
the shaft is configured to locate the neuromodulation element at a treatment location within a body lumen having a lumen wall;
the individual bow springs carry or otherwise include an electrode and/or a transducer between their respective distal and proximal legs; and
the plurality of bow springs is configured to urge the electrodes and/or the transducers into contact with an inner surface of the lumen wall at a series of longitudinally and circumferentially spaced-apart contact regions when the neuromodulation element is in the deployed state at the treatment location.

8. The neuromodulation catheter of any one of examples 1-7, wherein the contact regions are disposed along a helical path.

9. The neuromodulation catheter of any one of examples 1-8, wherein:
the plurality of bow springs includes a first bow spring, a second bow spring, and a third bow spring, respectively positioned in a distal-to-proximal sequence;
the distal leg of the second bow spring is longitudinally slidable along a segment of the support member between the distal and proximal legs of the first bow spring; and
the distal leg of the third bow spring is longitudinally slidable along a segment of the support member between the distal and proximal legs of the second bow spring.
10. The neuromodulation catheter of example 9 wherein:
the proximal leg of the first bow spring is longitudinally slidable along a segment of the support member between the distal and proximal legs of the second bow spring; and
the proximal leg of the second bow spring is longitudinally slidable along a segment of the support member between the distal and proximal legs of the third bow spring.
11. The neuromodulation catheter of example 9, wherein:
the proximal leg of the first bow spring is fixedly connected to the support member between the distal and proximal legs of the second bow spring; and
the proximal leg of the second bow spring is fixedly connected to the support member between the distal and proximal legs of the third bow spring.
12. The neuromodulation catheter of any one of examples 9-11, wherein the distal legs of the second and third bow springs individually include a fully or partially circumferential collar configured to slide along an exterior surface of the respective segment of the support member.
13. The neuromodulation catheter of example 12 wherein the collars and the corresponding exterior surfaces of the support member are keyed to restrict rotation of the collars relative to the support member.

14. The neuromodulation catheter of any one of examples 9-11, wherein the distal legs of the second and third bow springs individually include an enlarged head slidably disposed within a single channel or, respectively, within different channels defined by the support member.

15. A neuromodulation catheter comprising:

an elongate shaft; and

a neuromodulation element operably connected to the shaft, the neuromodulation element including—

an elongate support member,

a first radial-expansion member having—

a first distal end portion operably connected to the support member at a first position along a length of the support member,

a first proximal end portion operably connected to the support member at a second position along the length of the support member,

and

a first bridging portion extending between the first distal end portion and the first proximal end portion, the first bridging portion carrying or otherwise including a first electrode or transducer,

wherein the first bridging portion is configured to expand radially outward from the support member in conjunction with the first distal end portion moving proximally toward the first proximal end portion and/or the first proximal end portion moving distally toward the first distal end portion, and

a second radial-expansion member having—

a second distal end portion operably connected to the support member at a third position along the length of the support member, the third position being between the first and second positions

a second proximal end portion operably connected to the support member at a fourth position along the length of the support member, the fourth position being proximal to the second position, and

a second bridging portion extending between the second distal end portion and the second proximal end portion, the second bridging portion carrying or otherwise including a second electrode or transducer,

wherein the second bridging portion is configured to expand radially outward from the support member in conjunction with the second distal end portion moving proximally toward the second proximal end portion and/or the second proximal end portion moving distally toward the second distal end portion.

16. The neuromodulation catheter of example 15 wherein the first and second radial-expansion members are resiliently biased to expand the first and second bridging portions, respectively, radially outward from the support member.

17. The neuromodulation catheter of example 15 or example 16, wherein the neuromodulation element has an asymmetrical cross section in all transverse planes intersecting the second bridging portion.

18. The neuromodulation catheter of any of examples 15-17, wherein the second radial-expansion member is slidably connected to the support member via the second distal end portion and fixedly connected to the support member via the second proximal end portion.

19. The neuromodulation catheter of any of examples 15-17, wherein the second radial-expansion member is slidably connected to the support member via the second proximal end portion and fixedly connected to the support member via the second distal end portion.

20. The neuromodulation catheter of any of examples 15-17, wherein the second radial-expansion member is slidably connected to the support member via the second proximal end portion and via the second distal end portion.

21. The neuromodulation catheter of any of examples 15-20, wherein the support member includes one or more stops positioned to restrict longitudinal movement of the second proximal end portion and/or the second distal end portion.

22. A neuromodulation method, comprising:
advancing an elongate shaft of a neuromodulation catheter toward a treatment location within a body lumen of a human patient while a neuromodulation element of the catheter is in a low-profile delivery state;
independently expanding a series of bow springs of the neuromodulation element one at a time in a distal-to-proximal sequence as the neuromodulation element transitions from the delivery state to a deployed state at the treatment location;
and
energizing electrodes and/or transducers carried by the bow springs to modulate one or more nerves of the patient while the neuromodulation element is at the treatment location and in the deployed state.

23. The neuromodulation method of example 22 wherein:
advancing the shaft includes advancing the shaft while the neuromodulation element is disposed within a sheath; and
independently expanding the bow springs includes retracting the sheath relative to the neuromodulation catheter and/or advancing the neuromodulation catheter relative to the sheath so as to allow the bow springs to resiliently urge the electrodes and/or the transducers toward an inner surface of a wall of the body lumen.

24. The neuromodulation method of example 22 or example 23, wherein independently expanding the bow springs includes urging the electrodes and/or the transducers into contact with an inner surface of a wall of the body lumen at a series of longitudinally and circumferentially spaced-apart contact regions.

25. The neuromodulation method of any of examples 22-24, wherein the contact regions are disposed along a helical path.

Conclusion

[0054] This disclosure is not intended to be exhaustive or to limit the present technology to the precise forms disclosed herein. Although specific embodiments are disclosed herein for illustrative purposes, various equivalent modifications are possible without deviating from the present technology, as those of ordinary skill in the relevant art will recognize. In some cases, well-known structures and functions have not been shown and/or described in detail to avoid unnecessarily obscuring the description of the embodiments of the present technology. Although steps of methods may be presented herein in a particular order, in alternative embodiments the steps may have another suitable order. Similarly, certain aspects of the present technology disclosed in the context of particular embodiments can be combined or eliminated in other embodiments. Furthermore, while advantages associated with certain embodiments may have been disclosed in the context of those embodiments, other embodiments may also exhibit such advantages, and not all embodiments need necessarily exhibit such advantages or other advantages disclosed herein to fall within the scope of the present technology. Accordingly, this disclosure and associated technology can encompass other embodiments not expressly shown and/or described herein.

[0055] Certain aspects of the present technology may take the form of computer-executable instructions, including routines executed by a controller or other data processor. In some embodiments, a controller or other data processor is specifically programmed, configured, and/or constructed to perform one or more of these computer-executable instructions. Furthermore, some aspects of the present technology may take the form of data (e.g., non-transitory data) stored or distributed on computer-readable media, including magnetic or optically readable and/or removable computer discs as well as media distributed electronically over networks. Accordingly, data structures and transmissions of data particular to aspects of the present technology are encompassed within the scope of the present technology. The present technology also encompasses methods of both programming computer-readable media to perform particular steps and executing the steps.

[0056] The methods disclosed herein include and encompass, in addition to methods of practicing the present technology (e.g., methods of making and using the disclosed devices and systems), methods of instructing others to practice the present technology. For example, a method in accordance with a particular embodiment includes advancing an elongate shaft of a neuromodulation catheter toward a treatment location within a body lumen of a human patient while a neuromodulation element of the catheter is in a low-profile delivery state,

independently expanding a series of bow springs of the neuromodulation element one at a time in a distal-to-proximal sequence as the neuromodulation element transitions from the delivery state to a deployed state at the treatment location, and energizing electrodes and/or transducers carried by the bow springs to modulate one or more nerves of the patient while the neuromodulation element is at the treatment location and in the deployed state. A method in accordance with another embodiment includes instructing such a method.

[0057] Throughout this disclosure, the singular terms "a," "an," and "the" include plural referents unless the context clearly indicates otherwise. Similarly, unless the word "or" is expressly limited to mean only a single item exclusive from the other items in reference to a list of two or more items, then the use of "or" in such a list is to be interpreted as including (a) any single item in the list, (b) all of the items in the list, or (c) any combination of the items in the list. Additionally, the terms "comprising" and the like are used throughout this disclosure to mean including at least the recited feature(s) such that any greater number of the same feature(s) and/or one or more additional types of features are not precluded. Directional terms, such as "upper," "lower," "front," "back," "vertical," and "horizontal," may be used herein to express and clarify the relationship between various elements. It should be understood that such terms do not denote absolute orientation. Reference herein to "one embodiment," "an embodiment," or similar formulations means that a particular feature, structure, operation, or characteristic described in connection with the embodiment can be included in at least one embodiment of the present technology. Thus, the appearances of such phrases or formulations herein are not necessarily all referring to the same embodiment. Furthermore, various particular features, structures, operations, or characteristics may be combined in any suitable manner in one or more embodiments of the present technology.

CLAIMS

I/We claim:

1. A neuromodulation catheter, comprising:
an elongate shaft; and
a neuromodulation element operably connected to the shaft, the neuromodulation element including—
an elongate support member, and
a plurality of bow springs operably connected to the support member, the individual bow springs including a distal leg and a proximal leg, the distal and proximal legs of the plurality of bow springs being longitudinally interdigitated.
2. The neuromodulation catheter of claim 1 wherein the distal and proximal legs of the individual bow springs have the same radial orientation relative to the support member.
3. The neuromodulation catheter of claim 1 wherein the distal and proximal legs of the individual bow springs have different radial orientations relative to the support member.
4. The neuromodulation catheter of claim 3 wherein the plurality of bow springs is circumferentially interwoven.
5. The neuromodulation catheter of claim 1 wherein the individual bow springs are configured to independently expand radially outward from the support member when the neuromodulation element transitions from a low-profile delivery state to a deployed state.
6. The neuromodulation catheter of claim 5 wherein the individual bow springs are self-expanding.
7. The neuromodulation catheter of claim 5 wherein:
the shaft is configured to locate the neuromodulation element at a treatment location within a body lumen having a lumen wall;

the individual bow springs carry or otherwise include an electrode and/or a transducer between their respective distal and proximal legs; and
the plurality of bow springs is configured to urge the electrodes and/or the transducers into contact with an inner surface of the lumen wall at a series of longitudinally and circumferentially spaced-apart contact regions when the neuromodulation element is in the deployed state at the treatment location.

8. The neuromodulation catheter of claim 7 wherein the contact regions are disposed along a helical path.

9. The neuromodulation catheter of claim 1 wherein:
the plurality of bow springs includes a first bow spring, a second bow spring, and a third bow spring, respectively positioned in a distal-to-proximal sequence;
the distal leg of the second bow spring is longitudinally slidable along a segment of the support member between the distal and proximal legs of the first bow spring; and
the distal leg of the third bow spring is longitudinally slidable along a segment of the support member between the distal and proximal legs of the second bow spring.

10. The neuromodulation catheter of claim 9 wherein:
the proximal leg of the first bow spring is longitudinally slidable along a segment of the support member between the distal and proximal legs of the second bow spring; and
the proximal leg of the second bow spring is longitudinally slidable along a segment of the support member between the distal and proximal legs of the third bow spring.

11. The neuromodulation catheter of claim 9 wherein:
the proximal leg of the first bow spring is fixedly connected to the support member between the distal and proximal legs of the second bow spring; and
the proximal leg of the second bow spring is fixedly connected to the support member between the distal and proximal legs of the third bow spring.

12. The neuromodulation catheter of claim 9 wherein the distal legs of the second and third bow springs individually include a fully or partially circumferential collar configured to slide along an exterior surface of the respective segment of the support member.

13. The neuromodulation catheter of claim 12 wherein the collars and the corresponding exterior surfaces of the support member are keyed to restrict rotation of the collars relative to the support member.

14. The neuromodulation catheter of claim 9 wherein the distal legs of the second and third bow springs individually include an enlarged head slidably disposed within a single channel or, respectively, within different channels defined by the support member.

15. A neuromodulation catheter comprising:

an elongate shaft; and

a neuromodulation element operably connected to the shaft, the neuromodulation element including—

an elongate support member,

a first radial-expansion member having—

a first distal end portion operably connected to the support member at a first position along a length of the support member,

a first proximal end portion operably connected to the support member at a second position along the length of the support member, and

a first bridging portion extending between the first distal end portion and the first proximal end portion, the first bridging portion carrying or otherwise including a first electrode or transducer,

wherein the first bridging portion is configured to expand radially outward from the support member in conjunction with the first distal end portion moving proximally toward the first proximal end portion and/or the first proximal end portion moving distally toward the first distal end portion, and

a second radial-expansion member having—

a second distal end portion operably connected to the support member at a third position along the length of the support member, the third position being between the first and second positions

a second proximal end portion operably connected to the support member at a fourth position along the length of the support member, the fourth position being proximal to the second position, and

a second bridging portion extending between the second distal end portion and the second proximal end portion, the second bridging portion carrying or otherwise including a second electrode or transducer,

wherein the second bridging portion is configured to expand radially outward from the support member in conjunction with the second distal end portion moving proximally toward the second proximal end portion and/or the second proximal end portion moving distally toward the second distal end portion.

16. The neuromodulation catheter of claim 15 wherein the first and second radial-expansion members are resiliently biased to expand the first and second bridging portions, respectively, radially outward from the support member.

17. The neuromodulation catheter of claim 15 wherein the neuromodulation element has an asymmetrical cross section in all transverse planes intersecting the second bridging portion.

18. The neuromodulation catheter of claim 15 wherein the second radial-expansion member is slidably connected to the support member via the second distal end portion and fixedly connected to the support member via the second proximal end portion.

19. The neuromodulation catheter of claim 15 wherein the second radial-expansion member is slidably connected to the support member via the second proximal end portion and fixedly connected to the support member via the second distal end portion.

20. The neuromodulation catheter of claim 15 wherein the second radial-expansion member is slidably connected to the support member via the second proximal end portion and via the second distal end portion.

21. The neuromodulation catheter of claim 20 wherein the support member includes one or more stops positioned to restrict longitudinal movement of the second proximal end portion and/or the second distal end portion.

1/10

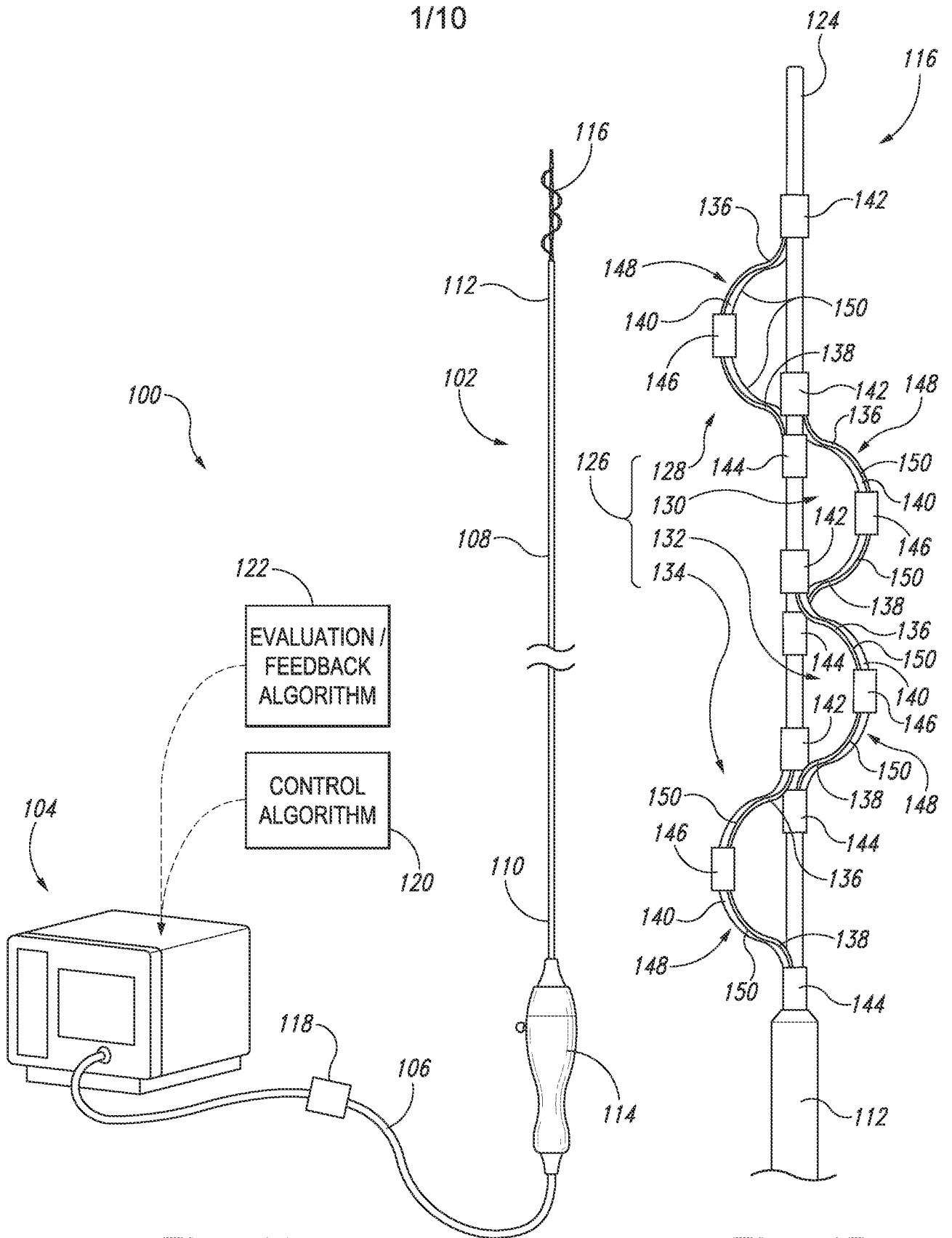

Fig. 1A

Fig. 1B

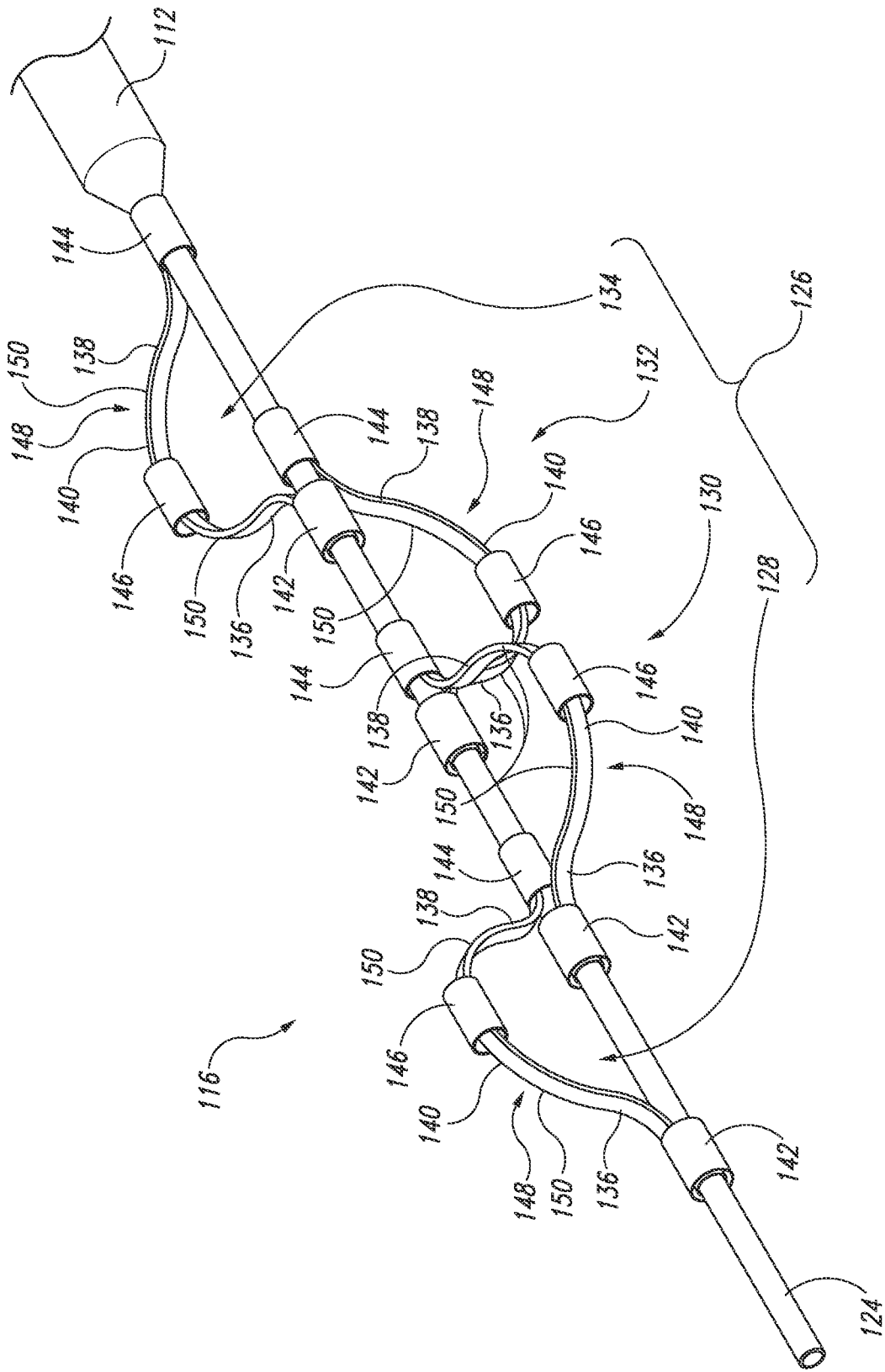

Fig. 1C

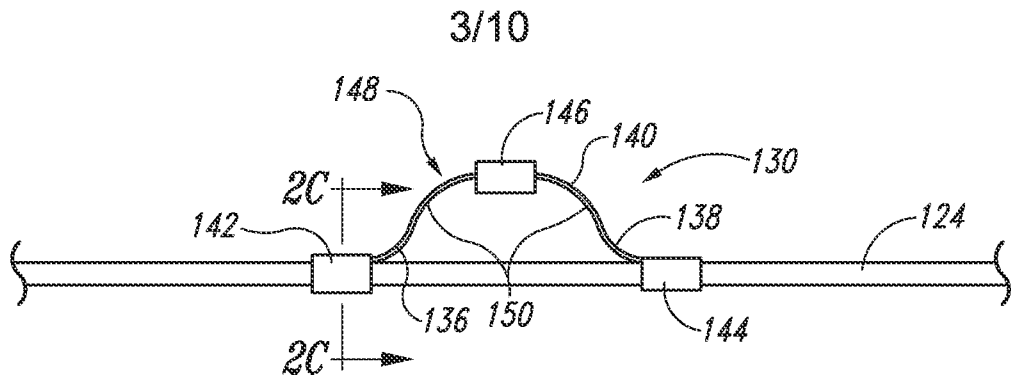

Fig. 2A

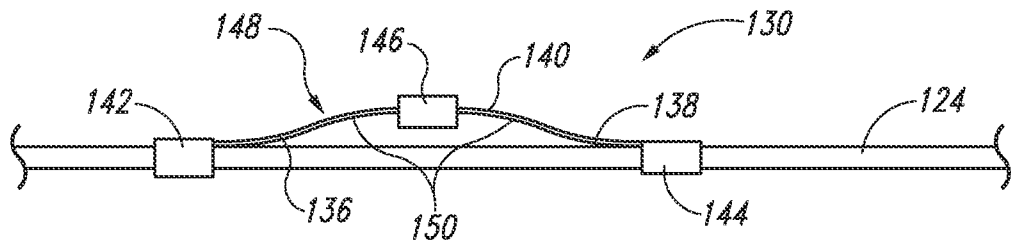

Fig. 2B

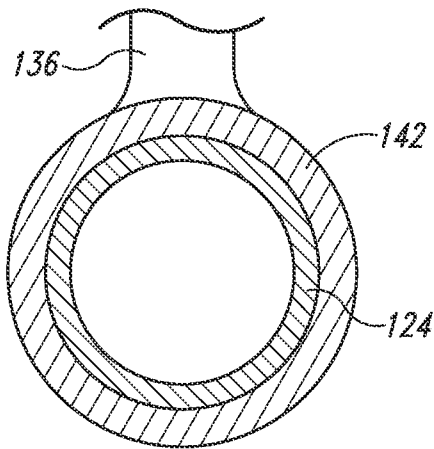

Fig. 2C

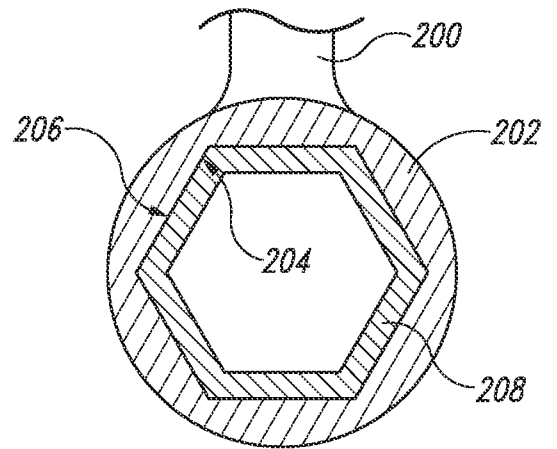

Fig. 2D

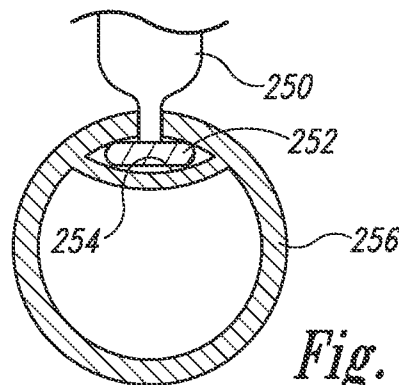

Fig. 2E

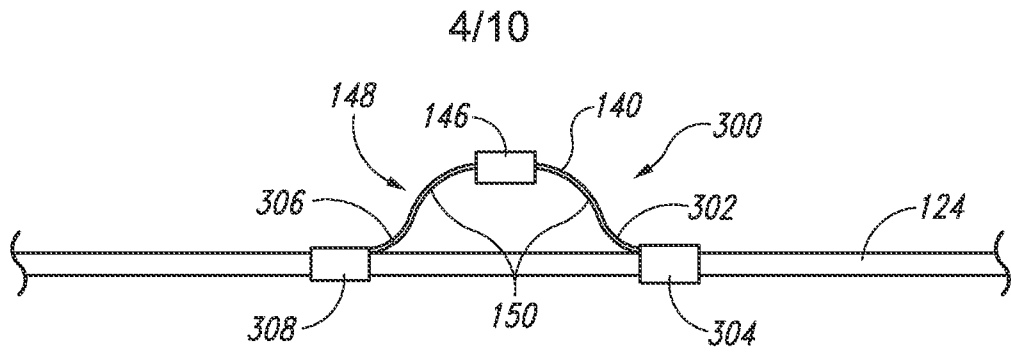

Fig. 3A

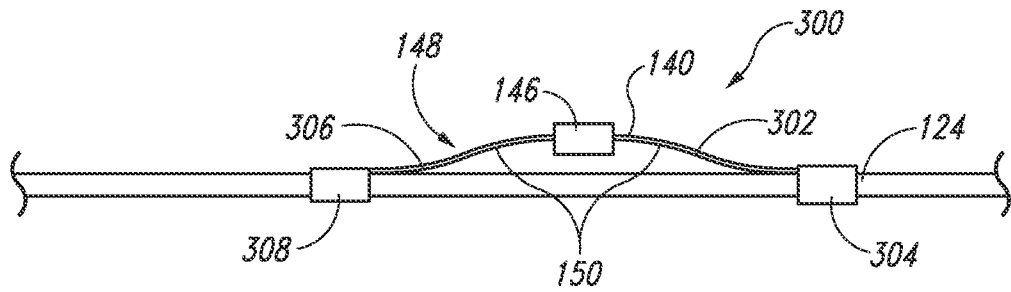

Fig. 3B

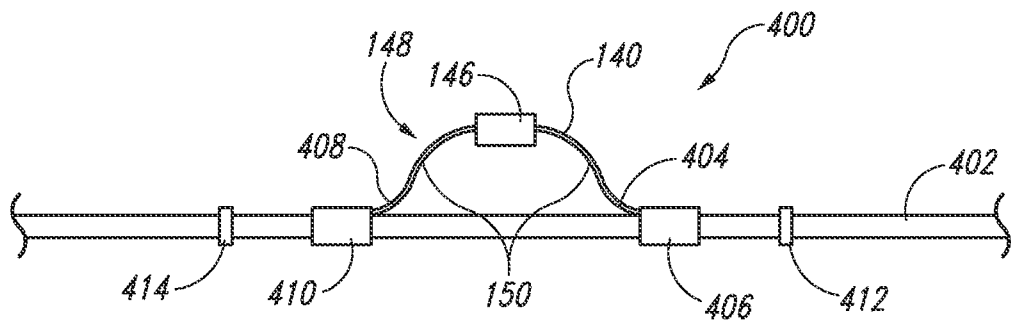

Fig. 4A

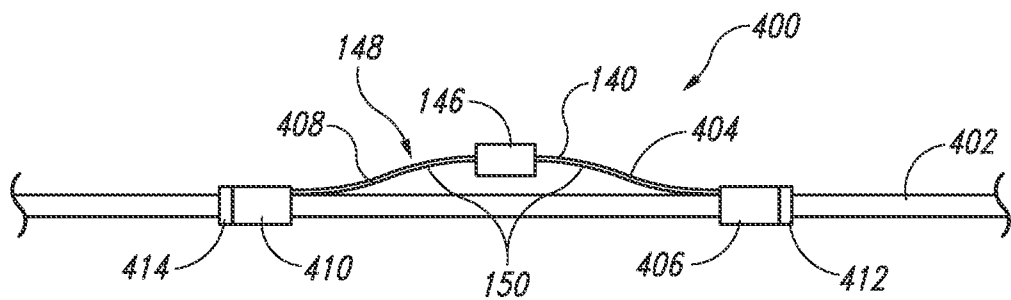

Fig. 4B

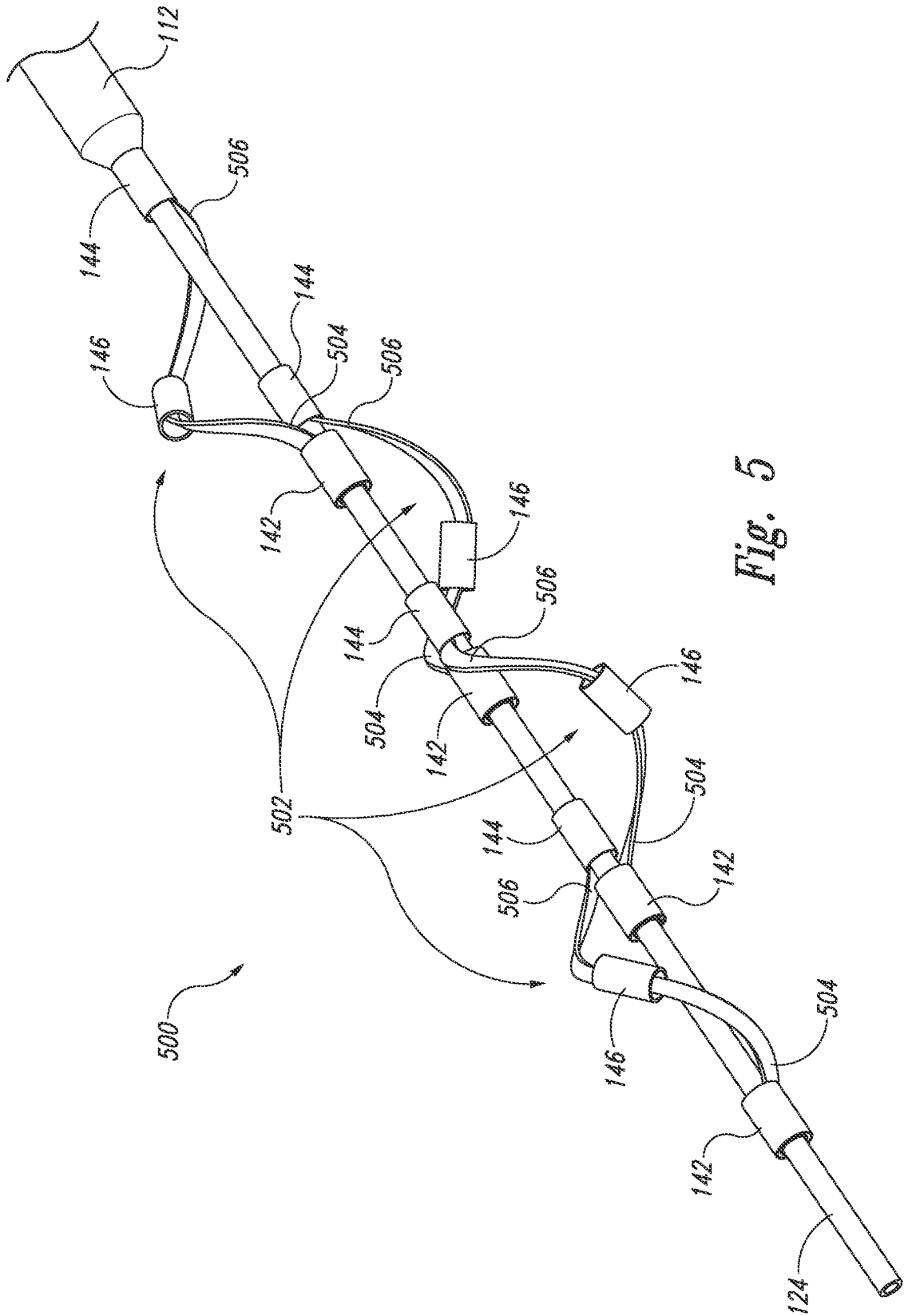

Fig. 5

6/10

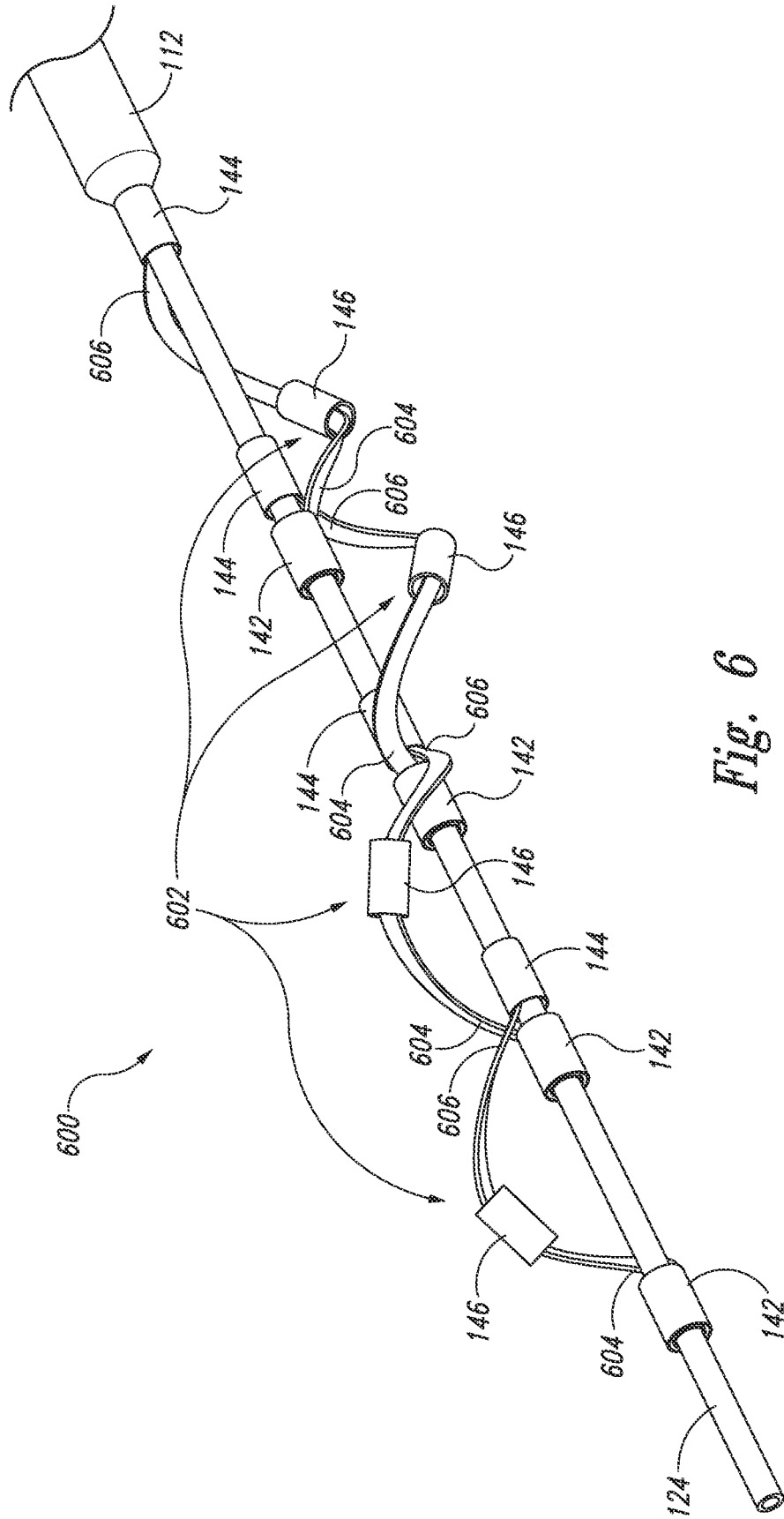

Fig. 6

7/10

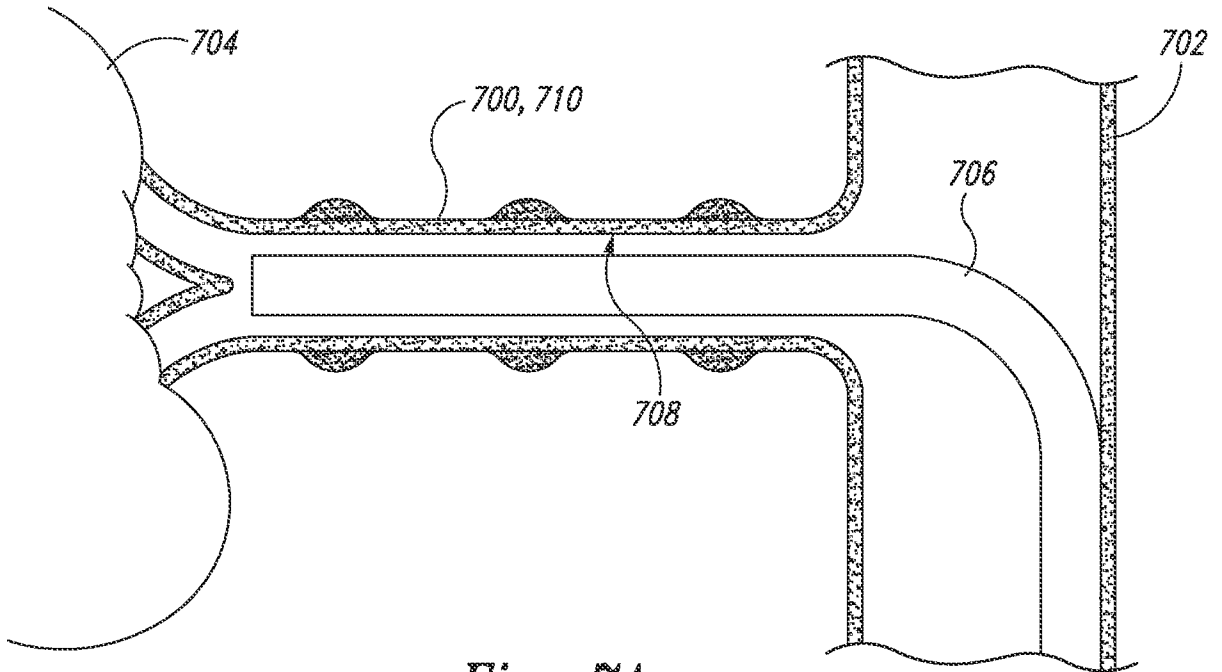

Fig. 7A

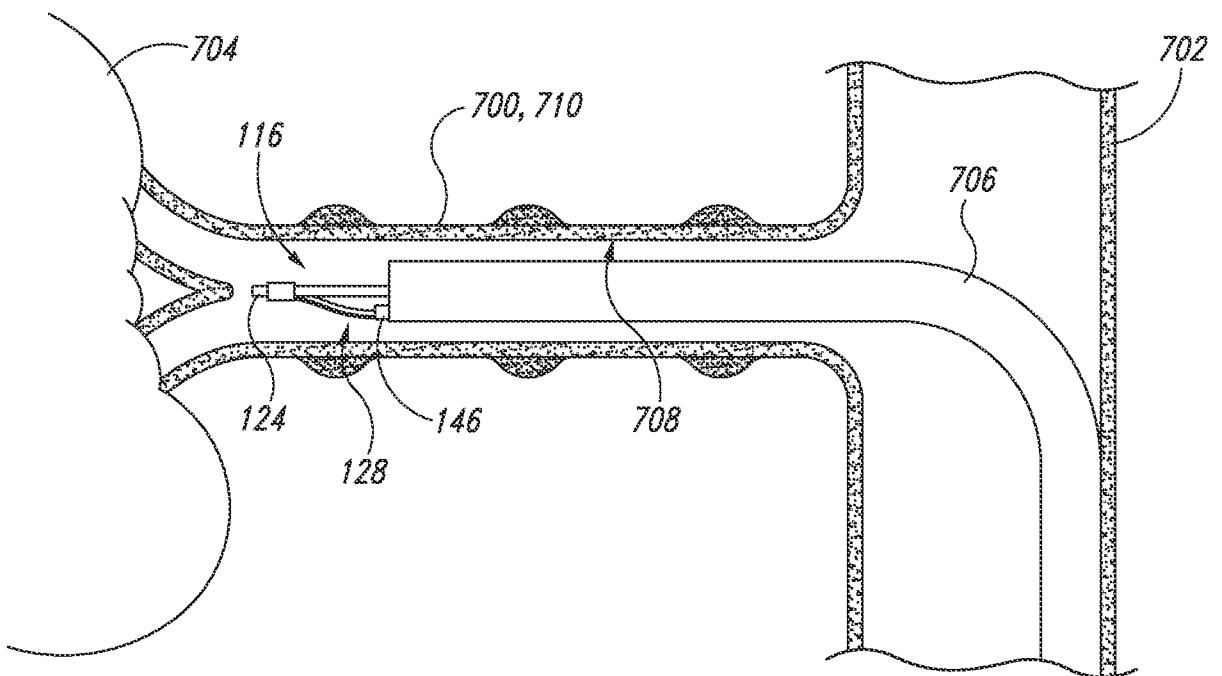

Fig. 7B

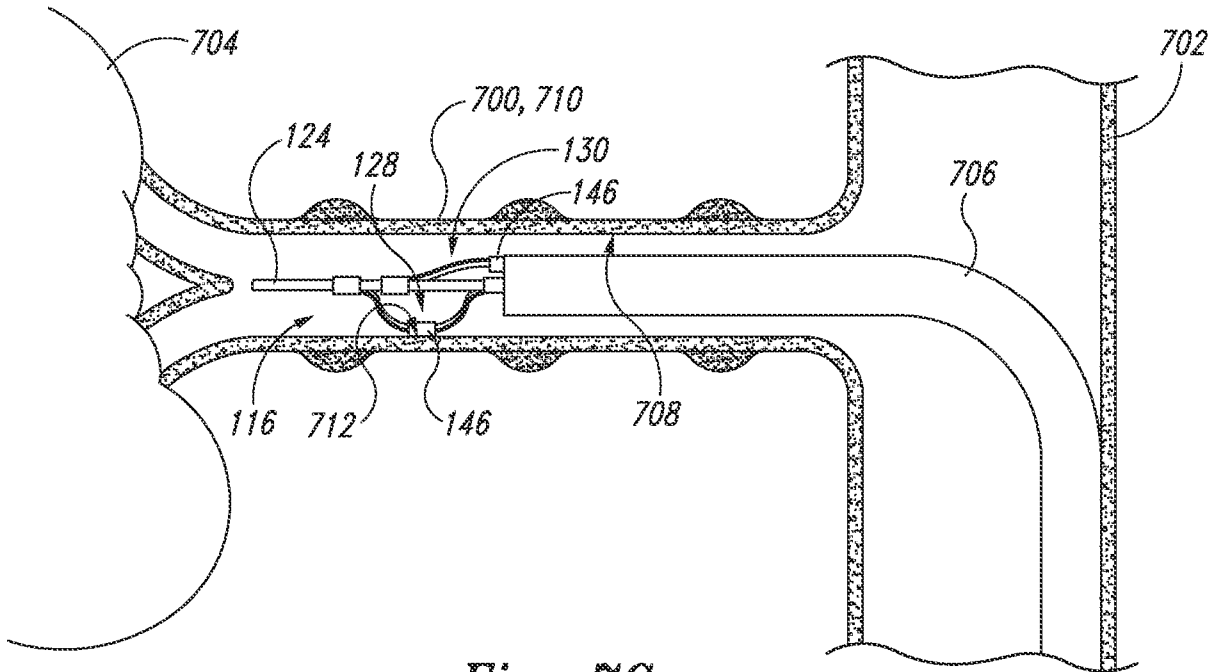

Fig. 7C

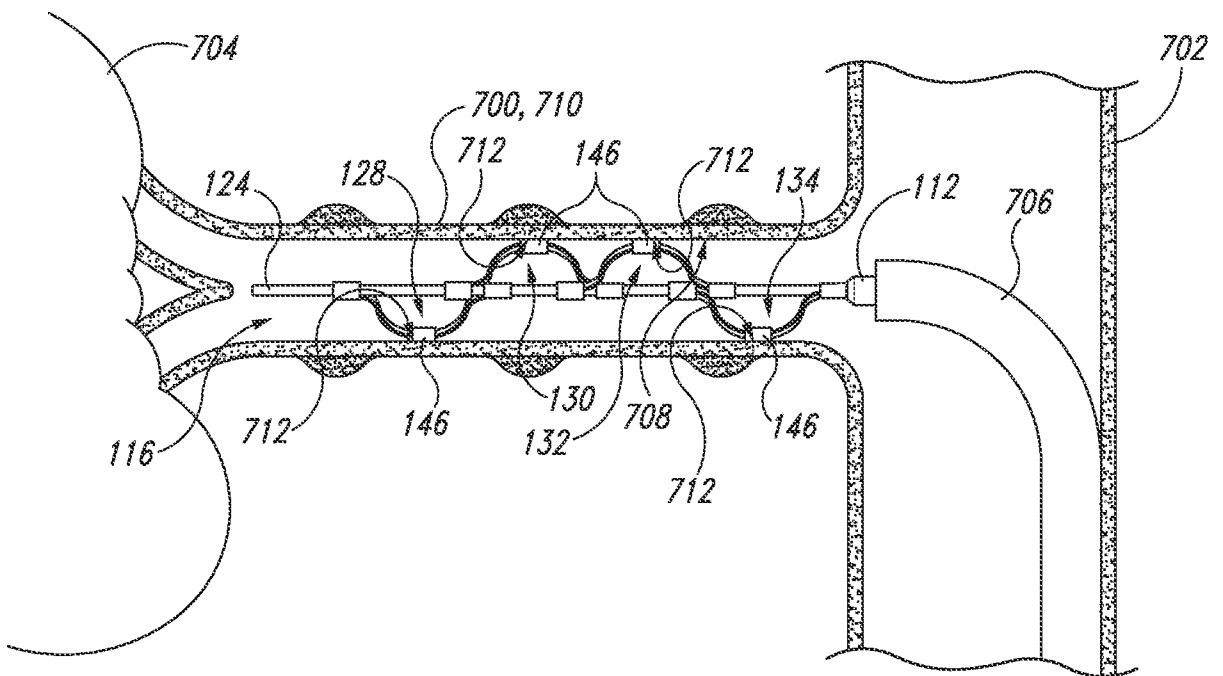

Fig. 7D

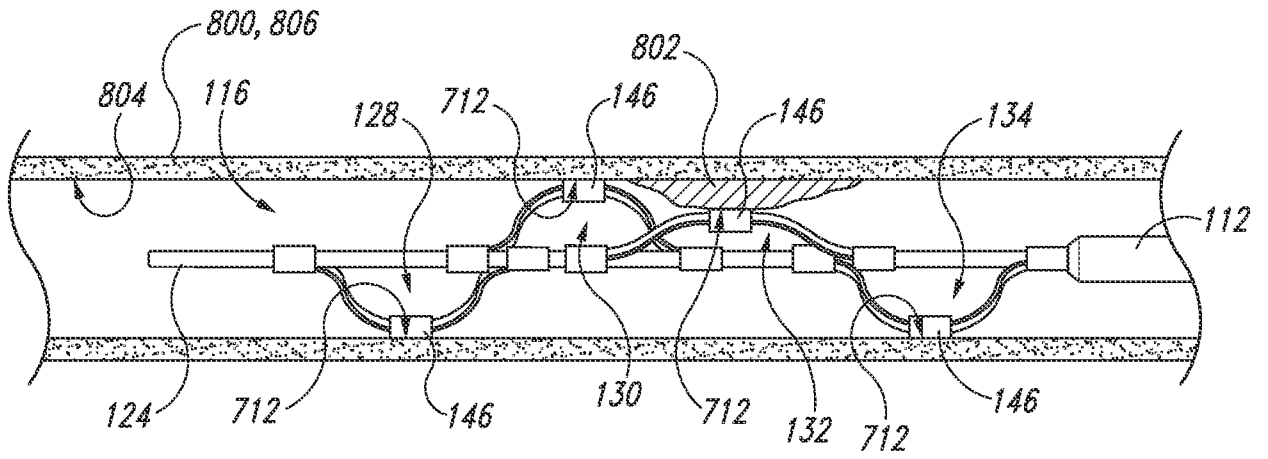

Fig. 8

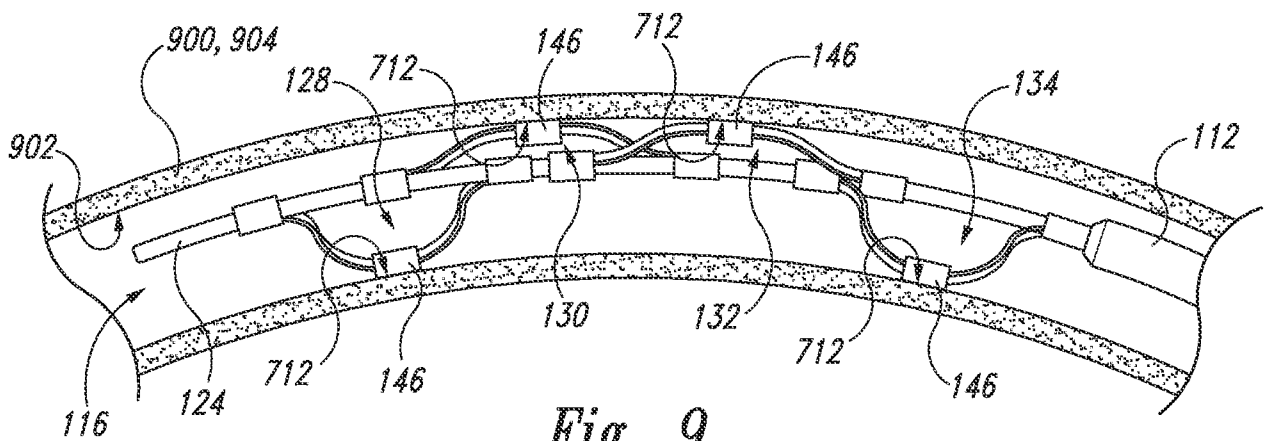

Fig. 9

INTERNATIONAL SEARCH REPORT

International application No
PCT/US2015/019986

A. CLASSIFICATION OF SUBJECT MATTER
INV. A61B18/14 A61B18/00
ADD.
According to International Patent Classification (IPC) or to both national classification and IPC

B. FIELDS SEARCHED
Minimum documentation searched (classification system followed by classification symbols)
A61B

Documentation searched other than minimum documentation to the extent that such documents are included in the fields searched

Electronic data base consulted during the international search (name of data base and, where practicable, search terms used)
EPO-Internal, WPI Data

C. DOCUMENTS CONSIDERED TO BE RELEVANT

Category*	Citation of document, with indication, where appropriate, of the relevant passages	Relevant to claim No.
X	US 2013/231659 A1 (HILL JASON P [US] ET AL) 5 September 2013 (2013-09-05)	1,2,5-21
A	abstract; figures 1, 11A, 11B paragraphs [0031] - [0082]	3,4
A	US 5 893 847 A (KORDIS THOMAS F [US]) 13 April 1999 (1999-04-13)	1-21
	abstract; figures 23,24,38,54 columns 5-19	

Further documents are listed in the continuation of Box C.

See patent family annex.

* Special categories of cited documents :

- "A" document defining the general state of the art which is not considered to be of particular relevance
- "E" earlier application or patent but published on or after the international filing date
- "L" document which may throw doubts on priority claim(s) or which is cited to establish the publication date of another citation or other special reason (as specified)
- "O" document referring to an oral disclosure, use, exhibition or other means
- "P" document published prior to the international filing date but later than the priority date claimed

- "T" later document published after the international filing date or priority date and not in conflict with the application but cited to understand the principle or theory underlying the invention
- "X" document of particular relevance; the claimed invention cannot be considered novel or cannot be considered to involve an inventive step when the document is taken alone
- "Y" document of particular relevance; the claimed invention cannot be considered to involve an inventive step when the document is combined with one or more other such documents, such combination being obvious to a person skilled in the art
- "&" document member of the same patent family

Date of the actual completion of the international search 2 June 2015	Date of mailing of the international search report 12/06/2015
---------------------------------------------------------------------------------	-------------------------------------------------------------------------

Name and mailing address of the ISA/ European Patent Office, P.B. 5818 Patentlaan 2 NL - 2280 HV Rijswijk Tel. (+31-70) 340-2040, Fax: (+31-70) 340-3016	Authorized officer Lins, Stephanie
----------------------------------------------------------------------------------------------------------------------------------------------------------------------	----------------------------------------------

INTERNATIONAL SEARCH REPORT

Information on patent family members

International application No

PCT/US2015/019986

Patent document cited in search report	Publication date	Patent family member(s)	Publication date	
US 2013231659	A1	05-09-2013	CN 104159536 A	19-11-2014
			EP 2819604 A1	07-01-2015
			US 2013231659 A1	05-09-2013
			WO 2013131046 A1	06-09-2013

US 5893847	A	13-04-1999	US 5893847 A	13-04-1999
			US 6216044 B1	10-04-2001
			US 2001029371 A1	11-10-2001
			US 2002198522 A1	26-12-2002
