

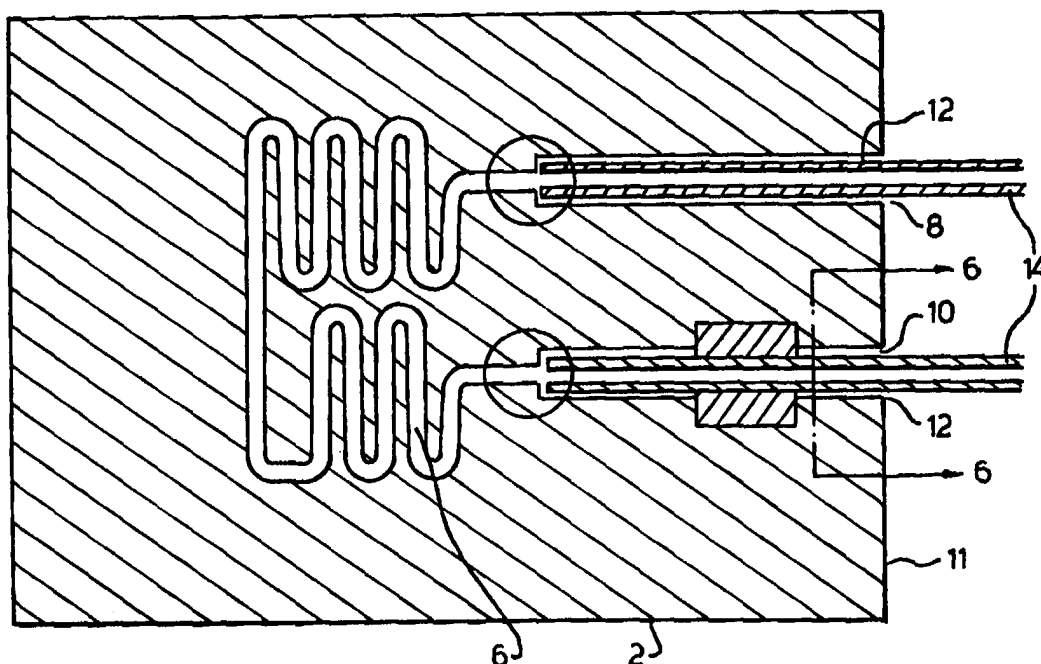

INTERNATIONAL APPLICATION PUBLISHED UNDER THE PATENT COOPERATION TREATY (PCT)

<p>(51) International Patent Classification ⁶ : F16L 13/11, F15C 5/00</p>	<p>A1</p>	<p>(11) International Publication Number: WO 98/25065 (43) International Publication Date: 11 June 1998 (11.06.98)</p>
<p>(21) International Application Number: PCT/GB97/03363 (22) International Filing Date: 4 December 1997 (04.12.97) (30) Priority Data: 9625491.7 7 December 1996 (07.12.96) GB (71) Applicant (for all designated States except US): CENTRAL RESEARCH LABORATORIES LIMITED [GB/GB]; Dawley Road, Hayes, Middlesex UB3 1HH (GB). (72) Inventors; and (75) Inventors/Applicants (for US only): CORLESS, Anthony, Robert [GB/GB]; Schillings, Pound Farm Lane, Ash GU12 6EG (GB). DODGSON, John, Robert [GB/GB]; 71 Ballards Way, Croydon, Surrey CR2 7JP (GB). SHAW, John, Edward, Andrew [GB/GB]; 45 Colne Avenue, West Drayton, Middlesex UB7 7AL (GB). TURNER, Chris [GB/GB]; 56 Waterside, Uxbridge, Middlesex UB8 2LQ (GB). (74) Agent: LEAMAN, Keith; QED Patents Limited, Dawley Road, Hayes, Middlesex UB3 1HH (GB).</p>		<p>(81) Designated States: AU, CA, CN, JP, KR, RU, SG, UA, US, European patent (AT, BE, CH, DE, DK, ES, FI, FR, GB, GR, IE, IT, LU, MC, NL, PT, SE). Published <i>With international search report. Before the expiration of the time limit for amending the claims and to be republished in the event of the receipt of amendments.</i></p>

(54) Title: FLUID CONNECTIONS



(57) Abstract

Apparatus comprising a micro engineered structure and a capillary or other small bore tube and a method for connecting the tube to the structure. The micro engineered structure is composed of at least one substrate (2) in which fluid flow channels (6) are formed, connecting to an aperture (12) into which the tube (14) is inserted. A sealant material is flowed into the aperture around the tube and then hardened in order to seal the tube within the aperture.

FOR THE PURPOSES OF INFORMATION ONLY

Codes used to identify States party to the PCT on the front pages of pamphlets publishing international applications under the PCT.

AL	Albania	ES	Spain	LS	Lesotho	SI	Slovenia
AM	Armenia	FI	Finland	LT	Lithuania	SK	Slovakia
AT	Austria	FR	France	LU	Luxembourg	SN	Senegal
AU	Australia	GA	Gabon	LV	Latvia	SZ	Swaziland
AZ	Azerbaijan	GB	United Kingdom	MC	Monaco	TD	Chad
BA	Bosnia and Herzegovina	GE	Georgia	MD	Republic of Moldova	TG	Togo
BB	Barbados	GH	Ghana	MG	Madagascar	TJ	Tajikistan
BE	Belgium	GN	Guinea	MK	The former Yugoslav Republic of Macedonia	TM	Turkmenistan
BF	Burkina Faso	GR	Greece			TR	Turkey
BG	Bulgaria	HU	Hungary	ML	Mali	TT	Trinidad and Tobago
BJ	Benin	IE	Ireland	MN	Mongolia	UA	Ukraine
BR	Brazil	IL	Israel	MR	Mauritania	UG	Uganda
BY	Belarus	IS	Iceland	MW	Malawi	US	United States of America
CA	Canada	IT	Italy	MX	Mexico	UZ	Uzbekistan
CF	Central African Republic	JP	Japan	NE	Niger	VN	Viet Nam
CG	Congo	KE	Kenya	NL	Netherlands	YU	Yugoslavia
CH	Switzerland	KG	Kyrgyzstan	NO	Norway	ZW	Zimbabwe
CI	Côte d'Ivoire	KP	Democratic People's Republic of Korea	NZ	New Zealand		
CM	Cameroon		Republic of Korea	PL	Poland		
CN	China	KR	Republic of Korea	PT	Portugal		
CU	Cuba	KZ	Kazakstan	RO	Romania		
CZ	Czech Republic	LC	Saint Lucia	RU	Russian Federation		
DE	Germany	LI	Liechtenstein	SD	Sudan		
DK	Denmark	LK	Sri Lanka	SE	Sweden		
EE	Estonia	LR	Liberia	SG	Singapore		

FLUID CONNECTIONS

The present invention relates to fluid connections, in particular to a fluid
5 connection between an inlet capillary or other small bore tube and a microengineered
fluidic structure. Hereinafter the term "small bore tube" is taken to include capillary
tubes and non-capillary tubes.

There is a growing interest in microengineered structures for transporting
microscopic amounts of fluid, wherein the fluid is subject to chemical and/or
10 biochemical processing and analysis. In particular our copending application
WO96/12541 describes and claims method and apparatus for carrying out a diffusive
transfer process between first and second immiscible fluids, wherein first and second
flow paths communicate with one another in a region which is such as to permit the
fluids to form a stable open interface therein, and wherein the flow paths in the interface
15 region have a width normal to the interface within the range 10 to 500 micrometers. As
described, the apparatus is typically constructed by etching grooves in the surface of a
silicon sheet, to form fluid flow channels, and to bond a cover layer of glass onto the
silicon sheet. However the application does not address in detail the problem of making
an external connection to the microengineered device. It is desirable in this and many
20 other applications of microfluidic devices, especially for analysis or where fluids within
the devices are to be monitored or controlled, that connections be formed to external
tubing without formation of excessive dead spaces or stagnant areas. This can require
connection of the microfluidic device channels to capillary tubing of similar cross
sectional dimensions.

25 Methods of making connections to capillary tubes are extremely well
documented and are very diverse, depending on the specific application. For example,
an end of the glass capillary may be surrounded by a plastic sheath for fixing securely in
an inlet aperture of an apparatus, see for example EP-A-0698789 which describes a
connection of capillary tubing to high pressure liquid chromatography apparatus.
30 However, making a force fit with a flexible sheath or other insert would not be suitable
for such a delicate microengineered structure as described in our above copending
application. Further conventional connector structures for connection to circular cross
section capillary tubes by conventional procedures require structures with a recess of
circular cross section, sometimes tapered, which are generally unavailable with
35 microengineered devices, and generally with dimensions greater than the thickness of
substrates conventionally used for construction of microengineered structures. For the
purposes of the specification, microengineered structures is intended to mean structures
formed with one or more than one stacked substrates, each substrate being of generally

planar form and of a thickness preferably 2 mm or less, and having fluid flow channels formed therein, at least parts of such channels having a cross-sectional diameter less than 1000 micrometers. It will be understood that diameter is intended to mean the thickness or width for non-circular cross sectional channels. It will further be appreciated that such channels may be extended in specific regions to form chambers etc. within the structure with dimensions greater than 1000 micrometers. The substrates are commonly formed from silicon, glass, ceramics, plastics or metal.

Connection of capillary tubes (commonly having dimensions between 50 and 1000, desirably between 100 and 300 micrometers external diameter) to microengineered structures, especially those formed by bonding planar etched or formed substrates, generally requires low stress joining techniques. High temperature processes such as required to weld metals, ceramics, or glasses may generate damage such as substrate cracking or delamination. Within relatively thin (generally < 2mm) substrates, especially in ceramics or glass, the formation and maintenance of threaded, interference, or compression joints is not well established. Sealing of joints usually therefore requires use of sealing material.

In Reston & Kolesar "Silicon-Micromachined Gas Chromatography System - Part 1", Journal of Micromechanical Systems, IEEE/ASME, December 1994, page 139 there is shown a method of connecting a gas inlet tube to a gas chromatograph comprising a spiral flow path, 300 μm wide and 10 μm deep, etched into the surface of a silicon wafer substrate. A glass plate is bonded to the upper surface of the substrate over the spiral flow path, and a tapered gas feed through an aperture is formed in the lower surface of the silicon wafer communicating with the spiral flow path. An end of a gas inlet tube, 254 μm in diameter, is inserted into the tapered aperture, and an adhesive (epoxy resin) is applied around the end of the inlet tube and the open part of the aperture in order to seal the tube within the aperture.

There are a number of problems and disadvantages associated with such an arrangement where the capillary tubes enters the device perpendicular to the plane of substrates and the fluidic structures formed in those substrates. One problem is that having a capillary tube connection perpendicular to planar substrates and devices interferes with stacking of such substrates and devices to produce compact systems. Another problem is that formation of vias through substrates for connection of capillary tubes perpendicular to substrates can excessively complicate device fabrication and reduce achievable device density and yields. Formation of vias through substrates with near parallel or slightly tapered bores matched to capillary tube dimensions can be difficult. For structures etched in glass or silicon the masking and etch time requirements for the deep etching required for formation of such vias can be much more restrictive than those required for etching the fluidic channel structures into the substrate surface.

Another problem with such an arrangement is that the length of capillary tube enclosed within the substrate is limited to the thickness of the substrate, and that the length of adhesive bond supported intimately by the outer wall of the capillary tube and bore through the substrate is similarly limited to the thickness of the substrate. This can result in a relatively weak and fragile seal. Application of further adhesive around the capillary and onto the outer surface of the substrate may improve seal quality, but the improvement is often limited by poor bonding to planar substrate surfaces. Application of further adhesive around the capillary and onto the outer surface of the substrate may also be undesirable due to the resultant increase in unit volume and interference with packing together of units into a system. Similarly, bonding of conventional capillary connectors onto the substrate surface over a via may give poor seal quality, increase the area required for individual devices, and interferes with device packing and stacking

Another problem with such arrangements is that feeding adhesive materials into the region between the capillary tube outer wall and the sides of the via bore sufficiently well to form a seal, but without adhesive entering and blocking or contaminating the fluidic channels and the capillary tube itself, can be difficult. It is generally necessary to use adhesive formulations of sufficiently high viscosity to prevent rapid flow of adhesive by capillary action into the fluidic channels. It is, however, generally difficult to observe or monitor and control how well the adhesive has fed into the via regions desired.

A further problem with such arrangement is, particularly for gases, that the fluid must flow into the microengineered structure in a direction perpendicular to the direction of the fluid channels within the structure and that the movement of the fluid through a right angle may create turbulence or other recirculating or mixing processes and create flow conditions which are difficult to predict.

Summary of the Invention

In a first aspect the present invention provides a method of connecting a capillary or other small bore tube to a microengineered structure to serve as a fluid flow port therefor, comprising;

- (1) providing a microengineered structure having at least a first substrate with fluid flow channels formed therein, the or each substrate being defined by first and second opposite side surfaces and end surfaces extending from the edges of the side surfaces, and wherein an end surface of the at least one substrate has an aperture therein communicating with a said fluid flow channel;
- (2) providing a capillary tube or other small bore tube and inserting an end thereof into said aperture in said end surface; and

(3) flowing within the aperture around the tube a sealant material, which is then hardened in order to seal the tube within the aperture.

The present invention provides in a further aspect an apparatus comprising a microengineered structure having a fluid coupling, the structure comprising at least a first substrate with one or more fluid flow channels formed therein, the or each substrate being defined by first and second opposite side surfaces and end surfaces extending from the edges of the side surfaces, and including fluid inlet means comprising a capillary tube or other small bore tube inserted into an aperture formed in an end surface of the at least one substrate, which communicates with a said fluid flow channel, and wherein a sealant material is provided in the aperture, having been hardened in situ around the tube in the aperture subsequent to insertion of the tubing in the aperture.

In a further aspect, the invention provides a microengineered structure for a fluid coupling as set forth above wherein the structure comprises at least a first substrate with one or more fluid flow channels formed therein, the or each substrate being defined by first and second opposite side surfaces and end surfaces extending from the edges of the side surfaces, an aperture being formed in an end surface of the at least one substrate and communicating with a fluid flow channel and being dimensioned for receiving a capillary or other small bore tube.

The diameter of said aperture is sufficient to allow insertion of the tube (which may be 1000 micrometers diameter) together with sealant material around the tube, and may be different to the fluid flow channel diameter. Said aperture is such that the tube is positioned in the same plane and preferably the same direction as a fluid flow path of the structure, where the aperture is formed by a straight or gently curved guide channel running from a fluid flow channel to a substrate end surface.

As is common in microengineered structures, fluid flow channels may be formed in the surface of a first substrate, and a second substrate is stacked on the first substrate in order to seal the fluid flow channels. Alternatively the second substrate may have fluid flow channels formed in its lower surface which may communicate and co-operate with the flow channels in the upper surface of the first substrate. As an alternative arrangement, the fluid flow channels may be formed within the bulk of the first substrate, and a second substrate is not necessary for defining or sealing the fluid flow channels. In a further arrangement, the fluid flow channels and said aperture may be formed by building successive layers on top of an initial substrate, the substrate with such layers then defining said first substrate, with a second substrate preferably sealing the top of the fluid flow channels.

Fluidic channels on microengineered structures, and guide channels for tube connections when formed on and between plane substrates will not generally be of circular cross section to match the connecting tubes. Etched, milled or sawn channels

may generally have cross sections of approximately semicircular, triangular, trapezoid, or rectangular forms. Superposition of semicircular channels in first and second substrates may yield approximately circular cross sections, but misalignment and deviations from symmetry of a few micrometers at least are to be expected. It is a requirement therefore that sealant for tubes connected into guide channels in the substrate plane must fill significant spaces around the tubes.

In accordance with the invention a means is provided of establishing a fluid flow connection to a microengineered structure, where the fluid may flow directly into the structure in a direction parallel with the fluid flow channels within the structure. Thus there is no turbulence or other unpredictable flow conditions created. Further, since the seal is created subsequent to insertion of the tube by addition or formation of a sealing material between the outer walls of the capillary tube and the inner wall of a channel section formed to contain the capillary tube, there is no excess pressures or thermal or other stresses created which might fracture the microengineering structure or cause a faulty seal.

An advantage of the invention is that the capillary tubes connect in the plane of the microengineered device allowing devices to be stacked. A further advantage is that the length of seal around the capillary tube within the device can be selected at the design stage without the constraint of the substrate thickness and can be made sufficient to assure a good seal. A further advantage where one or more substrates is transparent is that the extent of the seal can be observed and radiation curing low viscosity capillary filling sealant may be employed. A further advantage with some embodiments is that through vias do not need to be formed in the substrates. Where vias are proposed as described below for sealant feeding, they may be remote from the microengineered fluidic structures and need not be formed to the precision required for connectors perpendicular to the substrate.

In addition to providing external fluid connections to microengineered fluidic devices, a means is provided for linking fluid flow channels in separate microfluidic devices which may be on separate substrates or may share one substrate or may be on a series of overlapping substrates bonded together.

The sealant material may comprise a substance, or mixture of substances, as will become clear below. The sealant material will be selected from substances such as adhesives or cementing materials. These most generally will be organic materials such as epoxy resins, but may include other polymeric or polymerisable materials including inorganic materials or components.

In one preferred embodiment, the seal is formed by a method as described and claimed in our European Patent Number EP-B-319175 (our Ref PA1314); the patent describes and claims a method of forming a solid article of predetermined shape from a

liquid which can be cured by exposure to radiation, the method comprising the steps of providing a surface upon which the article is to be formed; exposing a predetermined region of the surface to a beam of radiation; supplying the liquid to an unexposed region of the surface such that a solid barrier, defining a surface of the solid article, is created at the interface of the liquid and the beam, and curing the liquid which has been supplied but not yet cured to form said solid article.

Thus to apply such a method to the present invention, a microengineered structure with fluidic channels in the substrate plane is fabricated with fluidic channels connecting as desired with straight or gently curved guide channels also in the substrate plane which run to a substrate edge. The cross section of the guide channels is large enough to allow tube insertion at the aperture formed at a substrate edge and for the capillary tube to be fed into the structure to connect with the fluidic channels. A beam of, for example, ultra violet radiation is applied through a transparent substrate material adjacent to the end of a capillary tube positioned within an end aperture in a microengineered structure at the end limits of the desired position of the sealing substance. A radiation curing sealing substance is then fed into the open end of the guide channel so that the liquid sealant flows around the tube and into the aperture. The flow of liquid sealant may be driven by hydrostatic or other applied pressure or by capillary forces or a combination of these forces. When it reaches the beam of radiation, it is hardened and cured. When a solid plug is created at the end, the beam may then be moved through the uncured substance so as to create a completely hardened plug. Alternatively, the remainder of the substance may be cured by broad exposure to UV or light, or by the application of heat.

Brief Description of the Drawings

Preferred embodiments of the invention will now be described with reference to the accompanying drawings wherein:-

Figure 1 is a schematic plan view of a microengineered structure according to the invention with first and second fluid couplings providing input and output ports;

Figure 2 is a schematic side sectional view showing the method by which a first fluid coupling of Figure 1 is formed;

Figure 3 is a schematic side sectional view showing the method by which a second fluid coupling of Figure 1 is formed;

Figures 4 and 5 are schematic side sectional views of the second fluid coupling of Figure 1 and a modification thereof;

Figures 6a - 6h are cross sectional views along the line 6 - 6 of Figure 1 for various cross sections of fluid flow channels:

Figures 7 and 8 are schematic side sectional views of methods of forming respective second and third embodiments of the invention;

Figures 8 - 12 are schematic side sectional views of methods of forming respective fourth to seventh embodiments of the invention, and

5 Figures 13a - 13c are views illustrating a method in accordance with an eighth embodiment of the invention.

Description of the Preferred Embodiments

10 Referring now to Figure 1 to 6, there is shown a microengineered structure comprising a first silicon substrate 2 and a second glass substrate 4 (Figure 6) positioned face to face with the first substrate. The substrate 2 is defined by upper and lower opposite side surfaces and end surfaces extending from the edges of the side surfaces. First substrate 2 has a serpentine fluid flow channel 6 formed in the upper surface
15 thereof extending from an inlet port 8 to an outlet port 10, both formed in an end surface 11 of the substrate. It will be understood that the fluid flow channel may take various forms, depending upon the application, for example, large area chambers etc. Fluid flow channel 6 has a diameter, width or thickness less than 1000 micrometers, typically 100 micrometers, and may be of any suitable shape, for example triangular cross section.

20 Fluid inlet port 8 and fluid outlet port 10 are both formed with apertures 12 formed in end surface 11 and having the form of bores, having a width, as shown more than twice that of channel 6. Apertures 12 receive capillary tubes 14 which may have a variety of sizes, for example 300 micrometers external diameter, 200 micrometers internal diameter, or 200 external, 150 internal, or 100 external 50 micrometers in
25 diameter. The cross sectional shape of bores 12 may take a variety of forms as shown in Figure 6 namely (a) triangular, (b) truncated triangular, (c) semi circular, (d) rectangular, and (e) circular. It will be noted that in Figure 6 all of the bores 12 are formed in the upper surface of substrate 2 apart from the circular bore of Figure 6e which is formed partly in substrate 2 and partly in the lower surface of substrate 4, but in general the bore
30 could be formed in either substrate. An alternative construction is shown in Figure 6f and 6g wherein a circular bore is formed wholly within substrate 2 by an etching technique involving cutting a vertical slit 19 in the upper surface of substrate 2 and then generating a circular bore by an etching technique. The slit will be sealed with sealant material 18 in the finished form of the fluid coupling, as shown in Figure 6g.

35 In Figure 6h an alternative construction is shown wherein bore 12 and fluid flow channels 6 are formed on the upper surface of base substrate 2 by building, by any suitable microengineering technique (defined by printing, photolithography, lamination, and modified by etching if required), layers 20 which define the side walls of the bore

and fluid flow channels. The lower surface of the bore is defined by the upper surface of base substrate 2 and the upper surface of the bore is defined by the lower surface of substrate 4 which is subsequently bonded to layers 20. In such an arrangement, the upper surface of the layers 20 define, in part, the upper surface of said first substrate.

5 For the sake of explaining the invention, the fluid coupling to inlet port 8 is formed differently from that to outlet port 10. Referring to Figure 2 which shows the method of forming the fluid coupling with inlet port 8, capillary tube 14 is first inserted in to bore 12 close to a point where bore 12 merges with flow channel 6 at a shoulder 16. Capillary tube 14 may be formed of silica, but may be glass, polymer or even metal. A
10 radiation curable material 18 is flowed into the open end of bore 12 and is such as to wick along bore 12 towards the end of tube 14. A beam of ultra violet radiation 22 is directed at the end of tube 14 from a light source 24 through transparent glass substrate 4 so that when the liquid reaches the beam it is hardened. Once a solid plug has been formed at the end of the tube 14, the light source may be moved along the length of the
15 tube so as to cure and harden the remainder of liquid 18. Alternatively a second light source (not shown) is provided for general exposure of the liquid 18.

In a variation of the method as shown in Figure 3 which is adopted for outlet port 10, a through aperture or via 30 is provided into which the radiation curable material is flowed. Otherwise the method is similar to that shown in Figure 2. The advantage of
20 having a separate inlet via 30 for the radiation curable material is where the material is not sufficiently fluid to permit it to be flown from the end of fluid inlet port 8.

Referring to Figures 4 and 5, it is necessary when flowing material into the fluid inlet port 8 to avoid injection of excess material, which may flow into the fluid flow channel 6 and block the channel. Control is usually exercised by physical observation of
25 the amount of material injected. In Figure 4, a via 30 is positioned approximately mid way between the open end of the bore and fluid flow channel 6. When sealant material starts emerging from the open end of the bore, as shown by swelling 40, an observer will know that the material has also reached the inner end of tube 14, and that further injection of material should be stopped.

30 In Figure 5 an alternative arrangement is shown for injecting a smaller amount of material, wherein a second via 50 is provided communicating with the bore and positioned adjacent to via 30. During inflow of sealant material through via 30, an observer observes the ingress of sealant material into via 50, as shown by swelling 52, and at that point will appreciate that a sufficient amount of sealant material has been
35 inserted and has reached the inner end of tube 14.

The radiation curing material may most generally be a UV or light curing polymeric material. A variety of UV curing acrylic materials with a range of viscosities are available commercially (Norland UV Sealants, Norland Products Inc., New

Brunswick, N.J. 08902, USA) and examples from that range (e.g. high viscosity Norland 91, low viscosity Norland 81) or similar materials may be selected for use in the methods described below where one or more of the substrate materials is transparent to the radiation.

5 Feeding sealant into the aperture at a substrate edge is particularly convenient for low viscosity sealant which feeds into the guide channel by capillary action. For such low viscosity sealant it is necessary to provide a means of curing the sealant at the desired position in the guide channel by, for example, UV radiation so as to prevent the sealant running beyond the tube end and into the tube and the fluidic structure. For
10 sufficiently viscous sealant, where flow is only significant under applied pressure, curing may also be by radiation, but use of non-radiation curing sealant is also possible. Where a sufficiently viscous sealant, especially a viscoelastic formulation, is employed such that flow within the guide channel is insignificant under capillary action but may be produced by pressure applied to the sealant at the aperture at a substrate edge, or by
15 vacuum applied within the microengineered structure, flow may be stopped by removing the pressure differential and the sealant cured or allowed to cure. An example is high viscosity two part epoxy which may be applied in e.g. Ciba Geigy Araldite 2005. The removal of the pressure differential may be in response to observation of the sealant front in the guide channel, or by observing sealant extruding from the channel, possibly
20 automated with the aid of a vision system, or after a known time determined to produce the required amount of flow. The arrangements of Figures 4 and 5 would be particularly suitable.

Where sufficient thermal control can be applied to parts of the structure, a molten sealant material may be used which solidifies at the desired position within the guide
25 channel.

Referring to Figure 7 and 8, these show a modification of the method of Figure 4 wherein an insert rod member 70 is inserted into tube 14 so as to project beyond the end thereof into fluid flow channel 6. In Figure 7, bore 12 and channel 6 are formed equally in substrate 2 and substrate 4, whereas in Figure 8, bore 12 and channel 6 are formed
30 wholly in substrate 2. Figures 7 and 8 show a method for allowing sealant to go beyond end of the tube and reduce dead space. The insert 70, e.g. rod, fibre (possibly optical), wire, or narrower tube, is passed through tube 14 and into fluid channel 6. The sealant is allowed to flow beyond end of connection tube 14 and around insert 70 before curing. The insert is removed by pulling out (e.g. for tungsten wire, or optical fibre, possibly
35 coated with release agent), or melting (e.g. for polypropylene or PMMA fibre or rod, or Indium wire), or dissolving (e.g. for Cu or Ni tubes).

Referring now to the embodiment shown in Figure 9, the substrates 2, 4 are of an opaque material. To permit the use of radiation (e.g. UV) curing sealant, the radiation

beam 90 is carried into the structure by an optical fibre 92 which is passed inside tube 14 which is transparent. Alternatively, the fibre could be passed through the flow channels 6. Thus the coupling is formed as described above with reference to Figure 2 but with the fibre optic 92 inserted in the tube 14 and positioned so that the region 94 at the end of the tube is bathed in radiation. Radiation curing sealant 18 flows up the guide channel towards the end of the tube and is cured by the radiation, thus preventing sealant passing into tube and fluidic channels. After forming a plug in region 94, the fibre optic is withdrawn slowly irradiating the rest of the sealant through the tube wall.

Referring now to Figure 10, this shows a method for precipitant sealing by flowing two liquids into the system which react to form a solid. Thus, for example, concentrated viscous sodium silicate solution 100 is fed in through via 102, while a much less viscous solution 104 of for example a calcium or magnesium salt (e.g. CaCl_2) is fed in through tube 14. An insoluble silicate precipitate is formed at region 108 at the end of the tube. By adjusting concentrations and flow rates it is ensured that the precipitate remains in bore 12 around tube and progressively gets denser as Ca^{2+} ions diffuse into the silicate, while any precipitate formed in the solution flowing through the centre of tube 14 gets swept away by force of flow.

Referring to Figures 11 and 12, these are similar to Figures 7 and 8 except that both substrates 2, 4 are opaque and it is therefore necessary to use a viscous, preferably viscoelastic material 110 which can be injected into via 30 under pressure and which sets upon the release of pressure and/or the application of heat.

In a further modification (not shown), of Figures 7 and 8, the capillary tube is dispensed with, and the sealing material is grown on the outside of aperture 12 so as to boss onto which an external connection may be made.

Referring now to Figures 13a to 13 c, these show an eighth embodiment of the invention wherein a tube 14 has a preformed sleeve insert 130 formed around its inner end and of an external diameter less than that of bore 12. This allows free insertion of tube 14 within the bore as shown in Figure 13a. When fully positioned in the bore, heat is applied which causes the insert material to melt and form a seal between the tube 14 and the inner walls of the bore 12 as shown in Figure 13b.

In Figure 13c, a sleeve insert material material 132 is provided which expands after insertion by application of a chemical reactant to change the composition of the material, e.g. iron expanding to iron oxide.. Upon the removal of heat, the sealant material remains in the position shown in Figure 13c.

It will be appreciated that in the embodiments of Figure 13 and 10, in particular, that where a plug is formed at the end of the tube, the remainder of the bore may subsequently be filled with a sealant material injected and hardened in accordance with any of the other embodiments, for example that in Figure 2.

In addition, alternative sealants to radiation curable sealants may be employed. For example, an anaerobic curing sealant which cures within the bore around the tube could be used, in which case sufficient control on the sealant flow rate and/or cure time is needed, and also, possibly a flush device with nitrogen or other oxygen free gas.

- 5 Alternatively the sealant material could be a viscous ceramic cement inserted by way of a via, as described with reference to Figure 3. Example of such ceramic cements are Portland cement, plaster of Paris paste (hydrating gypsum CaSO_4), or phosphate cement (e.g., based on aluminium orthosposphate solution and MgO).

CLAIMS

1. A method of manufacturing a fluid connection between a small bore tube and a
5 microengineered structure to serve as a fluid flow port therefor, comprising;
- (1) providing a microengineered structure having at least a first substrate with fluid
flow channels formed therein, the or each substrate being defined by first and second
opposite side surfaces and end surfaces extending from the edges of the side surfaces,
and wherein an end surface of the at least one substrate has an aperture therein
10 communicating with a said fluid flow channel;
- (2) providing a capillary tube or other small bore tube and inserting an end thereof
into said aperture in said end surface; and
- (3) flowing within the aperture around the tube a sealant material, which is then
hardened in order to seal the tube within the aperture.
- 15
2. A method as claimed in claim 1, wherein the substance comprises a radiation
curable material and a beam of radiation is directed at the inner end of the tube within
the aperture so that as the curing material is introduced into the aperture, it hardens upon
reaching the beam of radiation.
- 20
3. A method as claimed in claim 2, wherein once a solid plug is formed at the end
of the tube, the beam is moved along the tube to harden the remainder of the material
within the aperture.
- 25
4. A method as claimed in claim 3, wherein a substrate is of a transparent material
and the beam of radiation is directed through the substrate, or the tube is of a radiation
transparent material and radiation is directed at the curing material via the tube.
5. A method as claimed in claim 1, wherein the substance is viscous, preferably
30 viscoelastic or pseudoplastic, and is flown into the aperture under pressure, subsequent
removal of the pressure allowing the substance to harden.
6. A method as claimed in claim 1, wherein the substance is inserted into the tube in
a molten form, subsequent cooling of the substance permitting it to harden.
- 35
7. A method as claimed in claim 1, wherein the substance is a cement inserted into
the aperture in a fluid form, and subsequently hardened.

8. A method according to claim 1, wherein a first substance is introduced in said aperture, and a second substance is introduced through said tube, the two substances mixing and reacting at the inner end of the tube in order to create a seal within the aperture around the tube.
- 5
9. A method according to claim 1, wherein a substance is formed as a cylindrical insert on the end of the tube of an external dimension to permit free insertion of the tube in the aperture, and melting the insert when the tube is inserted in the aperture to seal the tube to the inner surface of the aperture.
- 10
10. A method as claimed in any preceding claim, wherein a substrate has a via formed therethrough to communicate with said aperture in order to permit flow of the substance therethrough to said aperture.
- 15
11. A method as claimed in any preceding claim, wherein the amount of material flown into the aperture is determined by physical observation of the material within the aperture.
- 20
12. A method as claimed in claim 11, wherein a further via is provided in a substrate communicating with said aperture to permit observation of sealing material flowing along the aperture and into the further via in order to determine that sufficient material has flown into the aperture.
- 25
13. A method as claimed in any preceding claim, wherein an insert member is inserted through the tube into the fluid flow channel in order to permit the substance to be flown into said aperture as far as the connection with the fluid flow channel without blocking the fluid flow channel, the rod being withdrawn from the tube subsequent to hardening of the substance.
- 30
14. A method according to claim 13, but modified in that the capillary tube is dispensed with.
- 35
15. A fluid connection between a small bore tube and a microengineered structure, said structure having at least a first substrate with one or more fluid flow channels formed therein, the or each substrate being defined by first and second opposite side surfaces and end surfaces extending from the edges of the side surfaces, and including fluid inlet means comprising small bore tube inserted into an aperture formed in an end surface of the at least one substrate, said aperture communicates with a said fluid flow

channel, and wherein a sealant material is provided in the aperture, having been hardened in situ around the tube in the aperture subsequent to insertion of the tubing in the aperture.

- 5 16. A microengineered structure as claimed in claim 15, wherein the structure comprises at least a first substrate with one or more fluid flow channels formed therein, the or each substrate being defined by first and second opposite side surfaces and end surfaces extending from the edges of the side surfaces, an aperture being formed in an end surface of the at least one substrates and communicating with a fluid flow channel
10 and being dimensioned for receiving a capillary or other small bore tube.

17. Apparatus or method according to any preceding claim, wherein the aperture is formed by a straight or gently curved guide channel or bore running from a fluid flow channel to said end surface.
15

Fig.1.

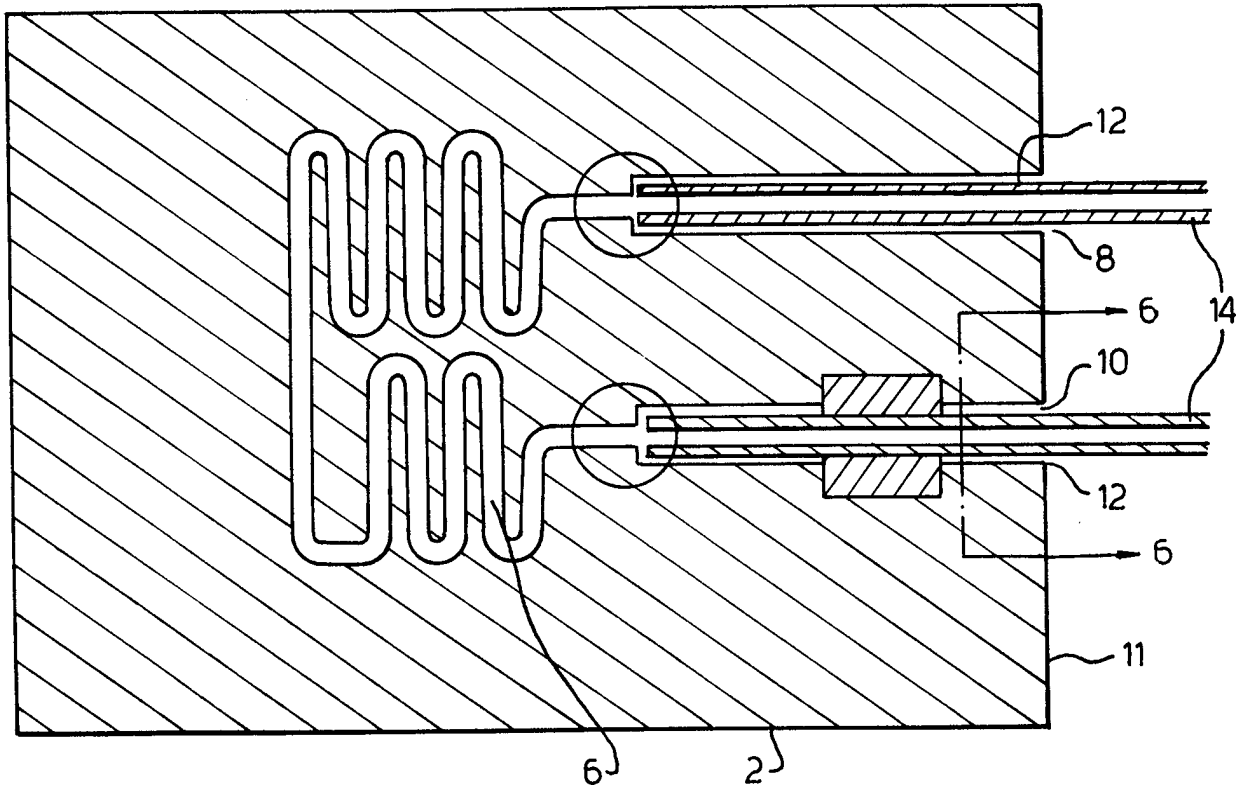
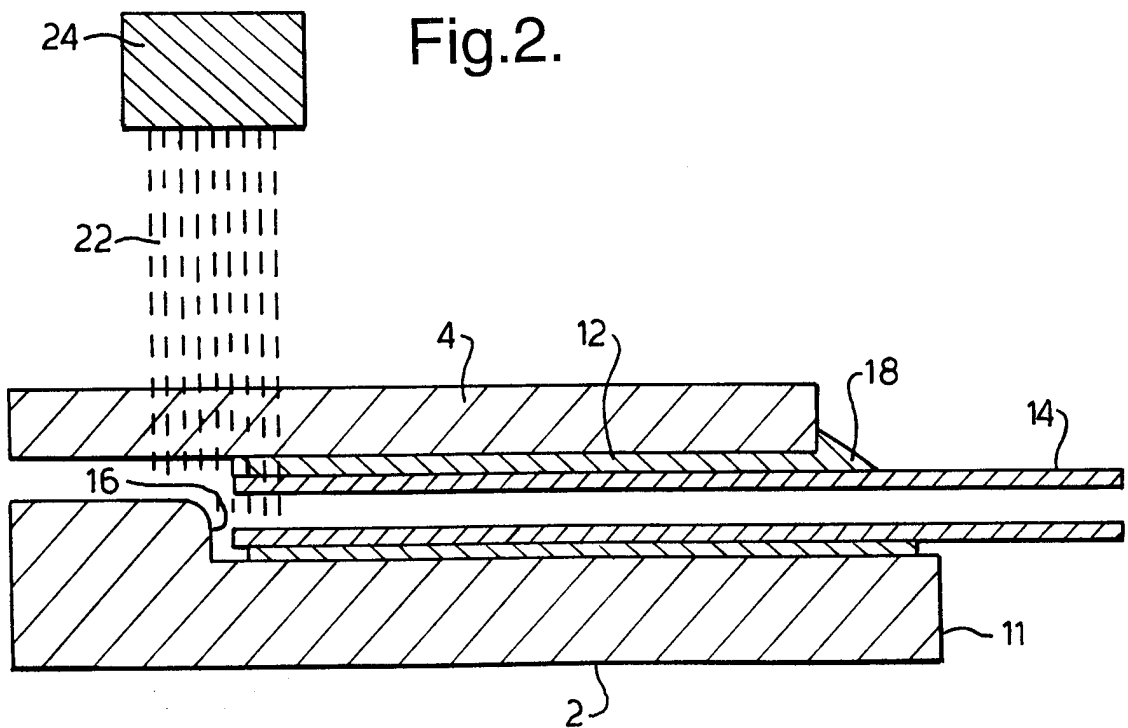

Fig.2.



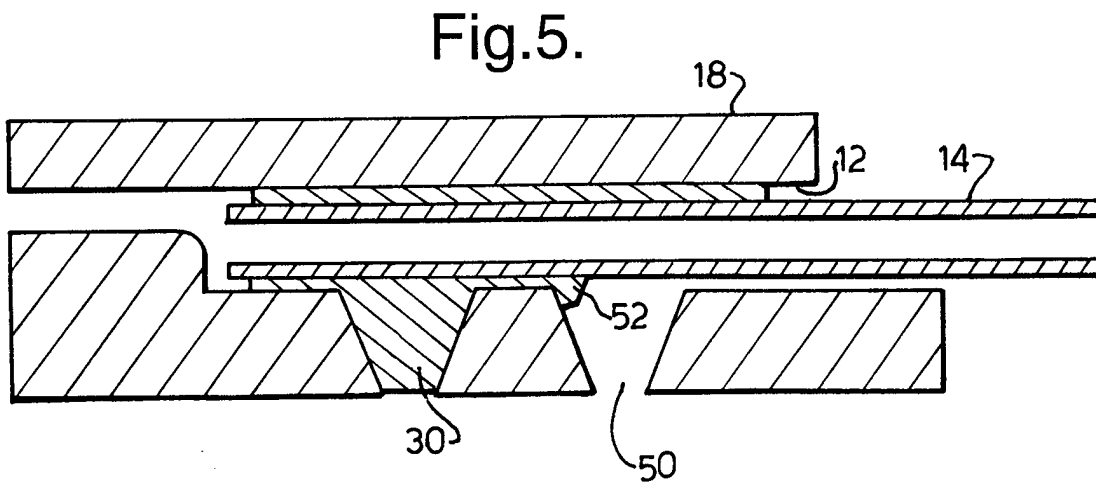
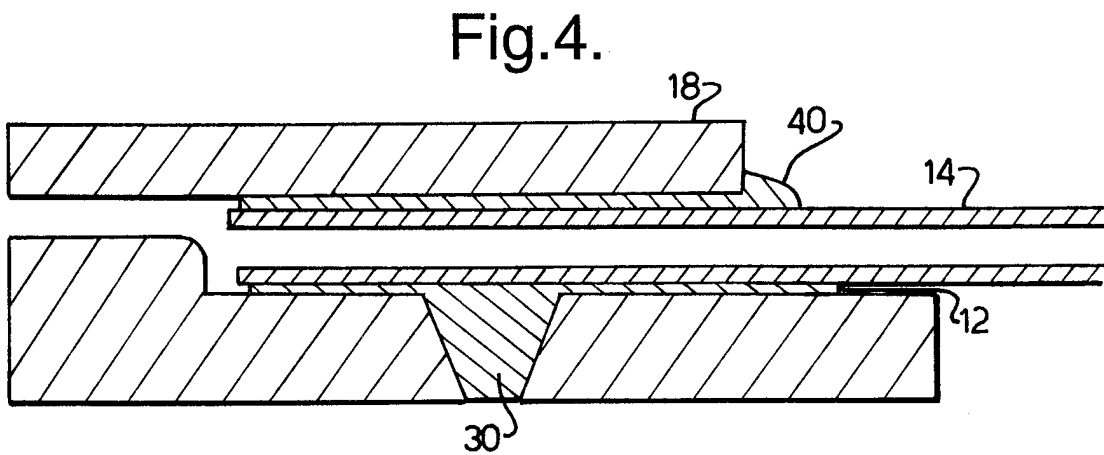
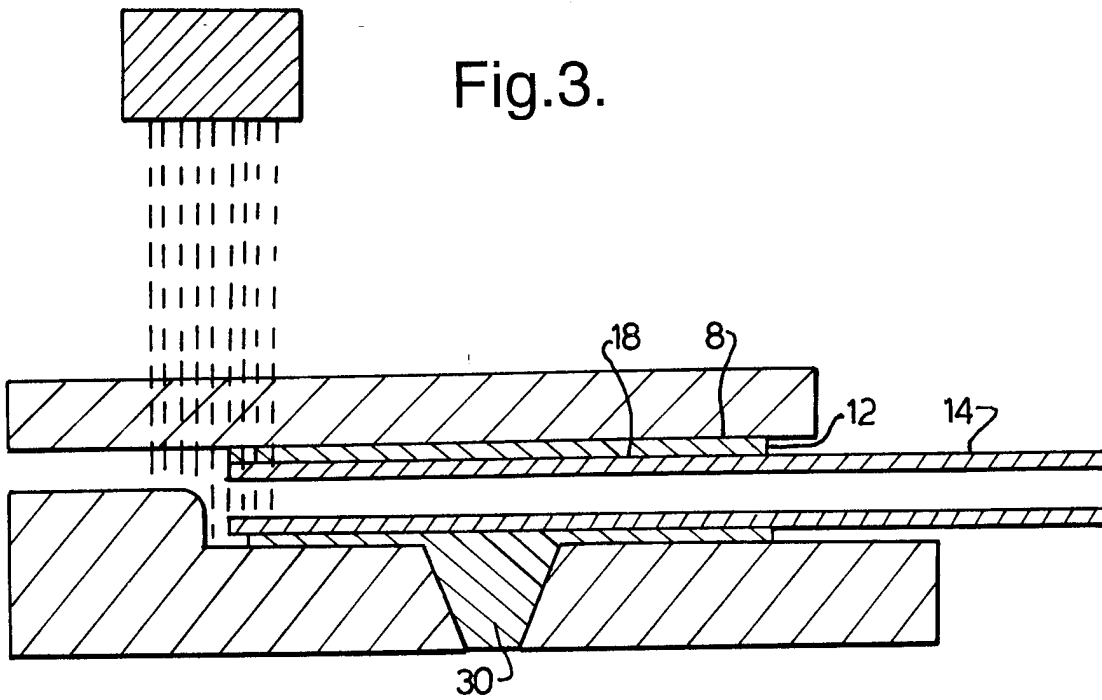

Fig.6a.

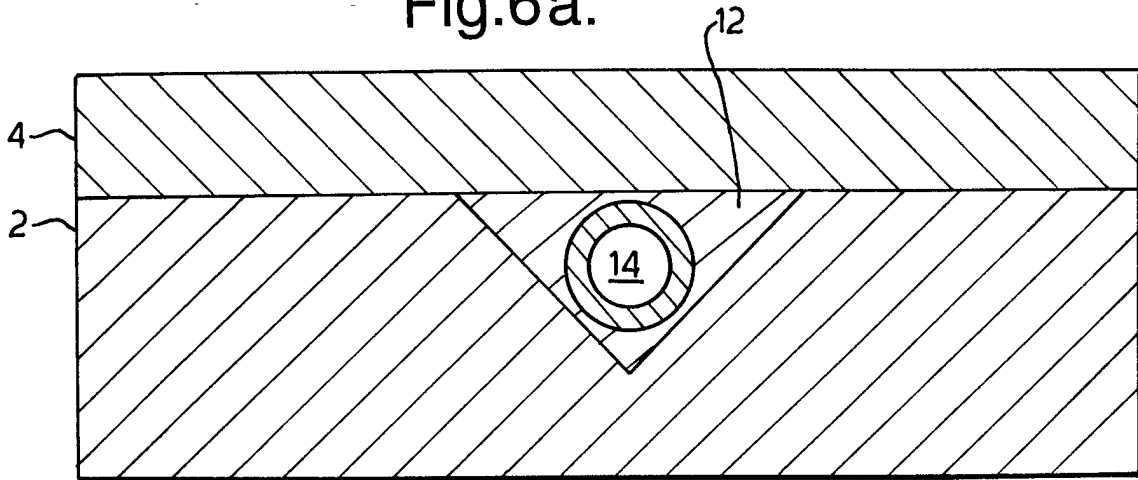

Fig.6b.

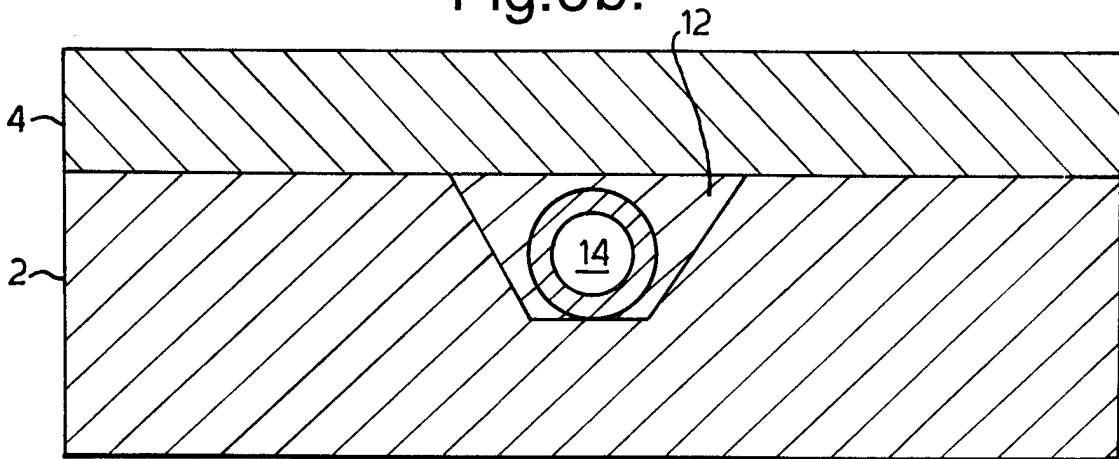

Fig.6c.

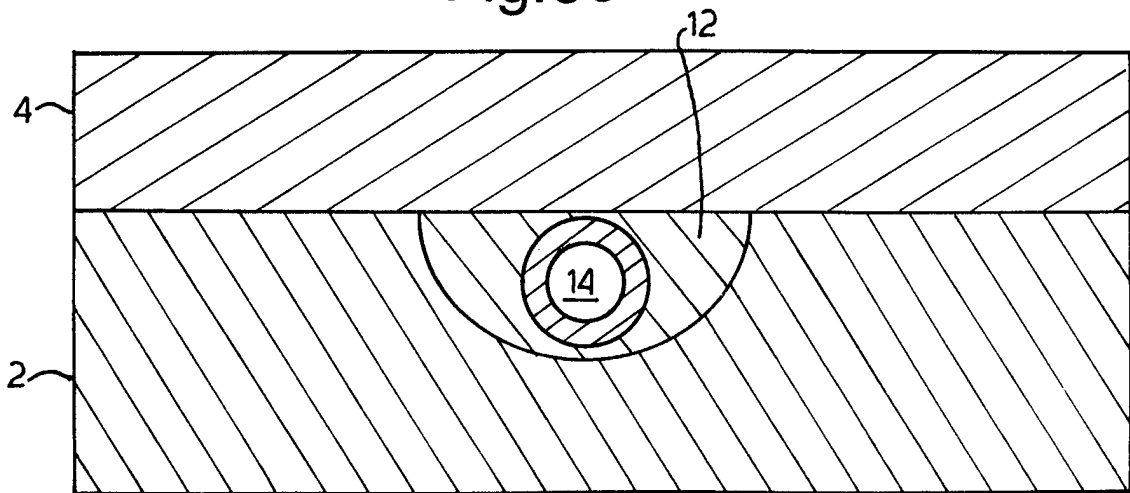

Fig.6d.

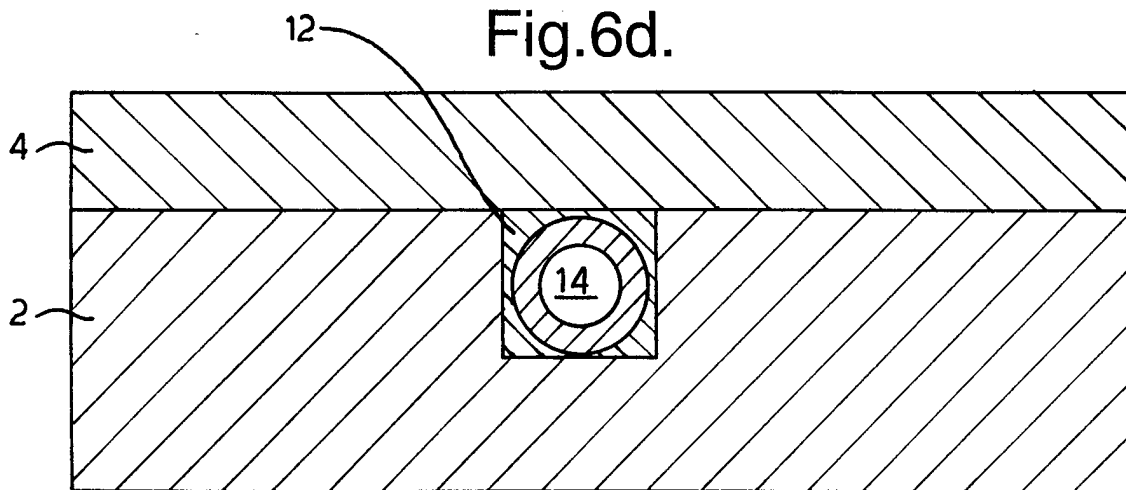

Fig.6e.

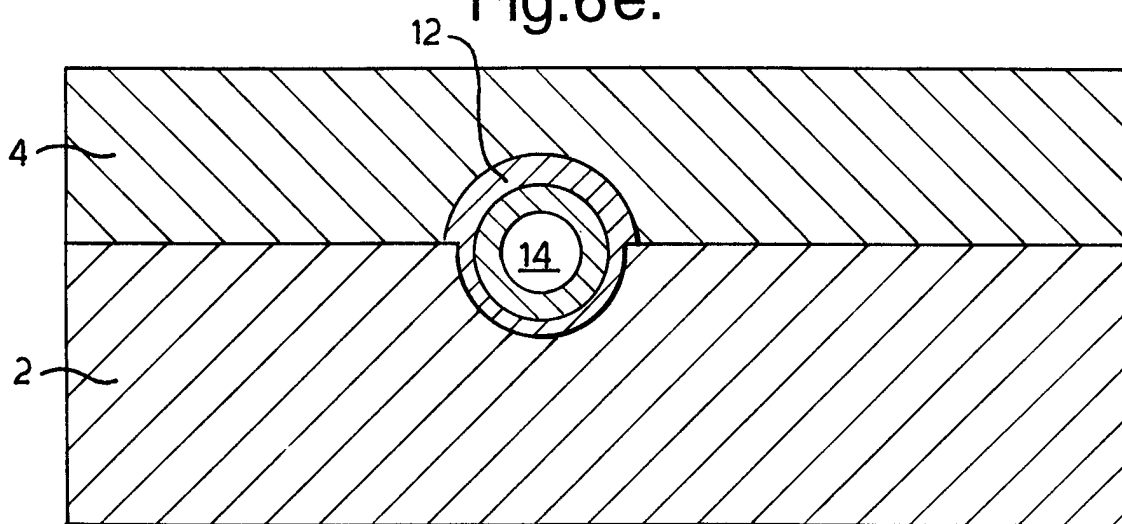

Fig.6h.

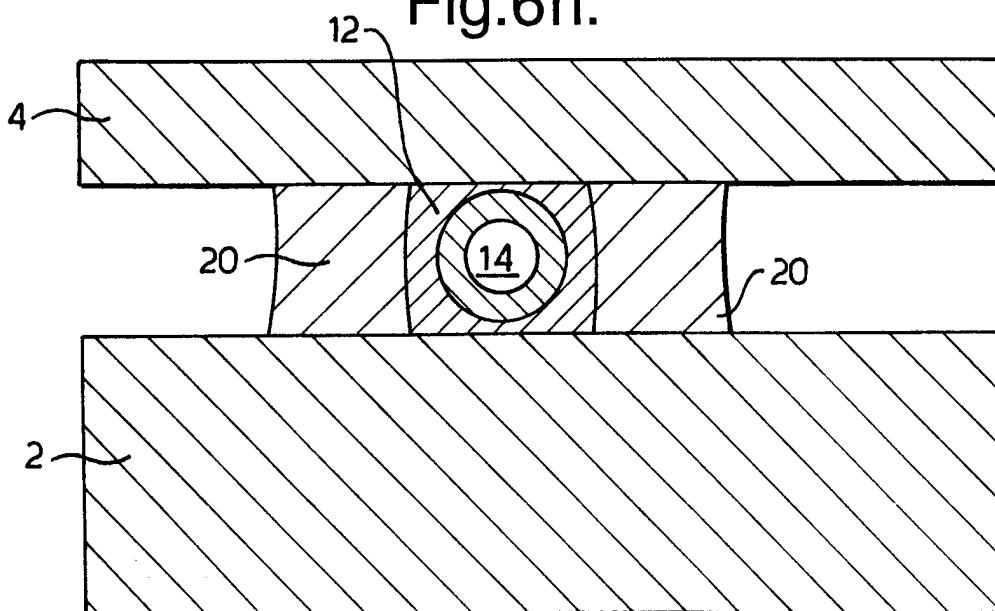

Fig.6f.

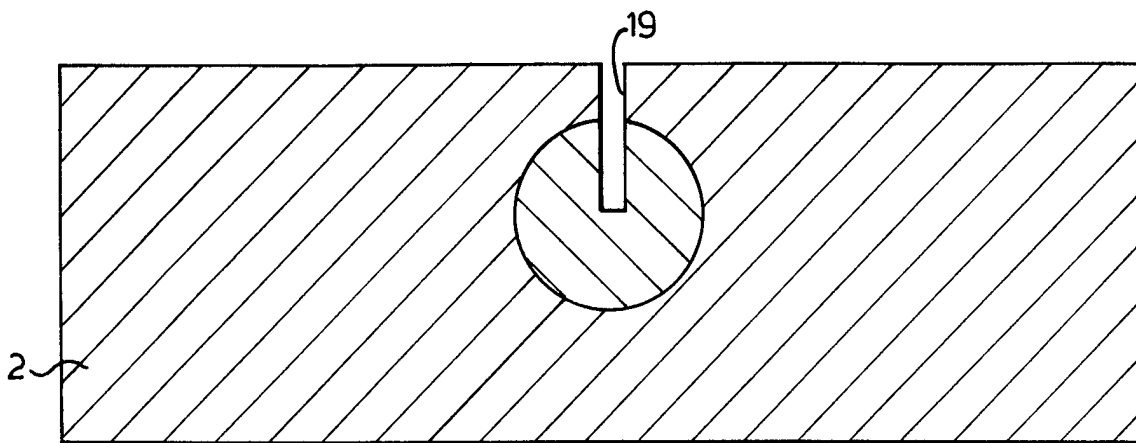
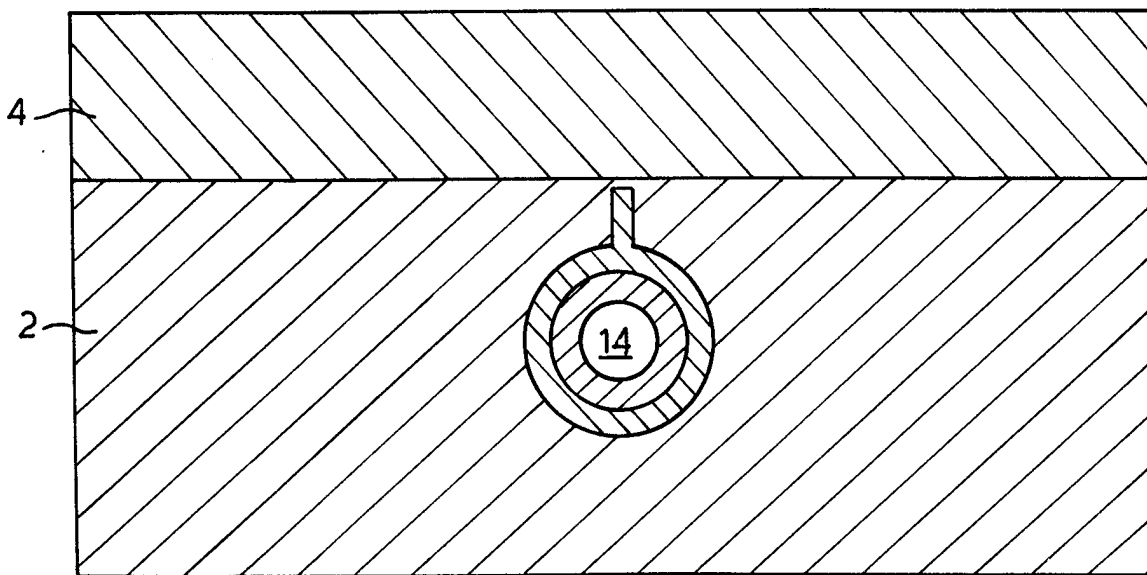

Fig.6g.



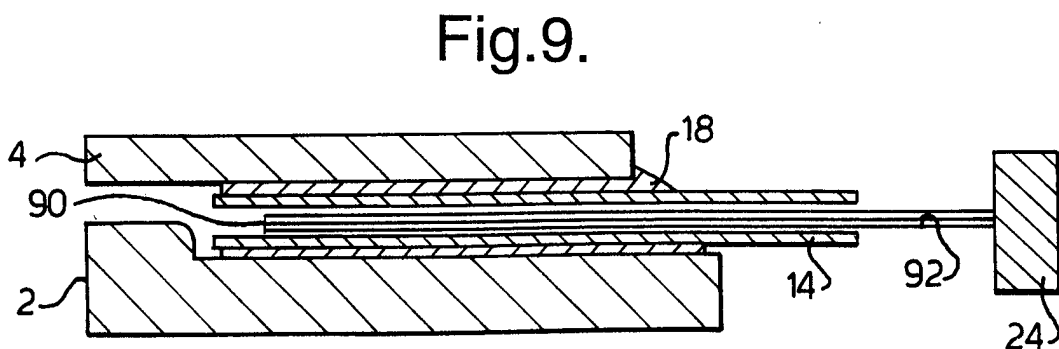
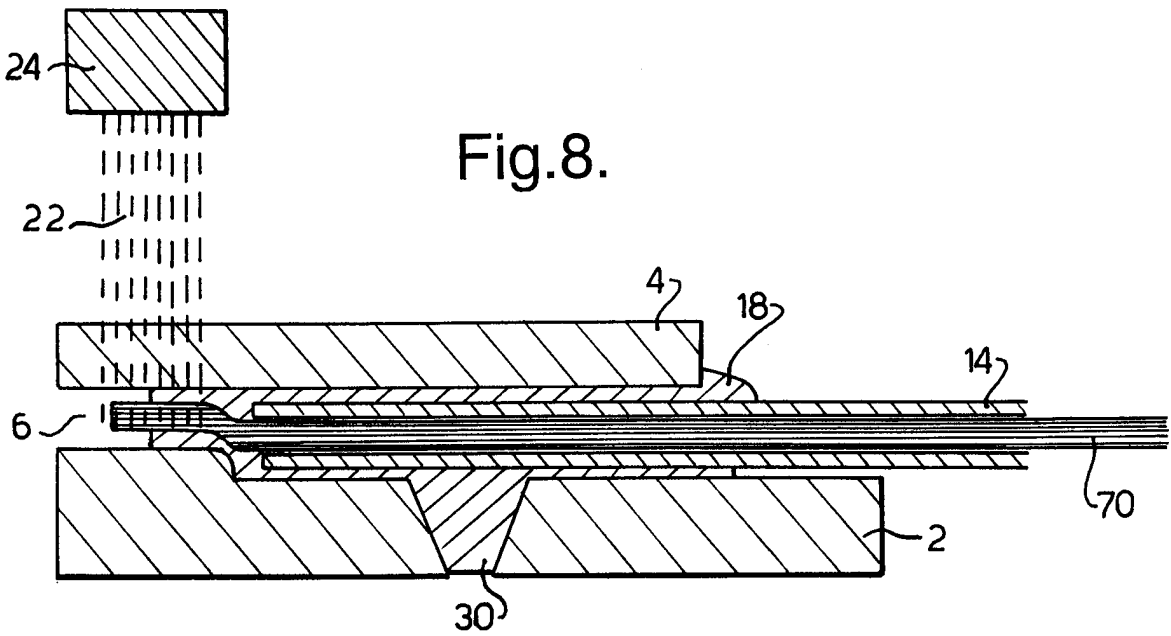
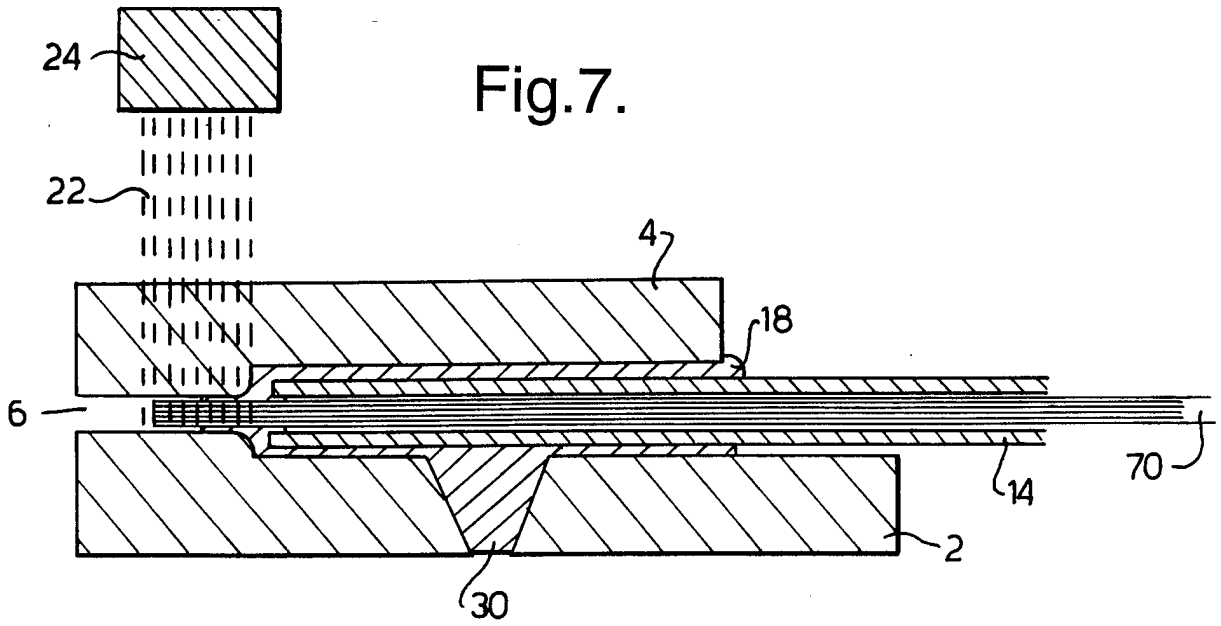

Fig.10.

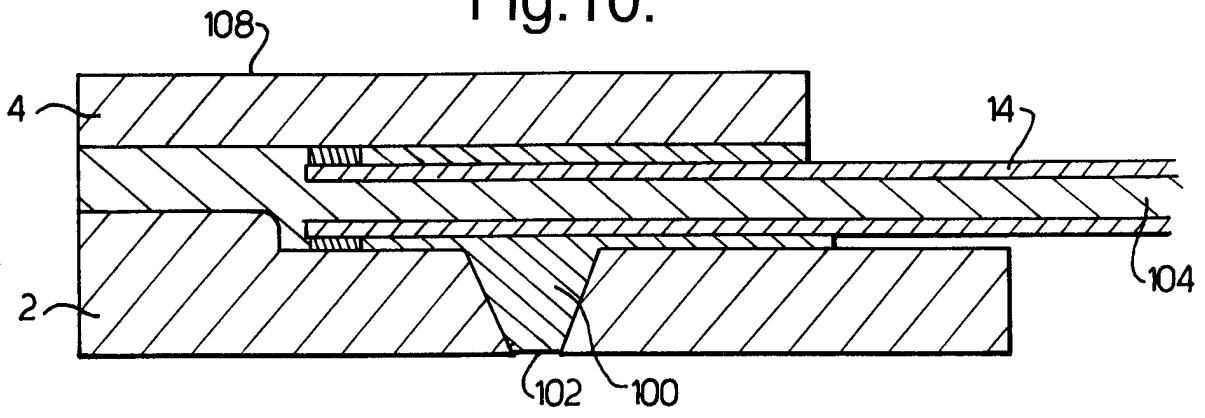

Fig.11.

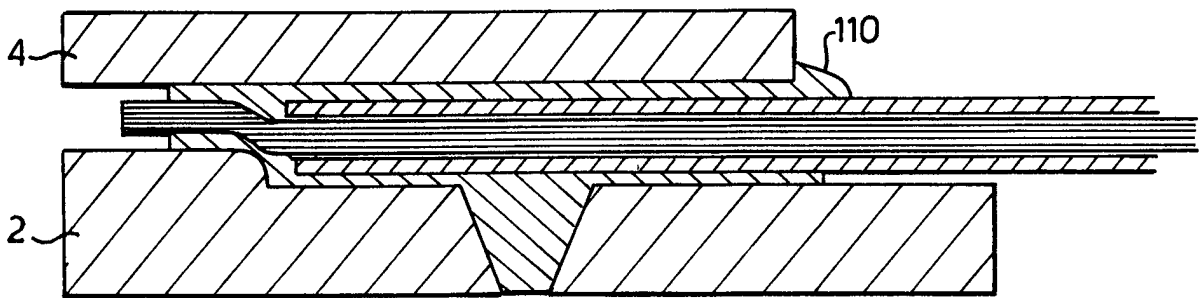

Fig.12.

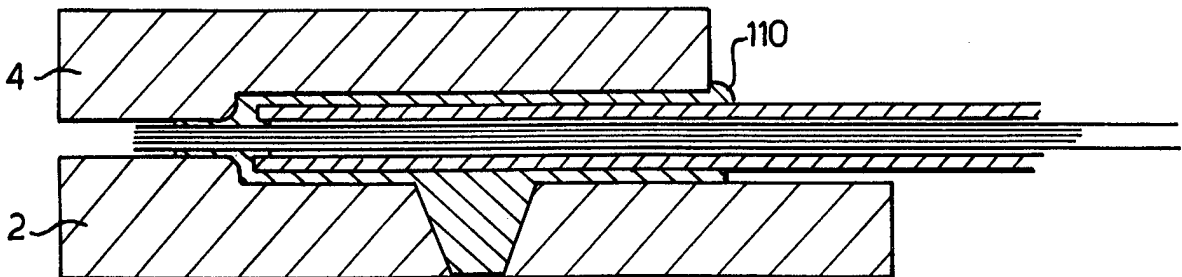

Fig.13a.

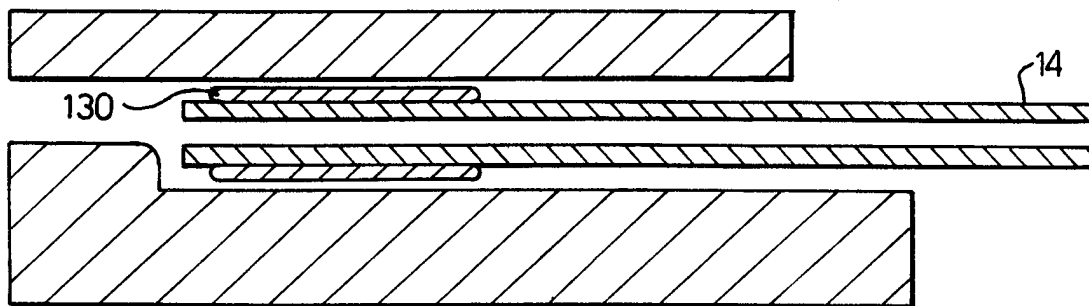

Fig.13b.

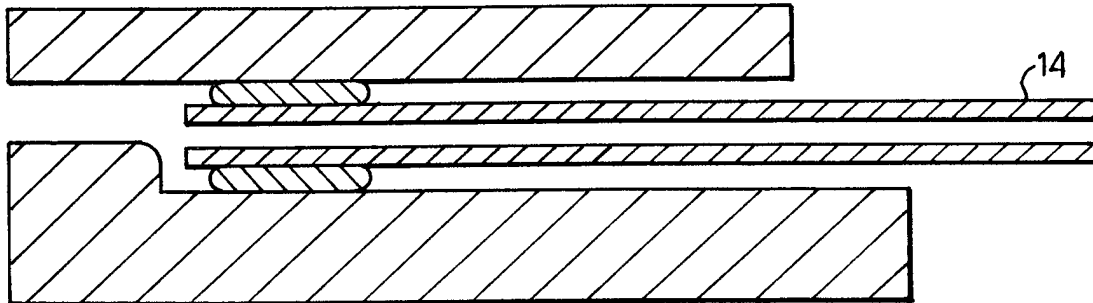
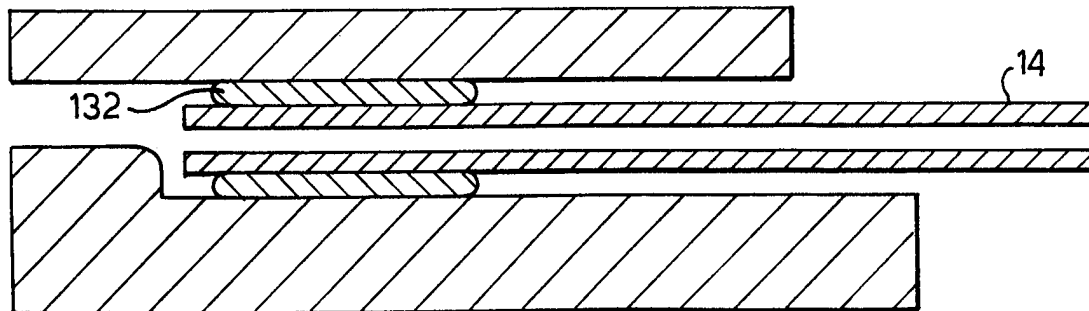

Fig.13c.



INTERNATIONAL SEARCH REPORT

International Application No

PCT/GB 97/03363

A. CLASSIFICATION OF SUBJECT MATTER
 IPC 6 F16L13/11 F15C5/00

According to International Patent Classification (IPC) or to both national classification and IPC

B. FIELDS SEARCHED

Minimum documentation searched (classification system followed by classification symbols)

IPC 6 F16L F15C B01L G01F G01N

Documentation searched other than minimum documentation to the extent that such documents are included in the fields searched

Electronic data base consulted during the international search (name of data base and, where practical, search terms used)

C. DOCUMENTS CONSIDERED TO BE RELEVANT

Category °	Citation of document, with indication, where appropriate, of the relevant passages	Relevant to claim No.
P,A	US 5 611 846 A (OVERTON EDWARD B ET AL) 18 March 1997 see column 10, line 1 - line 19; figure 3 ---	1,15
P,A	EP 0 789 238 A (CHROMPACK INT BV) 13 August 1997 see column 3, line 36 - line 43; figures 1-3 ---	1,15
A	US 4 969 938 A (AMERICA WILLIAM G) 13 November 1990 see column 2, line 40 - column 2, line 57; figure ---	1,15
A	EP 0 319 175 A (EMI PLC THORN) 7 June 1989 cited in the application see claim 1 ---	1,15
	-/--	

Further documents are listed in the continuation of box C.

Patent family members are listed in annex.

° Special categories of cited documents :

- "A" document defining the general state of the art which is not considered to be of particular relevance
- "E" earlier document but published on or after the international filing date
- "L" document which may throw doubts on priority claim(s) or which is cited to establish the publication date of another citation or other special reason (as specified)
- "O" document referring to an oral disclosure, use, exhibition or other means
- "P" document published prior to the international filing date but later than the priority date claimed

- "T" later document published after the international filing date or priority date and not in conflict with the application but cited to understand the principle or theory underlying the invention
- "X" document of particular relevance; the claimed invention cannot be considered novel or cannot be considered to involve an inventive step when the document is taken alone
- "Y" document of particular relevance; the claimed invention cannot be considered to involve an inventive step when the document is combined with one or more other such documents, such combination being obvious to a person skilled in the art.
- "&" document member of the same patent family

Date of the actual completion of the international search

8 April 1998

Date of mailing of the international search report

17/04/1998

Name and mailing address of the ISA

European Patent Office, P.B. 5818 Patentlaan 2
 NL - 2280 HV Rijswijk
 Tel. (+31-70) 340-2040, Tx. 31 651 epo nl,
 Fax: (+31-70) 340-3016

Authorized officer

Ernst, R

INTERNATIONAL SEARCH REPORT

In: tional Application No

PCT/GB 97/03363

C.(Continuation) DOCUMENTS CONSIDERED TO BE RELEVANT

Category	Citation of document, with indication, where appropriate, of the relevant passages	Relevant to claim No.
A	<p>RESTON R R ET AL: "SILICON-MICROMACHINED GAS CHROMATOGRAPHY SYSTEM USED TO SEPARATE AND DETECT AMMONIA AND NITROGEN DIOXIDE PART I: DESIGN, FABRICATION, AND INTEGRATION OF THE GAS CHROMATOGRAPHY SYSTEM"</p> <p>JOURNAL OF MICROELECTROMECHANICAL SYSTEMS, vol. 3, no. 4, 1 December 1994, pages 134-146, XP000495169 cited in the application see page 139</p> <p style="text-align: center;">-----</p>	1, 15

INTERNATIONAL SEARCH REPORT

Information on patent family members

International Application No

PCT/GB 97/03363

Patent document cited in search report	A	Publication date	Patent family member(s)	Publication date
US 5611846	A	18-03-1997	NONE	
EP 0789238	A	13-08-1997	NONE	
US 4969938	A	13-11-1990	NONE	
EP 0319175	A	07-06-1989	DE 3886507 D	03-02-1994
			DE 3886507 T	09-06-1994
			JP 2001949 A	08-01-1990
			JP 2703000 B	26-01-1998
			US 5219712 A	15-06-1993