

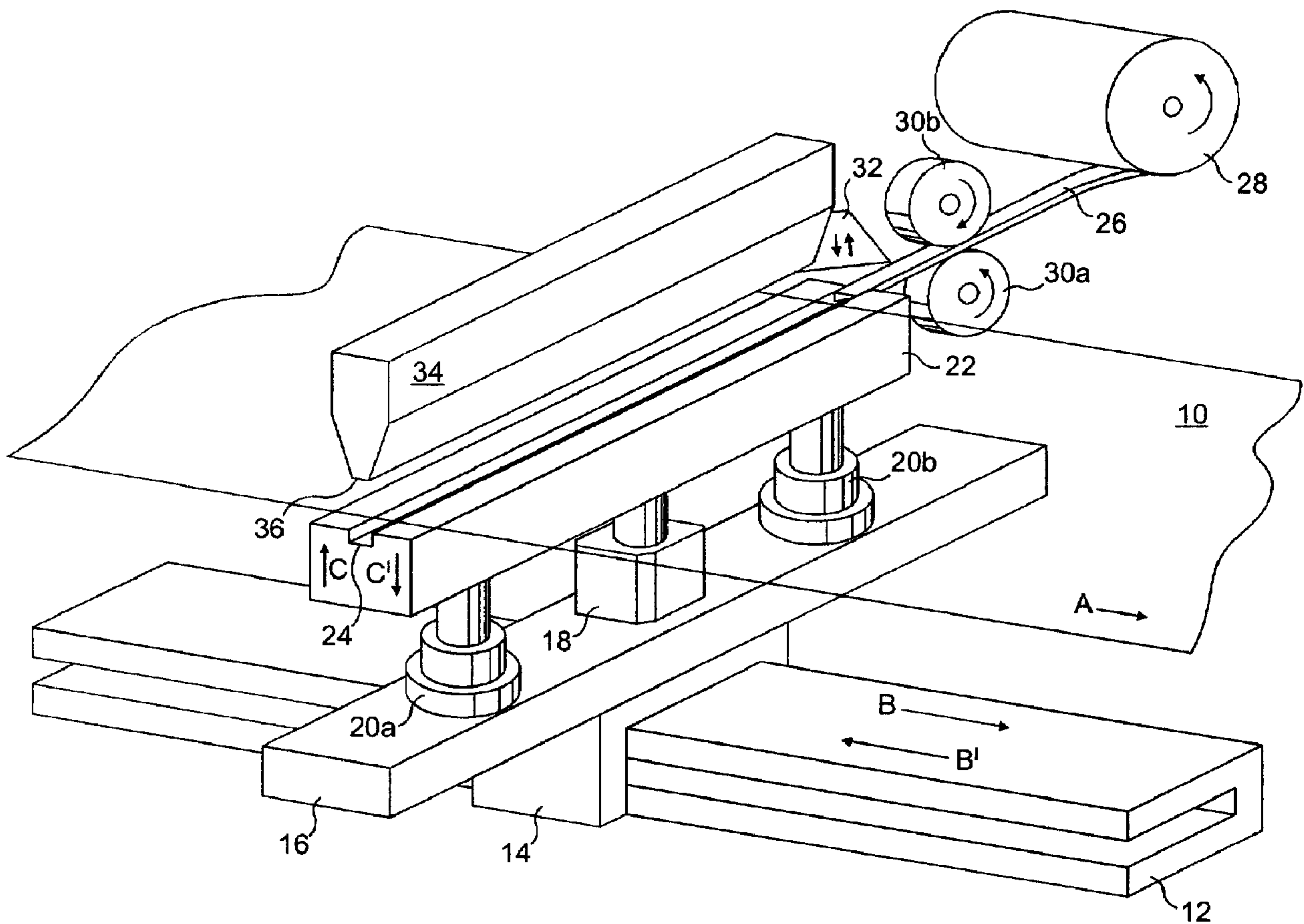

(86) Date de dépôt PCT/PCT Filing Date: 2005/01/21  
 (87) Date publication PCT/PCT Publication Date: 2005/08/04  
 (45) Date de délivrance/Issue Date: 2010/05/11  
 (85) Entrée phase nationale/National Entry: 2006/07/20  
 (86) N° demande PCT/PCT Application No.: GB 2005/000216  
 (87) N° publication PCT/PCT Publication No.: 2005/070661  
 (30) Priorité/Priority: 2004/01/23 (GB0401500.4)

(51) Cl.Int./Int.Cl. *B31B 19/90* (2006.01),  
*B31B 1/90* (2006.01)  
 (72) Inventeur/Inventor:  
LEIGHTON, MURRAY EDWARD BRUCE, GB  
 (73) Propriétaire/Owner:  
ILLINOIS TOOL WORKS INC., US  
 (74) Agent: FINLAYSON & SINGLEHURST

(54) Titre : APPLICATION DE FERMETURES A GLISSIERE SUR UN MATERIAU EN FILM EN MOUVEMENT  
 (54) Title: APPLICATION OF ZIPPERS TO A MOVING FILM MATERIAL



(57) Abrégé/Abstract:

An apparatus for application of zippers to film material (10) comprises an applicator bar (22) for presenting pre-cut lengths of zipper (25) to the film and a heated sealing bar (34) for sealing the pre-cut lengths to the film. The applicator bar, the sealing bar, feed

(57) **Abrégé(suite)/Abstract(continued):**

rollers (30a, 30b) and a zipper cutter (32) are mounted for movement with the film on a linear motor (14). A pneumatic cylinder (18) raised the application bar towards the film (10). The applicator bar moves .in direction C to apply the zipper to the film (10) moving in direction A, then moves with the sealing bar and the film in direction B, away from the film in direction C', back to its starting position in direction B', then towards the film again in direction C. A further length of zipper may be fed to the applicator bar at any time after the bar has moved away from the film in direction C' and therefore during an end portion of the forward stroke of the motor, or during its return stroke.

(12) INTERNATIONAL APPLICATION PUBLISHED UNDER THE PATENT COOPERATION TREATY (PCT)

(19) World Intellectual Property  
Organization  
International Bureau



(43) International Publication Date  
4 August 2005 (04.08.2005)

PCT

(10) International Publication Number  
**WO 2005/070661 A1**

(51) International Patent Classification<sup>7</sup>: **B31B 19/90**, 1/90

(21) International Application Number:

PCT/GB2005/000216

(22) International Filing Date: 21 January 2005 (21.01.2005)

(25) Filing Language: English

(26) Publication Language: English

(30) Priority Data:

0401500.4 23 January 2004 (23.01.2004) GB

(71) Applicant (for all designated States except US):  
**SUPREME PLASTICS HOLDINGS LIMITED**  
[GB/GB]; Supreme House, 300 Regents Park Road,  
Finchley, London N3 2TL (GB).

(72) Inventor; and

(75) Inventor/Applicant (for US only): **LEIGHTON, Murray, Edward, Bruce** [GB/GB]; 19 Victoria Avenue, Whitley Bay, Tyne and Wear NE26 2BA (GB).

(74) Agent: **ACKROYD, Robert**; W.P. Thompson & Co., Eastcheap House, Central Approach, Letchworth Garden City, Hertfordshire SG6 3DS (GB).

(81) Designated States (unless otherwise indicated, for every kind of national protection available): AE, AG, AL, AM, AT, AU, AZ, BA, BB, BG, BR, BW, BY, BZ, CA, CH, CN, CO, CR, CU, CZ, DE, DK, DM, DZ, EC, EE, EG, ES, FI, GB, GD, GE, GH, GM, HR, HU, ID, IL, IN, IS, JP, KE, KG, KP, KR, KZ, LC, LK, LR, LS, LT, LU, LV, MA, MD, MG, MK, MN, MW, MX, MZ, NA, NI, NO, NZ, OM, PG, PH, PL, PT, RO, RU, SC, SD, SE, SG, SK, SL, SY, TJ, TM, TN, TR, TT, TZ, UA, UG, US, UZ, VC, VN, YU, ZA, ZM, ZW.

(84) Designated States (unless otherwise indicated, for every kind of regional protection available): ARIPO (BW, GH, GM, KE, LS, MW, MZ, NA, SD, SL, SZ, TZ, UG, ZM, ZW), Eurasian (AM, AZ, BY, KG, KZ, MD, RU, TJ, TM), European (AT, BE, BG, CH, CY, CZ, DE, DK, EE, ES, FI, FR, GB, GR, HU, IE, IS, IT, LT, LU, MC, NL, PL, PT, RO, SE, SI, SK, TR), OAPI (BF, BJ, CF, CG, CI, CM, GA, GN, GQ, GW, ML, MR, NE, SN, TD, TG).

Published:

— with international search report

[Continued on next page]

(54) Title: APPLICATION OF ZIPPERS TO A MOVING FILM MATERIAL

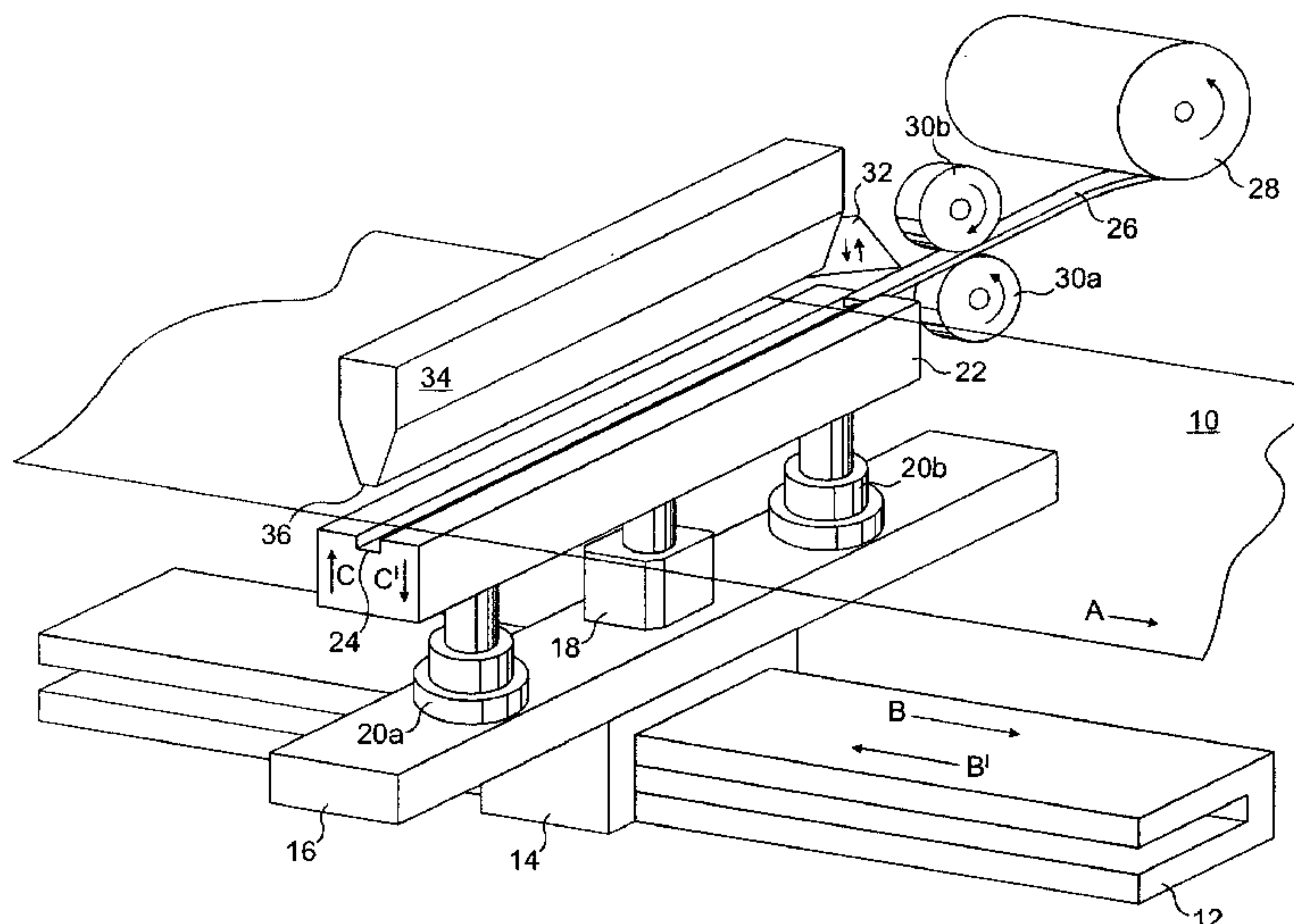

(57) Abstract: An apparatus for application of zippers to film material (10) comprises an applicator bar (22) for presenting pre-cut lengths of zipper (25) to the film and a heated sealing bar (34) for sealing the pre-cut lengths to the film. The applicator bar, the sealing bar, feed rollers (30a, 30b) and a zipper cutter (32) are mounted for movement with the film on a linear motor (14). A pneumatic cylinder (18) raised the application bar towards the film (10). The applicator bar moves in direction C to apply the zipper to the film (10) moving in direction A, then moves with the sealing bar and the film in direction B, away from the film in direction C', back to its starting position in direction B', then towards the film again in direction C. A further length of zipper may be fed to the applicator bar at any time after the bar has moved away from the film in direction C' and therefore during an end portion of the forward stroke of the motor, or during its return stroke.

WO 2005/070661 A1

**WO 2005/070661 A1**



---

*For two-letter codes and other abbreviations, refer to the "Guidance Notes on Codes and Abbreviations" appearing at the beginning of each regular issue of the PCT Gazette.*



## APPLICATION OF ZIPPERS TO A MOVING FILM MATERIAL

This invention relates to methods of and apparatus for  
5 applying reclosable fastener profiles, otherwise known as  
zippers, to film material, where the zipper is applied  
transversely to the direction of movement of the film  
material.

Transverse web or cross-web technology is now well known,  
10 where a zipper is applied transversely to the longitudinal  
axis of a film, but by its very nature the inclusion of means  
to stop the film and apply the zipper makes a continuously  
operating unit inefficient.

It is therefore an object of the present invention to  
15 provide a method of and apparatus for applying the zipper  
while the film material or web is still moving at the normal  
line rate, thus maintaining the efficiency of the line  
operation.

Our international patent application WO-A-03/097341  
20 describes and claims such an apparatus and method. The  
object of the present application is to provide further such  
apparatus and method.

WO-A-99/59872 (Robert Bosch GmbH) discloses an apparatus  
for applying zippers transversely to a moving web of film  
25 material. The apparatus includes a fixed guide cassette to  
which lengths of zipper are fed for application to the web by  
a securing device which includes a pair of sealing jaws which  
are movable back and forth in the direction of web movement.

According to the present invention there is provided an  
30 apparatus for applying a zipper strip to a moving film  
transversely to the direction of movement of the film,  
comprising means for producing continuous movement of the film  
in the said direction, applicator means arranged to receive  
the zipper strip, to present it to the film at a first  
35 location and to move with the film in the said direction to

a second location, and sealing means arranged to move together with the applicator means in the said direction from the first to the second location to effect sealing of the zipper strip to the film during the said movement, the applicator means and  
5 the sealing means being arranged for reciprocal return movement in a direction opposite to the said direction from the second location to the first location.

Preferably, the apparatus includes a zipper-supply means arranged to supply lengths of zipper strip to the applicator  
10 means, the applicator means, the zipper-supply means and the sealing means being arranged for movement as a unit between the first and second locations.

Advantageously, the zipper-supply means comprises means for cutting continuous zipper into lengths for application to  
15 the film and means for feeding the continuous zipper to the cutting means.

Conveniently, the apparatus includes means for receiving a continuous zipper supply, the supply-receiving means being stationary relative to the zipper-supply means.

20 Preferably, the applicator means and the sealing means are located at respective opposite sides of the film.

Conveniently, the sealing means comprises a heated sealing bar.

Advantageously, the applicator means and the sealing  
25 means are reciprocally driven by a linear motor.

Preferably, the applicator means is movable towards and away from the film in a direction substantially perpendicular to the said direction.

The invention also provides a method of applying a zipper  
30 strip to a moving film transversely to the direction of movement of the film, the method comprising moving the film continuously in said direction, supplying a zipper strip to the film at a first location by an applicator means, moving the applicator means and sealing means together with each  
35 other in the said direction from the first to the second



location to effect sealing of the zipper strip to the film during the movement from the first to the second location, and returning the applicator means and sealing means in a direction opposite to the said direction from the second to  
5 the first location.

Preferably, the lengths of zipper strip are supplied to the applicator means from a zipper-supply means, the zipper-supply means being moved as a unit with the applicator means and the sealing means between the first and second locations.

10 A further zipper strip length may be supplied from the zipper-supply means to the applicator means no later than the return of the applicator means, zipper-supply means and sealing means to the first location.

Advantageously, further zipper strip length is supplied  
15 to the applicator means after sealing of the first zipper strip length to the film but prior to arrival of the applicator means, zipper-supply means and sealing means at the second location.

Preferably, the further zipper strip length is supplied  
20 to the applicator means during the return movement of the applicator means, zipper-supply means and sealing means to the first location.

Preferably, the applicator means is moved at the first location in a direction substantially perpendicular to the  
25 said direction of movement of the film, in order to apply the zipper to the film and is moved in the opposite direction after sealing of the zipper strip to the film and prior to its return movement to the first location.

An embodiment of the invention will now be described by  
30 way of example with reference to the drawings of this specification, in which:

Figure 1 is a somewhat schematic perspective view of an apparatus for applying zipper strips transversely to a moving web;

35 Figure 2 is a somewhat schematic perspective view of a

horizontally-operating form-fill-seal packaging machine incorporating the apparatus of figure 1;

Figure 3 is a schematic side view showing the operation of the apparatus of figure 1;

5 Figure 4 is a somewhat schematic top plan view of the apparatus of figure 1 in operation; and

Figures 5a to 5e are further schematic side views showing the operation of the apparatus of figure 1.

Figure 1 shows a web of plastics film 10 which is moving  
10 continuously in the direction A shown by an arrow. A guideway 12 for a linear motor 14 is mounted beneath the film 10. The linear motor can be driven to move linearly in first and second, opposite directions B,B' shown by arrows. The linear motor 14 may be of any of the many known types of  
15 linear motor which are well-known to one skilled in the art of the present invention. The linear motor 14 is provided with suitable power and control means which are also well-known to one skilled in the art and are therefore not shown in figure 1 or described further herein.

20 A support platform 16 is mounted on the motor 14 and carries centrally a pneumatic cylinder 18, to which compressed air can be supplied by suitable pressure and control means which are well-known in the art and are, again not shown in figure 1 or described further herein. To each side of the  
25 cylinder 18, the platform carries a guide 20a, 20b, each of which consists of a piston-and-cylinder arrangement.

The cylinder 18 and guides 20a, 20b carry at their upper ends a zipper applicator bar 22. The applicator bar 22 is movable below the film 10 in first and second, opposite  
30 directions C,C' shown by arrows, the directions being perpendicular to the direction A of movement of the film 10. The applicator bar 22 has a longitudinal groove 24 which is shaped and dimensioned to receive lengths of zipper 26 which is fed continuously from a spool 28 which is mounted at a  
35 suitable stationary location nearby. The continuous length



of zipper 26 passes through the nip of a pair of counter-rotating drive rollers 30a, 30b which are mounted on support platform 16. The drive rollers 30a, 30b are driven by a suitable drive means (not shown) and feed the zipper 26 5 beneath a reciprocating blade 32 which is mounted on the applicator bar 22 and is driven and controlled by means (not shown) to cut the zipper 26 into predetermined lengths, usually less than the width of the film 10, the continuous length of zipper 26 being fed into the slot 24 in the 10 applicator bar 22 by the drive rollers 30a, 30b prior to cutting by the blade 32. The zipper 26 consists of continuous lengths of interengaging releasable male and female fastener strips, for example of any of many known types.

A heated sealing bar 34 is positioned above the film 10 15 and is fixed relative to the platform 16. The sealing bar 34 is shaped along its lower edge 36 to align with the upper edge of the applicator bar 22 adjacent to the groove 24 in the applicator bar and thereby to apply heat to the film 10 at a location adjacent the location of a length of zipper 26 20 located in the groove 24 of the applicator bar 22 and presented to the film 10 by upward movement of the applicator bar 22.

Figure 2 of the drawings shows the general arrangement of a horizontally-operating form-fill-seal packaging machine 25 which includes the apparatus of figure 1 which is indicated by the reference numeral 30. The apparatus 50 is orientated with the applicator bar 22 uppermost in figure 2: any orientation is possible. In the orientation of figure 2, a suitable vacuum device (not shown) is included to retain 30 zipper lengths in the groove 24.

It should be noted that, although the invention is described herein with reference to a horizontally-operating form-fill-seal machine, the invention is equally applicable to vertically-operating form-fill-seal machines (as are also 35 well-known in the packaging art), to machines of the kind

known as bag-converting machines which produce empty reclosable bags, and to machines (known as reel-to-reel machines) which apply lengths of zipper to a continuous film for subsequent use in form-fill-seal **or** bag-converting machines.

Returning now to figure 2, the film 10 is stored in a roll 52 which can rotate to allow the film to be drawn by a pair of feed rollers 54a, 54b through the apparatus **30**, whence it passes around further guide rollers 56a, 56b before being fed to a forming box 58 of a conventional horizontal form-fill-seal packaging machine. Articles 60 to be packaged are fed in the direction E shown by an arrow on a conveyor belt 62 to the forming box 58, where, in the conventional manner, the film 10 is folded around the article 60 and the longitudinal edges of the film 10 are brought together and sealed to each other to form a back seal. Subsequently to this, and at a location downstream of the forming box 58, the folded film passes between a pair of heated cross-seal jaws 64a, 64b which form transverse seals between the inner faces of the folded film and also sever the film to provide individual sealed packages 64 containing the articles 60.

It should be mentioned that, in accordance with cross-web technology, the zipper 26 is cut into lengths which are slightly less than one-half of the width of the film 10, the male and female profiles of the zipper lengths being engaged with each other. The lengths of zipper are located by the applicator bar 22 centrally of the film 12. Thus, when the film is folded in the forming box 58, the portions of the film to each side of the zipper length form the sides and one face of the eventual package. The length of zipper is attached to what becomes the other face of the package, so that, by the operation of the cross-seal jaws, heat is applied to the first face of the package to seal the zipper strip to that face and, after that, the film is severed into individual packages. The packages thus have a transverse heat seal at each end and,



positioned inwardly of one of the seals, an openable and reclosable seal formed by the zipper strips for use after opening of the package by breaking the adjacent heat seal.

Figure 3 of the drawings shows the operation of apparatus 5 of figure 1. In figure 3, the film 10 is shown moving in the direction A. The applicator bar 22 is shown movable between its first and second limit positions X, Y, determined by the linear motor 12. Movement from X to Y is referred to herein on the "forward stroke"; movement in the reverse direction is 10 referred to on the "return stroke".

The lengths of zipper 26 are presented to the applicator bar 22 when it is in its first limit position X. The bar is then raised by the pneumatic cylinder 18 in the direction C until it contacts the lower surface of the film 12. Further 15 movement in the direction C results in movement of the film 10 against the sealing bar to apply sealing heat to the opposite face of the film 10, the lower edge of the sealing bar coming to rest on the upper (as shown in figure 1) edge of the applicator bar 22 adjacent the groove 24.

20 The applicator bar 22 and seal bar 32 are then moved in the direction B by the linear motor, until the second limit position Y is reached. During this movement, the speed of travel of the motor 14 and of the film 10 are equal to each other. At the second limit position Y, the applicator bar 22 25 is moved away from the film 10 in the direction C', leaving the zipper length 26 attached to the film 10, prior to its being returned to the first limit position X by movement in the direction B' by the linear motor 14. The cycle is then repeated to apply the zipper strips at spaced intervals along 30 the length of the film 10. The motor 14 is capable of producing a very rapid acceleration and deceleration of the applicator bar 22 and the sealing bar 34, these taking place during the time taken for the movements in the directions C and C'.

35 Figure 4 of the drawings is a schematic plan view



corresponding to figure 3 and showing the assembly of the support platform 16, applicator bar 22, sealing bar 24, blade 32 and drive rollers 30a, 30b (all referred to collectively hereinafter as "the applicator unit") moving between the limit 5 positions X and Y. It will be noted that, during this movement, the spool 28 containing the supply of zipper remains stationary whilst the zipper 26 feeding from the spool 28 can swing in an arc with the movement of the linear motor 14.

Although the applicator unit is depicted twice in 10 figure 4, it will be appreciated that what is shown is the same unit in two different positions in its cycle of movement, the applicator being shown in dashed lines at position Y.

Figures 5a to 5e of the drawings show the operation of the apparatus of figure 4 in more detail. In these figures 15 the film 10 is again shown moving continuously in the direction A. The applicator bar 22 is shown movable between its first and second limit positions X, Y, determined by the linear motor 12.

Figure 5a shows an arbitrary starting point in the cycle 20 in which the applicator bar 22 and the sealing bar 34 are at the first limit position X and with a length of zipper 26 received in the groove in the applicator bar. From this position, the applicator bar 22 is raised by the pneumatic cylinder 18 in the direction C until it contacts the lower 25 surface of the film 12. Further movement in the direction C results in movement of the film 10 against the sealing bar 34 to apply sealing heat and pressure to the opposite face of the film 12, the lower edge 36 of the sealing bar coming to rest on the upper edge of the applicator bar 22 adjacent the 30 groove 24. The condition shown in figure 5b of the drawings is thereby achieved. The application of heat from the sealing bar 34 to the applicator bar 22 adjacent the groove 24 causes fusion of the zipper strip to the film 10.

In the next phase of the cycle of operation, the 35 applicator unit is moved towards the second limit position Y

by the linear motor in the direction B, the motor moving at the same linear speed as the film 10. At a predetermined point in this forward stroke of the application unit, determined to be after the point at which the zipper strip 26 has become attached to the film 10, the pneumatic cylinder 18 is actuated to lower the applicator bar 22 to leave the zipper length 26 adhered to the lower surface of the film 10. The groove in the applicator bar is now empty and ready to receive a further length of zipper supplied by the rollers 30a, 30b. This condition is shown in figure 5c. The condition may be reached at any point in the forward stroke of movement of the applicator unit from the first to the second limit position, up to the second limit position itself.

In the next phase of the cycle of operation, a further length of zipper 26 is fed by the drive rollers 30a, 30b into the groove 24 in the applicator bar 22 and cut to length by the blade 32. This may take place before the applicator unit has reached the second limit position, at the second limit position, or at a later stage in the cycle of operation (see below). The condition achieved when the zipper length has been fed into the groove 24 not later than the second limit position is shown in figure 5d of the drawings.

At the second limit position Y, the applicator unit is brought to a halt by the linear motor 14. At this point in the operational cycle, a further length of zipper 26' may or may not have been fed into the applicator bar groove 24.

The linear motor is now controlled to return in direction B' from the second to the first limit position. If it has not already been done, a further length of zipper 26' is fed into the groove 24 during this return stroke of movement of the applicator unit. Figure 5e shows the situation at an intermediate point on the reverse stroke after feeding of the further zipper length into the applicator bar slot. At the end of the reverse stroke, the condition shown in figure 5a is again achieved. During the reverse stroke,

10

the cylinder 18 maintains the applicator bar 22 in its lowered position; the speed of movement of the unit is conveniently the same as during the forward stroke but this is not necessarily so.

5



**WHAT IS CLAIMED IS:**

1. An apparatus for applying a zipper strip to a moving film transversely to the direction of movement of the film, comprising means for producing continuous movement of the film in the said direction, applicator means arranged to receive the zipper strip, to present it to the film at a first location and to move with the film in the said direction to a second location, and sealing means arranged to move together with the applicator means in the said direction from the first to the second location to effect sealing of the zipper strip to the film during the said movement, the applicator means and the sealing means being arranged for reciprocal return movement in a direction opposite to the said direction from the second location to the first location.
2. An apparatus according to claim 1, including a zipper-supply means arranged to supply lengths of zipper strip to the applicator means, the applicator means, the zipper-supply means and the sealing means being arranged for movement as a unit between the first and second locations.
3. An apparatus according to claim 2, in which the zipper-supply means comprises means for cutting continuous zipper into lengths for application to the film and means for feeding the continuous zipper to the cutting means.
4. An apparatus according to claim 3, including means for receiving a continuous zipper supply, the supply-receiving means being stationary relative to the zipper-supply means.
5. An apparatus according to any one of claims 1 to 4, in which the applicator means and the sealing means are located at respective opposite sides of the film.
6. An apparatus according to any one of claims 1 to 5, in which the sealing means comprises a heated sealing bar.

7. An apparatus according to any one of claims 1 to 6, in which the applicator means and the sealing means are reciprocally driven by a linear motor.
8. An apparatus according to any one of claims 1 to 7, in which the applicator means is movable towards and away from the film in a direction substantially perpendicular to the said direction.
9. A method of applying a zipper strip to a moving film transversely to the direction of movement of the film, the method comprising moving the film continuously in said direction, supplying a zipper strip to the film at a first location by an applicator means, moving the applicator means together with a sealing means in the said direction from the first to a second location, effecting sealing of the zipper strip to the film during the movement from the first to the second location, and returning the applicator means and sealing means in a direction opposite to the said direction from the second to the first location.
10. A method according to claim 9, in which the lengths of zipper strip are supplied to the applicator means from a zipper-supply means, the zipper-supply means being moved as a unit with the applicator means and the sealing means between the first and second locations.
11. A method according to claim 9 or 10, in which a further zipper strip length is supplied to the applicator means after sealing of a first zipper strip length to the film but prior to arrival of the applicator means, the zipper-supply means and the sealing means at the second location.
12. A method according to claim 9 or 10, in which a further zipper strip length is supplied to the applicator means during the return movement of the applicator means, zipper-supply means and sealing means to the first location.

13. A method according to any one of claims 9 to 12, in which the applicator means is moved at the first location in a direction substantially parallel to the plane of the film and substantially perpendicular to the direction of movement thereof in order to apply the zipper to the film and is moved in the opposite direction after sealing of the zipper strip to the film and prior to its return movement to the first location.



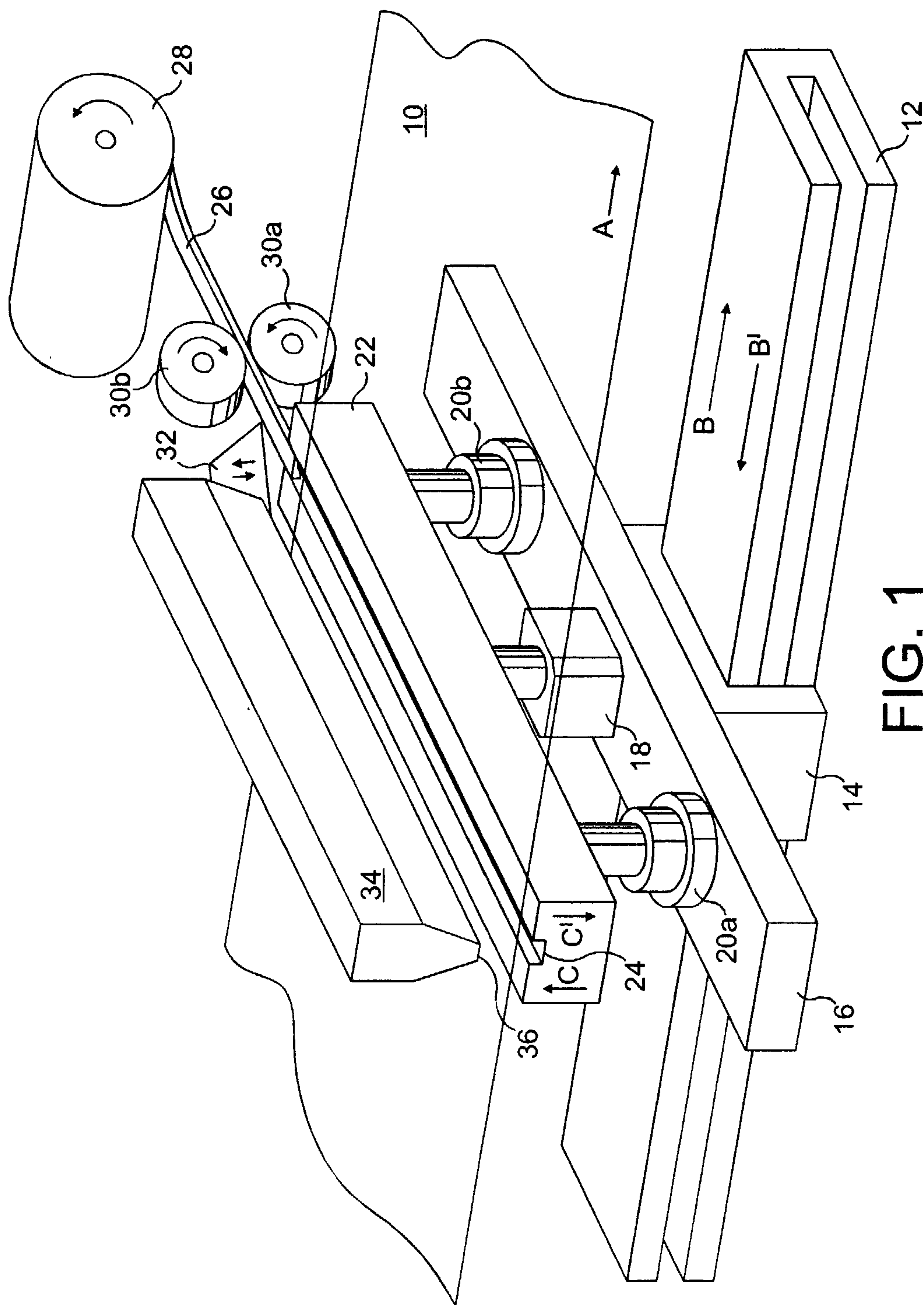

FIG. 1

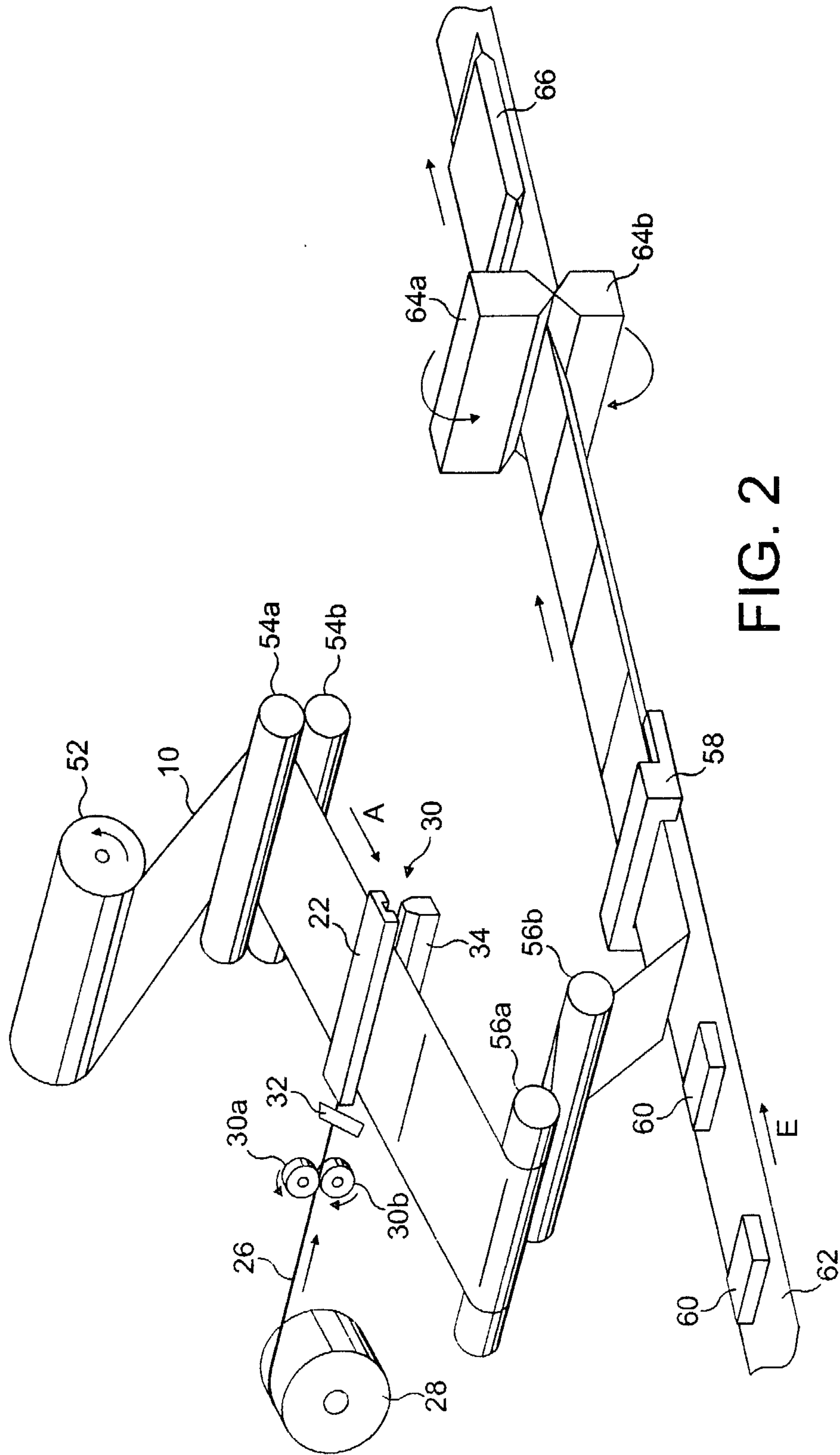

FIG. 2

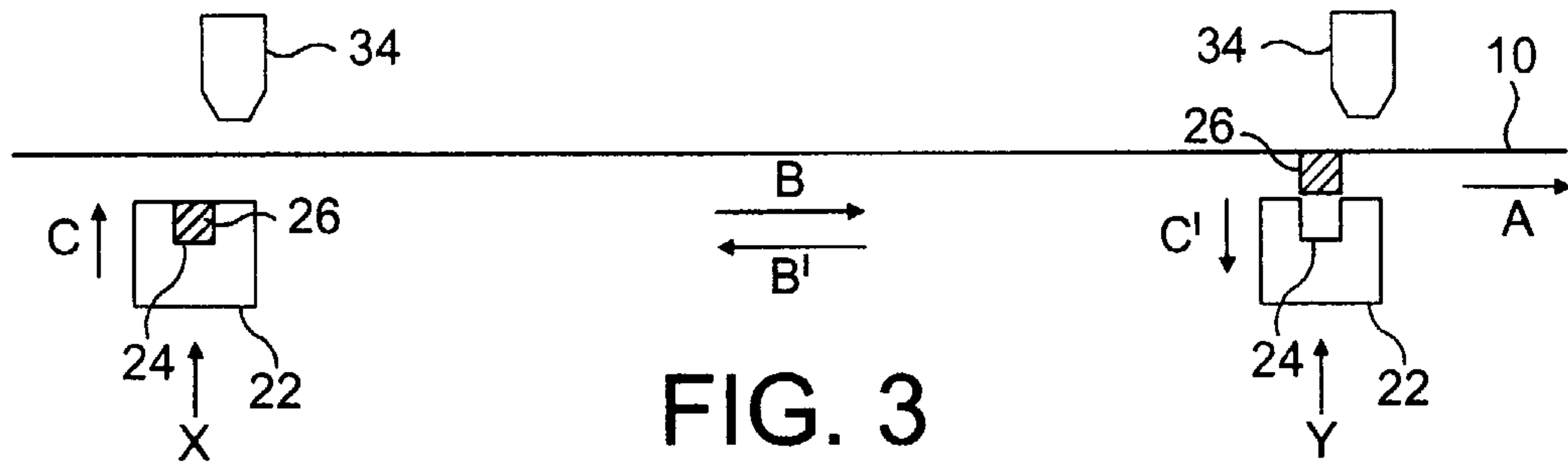

FIG. 3

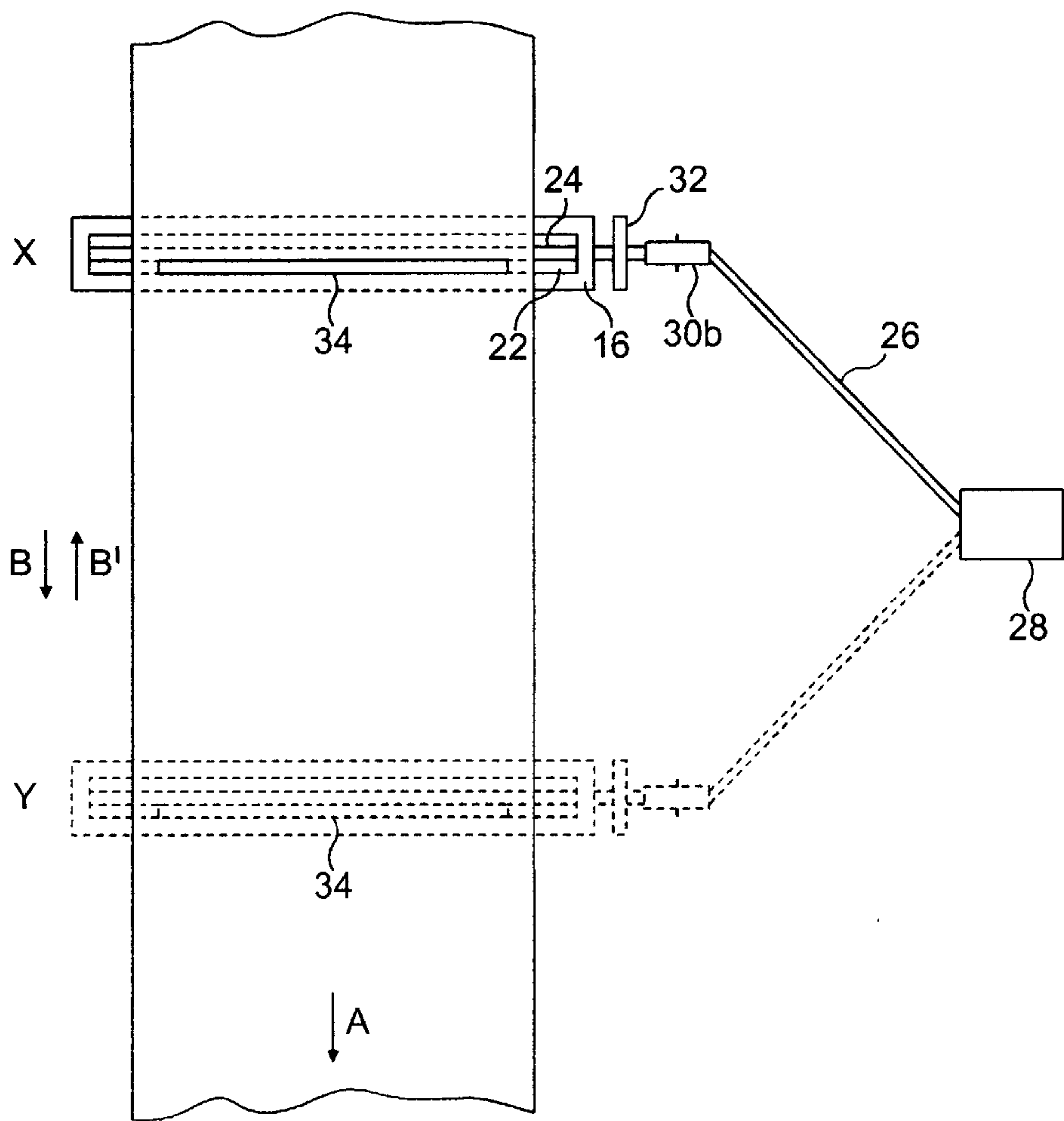

FIG. 4



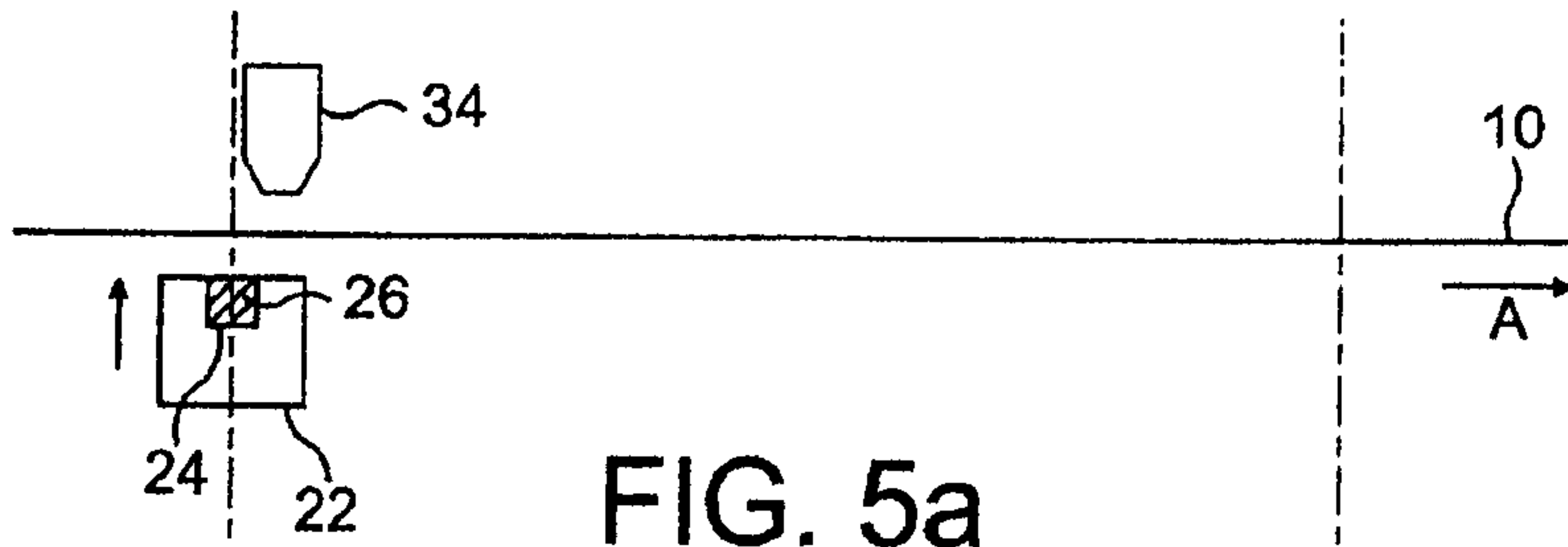

FIG. 5a

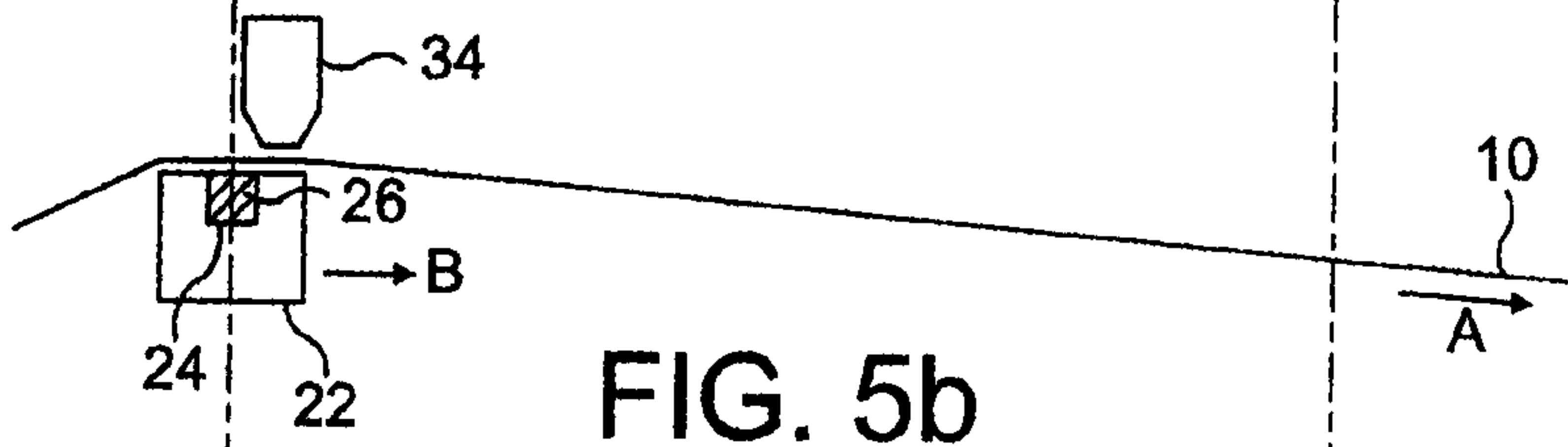

FIG. 5b

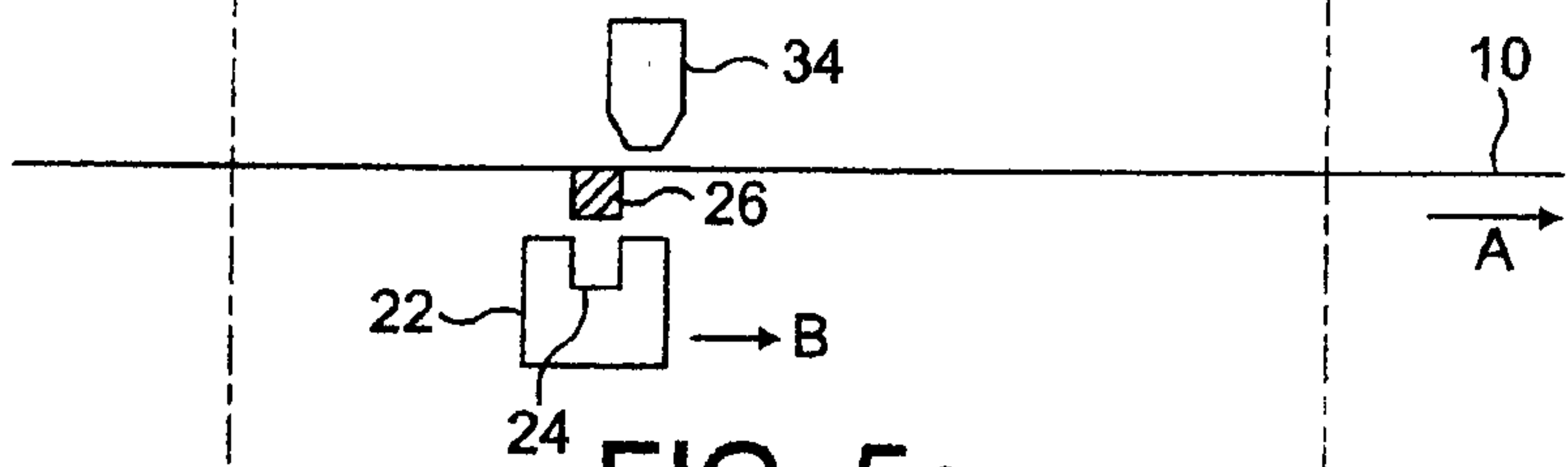

FIG. 5c

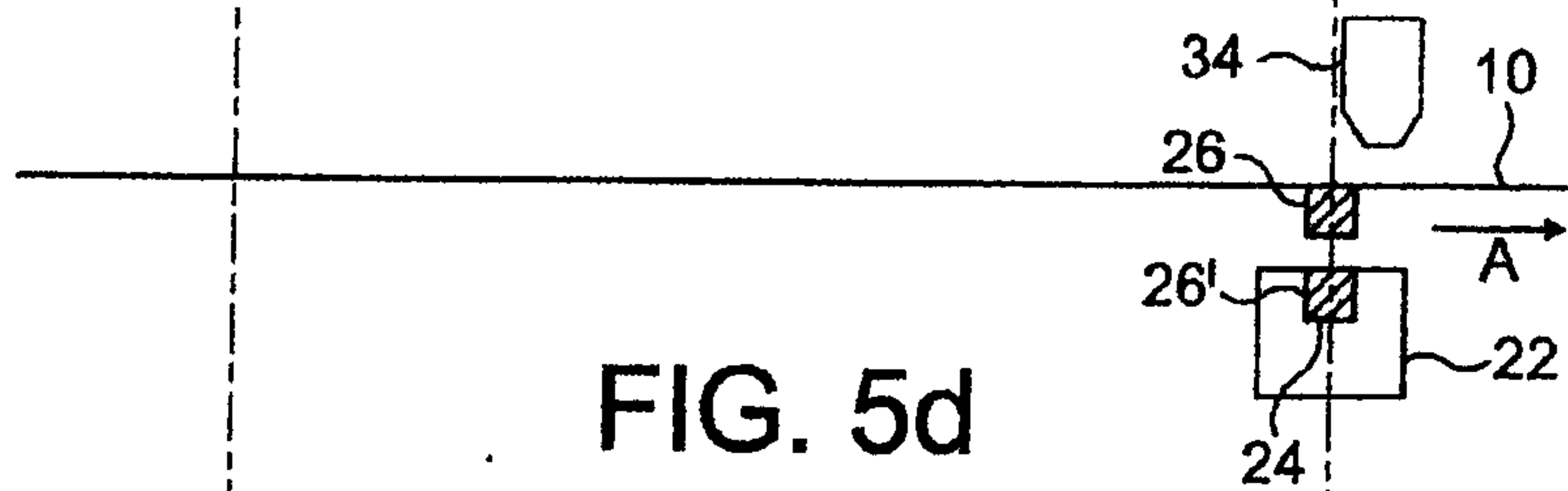

FIG. 5d

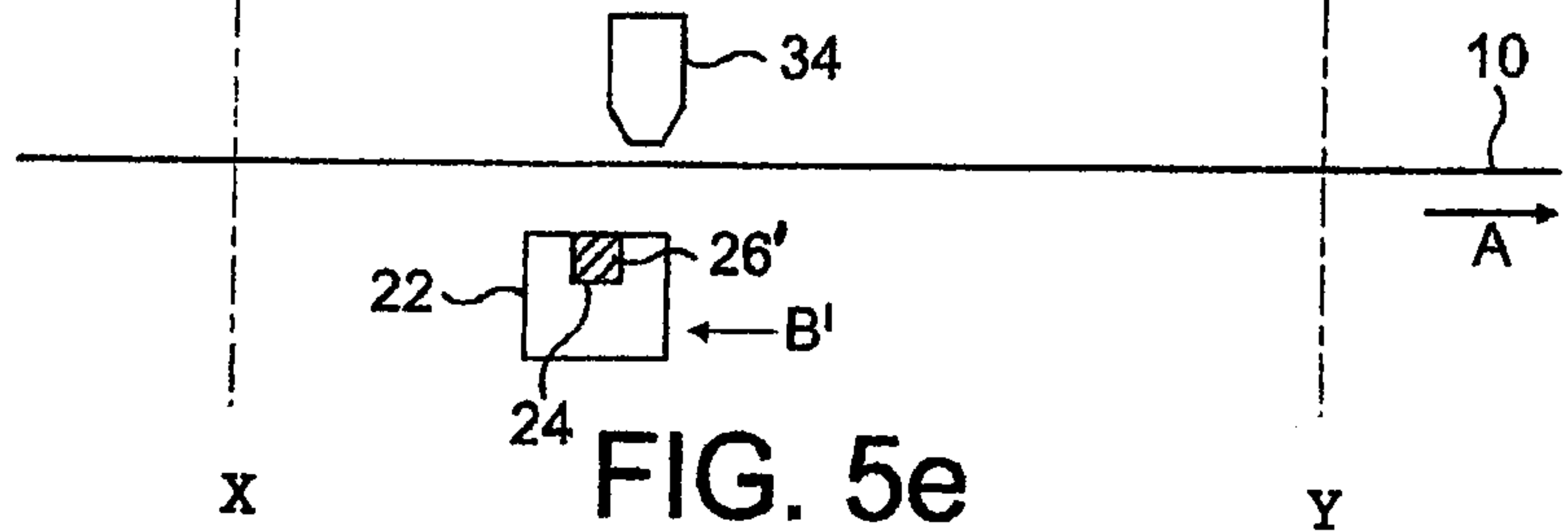

FIG. 5e

*Julay & Singletary*  
PATENT AGENTS

