

(19) World Intellectual Property Organization  
International Bureau



(43) International Publication Date  
17 October 2002 (17.10.2002)

PCT

(10) International Publication Number  
WO 02/081303 A1

- (51) International Patent Classification<sup>7</sup>: **B64C 21/00**, 23/04, 21/10, F15D 1/12
  - (21) International Application Number: PCT/GB02/01444
  - (22) International Filing Date: 26 March 2002 (26.03.2002)
  - (25) Filing Language: English
  - (26) Publication Language: English
  - (30) Priority Data: 0108740.2 6 April 2001 (06.04.2001) GB
  - (71) Applicant (for all designated States except US): **BAE SYSTEMS PLC** [GB/GB]; 6 Carlton Gardens, London SW1Y 5AD (GB).
  - (72) Inventors; and
  - (75) Inventors/Applicants (for US only): **SCOTT, Simon, Joseph** [GB/GB]; Bae Systems (Operations) Ltd, PO Box 5, Bristol BS34 7QW (GB). **JOHNSON, Graham, Andrew** [GB/GB]; Bae Systems (Operations) Ltd, PO Box 5, Bristol BS34 7QW (GB). **THORNTON, Edward** [GB/GB]; 17 Longfurlong Lane, Tetbury, Gloucestershire GL8 8TJ (GB).
  - (74) Agent: **MACKETT, Margaret, Dawn**; Bae Systems plc, Group IP Dept, Lancaster House, P.O. Box 87, Farnborough Aerospace Centre, Farnborough, Hampshire GU14 6YU (GB).
  - (81) Designated States (national): AE, AG, AL, AM, AT, AU, AZ, BA, BB, BG, BR, BY, BZ, CA, CH, CN, CO, CR, CU, CZ, DE, DK, DM, DZ, EC, EE, ES, FI, GB, GD, GE, GH, GM, HR, HU, ID, IL, IN, IS, JP, KE, KG, KP, KR, KZ, LC, LK, LR, LS, LT, LU, LV, MA, MD, MG, MK, MN, MW, MX, MZ, NO, NZ, OM, PH, PL, PT, RO, RU, SD, SE, SG, SI, SK, SL, TJ, TM, TN, TR, TT, TZ, UA, UG, US, UZ, VN, YU, ZA, ZM, ZW.
  - (84) Designated States (regional): ARIPO patent (GH, GM, KE, LS, MW, MZ, SD, SL, SZ, TZ, UG, ZM, ZW), Eurasian patent (AM, AZ, BY, KG, KZ, MD, RU, TJ, TM), European patent (AT, BE, CH, CY, DE, DK, ES, FI, FR, GB, GR, IE, IT, LU, MC, NL, PT, SE, TR), OAPI patent (BF, BJ, CF, CG, CI, CM, GA, GN, GQ, GW, ML, MR, NE, SN, TD, TG).
- Published:**  
— with international search report
- For two-letter codes and other abbreviations, refer to the "Guidance Notes on Codes and Abbreviations" appearing at the beginning of each regular issue of the PCT Gazette.*

(54) Title: TURBULENT FLOW DRAG REDUCTION

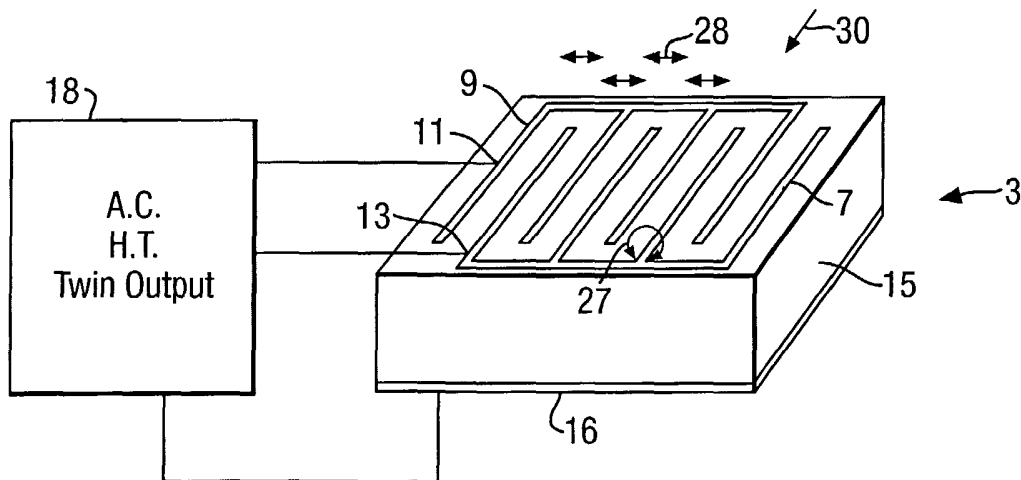

(57) Abstract: The present invention relates to apparatus (3) for influencing fluid flow over a surface (1), and more particularly, but not exclusively, to turbulent boundary layer flow drag reduction for an aircraft. The present invention provides such apparatus including a plasma generator (7) comprising first (7) and second (9) spaced-apart independently controllable electrodes operable to cause a change in direction of the flow of the fluid over the surface.

WO 02/081303 A1

- 1 -

## TURBULENT FLOW DRAG REDUCTION

The present invention relates to apparatus for influencing fluid flow over a surface, and more particularly, but not exclusively, to turbulent boundary layer flow drag reduction for an aircraft.

The boundary layer is a thin layer of fluid (air) that forms, for example, on an aircraft wing during flight adjacent to the surface of the wing in which viscous forces exert an influence on the motion of the fluid and in which the transition between still air and the wing's velocity occurs. Boundary layer control techniques are known where the airflow in the boundary layer is modified to increase and/or decrease drag.

Turbulent boundary layer flow is not yet fully understood, but the recognition that coherent structures exist has allowed efforts to be directed to modifying and/or controlling the turbulent boundary layer flow, as described, for example, in AIAA paper 96-0001 - "Control of Turbulence" - J.Lumley. Direct numerical simulation of the turbulent boundary layer flow, as described, for example in Phys. Fluids A 4 (8) - "Suppression of Turbulence in Wall-bounded Flows by High Frequency Spanwise Oscillations" - W.J.Jung, N.Mangiavacchi, R.Akhavan shows that disrupting the coherent structures could have a dramatic effect on the skin friction, reducing it by up to 40%. If this level could be achieved on an aircraft this would equate to a reduction in total drag of between 10% and 20% offering substantial savings in fuel and/or increases in range. Experimental verification of this numerical prediction has been achieved and published in AIAA paper 97-1795 - "Turbulent Boundary Layer Control by means of Spanwise-wall Oscillation" - K-S.Choi, P.E.Roach, J-R. DeBisschop, and B.R.Clayton. In that paper the use of mechanical oscillation is described to demonstrate skin friction reductions of up to 45%. However, the paper does not suggest how a practical mechanical oscillation system could be implemented successfully.

- 2 -

Other approaches for actively disrupting the coherent structures, such as blowing, or using tiny micro-electro-mechanical actuators have been postulated, but no practical and effective means have been demonstrated. Passive modification of the coherent flow structures has also been attempted, for example, riblets and large eddy break-up devices. These approaches have achieved skin friction drag reductions, but at a much smaller level (less than 10% as opposed to 40%) and are therefore marginal in their overall benefits once extra cost and other penalties (such as increased weight) are considered.

There remains a need for a passive or active system that disrupts the coherent turbulent boundary layer structures to achieve large skin friction reductions, which is both practical and cost effective. In the 1998 conference publication AIAA 36th Aerospace Meeting, paper AIAA 98-0328 - "Boundary Layer Control with a One Atmosphere Uniform Glow Discharge Surface Plasma" - Reece-Roth, Sherman and Wilkinson, an electrode system based on rigid printed circuit board material is described and the interaction of surface plasmas with boundary layers related. The electrode system comprises a single set of a multiplicity of parallel conductive lines all electrically connected to one another. The plasma generating circuit is a high voltage radio frequency source operated at 3.0 kHz. The interaction of the surface plasmas with the airflow was said in this paper to be due to an electrostatic attractive force - termed paraelectric. At the end of the paper it is postulated that this sort of technology might be applicable to the generation of span-wise oscillations for turbulent drag reduction. No information on how this concept could be achieved was given.

Both travelling wave and span-wise oscillation boundary layer disturbances have been tried for drag reduction in sea water (using a combination of magnetic and electric field forces). Travelling waves have been found to be more effective, at least under certain conditions, as described in Science 288, 1230 (2000) - "Suppressing Wall Turbulence by Means of a Transverse Traveling Wave", Du and Karniadakis.

- 3 -

It is an object of the present invention to provide an arrangement for influencing fluid flow so that an object's drag can be reduced.

According to a first aspect of the present invention, there is provided apparatus for influencing fluid flow over a surface, the apparatus including a plasma generator comprising first and second spaced-apart independently controllable electrodes operable to cause a change in direction of the flow of the fluid over the surface. Providing first and second independently controllable electrodes provides far greater flexibility of operation over the prior art system of providing a single set of a multiplicity of parallel conductive lines all electrically connected to one another. For example, the plasma generator may be operable to cause the fluid to flow in alternate generally opposite directions along the surface. In this way, spanwise oscillations may be created. If these generally opposite directions are generally perpendicular to the principal direction of fluid flow over the surface (caused, for example, by movement of the surface through the fluid), this may tend to reduce drag.

Conveniently, the plasma generator may be operable to drive the first and second electrodes alternately. This may cause plasma generation alternately at adjacent electrodes, which may cause oscillation of the fluid flow in the generally opposite directions along the surface.

The first and second electrodes may be in juxtaposed alignment and, optionally, the first and second electrodes may be in substantially parallel alignment. Advantageously, the first and second electrodes may extend generally parallel to the usual direction of motion of the surface in use.

Optionally, the plasma generator includes a dielectric and supports the first and second electrodes on a first side thereof. Electrodes may be formed on surfaces of the dielectric layer or could be within the dielectric layer. Conveniently, the dielectric may be in the form of a flexible sheet so that it may be attached to curved surfaces such as an aircraft wing. Optionally, the dielectric comprises a second side that supports a third electrode of the plasma generator, the first and

- 4 -

second sides being generally opposed. The third electrode may be used as an electrical ground.

In a currently preferred embodiment, each of the first and second electrodes comprise a plurality of electrically connected elongate elements. This is an advantageous arrangement for driving all the elongate members of a single electrode at one time. Advantageously, the first and second electrodes may be arranged such that the elongate elements are interdigitated thereby allowing adjacent elongate members to be of different electrodes.

The third electrode may be planar or it may comprise a plurality of electrically connected elongate elements. With the latter arrangement, it is advantageous for the elongate elements of the first, second and third electrodes to be in a substantially parallel juxtaposed alignment when viewed facing the first side of the dielectric. Preferably, the elongate elements of the first, second and third electrodes extend generally parallel to the usual direction of motion of the surface in use. Optionally, the elongate elements of the third electrodes are laterally offset from the elongate elements of the first and second electrodes.

The present invention also relates to an aircraft aerodynamic surface and an aircraft including apparatus as defined above, wherein the plasma generator is operable to cause a change in direction of the flow of the fluid over the surface.

According to a second aspect of the present invention, there is provided a method of influencing fluid flow over a surface, comprising the step of driving first and second electrodes provided on the surface alternately thereby to generate a plasma and, in turn, to cause a change in direction of the flow of the fluid over the surface.

For a better understanding of the present invention, embodiments will now be described, by way of example, with reference to the accompanying drawings, in which:-

- 5 -

Figure 1 shows an aircraft wing on which an electrode arrangement in accordance with the present invention is formed;

Figure 2 is a schematic diagram of the apparatus for generating a plasma;

Figure 3 shows the timing of the pulses applied to the electrodes; and

Figure 4 shows in more detail the waveform of the pulses applied to the electrodes.

In the drawings, like elements are generally designated with the same reference numerals.

Figure 1 shows a wing model 1 to which an electrode assembly 3 in accordance with the present invention is attached. The leading edge of the wing 1 is designated 5.

The electrode assembly 3 comprises first and second electrodes 7 and 9.

The electrodes 7 and 9 are similar in shape, and have a generally comb-like structure. Each electrode 7 and 9 comprises a plurality of parallel, vertically extending (in Figure 1) fingers which are connected by a horizontal (in Figure 1) strip. The fingers and the strip of each electrode 7 and 9 are integrally formed with one another. The first electrode 7 has a terminal 11 for connection to a power supply and second electrode 9 has a terminal 13 for connection to a power supply.

In the drawings only a limited number of electrode "fingers" are shown, for the sake of clarity. It will be understood that many more fingers would be employed in an electrode assembly for a commercial aircraft.

The first 7 and second 9 electrodes are interdigitated. As shown in Figure 2, the electrodes 7 and 9 are formed on a sheet 15 of dielectric material, such as a polyester sheet which, in the embodiment, is 250  $\mu\text{m}$  thick. A third, planar sheet electrode 16 is formed on the opposite side of the dielectric layer 15 to the first and second electrodes 7 and 9. The first, second and third electrodes 7, 9 and 16 are formed from copper and are 17  $\mu\text{m}$  thick. The first and second electrodes 7 and 9

- 6 -

are formed by a conventional etching process. The fingers of each of the first and second electrodes 7 and 9 are between 200  $\mu\text{m}$  and 500  $\mu\text{m}$  wide, with each finger being spaced apart from its adjacent finger by 4 mm (adjacent fingers will be of different electrodes).

The first, second and third electrodes 7, 9 and 16 are driven by alternating current high-tension power supply 18.

The electrode assembly 3, comprising the three electrodes 7, 9 and 16 and the dielectric layer 15, is formed as a flexible sheet. The electrode assembly 3 can be adhered to a surface where it is required, such as an aircraft wing or fuselage. The flexibility of the sheet allows the electrode assembly 3 to be attached to curved surfaces, and the electrode assembly 3 is retro-fittable to existing aircraft with minimal structural disruption.

If the aircraft wing, or the structure to which the electrode assembly 3 is attached, is of metal or other electrically conductive material, the third electrode 16 may not be formed, and the conductive structure may be used to provide the function of that electrode by connecting the conductive structure to the power supply 18.

The power supply 18 is configured to alternately drive at the desired span-wise oscillation frequency first electrode 7 and second electrode 9.

Figure 3 shows the duration and timing of the electrical pulses applied to terminals 11 and 13 of the first 7 and second 9 electrodes respectively. The upper oscillation current pulses shown in the Figure are applied to first electrode 7 and the lower oscillation current pulses are applied to second electrode 9. As can be seen, a pulse is never applied to the first 7 and second 9 electrodes at the same time. Each pulse envelope 20 comprises a plurality of shorter duration plasma pulses 22.

- 7 -

The signals have a pulse envelope repetition period  $T$ , determining the span-wise oscillation frequency. The Jung paper "Suppression of Turbulence in Wall-bounded Flows by High Frequency Spanwise Oscillation" referred to above describes how to select a span-wise oscillation frequency range that will reduce drag. Periods of oscillation  $T_{osc}^+$  ranging from 25 to 200 were studied, where

$$T_{osc}^+ = T_{osc} \cdot U_{\tau}^2 / \nu$$

$T_{osc}$  being the oscillation period of the wall

$U_{\tau}$  being the wall friction velocity

$\nu$  being kinematic viscosity.

It was found that  $T_{osc}^+ = 100$  produced the most effective suppression of turbulence.

Within each pulse envelope 20 of the signal is a train of high repetition-rate pulses 22, for example 10 to 100 pulses. Figure 4 shows in more detail the voltage waveform 24 and the current waveform 26 of one pulse 22. The number of pulses 22 within each pulse envelope 20 and the energy of these pulses can be varied to allow adjustment of the impulse imparted to the air in the boundary layer. Generally, the greater the number and the energy of the pulses 20, the greater the effect on the boundary air. However, increasing the number of pulses, and the energy of each pulse will result in increased power consumption. Since, when implemented on an aircraft wing, the device is intended to allow a reduction in fuel consumption of the aircraft engines, there will be no overall saving in energy consumption if the power consumed by the plasma generating apparatus equals the energy saved by the reduction in drag. The energy applied to the pulse generating apparatus should be chosen to reduce the overall energy consumption of the aircraft in flight.

The duration  $D$  of the pulse envelope and the pulse envelope repetition period  $T$  can be independently adjusted.

Plasma is initiated by the high electric field at the first 7 and second 9 electrode/dielectric 15/air triple point 27, and then spreads out, capacitively coupled, to the third, planar electrode 16 on the opposite side of the dielectric layer



- 8 -

15 to the first and second electrodes 7 and 9. The electrode assembly 3 has an inherent capacitance, and additional capacitance when the plasma is formed.

The plasma generates span-wise impulses 28 in the boundary layer at the span-wise oscillation frequency. The impulses 28 are created by the plasma heating and causing expansion of the air in the boundary layer adjacent to the first 7 and second 9 electrodes. The impulses 28 move in a span-wise direction, which is generally perpendicular to the direction 30 of the primary airflow over the aircraft wing 1. It is considered by the present inventors that generating impulses generally perpendicular (within  $\pm 10^\circ$ ) to the principal direction 30 of airflow reduces drag.

Airflow is generated in a span-wise oscillating fashion because adjacent electrodes 7 and 9 are alternatively driven. When the first electrode 7 is driven, as mentioned above, the application of power to the electrode causes the heating and expansion of the air adjacent to the electrode 7. The expanding air will radiate from the electrodes, with components of the expanding air moving in opposite span-wise directions. During the period L when no pulses are applied to any of the electrodes the fluid will continue to flow. When the second electrode 9 is driven the air adjacent to this electrode 9 will also be heated and expand. This expansion will serve to reverse the span-wise movement of the air caused by the previous pulse supplied to the first electrode 7. The repeated alternate application of pulses to the electrode 7 and 9 therefore causes span-wise oscillation of air adjacent to electrodes 7 and 9 on the wing 1 surface. A suitable oscillation frequency range is thought to be between  $10^4$  and  $10^5$  Hz. The value will be chosen according to the location of the electrode assembly 3 on the aircraft and the speed of the aircraft.

In the embodiment the plasma spreads out approximately 4 mm on either side of each of the electrode fingers when a peak voltage of approximately 4 kV is applied.

The power supply 18 may generate a semiconductor switched current pulse which is already at a sufficiently high voltage for plasma generation, or, if not, the

- 9 -

pulse is fired into a step-up transformer. For non-resonant charging of the electrode assembly 3 the output can be taken through a charging resistor. Resonant charging can also be used from a supply with no charging resistor. Current flows and when a plasma generation threshold is exceeded, plasma is generated thereby dissipating power. In the present embodiment, when a sheet 15 of 250µm thick polyester is used for the dielectric material, the plasma generation threshold will be approximately 2 kV. Integrating the voltage and current waveforms shows the energy balance - this rises as the structure charges and then drops as it discharges but not by as much as it rose, the difference is the energy dissipated in the plasma. Multiplying by the plasma pulse repetition rate and the duty cycle gives the average power dissipation. Dividing by the electrode sheet surface area gives the power per unit area. This is an important factor - in order for drag reduction to be efficient, the power per unit area must be less than the power drag reduction of the skin friction. Pulses of both polarities are used for plasma generation.

In the embodiment the pulse rise time is short compared to the pulse period; however, surface plasmas can also be generated with sinusoidal waveforms. As the air reaction to the pulses is much slower it is not anticipated that significant differences to the results would be obtained. Typical energy dissipations per centimetre of electrode length per pulse at 4 kV are approximately 30 µJ. There can be differences between positive and negative polarities but this is an approximate figure. It is estimated that air velocities of  $> 1 \text{ ms}^{-1}$  can be generated within a few millimetres of the first and second electrodes 7 and 9 and close to the surface of the dielectric layer 15.

Of course, variations to the specific embodiment described above are possible without departing from the scope of the invention.

For example, whilst a planar sheet electrode 16 provided on the opposite side of the dielectric layer 15 to the first and second electrodes 7 and 9 is described above, the following arrangement could be employed. A third electrode of a similar configuration to the first and second electrodes 7 and 9 could be

- 10 -

provided. Advantageously, the third electrode may be laterally offset with respect to the first and second electrodes 7 and 9 rather than being positioned directly below the first and second electrodes 7 and 9. Where the lateral offset is small, the plasma generated is generally confined to one side of each of the first and second electrodes 7 and 9. Heating and expansion of the air will generally be in a single direction because the plasma is generated to only one side of the first and second electrodes 7 and 9 in this arrangement. In this embodiment, if the aircraft wing, or the structure to which the electrode assembly 3 is attached, is of metal or other electrically conductive material, an insulator should be provided between the third electrode and conductive structure.

The plasma generating apparatus may be controlled so that it does not operate during take-off and landing of the aircraft, and generally at low altitudes. It may be advantageous not to operate the plasma generating apparatus in these situations for safety reasons - operation may interfere with electronic apparatus in the aircraft and also on the ground, at the airport.

- 11 -

## CLAIMS

1. Apparatus for influencing fluid flow over a surface, the apparatus including a plasma generator comprising first and second spaced-apart independently controllable electrodes operable to cause a change in direction of the flow of the fluid over the surface.
2. Apparatus according to claim 1, wherein the plasma generator is operable to drive the first and second electrodes alternately.
3. Apparatus according to claim any preceding claim, wherein the first and second electrodes are in juxtaposed alignment.
4. Apparatus according to claim 3, wherein the first and second electrodes are in substantially parallel alignment.
5. Apparatus according to claim 4, wherein the first and second electrodes extend generally parallel to the usual direction of motion of the surface in use.
6. Apparatus according to any preceding claim, wherein the plasma generator includes a dielectric that supports the first and second electrodes on a first side thereof.
7. Apparatus according to claim 6, wherein the dielectric is in the form of a flexible sheet.
8. Apparatus according to claim 6 or claim 7, wherein the dielectric comprises a second side that supports a third electrode of the plasma generator, the first and second sides being generally opposed.

- 12 -

9. Apparatus according to any preceding claim, wherein each of the first and second electrodes comprise a plurality of electrically connected elongate elements.

10. Apparatus according to claim 9, wherein the first and second electrodes are arranged such that the elongate elements are interdigitated.

11. Apparatus according to claim 9 or claim 10, wherein the third electrode is planar.

12. Apparatus according to claim 10 or claim 11, wherein the third electrode comprises a plurality of electrically connected elongate elements.

13. Apparatus according to claim 12, wherein the elongate elements of the first, second and third electrodes are in a substantially parallel juxtaposed alignment when viewed facing the first side of the dielectric.

14. Apparatus according to claim 13, wherein the elongate elements of the first, second and third electrodes extend generally parallel to the usual direction of motion of the surface in use.

15. Apparatus according to claim 13 or claim 14, wherein the elongate elements of the third electrode are laterally offset from the elongate elements of the first and second electrodes.

16. An aircraft aerodynamic surface including apparatus according to any one of the preceding claims, wherein the plasma generator is operable to cause a change in direction of the flow of the fluid over the surface.

17. An aircraft including apparatus according to any of claims 1 to 15, wherein the plasma generator is operable to cause a change in direction of the flow of the fluid over the surface.

- 13 -

18. A method of influencing fluid flow over a surface, comprising the step of driving first and second electrodes provided on the surface alternately thereby to generate a plasma and, in turn, to cause a change in direction of the flow of the fluid over the surface.

19. Apparatus, an aerodynamic surface or an aircraft substantially as hereinbefore described with reference to and/or substantially as illustrated in the accompanying drawings.

20. A method of influencing fluid flow over a surface substantially as hereinbefore described with reference to and/or substantially as illustrated in the accompanying drawings.

Fig.1.

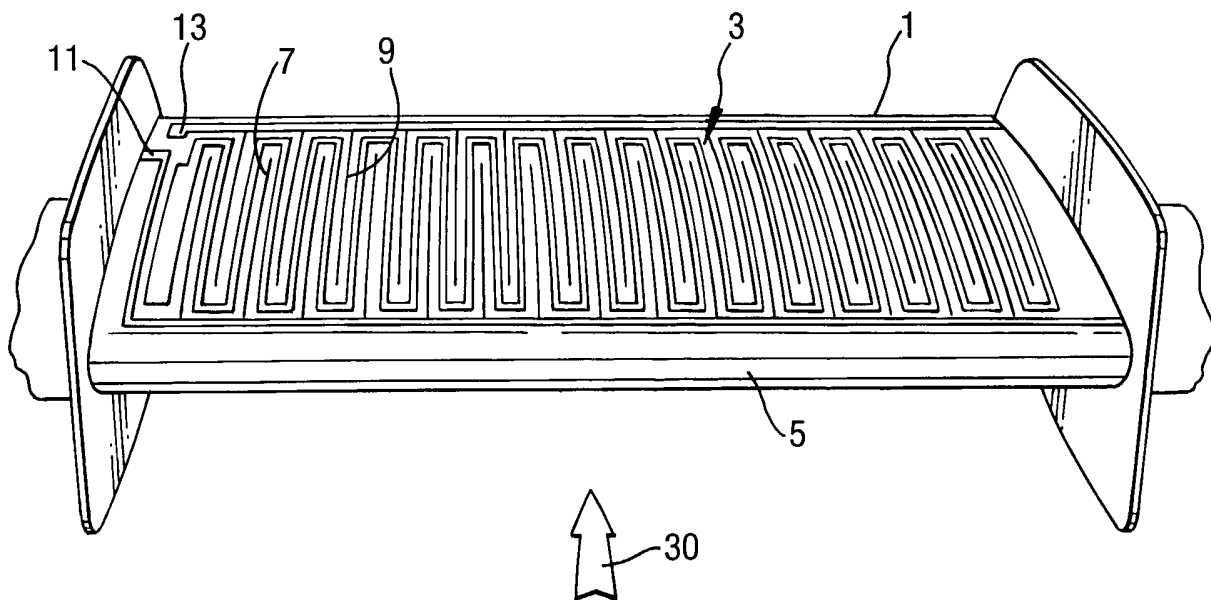

Fig.2.

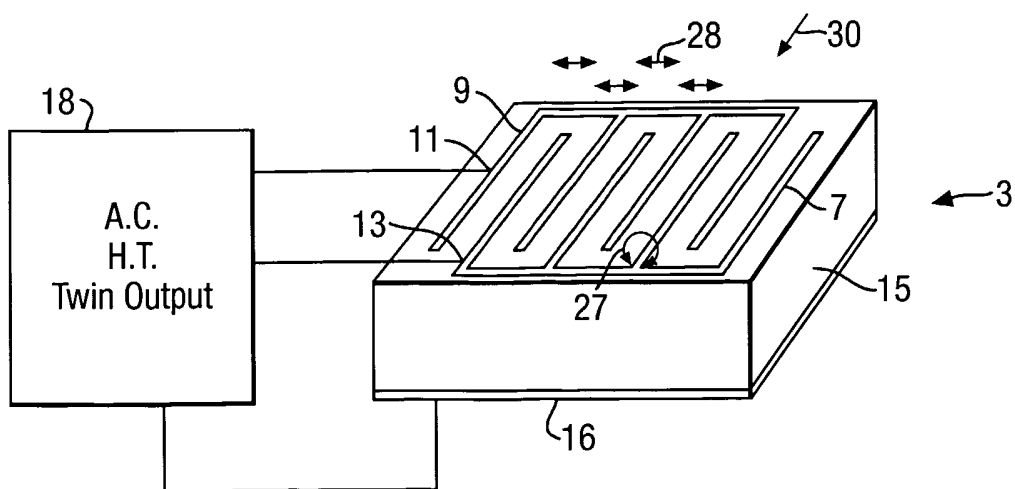

Fig.3.

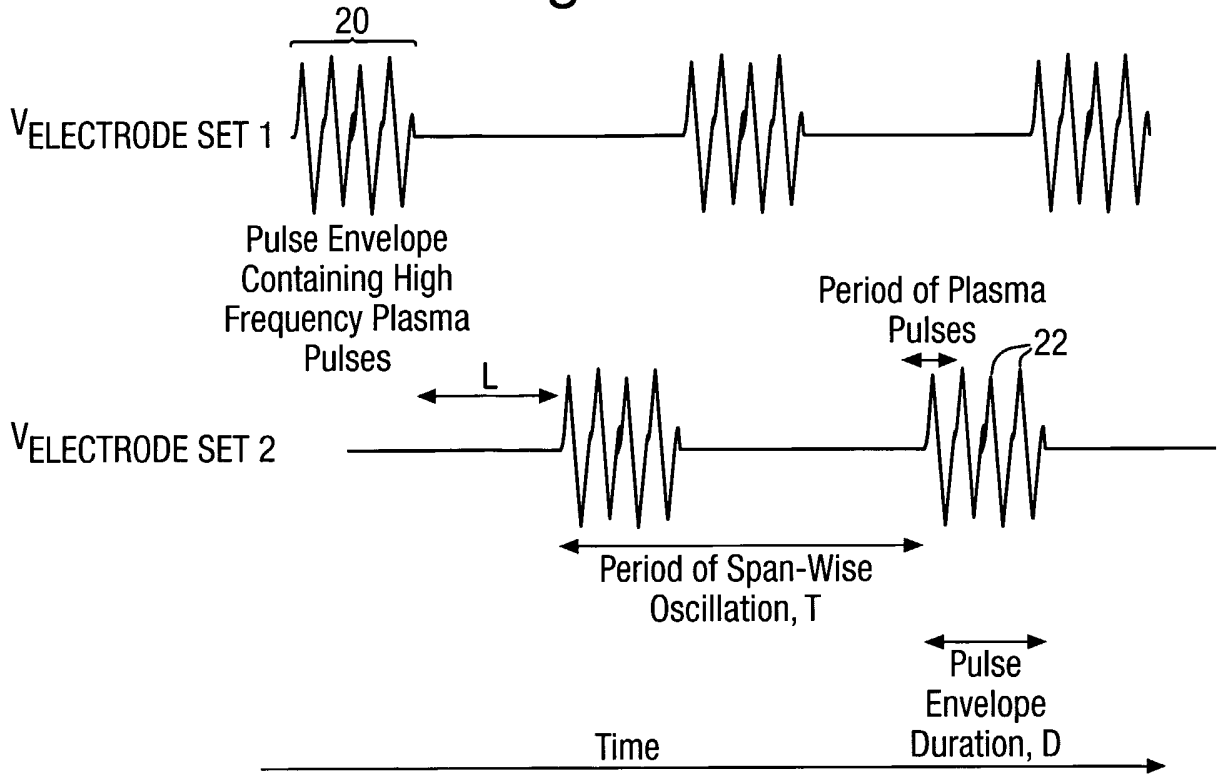
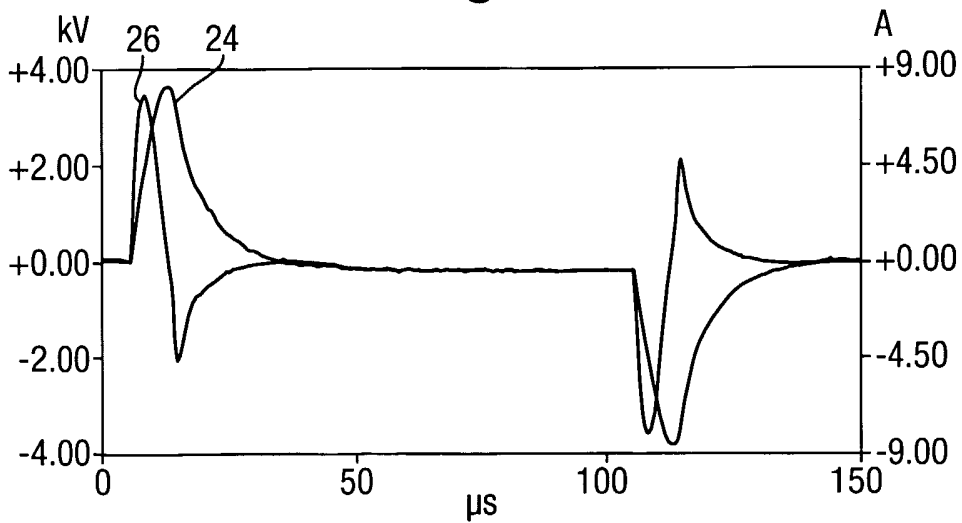

Fig.4.





## INTERNATIONAL SEARCH REPORT

International Application No

PCT/GB 02/01444

<b>A. CLASSIFICATION OF SUBJECT MATTER</b>		
IPC 7	B64C21/00	B64C23/04 B64C21/10 F15D1/12
According to International Patent Classification (IPC) or to both national classification and IPC		
<b>B. FIELDS SEARCHED</b>		
Minimum documentation searched (classification system followed by classification symbols)		
IPC 7 B64C F15D		
Documentation searched other than minimum documentation to the extent that such documents are included in the fields searched		
Electronic data base consulted during the international search (name of data base and, where practical, search terms used)		
EPO-Internal, WPI Data		
<b>C. DOCUMENTS CONSIDERED TO BE RELEVANT</b>		
Category *	Citation of document, with indication, where appropriate, of the relevant passages	Relevant to claim No.
X	US 6 200 539 B1 (WILKINSON STEPHEN P ET AL) 13 March 2001 (2001-03-13) column 1, line 50 -column 2, line 54 column 7, line 34-65 column 8, line 26 -column 9, line 3 column 19, line 35-52 figures 2,3A,3B,3C ---	1-7,9, 10,16-18
X	US 5 669 583 A (ROTH JOHN REECE) 23 September 1997 (1997-09-23) column 3, line 19-25 column 4, line 33-67 column 6, line 3 -column 7, line 12 ---	1-5,9, 16-18
A	US 5 938 854 A (ROTH JOHN REECE) 17 August 1999 (1999-08-17) column 6, line 26-30 column 7, line 55-58; figures 5C,5D,7 --- -/--	6,10
<input checked="" type="checkbox"/> Further documents are listed in the continuation of box C. <input checked="" type="checkbox"/> Patent family members are listed in annex.		
* Special categories of cited documents :		
*A* document defining the general state of the art which is not considered to be of particular relevance *E* earlier document but published on or after the international filing date *L* document which may throw doubts on priority claim(s) or which is cited to establish the publication date of another citation or other special reason (as specified) *O* document referring to an oral disclosure, use, exhibition or other means *P* document published prior to the international filing date but later than the priority date claimed		*T* later document published after the international filing date or priority date and not in conflict with the application but cited to understand the principle or theory underlying the invention *X* document of particular relevance; the claimed invention cannot be considered novel or cannot be considered to involve an inventive step when the document is taken alone *Y* document of particular relevance; the claimed invention cannot be considered to involve an inventive step when the document is combined with one or more other such documents, such combination being obvious to a person skilled in the art. *&* document member of the same patent family
Date of the actual completion of the international search		Date of mailing of the international search report
4 July 2002		16/07/2002
Name and mailing address of the ISA European Patent Office, P.B. 5818 Patentlaan 2 NL - 2280 HV Rijswijk Tel. (+31-70) 340-2040, Tx. 31 651 epo nl, Fax: (+31-70) 340-3016		Authorized officer  Salentiny, G

## INTERNATIONAL SEARCH REPORT

International Application No

PCT/GB 02/01444

C.(Continuation) DOCUMENTS CONSIDERED TO BE RELEVANT		
Category °	Citation of document, with indication, where appropriate, of the relevant passages	Relevant to claim No.
A	US 5 917 286 A (CHRISTIE DAVID J ET AL) 29 June 1999 (1999-06-29) column 7, line 38-63; figure 6 ---	8,11
A	US 5 320 309 A (NOSENCHUCK DANIEL M ET AL) 14 June 1994 (1994-06-14) the whole document -----	1,18

## INTERNATIONAL SEARCH REPORT

Information on patent family members

International Application No

PCT/GB 02/01444

Patent document cited in search report	Publication date	Patent family member(s)	Publication date	
US 6200539	B1	13-03-2001	AU 3180099 A	26-07-1999
			AU 4067799 A	23-08-1999
			WO 9935893 A2	15-07-1999
			WO 9940758 A2	12-08-1999
			US 6406759 B1	18-06-2002
US 5669583	A	23-09-1997	US 5938854 A	17-08-1999
			US 6146724 A	14-11-2000
US 5938854	A	17-08-1999	US 5456972 A	10-10-1995
			US 5669583 A	23-09-1997
			AU 695099 B2	06-08-1998
			AU 6148496 A	18-12-1996
			CA 2222620 A1	05-12-1996
			EP 0828618 A1	18-03-1998
			JP 11507990 T	13-07-1999
			WO 9638311 A1	05-12-1996
			AU 679237 B2	26-06-1997
			AU 6962394 A	20-12-1994
			EP 0700577 A1	13-03-1996
			JP 8511898 T	10-12-1996
			RU 2154363 C2	10-08-2000
			WO 9428568 A1	08-12-1994
			US 5403453 A	04-04-1995
US 6146724 A	14-11-2000			
US 5917286	A	29-06-1999	WO 9742647 A1	13-11-1997
			US 6222321 B1	24-04-2001
US 5320309	A	14-06-1994	AT 186694 T	15-12-1999
			AU 671849 B2	12-09-1996
			AU 4651093 A	24-01-1994
			DE 69327054 D1	23-12-1999
			DE 69327054 T2	08-06-2000
			EP 0646083 A1	05-04-1995
			JP 7508335 T	14-09-1995
			WO 9400342 A1	06-01-1994
			US 5437421 A	01-08-1995