

*A. T. Brewer: Sheet 1 of 4 Sheets*  
*Ordnance Carriage.*  
*N<sup>o</sup> 102,213. Patented Apr. 26, 1870.*  
*Plate I.*

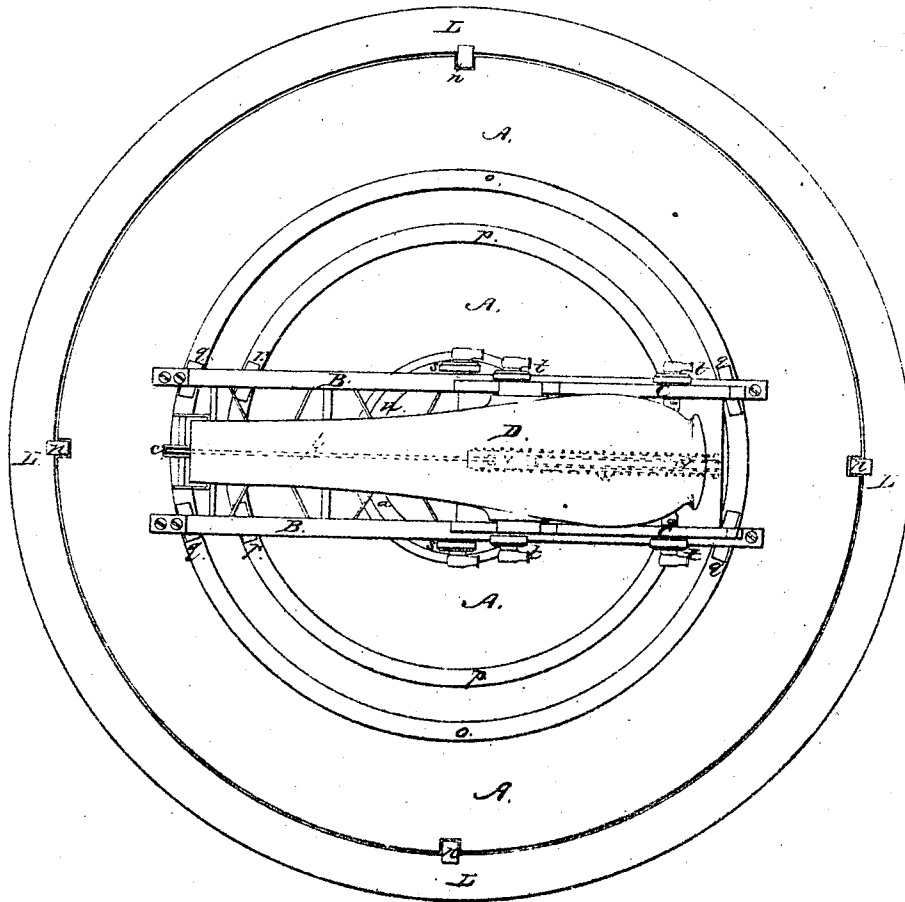

*Witnesses.*

*M. M. Parker*  
*Henry D. Hyde*

*Inventor*

*A. T. Brewer*

*A. T. Brewer* Sheets 4, 5 Sheets  
*Ordnance Carriage.*

*N<sup>o</sup> 102,213.*

*Patented Apr. 26, 1870.*  
*Plate 2.*

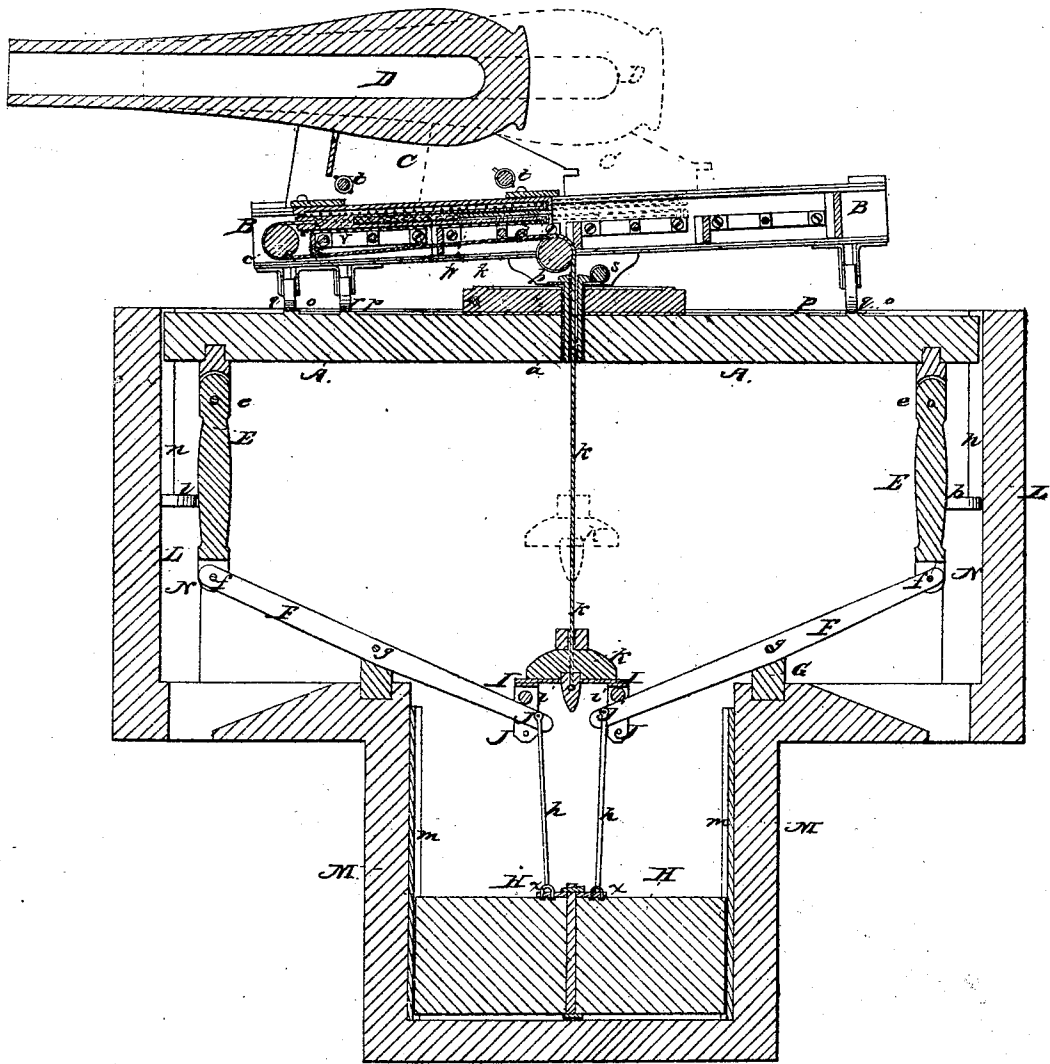

*Witnesses.*

*M. M. Parker*  
*Henry D. Hyde*

*Inventor:*

*A. T. Brewer*

*A. I. Brewer. Sheets 4, Sheets*  
*Ordnance Carriage.*  
*No. 102,213. Patented Apr. 20, 1870.*  
*Plate 3.*

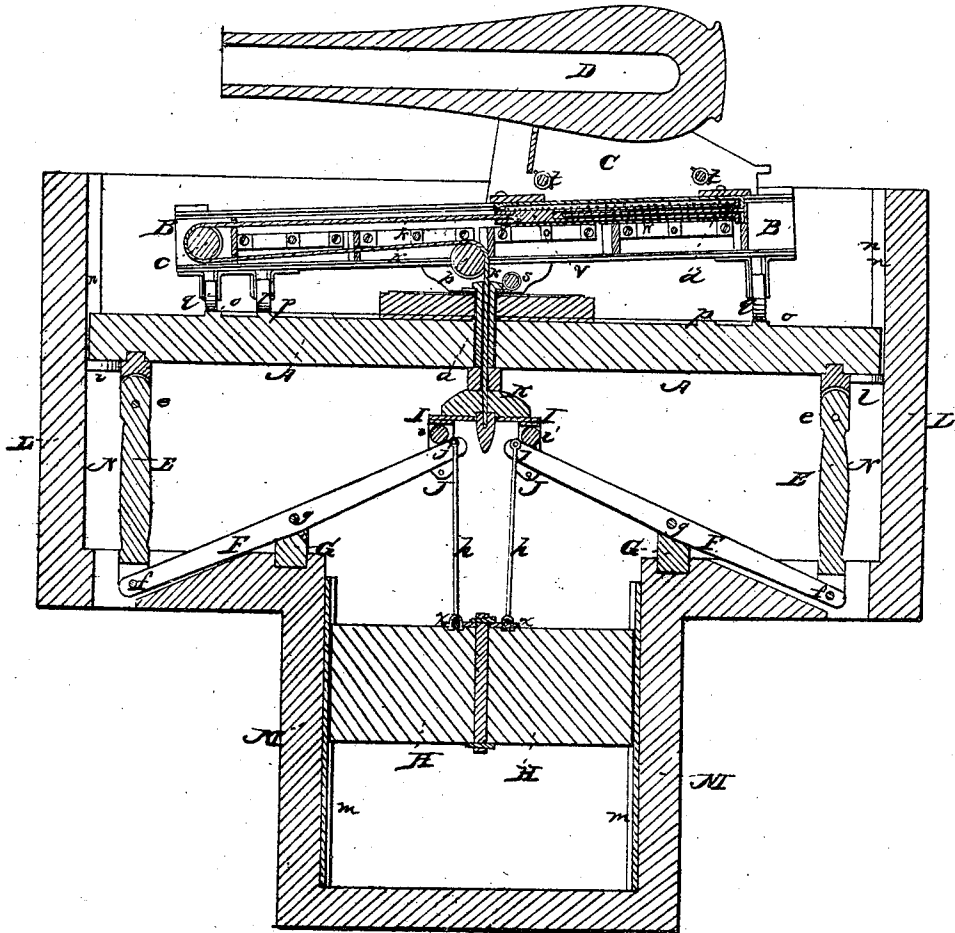

*Witnesses.*

*M. M. Parker*  
*Henry D. Hyde*

*Inventor.*

*A. I. Brewer*

A. T. Brewer: Street 7 1/2 Street 8

Ordnance Carriage.

N<sup>o</sup> 102,213.

Patented Apr. 26, 1870.  
Plate 4.

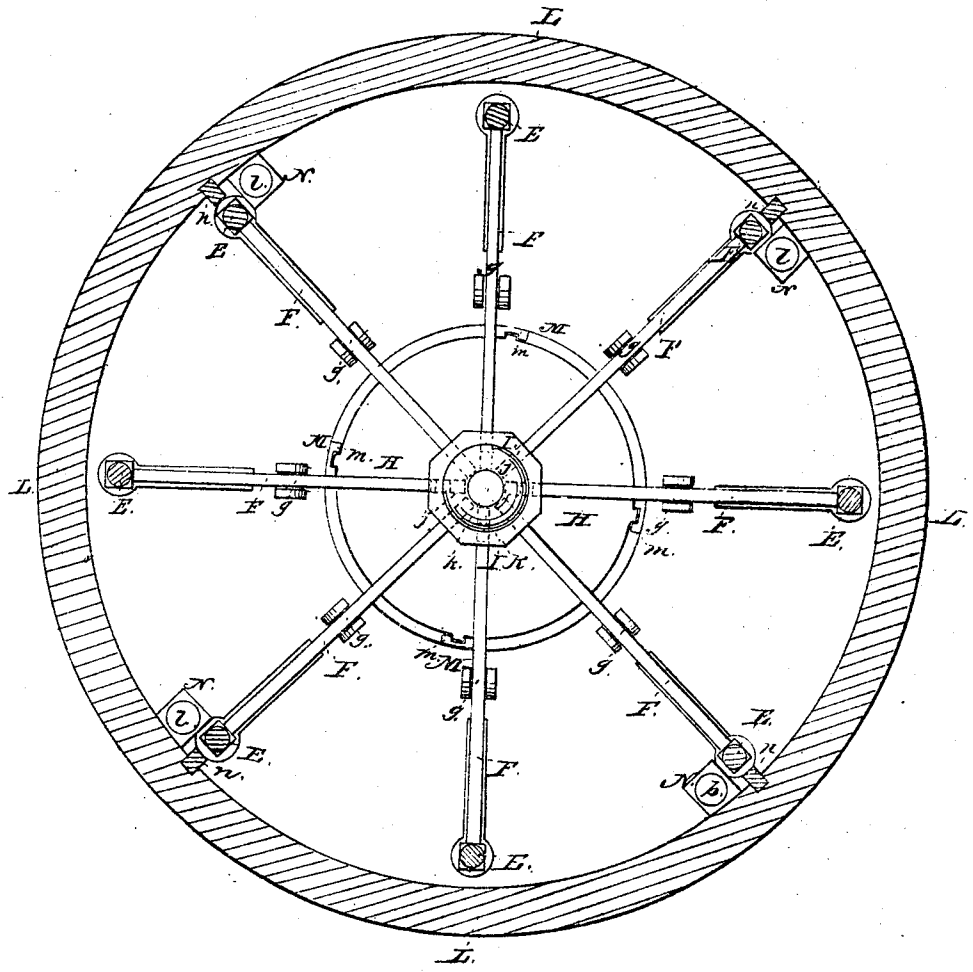

Witnesses.

M. M. Parker  
Henry R. Apple

Inventor.

A. T. Brewer

# United States Patent Office.

ALANSON T. BREWER, OF BRIGHTON, MASSACHUSETTS.

Letters Patent No. 102,213, dated April 26, 1870.

## IMPROVEMENT IN COUNTERPOISE PLATFORMS FOR ORDNANCE.

The Schedule referred to in these Letters Patent and making part of the same.

Be it known that I, ALANSON T. BREWER, of Brighton, in the State of Massachusetts, have invented certain new and useful Improvements in Counterpoising Guns for siege and garrison purposes, of which the following, with the accompanying drawings, is a full description.

Considerable attention has been paid of late to the subject of counterpoising guns and gun-carriages for garrison and siege purposes, so that the gun may be lowered behind and below the parapet to be loaded, and raised above the parapet to be fired. Heretofore inquiries and experiments seem to have been confined to counterpoising guns and their carriages only.

My invention has reference to counterpoising, lowering, and raising not only the gun, or gun and carriage, but the platform on which they rest, thus obtaining more steadiness and uniformity of action, and more certainty of control, as I think. I am also enabled to use the carriages as already constructed, and now in use.

I accomplish my object by placing the platform upon one end or ends of a series of levers, having upon the other end or ends a counterpoise weight, and then, by the transference of an additional weight from one to the other, causing the platform to rise or fall, as desired.

In the drawings—

Plate 1 is a top view of gun and platform.

Plate 2 is a perpendicular sectional view of gun, carriages, platform, levers, weight, &c., when the gun is elevated and in battery.

Plate 3 is a like view when the gun is depressed and recoiled.

Plate 4 is a top view of the lower system of levers, &c.

A A is the platform, upon which is placed the ordinary revolving chassis carriage B B, and upon that the top carriage C, upon which last is the gun D. The drawings are made on a scale of one thirty-second to the inch of a fifteen-inch gun.

The pintle *a* is made hollow.

*o p u* represent the three circles upon which the revolving carriage B traverses upon the wheels *q r s*, (*s* having an eccentric axis.)

*t t* are the eccentric axle-wheels of the top gun-carriage C.

Directly in front of the pintle in the center of the carriage B, under the gun, is placed a pulley, *b*, having its centers on the bottom rails of the carriage, and at the front is placed another pulley, *c*, having its center midway the rails.

On the lower side rear end, midway of the carriage C, is fastened a guide-rod, *d*, surrounded by a stout cylinder or hollow rod, *v*, which is surrounded by a strong spiral spring, *w*.

To the hollow rod *v*, at its front end, is attached a

cord or chain, *k*, passing forward over and around the pulley *c*, and over the pulley *b*, and down through the pintle *a* to the auxiliary or transfer weight K.

The platform A is mounted or suspended upon a series of rods, E, pivoted by knuckle-joints *e* to the platform at their upper ends, and at their lower ends, by joints *f*, to a series of levers, F.

These levers F are hung midway, at *g*, to strong supports G.

At the inner ends of these levers F are hung rods *h*, pivoted to the levers at *j*, and extending downward and pivoted at *x* to the counterpoise weight H, which is equal to the combined weights of gun, carriages, platform, &c., so that the platform will rest at any position up or down.

At the inner extremities of the levers F is placed a small platform, I, having, extending below, brackets or projections J, in which are placed friction-rollers *i*, resting on the tops of the ends of the levers F, and supporting the platform I.

K is a transfer weight attached to the cord or chain *k*, and pulling against the spiral spring *w*.

L is a strong-walled well, of suitable depth, in which the platform A rises and falls.

N are pillars, having upon their tops rubber or other suitable seats, upon which the platform rests when depressed.

M is a strong-walled shaft in which the weight H is placed, and moves up and down.

In the walls of this shaft are placed projecting pillars with grooves *m*, in which move tongues upon the weight, for steadying purposes.

*n* are tongues or tenons attached to the walls L, and fitting into corresponding grooves or mortises in the circumference of the platform, to steady the platform. Friction-rollers will be used on these tongues and grooves.

When the gun is in battery the parts occupy the positions in plate 2. When the gun is fired it recoils backward, and, in so doing, lifts the weight K from its platform I, (where it rested upon the counterpoise ends of the levers,) as shown by the dotted lines, plate 2, and so transfers it to the platform end. As a result, the platform end becomes so much the heavier, and, as the gun goes back to the rear of the chassis carriage, the platform end sinks and the counterpoise rises till they occupy the positions shown in plate 3. The gun is then held in position for loading in the usual manner.

When loaded, and the friction released, the gun rides forward, and the weight K being deposited on its seat I on the counterpoise end of the levers, that becomes so much heavier, and sinks, while the platform rises as the gun rides forward into battery, as shown in plate 2, when it is ready to be fired.

The distances from *e* to *f*, and *f* to *g*, and *g* to *j*, and *j* to *x* are intended to be equal. If the counterpoise is made exactly to balance the platform, carriages, and gun, it will be seen that, when the gun is loaded, considerable weight will be added to the platform end of the lever. The charge of a fifteen-inch gun will weigh some six hundred pounds. In practice it may be found desirable to increase the weight of the counterpoise about one half the weight of the charge, and the transfer or make-weight should probably amount to twelve hundred pounds or thereabout. These weights may be regulated as experience may require.

The first shock of the recoil is relieved by the spiral spring acting against the transfer weight as it rises, and this weight moves more steadily and without jerking. The bearings should be knife-edges, and the levers and rods must be trussed or otherwise made of strength enough for the purpose. The parts can be made of any suitable materials, and strengthened as found desirable.

My intention is to furnish the platform with friction bands, and levers, and ratchets and pawls, so as to be able to stop it, and to hold it at any point, and also to ease its ascent or descent. The recoil of the gun taking it down, and the bringing it into battery carrying it up, no extra men or extra maneuvering or manipulations by the men will be required in handling the piece.

The transfer of the auxiliary weight by other means will not change the principle of my invention.

A front pintle-carriage may be used as well, or, indeed, any kind of a carriage, the proper modifications being made, while the general principle, plan, and mode of operation remain the same.

What I claim is—

1. The gun or piece of ordnance with carriage, platform, and counterpoise weight, when constructed, arranged, and operating in combination, substantially as described.

2. The platform of a siege or garrison-gun or piece of ordnance, in combination with levers and weights, constructed to operate substantially as and for the purposes described.

3. A gun or piece of ordnance with its carriage and platform, in combination with levers and a counterpoise, when constructed, arranged, and operating in such manner that the transfer of an auxiliary or make-weight shall cause the gun to ascend and descend, substantially as and for the purposes described.

4. The construction and arrangement of the auxiliary or make-weight, in combination with the gun and its carriage, in such manner that the recoil of the gun shall transfer the weight from the counterpoise to the carriage, and cause the gun to descend to be loaded, substantially as described.

5. The construction and arrangement of the auxiliary or make-weight, in combination with the counterpoise, in such manner that running the gun into battery shall transfer the weight from the carriage to the counterpoise, and cause the gun to ascend to be fired, substantially as described.

In testimony whereof I have hereunto subscribed my name.

A. T. BREWER

Witnesses:

A. B. ELY,  
W. B. ELY.