



(43) International Publication Date
26 October 2012 (26.10.2012)

- (51) International Patent Classification:
F16H 15/38 (2006.01) *F16H 57/04* (2010.01)
F16H 55/32 (2006.01)
- (21) International Application Number:
PCT/CA2012/000273
- (22) International Filing Date:
26 March 2012 (26.03.2012)
- (25) Filing Language: English
- (26) Publication Language: English
- (30) Priority Data:
61/476,508 18 April 2011 (18.04.2011) US
- (71) Applicant (for all designated States except US): **TRANSMISSION CVTCORP INC.** [CA/CA]; 2101 rue Nobel, Suite N, Sainte-Julie, Québec J3E 1Z8 (CA).
- (72) Inventors; and
- (75) Inventors/Applicants (for US only): **BEAUDOIN, Samuel** [CA/CA]; 139, Rang de l'Île Domaine Est, Yamaska, Québec J0G 1X0 (CA). **MCMAHON, Christian** [CA/CA]; 4838, St-Urbain, #2, Montréal, Québec H2T 2N2 (CA). **OKULOV, Paul** [CA/CA]; 12, Senneville Road, Ste-Anne-de-Bellevue, Québec H9X 1B5 (CA).
- (74) Agent: **PRINCE, Gaétan**; 25th floor, 1100, Rene-Levesque boul. West, Montréal, Québec H3B 5C9 (CA).

(81) Designated States (unless otherwise indicated, for every kind of national protection available): AE, AG, AL, AM, AO, AT, AU, AZ, BA, BB, BG, BH, BR, BW, BY, BZ, CA, CH, CL, CN, CO, CR, CU, CZ, DE, DK, DM, DO, DZ, EC, EE, EG, ES, FI, GB, GD, GE, GH, GM, GT, HN, HR, HU, ID, IL, IN, IS, JP, KE, KG, KM, KN, KP, KR, KZ, LA, LC, LK, LR, LS, LT, LU, LY, MA, MD, ME, MG, MK, MN, MW, MX, MY, MZ, NA, NG, NI, NO, NZ, OM, PE, PG, PH, PL, PT, QA, RO, RS, RU, RW, SC, SD, SE, SG, SK, SL, SM, ST, SV, SY, TH, TJ, TM, TN, TR, TT, TZ, UA, UG, US, UZ, VC, VN, ZA, ZM, ZW.

(84) Designated States (unless otherwise indicated, for every kind of regional protection available): ARIPO (BW, GH, GM, KE, LR, LS, MW, MZ, NA, RW, SD, SL, SZ, TZ, UG, ZM, ZW), Eurasian (AM, AZ, BY, KG, KZ, MD, RU, TJ, TM), European (AL, AT, BE, BG, CH, CY, CZ, DE, DK, EE, ES, FI, FR, GB, GR, HR, HU, IE, IS, IT, LT, LU, LV, MC, MK, MT, NL, NO, PL, PT, RO, RS, SE, SI, SK, SM, TR), OAPI (BF, BJ, CF, CG, CI, CM, GA, GN, GQ, GW, ML, MR, NE, SN, TD, TG).

Published:

— with international search report (Art. 21(3))

(54) Title: CONTINUOUSLY VARIABLE TRANSMISSION PROVIDED WITH A ROLLER PARKING ZONE

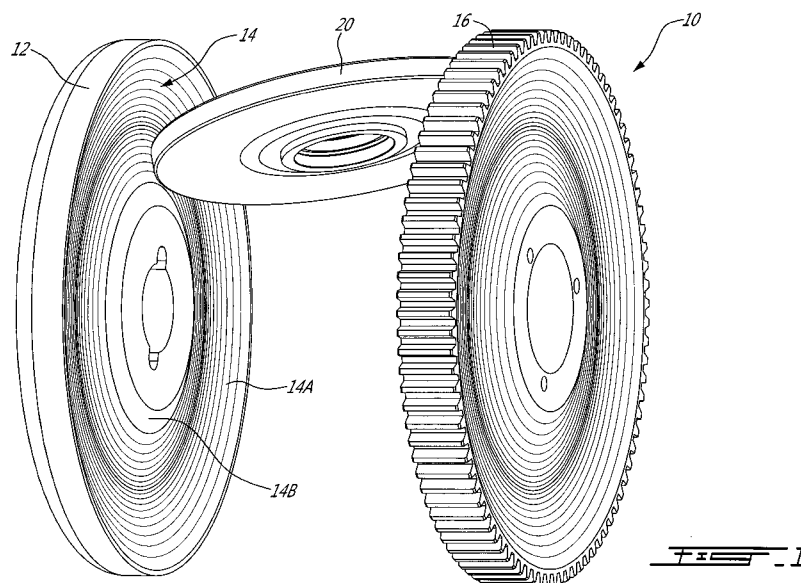

(57) Abstract: Generally stated, various embodiments described herein concern a toroidal CVT provided with parking zones where the rollers are brought when the CVT is powered down. More specifically, a portion of the toroidal surfaces of the disks is reserved as a parking zone therefore preventing premature wear and/or damages to the working portion of the disks.



TITLE

Continuously Variable Transmission provided with a roller parking zone.

FIELD

[0001] The present invention relates to traction drive toroidal continuously variable transmissions. More specifically, the present invention is concerned with such a transmission provided with roller parking zones to prevent possible damage to the surfaces of the working zones.

BACKGROUND

[0002] Toroidal Continuously Variable Transmissions (hereinafter generically referred to as "CVT") are believed well known in the art. The operation of such a CVT will therefore only be briefly discussed herein.

[0003] Generally stated, a toroidal CVT is provided with a drive disk having a toroidal surface, a driven disk also having a toroidal surface facing the toroidal surface of the drive disk. Both disks being linked by rollers in contact with their respective toroidal surfaces. The angle of the rollers with respect to the drive and driven disks dictates the speed ratio between the driven and drive disks.

[0004] Often, toroidal CVTs are designed according to the so-called "dual cavity" configuration including two drive disks and a single driven disk having opposed toroidal surfaces and located between the two drive disks.

[0005] A clamping mechanism is conventionally used to bias the disks towards one another to therefore ensure that the rollers are adequately contacted by both the driving and the driven disks to thereby transfer torque therebetween. However, this clamping mechanism may cause premature wear of portions of the disks and rollers caused by vibrations to which the CVT may be subjected when the CVT is not in operation, for example during transport or maintenance thereof.

[0006] Indeed, while the CVT is in operation, a thin film of traction oil is present between the contacting surfaces of the rollers and disks. This film of oil is not maintained when the CVT is stopped or operated under low rotational speeds. Accordingly, when no oil film is present the metal-to-metal contact between the rollers and disks in conjunction with acting forces may cause damages in the form of scratches and other marks on both the disks and the rollers that may cause a premature wear of these surfaces. These forces may take the form of vibrations that occur during transportation (unit in a trailer while being transported over the road, railroad associated vibration or vibration occurring on a mobile application where the CVT is at rest while being moved from one site to another), when a unit is not operating but is positioned next to a vibration source such as an operating prime mover, or caused by the engine startup/shutdown torque spikes.

[0007] Generally speaking, the wear occurring during transport is going to be caused by fretting, which generates marks and scratches over the disk and roller surfaces and produces metallic debris. The metallic debris may enter the traction oil reservoir to thereby contaminate it and eventually cause more damages to be created on the rollers and disks. Furthermore, microstructural damage to the material may be caused, which is very difficult to detect.

BRIEF DESCRIPTION OF THE DRAWINGS

[0008] In the appended drawings:

[0009] Figure 1 is a perspective view of one of the cavity of a dual-cavity toroidal CVT according to a first illustrative embodiment;

[0010] Figure 2 is a front elevation view of the CVT of Figure 1 shown in an overdrive position;

[0011] Figure 3 is a front elevation view of the CVT of Figure 1 shown in an underdrive position;

[0012] Figure 4 is a front elevation view of the CVT of Figure 1 shown in a parked position;

[0013] Figure 5 is a close-up view of a portion of a roller and a portion of a disk when the roller is in the parked position of Figure 4;

[0014] Figures 6 and 6A are close-up views similar to Figure 5 but illustrating a portion of a disk according to a second illustrative embodiment;

[0015] Figure 7 is a close-up view similar to Figure 5 but illustrating a portion of a disk according to a third illustrative embodiment;

[0016] Figure 8 is a close-up view similar to Figure 5 but illustrating a portion of a disk according to a fourth illustrative embodiment;

[0017] Figure 9 is a close-up view similar to Figure 5 but illustrating a portion of a disk according to a fifth illustrative embodiment;

[0018] Figure 10 is a close-up view similar to Figure 5 but illustrating a portion of a disk according to a sixth illustrative embodiment.

DETAILED DESCRIPTION

[0019] The use of the word “a” or “an” when used in conjunction with the term “comprising” in the claims and/or the specification may mean “one”, but it is also consistent with the meaning of “one or more”, “at least one”, and “one or more than one”. Similarly, the word “another” may mean at least a second or more.

[0020] As used in this specification and claim(s), the words “comprising” (and any form of comprising, such as “comprise” and “comprises”), “having” (and any form of having, such as “have” and “has”), “including” (and any form of including, such as “include” and “includes”) or “containing” (and any form of containing, such as “contain” and “contains”), are inclusive or open-ended and do not exclude additional, unrecited elements or process steps.

[0021] In the present specification in the appended claims, various terminology which is directional, geometrical and/or spatial in nature such as “longitudinal”, “horizontal”, “front”, “rear”, “upwardly”, “downwardly”, etc. is used. It is to be understood that such terminology is used for ease of description and in a relative sense only and is not to be taken in any way as a limitation upon the scope of the present disclosure.

[0022] It is to be noted that the expression “damages”, when related to the disks and rollers, is to be construed herein and in the appended claims as any scratches, marks, indentations, smearing, adhesive wear, microstructural damage, plastic deformations and the like of these surfaces.

[0023] Other objects, advantages and features of the CVT will become more apparent upon reading of the following non-restrictive description of illustrative embodiments thereof, given by way of example only with reference to the accompanying drawings.

[0024] In an illustrative embodiment, there is provided a continuously variable transmission comprising:

 a first disk provided with a first toroidal surface defining a first working zone and a first parking zone;

 a second disk provided with a second toroidal surface defining a second working zone and a second parking zone; the second toroidal surface facing the first toroidal surface;

 at least one roller in contact with both the first and second toroidal surfaces;

wherein, a) when the CVT is in operation, the at least one roller is in contact with both the first and second working zones and b) when the CVT is not in operation, the at least one roller is in contact with both the first and second parking zones.

[0025] According to another aspect, there is provided a method to prevent damages to the working zones of a toroidal CVT, the method comprising:

providing a first disk having a first toroidal surface defining a first working zone and a first parking zone;

providing a second disk having a second toroidal surface defining a second working zone and a second parking zone; the second toroidal surface facing the first toroidal surface;

providing at least one roller in contact with both the first and second toroidal surfaces;

wherein, a) when the CVT is in operation, the at least one roller is maintained in contact with both the first and second working zones and b) when the CVT is not in operation, the at least one roller is maintained contact with both the first and second parking zones.

[0026] Generally stated, various embodiments described herein concern a toroidal CVT provided with parking zones where the rollers are brought when the CVT is powered down. More specifically, a portion of the toroidal surfaces of the disks is reserved as a parking zone therefore preventing premature wear and/or damage of the working portion of the disks.

[0027] Turning now to Figures 1 to 5 of the appended drawings, which illustrate a portion of a dual-cavity toroidal CVT 10 according to a first illustrative embodiment. The CVT 10 includes a first disk 12 having a toroidal surface 14; a second disk 16 having a toroidal surface 18 (see Figure 2) facing the toroidal surface 14; a plurality of rollers 20 (only one shown for clarity purpose) in contact with both toroidal surfaces 14 and 18.

[0028] As can be seen from Figure 1, the toroidal surface 14 is virtually divided into an outer working zone 14A and an inner parking zone 14B. Similarly, Figure 2 shows that the toroidal surface 18 is virtually divided into an inner working zone 18A and an outer parking zone 18B.

[0029] Figure 2 shows the rollers 20 of the CVT 10 in an overdrive position, since the disk 12 is the transmission input and the disk 16 is the transmission output. This overdrive position is a first limit of the working zone of the CVT 10. It is to be noted that the rollers 20 contact the disks 12 and 16 at the limit of the toroidal surfaces 14 and 18.

[0030] Similarly, Figure 3 shows the rollers 20 of the CVT 10 in an underdrive position, which is a second limit of the working zone of the CVT 10. It is to be noted that the rollers 20 contact the disks 12 and 16 at the limit of the working zones 14A and 18A of the toroidal surfaces 14 and 18.

[0031] During the CVT operation, the rollers 20 may be pivoted between the positions illustrated in Figures 2 and 3 to provide a desired transmission ratio between the first disk 12 and the second disk 16.

[0032] As can be seen from Figure 4, when the CVT 10 is not operational, the rollers 20 are pivoted so that they are in contact with the parking zones 14B and 18B of the toroidal surfaces 14 and 18. Accordingly, should the CVT be vibrated, for example during transport, maintenance, start-up/shutdown or any other situation when the transmission isn't rotating, the working zones 14A and 18A of the respective toroidal surfaces 14 and 18 remain free of scratches

and wear since there is no contact between the rollers 20 and the working zones 14A and 18A.

[0033] One skilled in the art will understand that the movements of the rollers are controlled by a controller (not shown) that can act on the rollers via actuators (not shown). The controller generally has inputs that are associated with the prime mover (not shown) to be in a position to know that a shut down or start-up is imminent, for example.

[0034] Figure 5 is a close-up view of the roller 20 in contact with the parking zone 14B of the toroidal surface 14.

[0035] Turning now to Figures 6-6A of the appended drawings, which are close-up views similar to Figure 5, illustrating a portion of a CVT 100 according to a second illustrative embodiment. It is to be noted that since the CVT 100 is very similar to the CVT 10 illustrated in Figures 1 to 5 and described hereinabove, only the differences therebetween will be discussed hereinbelow.

[0036] Generally stated, the shape of the parking zone 102B is modified with respect to the shape of the parking zone 14B. More specifically, the radius of the parking zone 102B is greater than the radius of the adjacent working zone 102A. The transition between the radiuses of the parking and working zones being seamless.

[0037] Accordingly, as can be seen in Figure 6A, only a portion of the roller 20 contacts the parking zone 102B and the contacting surface of the roller 20 is therefore less likely to be damaged by vibration when it is parked. As a result

the scratches and wear is not only controlled to be avoided on the operating surfaces of the disks but also on the surfaces of the rollers 20 since the potential wear and scratches will now occur on the side surface of the roller, a section that isn't used in operation.

[0038] Of course, the other disk (not shown) also has this parking zone shape.

[0039] Turning now to Figure 7 of the appended drawings, which is a close-up view similar to Figure 5, illustrating a portion of a CVT 200 according to a third illustrative embodiment. It is to be noted that since the CVT 200 is very similar to the CVT 10 illustrated in Figures 1 to 5 and described hereinabove, only the differences therebetween will be discussed hereinbelow.

[0040] Generally stated, the shape of the parking zone 202B is modified with respect to the shape of the parking zone 14B. More specifically, the radius of the parking zone 202B is smaller than the radius of the working zone 202A. The transition between the radiuses of the parking and working zones being seamless.

[0041] Accordingly, only the portions of the rollers 20 that are not used during operation contact the parking zone 202B therefore no damage can occur on the operational portions of the roller surfaces.

[0042] Of course, the other disk (not shown) also has this parking zone shape.

[0043] Turning now to Figure 8 of the appended drawings, which is a close-up view similar to Figure 5, illustrating a portion of a CVT 300 according to a fourth illustrative embodiment. It is to be noted that since the CVT 300 is very similar to the CVT 10 illustrated in Figures 1 to 5 and described hereinabove, only the differences therebetween will be discussed hereinbelow.

[0044] Generally stated, the shape of the parking zone 302B is modified with respect to the shape of the parking zone 14B. More specifically, the parking zone 302B has a radial offset with respect to the working zone 302A. Accordingly, only a corner portion of the roller 20 contacts the parking zone 302B. As mentioned above, this protects the roller 20 operating surface from being damaged by vibration when it is parked.

[0045] Of course, the other disk (not shown) also has this parking zone shape.

[0046] Turning to Figure 9 of the appended drawings, which is a close-up view similar to Figure 5, illustrating a portion of a CVT 400 according to a fifth illustrative embodiment. It is to be noted that since the CVT 400 is very similar to the CVT 10 illustrated in Figures 1 to 5 and described hereinabove, only the differences therebetween will be discussed hereinbelow.

[0047] Generally stated, the contact surface of the parking zone 402B is provided with a softer metal insert 404 onto which the roller 20 is parked. Accordingly, since the metal insert 404 is softer than the metal forming the roller 20, it is less likely that the contact surface of the roller 20 will be damaged by vibration when the roller 20 is parked. The softer material insert, for example

brass, could also be replaced by a special coating or any other material (not shown) that can reduce or prevent wear between contacting surfaces. Of course, other types of materials could be made into an insert such as 404.

[0048] One skilled in the art will understand that instead of having a softer metal insert 404, the rollers could be made of harder metal so that any vibration occurring when the rollers are in the parking zone causes wear on the disks and not on the rollers. It is believed that a two to four Rockwell C unit (2 to 4 HRC) difference is sufficient between the materials forming the rollers and the disks.

[0049] Finally turning to Figure 10 of the appended drawings, which is a close-up view similar to Figure 5, illustrating a portion of a CVT 500 according to a sixth illustrative embodiment. It is to be noted that since the CVT 500 is very similar to the CVT 10 illustrated in Figures 1 to 5 and described hereinabove, only the differences therebetween will be discussed hereinbelow.

[0050] Generally stated, the contact surface of the parking zone 502B is provided with a groove 504 over which the roller 20 is parked. Accordingly, since the working portion of the roller 20 is registered with the groove 504 when parked, it is less likely that the contact surface of the roller 20 will be damaged by vibration.

[0051] One skilled in the art will understand that many more elements are required for a toroidal CVT to properly operate. These elements were omitted from the present disclosure and from the appended drawings since they are not concerned with the present invention.

[0052] One skilled in the art will understand that while a dual-cavity toroidal CVT was described herein, the basic principles described herein apply to single cavity toroidal CVTs and to half toroidal CVTs.

[0053] Of course, one skilled in the art will understand that the rollers are brought in the parking zone while the disks are rotating. Similarly, the rollers are moved out of the parking zones while the disks are rotating. All under the control of the transmission electronic controller (not shown). This is interesting since, at start-up and/or shutdown of a prime mover (not shown), connected to one of the disks 12 and 16, some harmful vibrations may be induced in the transmission by the prime mover. Since the electronic controller may be configured so as to bring and keep the rollers in the parking zones when the prime mover is starting up or shutting down, these induced vibrations are less likely to cause surface deterioration on the rollers and/or disks.

[0054] Furthermore, at start-up and/or shutdown, i.e. when the CVT is powered up or powered down, the oil film (not shown) provided on the disks to prevent premature wear thereof, may be insufficient. The electronic controller may thus be configured so as to wait for a predetermined speed to be reached after the prime mover is starting up so that an adequate oil film is present on the disks surfaces before the rollers are brought in contact with the working zones. One skilled in the art should be in a position to determine the predetermined speed according to the CVT parameters.

[0055] It is also to be noted that the disk 12 is viewed as an input disk and that the disk 16 is viewed as an output disk. Accordingly, the parking zones are provided near the center of rotation of the disk 12 and near the periphery of

the disk 16 so as to park the rollers in an underdrive configuration. Should the disk 12 be an output disk and the disk 16 be an input disk, the position of the parking zones could be reversed. This underdrive parking is interesting since it minimizes the inertia viewed from the prime mover at start-up. Of course, one could decide to design a transmission where the parking zones are in an overdrive position of the rollers or elsewhere if the application requires it.

[0056] One skilled in the art will understand that the shape of the rollers 20 and of the toroidal surfaces 14, 18, 102, 202, 302 and 402 have been exaggerated herein for illustration purposes. It is believed that one skilled in the art will be in a position to design rollers and toroidal surfaces according to the above teachings while providing more efficient contact surfaces, for example.

It is to be understood that the CVT is not limited in its application to the details of construction and parts illustrated in the accompanying drawings and described hereinabove. The CVT is capable of other embodiments and of being practiced in various ways. It is also to be understood that the phraseology or terminology used herein is for the purpose of description and not limitation. Hence, although the CVT has been described hereinabove by way of illustrative embodiments thereof, it can be modified, without departing from the spirit, scope and nature of the subject invention.

What is claimed is:

1. A continuously variable transmission comprising:

a first disk provided with a first toroidal surface defining a first working zone and a first parking zone;

a second disk provided with a second toroidal surface defining a second working zone and a second parking zone; the second toroidal surface facing the first toroidal surface;

at least one roller in contact with both the first and second toroidal surfaces;

wherein, a) when the CVT is in operation, the at least one roller is in contact with both the first and second working zones and b) when the CVT is not in operation, the at least one roller is in contact with both the first and second parking zones.

2. A continuously variable transmission as recited in claim 1, wherein the first disk is an input disk and the second disk is an output disk.

3. A continuously variable transmission as recited in claim 2, wherein the input disk has an inner parking zone and an outer working zone; and wherein the output disk has an inner working zone and an outer parking zone.

4. A continuously variable transmission as recited in claim 1, wherein the at least one roller includes three rollers.

5. A continuously variable transmission as recited in claim 1, wherein the parking zones of the first and second disks have surfaces provided with a radius different from the radius of the surfaces of the working zones of the first and second disks.

6. A continuously variable transmission as recited in claim 5, wherein the radius of the parking zones is greater than the radius of the working zones.

7. A continuously variable transmission as recited in claim 5, wherein the transition between the radius of the parking zone and the radius of the working zone is seamless.

8. A continuously variable transmission as recited in claim 1 wherein the parking zones of the first and second disks have surfaces provided with a radial offset with respect to the radius of the surfaces of the working zones of the first and second disks.

9. A continuously variable transmission as recited in claim 1, wherein the parking zones of the first and second disks have inserts made of a wear reducing material.

10. A continuously variable transmission as recited in claim 9, wherein the wear reducing material includes brass.

11. A continuously variable transmission as recited in claim 9, wherein the insert are in the form of a wear reducing coating.

12. A continuously variable transmission as recited in claim 1, wherein the parking zones of the first and second disks have a groove preventing a contact between a portion of the at least one roller and the first and second disks.

13. A continuously variable transmission as recited in claim 1, wherein the hardness of the material forming the roller is from about 2 HRC to about 4 HRC harder than the material forming the first and second parking zones.

14. A method to prevent damages to the working zones of a toroidal CVT, the method comprising:

providing a first disk having a first toroidal surface defining a first working zone and a first parking zone;

providing a second disk having a second toroidal surface defining a second working zone and a second parking zone; the second toroidal surface facing the first toroidal surface;

providing at least one roller in contact with both the first and second toroidal surfaces;

wherein, a) when the CVT is in operation, the at least one roller is maintained in contact with both the first and second working zones and b) when the CVT is not in operation, the at least one roller is maintained contact with both the first and second parking zones.

15. A damage preventing method as recited in claim 14, further comprising bringing the at least one roller in contact with the first and second parking zones when the CVT is powered down.

16. A damage preventing method as recited in claim 14, further comprising bringing the at least one roller in contact with the first and second working zones when the CVT is powered up and has reached a predetermined input speed.

17. A damage prevention method as recited in claim 14, wherein the first disk is an input disk and the second disk is an output disk.

18. A damage prevention method as recited in claim 17, wherein the input disk has an inner parking zone and an outer working zone; and wherein the output disk has an inner working zone and an outer parking zone.

19. A damage prevention method as recited in claim 14, wherein the at least one roller providing step includes providing three rollers.

20. A damage prevention method as recited in claim 14, wherein the parking zones of the first and second disks have surfaces provided with a radius different from the radius of the surfaces of the working zones of the first and second disks.

21. A damage prevention method as recited in claim 20, wherein the radius of the parking zones is greater than the radius of the working zones.

22. A damage prevention method as recited in claim 20, wherein the transition between the radius of the parking zone and the radius of the working zone is seamless.

23. A damage prevention method as recited in claim 14, wherein the parking zones of the first and second disks have surfaces provided with a radial offset with respect to the radius of the surfaces of the working zones of the first and second disks.

24. A damage prevention method as recited in claim 14, wherein the parking zones of the first and second disks have inserts made of a wear reducing material.

25. A damage prevention method as recited in claim 14, wherein the wear reducing material includes brass.

26. A damage prevention method as recited in claim 14, wherein the insert are in the form of a wear reducing coating.

27. A damage prevention method as recited in claim 14, wherein the parking zones of the first and second disks have a groove preventing a contact between a portion of the at least one roller and the first and second disks.

28. A damage prevention method as recited in claim 14, wherein the hardness of the material forming the roller is from about 2 HRC to about 4 HRC harder than the material forming the first and second parking zones.

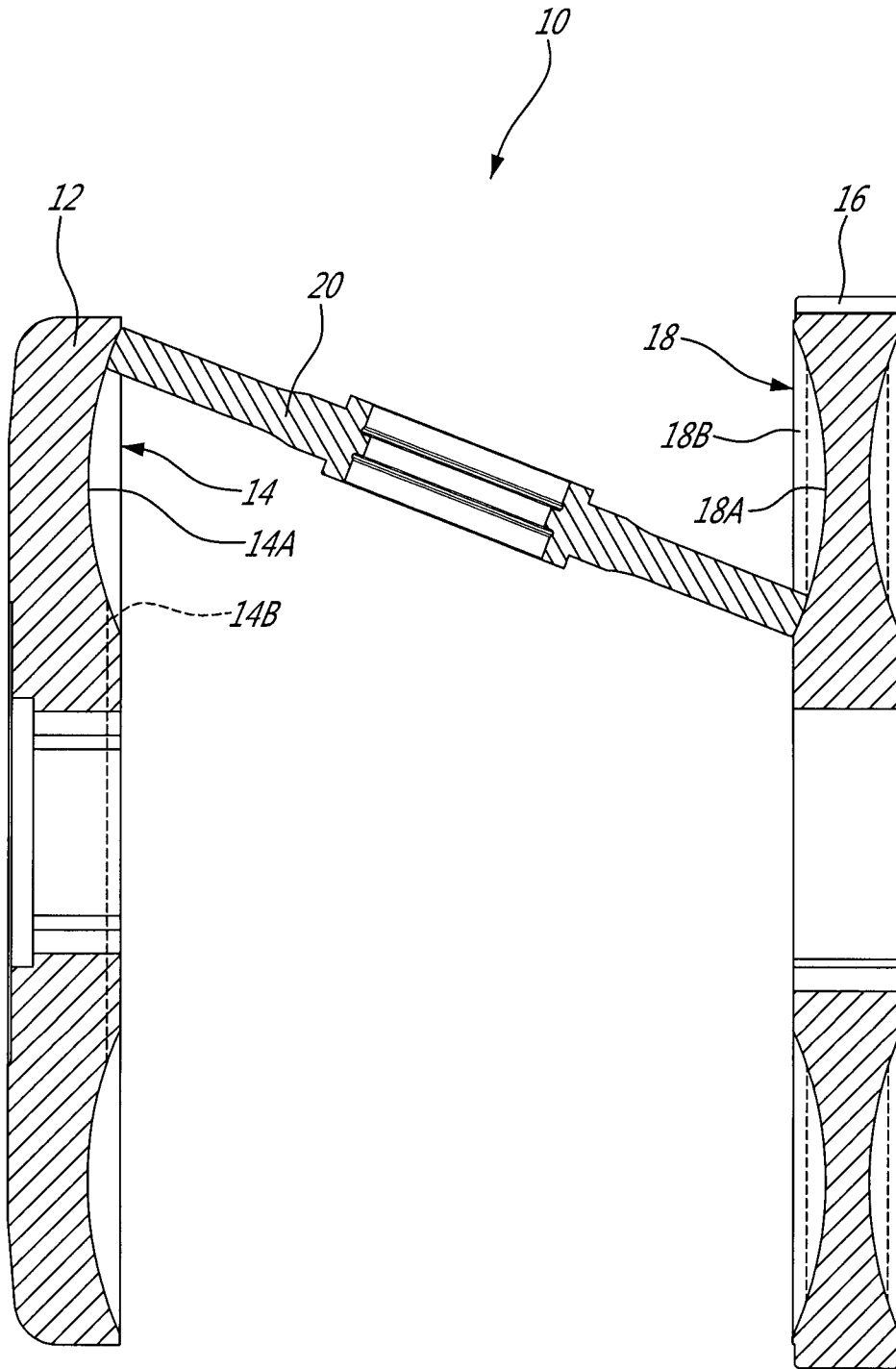

FIG. 2

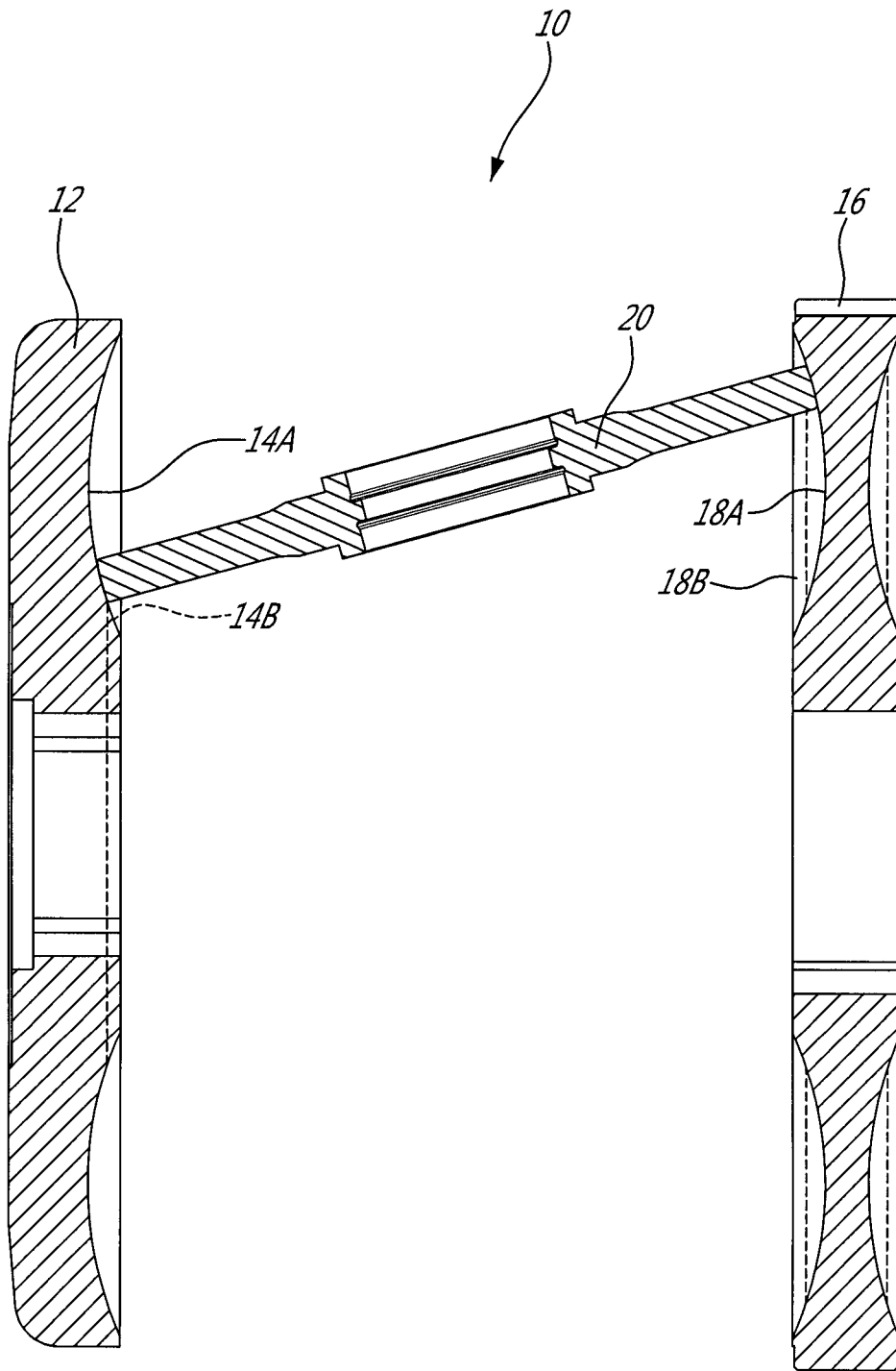

FIG. 3

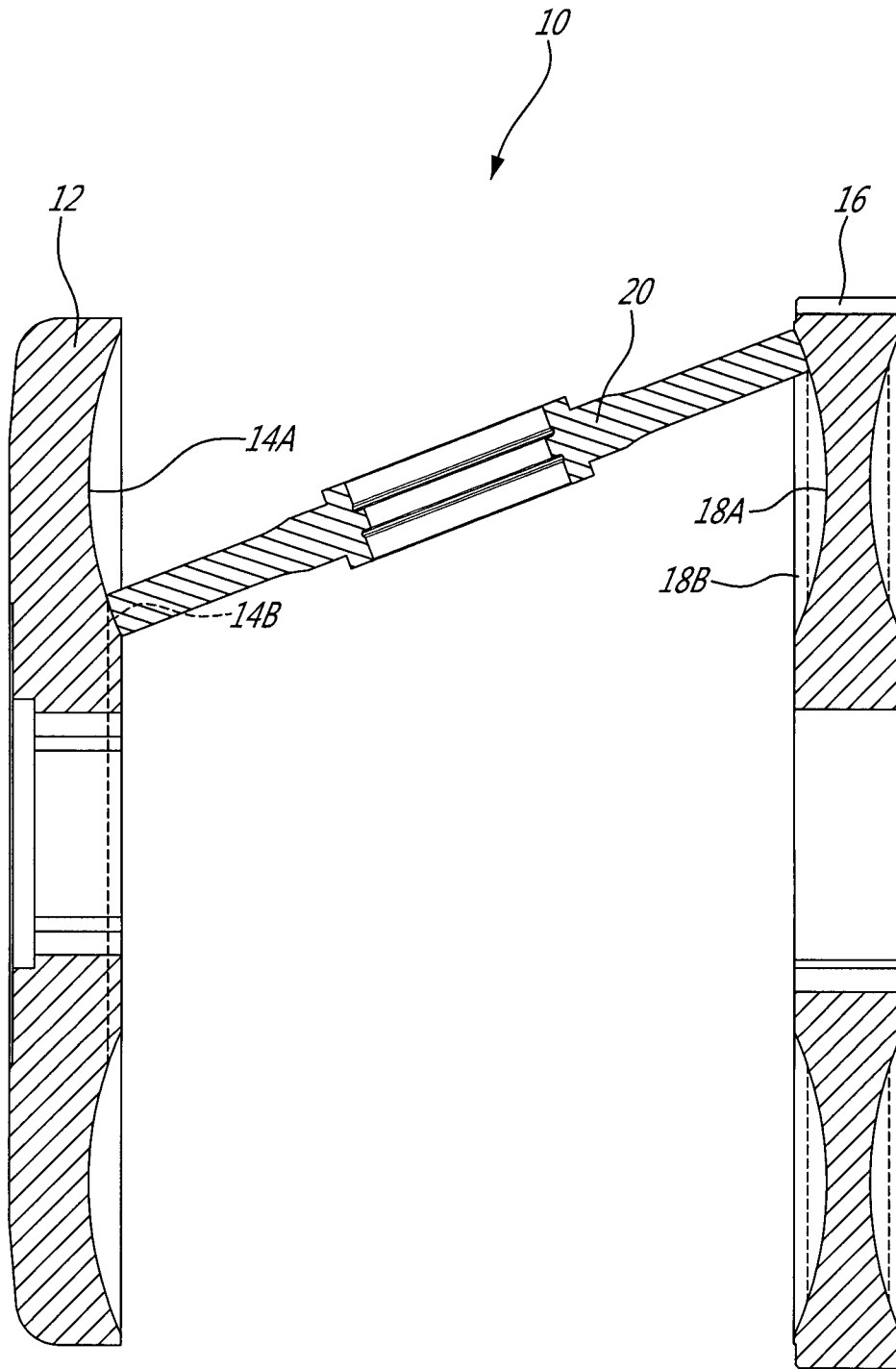
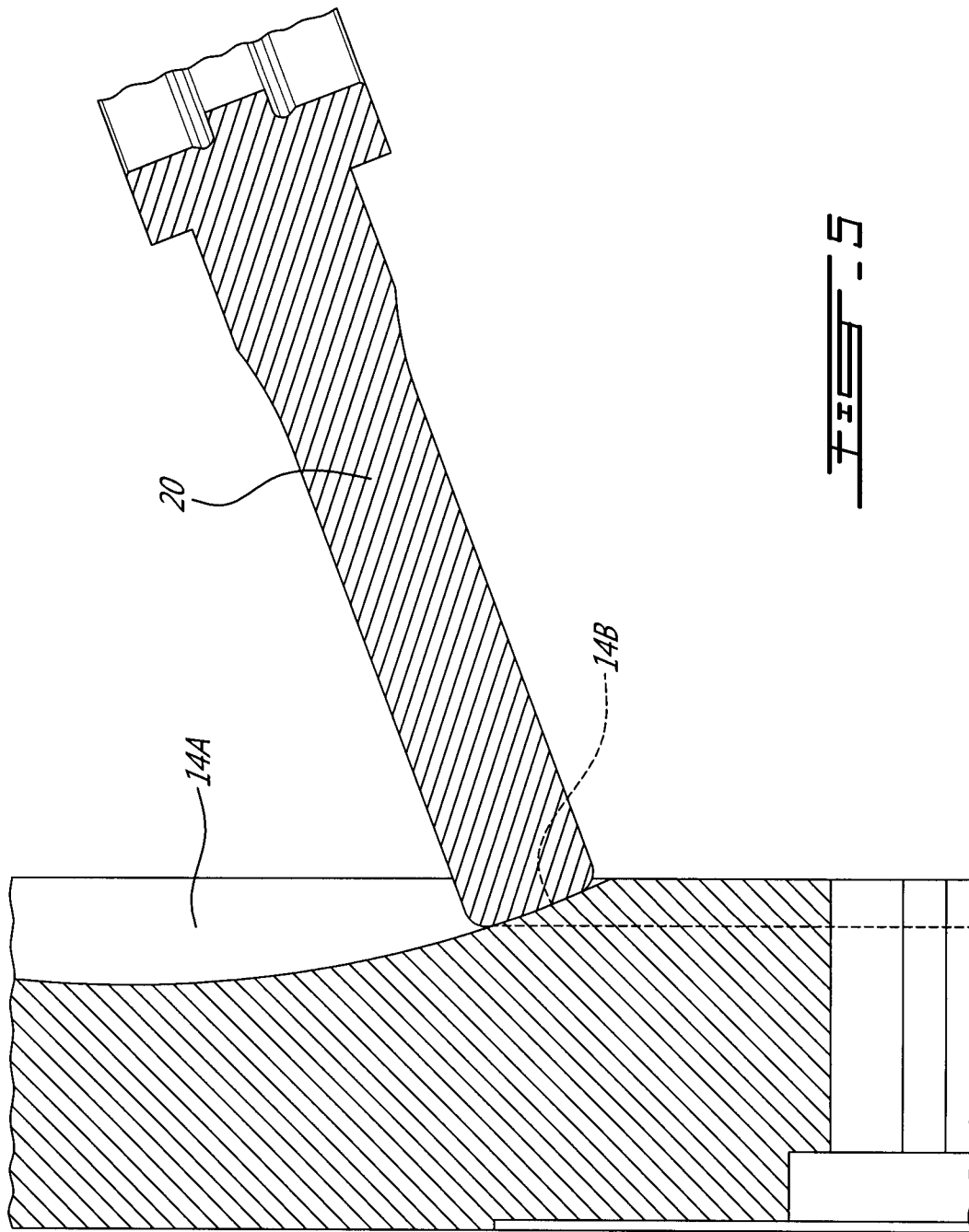
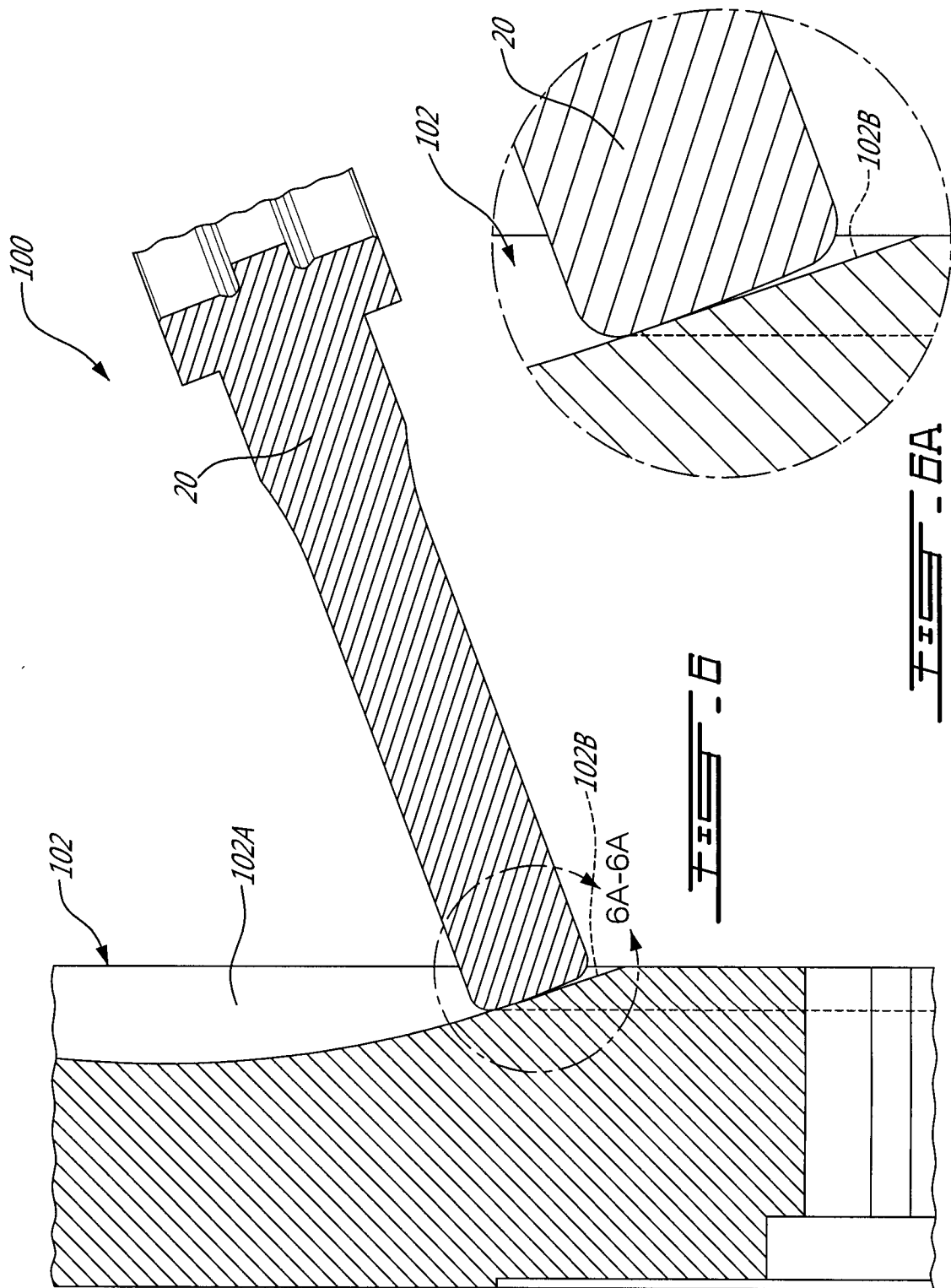
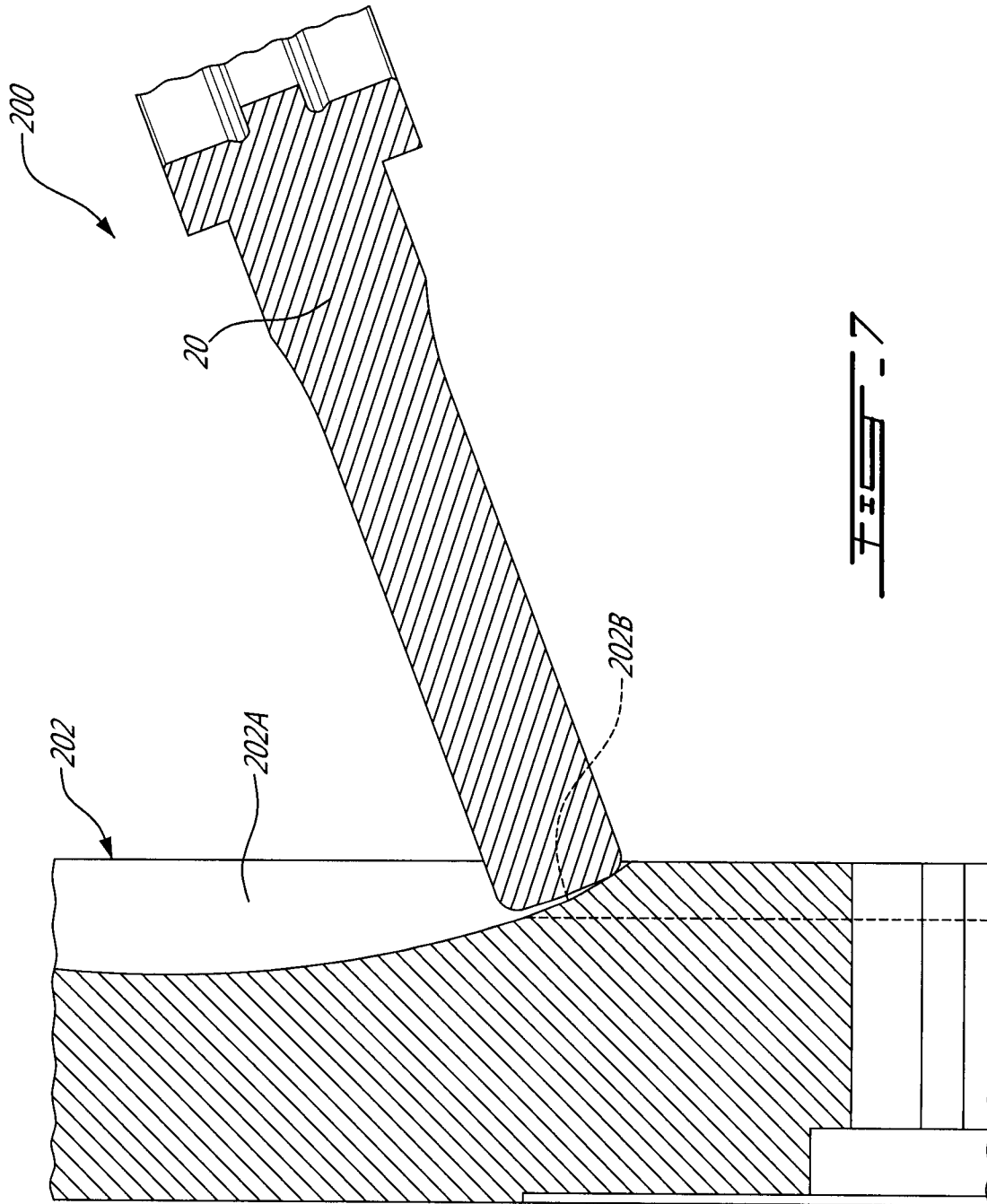
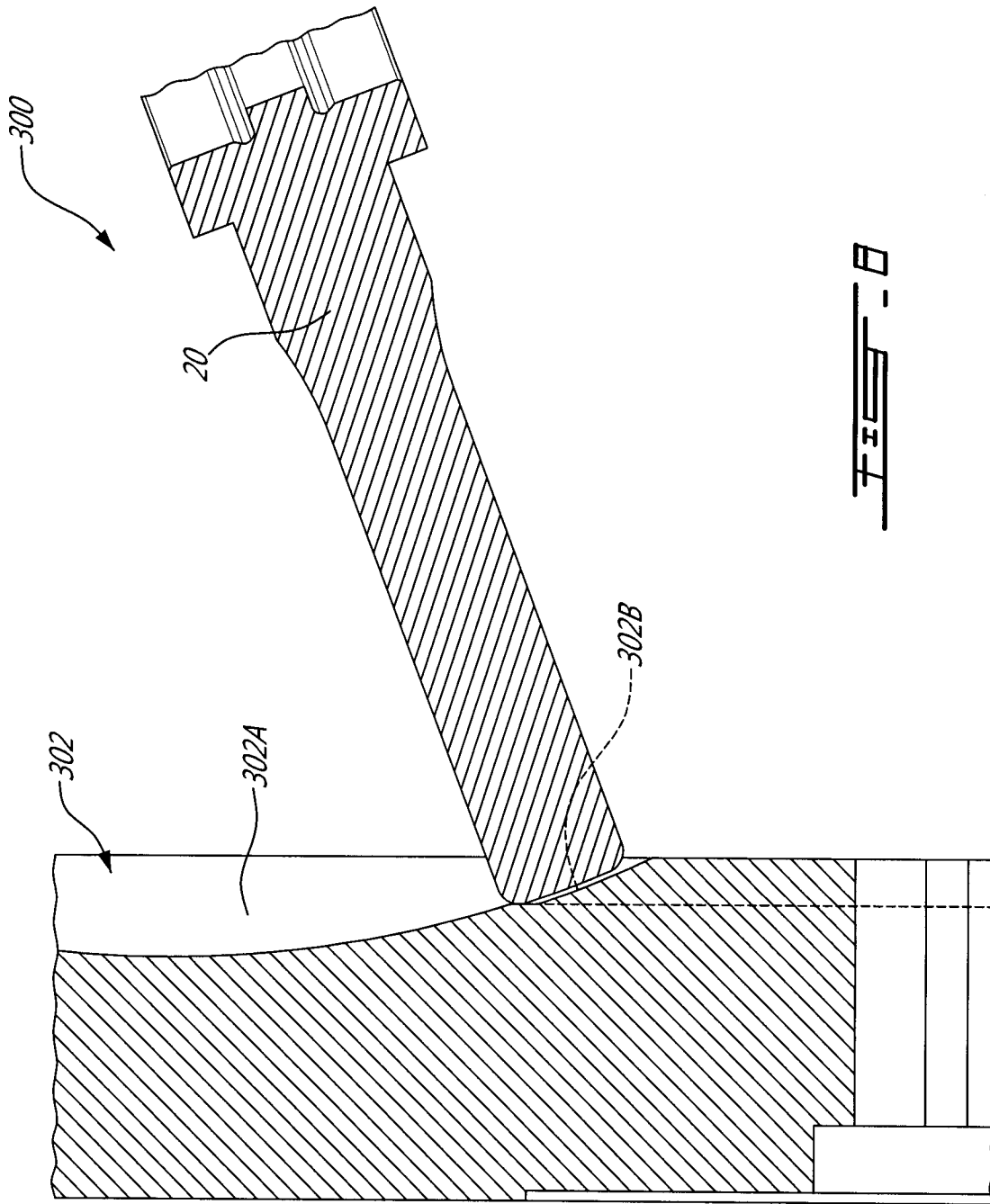

FIG. 4









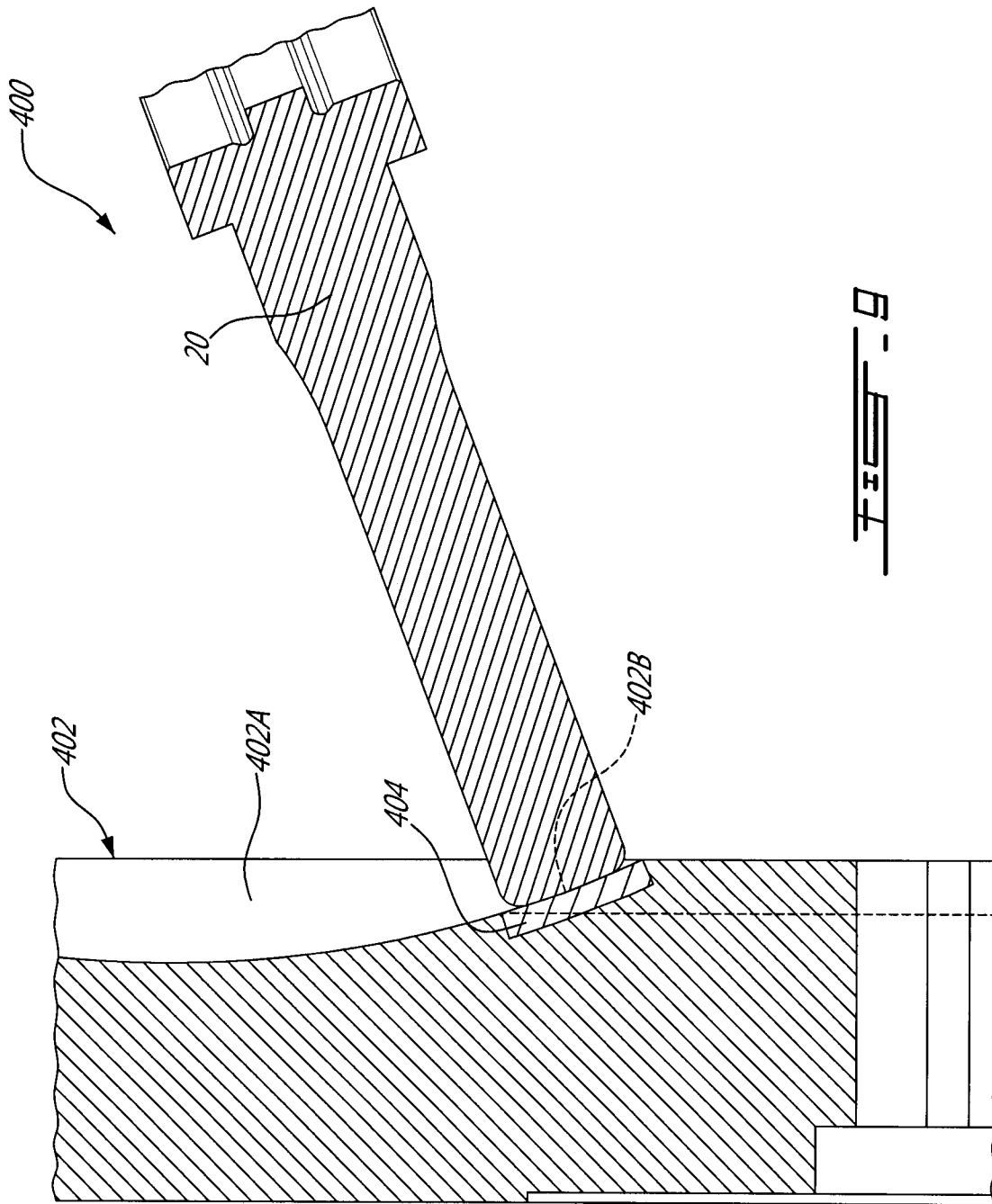

FIG. 9

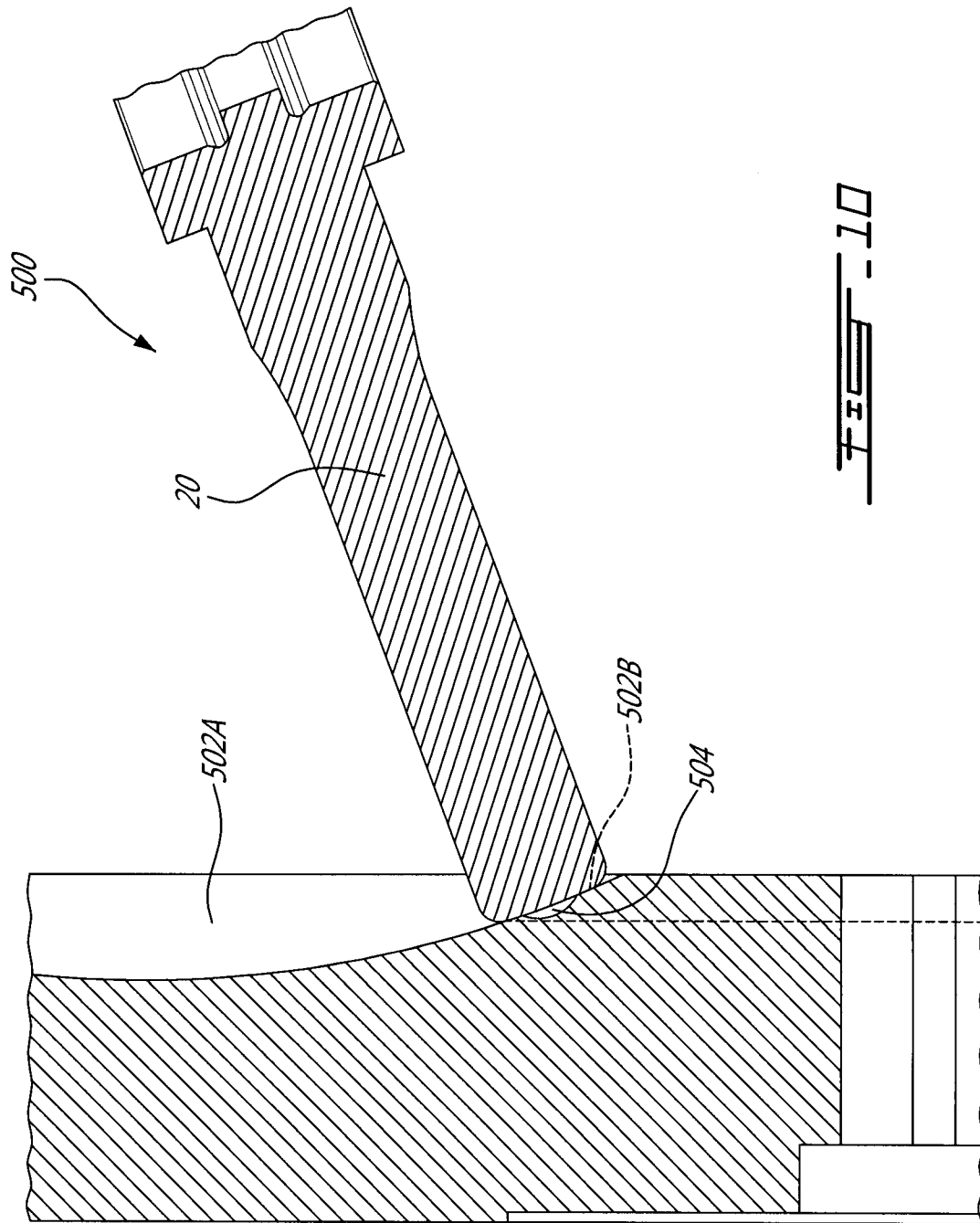

FIG. 10

INTERNATIONAL SEARCH REPORT

International application No.
PCT/CA2012/000273

A. CLASSIFICATION OF SUBJECT MATTER
 IPC: **F16H 15/38** (2006.01) , **F16H 55/32** (2006.01) , **F16H 57/04** (2010.01)
 According to International Patent Classification (IPC) or to both national classification and IPC

B. FIELDS SEARCHED
 Minimum documentation searched (classification system followed by classification symbols)
 IPC: **F16H 15/38** (2006.01) , **F16H 55/32** (2006.01) , **F16H 57/04** (2010.01)

Documentation searched other than minimum documentation to the extent that such documents are included in the fields searched

Electronic database(s) consulted during the international search (name of database(s) and, where practicable, search terms used)
 Epoque (Epodoc, X-FULL); Canadian patent Database with key words such as: continuously variable, toroidal, zone, disk, disc, park+, radius, insert, etc.

C. DOCUMENTS CONSIDERED TO BE RELEVANT

Category*	Citation of document, with indication, where appropriate, of the relevant passages	Relevant to claim No.
A	US3727474 A (FULLERTON, R. L.) 17 April 1973 (17-04-1973) *whole document*	1 - 28
A	US6464616 B1 (KAMAMURA, Y. et al.) 15 October 2002 (15-10-2002) *whole document*	1 - 28
A	US6527667 B2 (OSHIDARI, T. et al.) 04 March 2003 (04-03-2003) *whole document*	
A	US20020068659 A1 (HIRAI, E. et al.) 06 June 2002 (06-06-2002) *whole document*	
A	US20070204940 A1 (HARADA, H. et al.) 06 September 2007 (06-09-2007) *whole document*	

Further documents are listed in the continuation of Box C. See patent family annex.

* Special categories of cited documents :	"T" later document published after the international filing date or priority date and not in conflict with the application but cited to understand the principle or theory underlying the invention
"A" document defining the general state of the art which is not considered to be of particular relevance	"X" document of particular relevance, the claimed invention cannot be considered novel or cannot be considered to involve an inventive step when the document is taken alone
"E" earlier application or patent but published on or after the international filing date	"Y" document of particular relevance, the claimed invention cannot be considered to involve an inventive step when the document is combined with one or more other such documents, such combination being obvious to a person skilled in the art
"L" document which may throw doubts on priority claim(s) or which is cited to establish the publication date of another citation or other special reason (as specified)	"&" document member of the same patent family
"O" document referring to an oral disclosure, use, exhibition or other means	
"P" document published prior to the international filing date but later than the priority date claimed	

Date of the actual completion of the international search 09 May 2012 (09-05-2012)	Date of mailing of the international search report 18 May 2012 (18-05-2012)
---	--

Name and mailing address of the ISA/CA Canadian Intellectual Property Office Place du Portage I, C114 - 1st Floor, Box PCT 50 Victoria Street Gatineau, Quebec K1A 0C9 Facsimile No.: 001-819-953-2476	Authorized officer Julia Zhu (819) 997-5173
---	---

INTERNATIONAL SEARCH REPORT
Information on patent family members

International application No.
PCT/CA2012/000273

Patent Document Cited in Search Report	Publication Date	Patent Family Member(s)	Publication Date
US 3727474 A	17 April 1973 (17-04-1973)	None	
US 6464616 B1	15 October 2002 (15-10-2002)	DE10028610A1 DE10028610B4 JP2000352449A JP4172095B2	31 May 2001 (31-05-2001) 02 December 2004 (02-12-2004) 19 December 2000 (19-12-2000) 29 October 2008 (29-10-2008)
US 6527667 B2	04 March 2003 (04-03-2003)	DE60136887D1 EP1167819A2 EP1167819A3 EP1167819B1 JP2002089644A JP3736619B2 US2002002098A1	22 January 2009 (22-01-2009) 02 January 2002 (02-01-2002) 23 May 2007 (23-05-2007) 10 December 2008 (10-12-2008) 27 March 2002 (27-03-2002) 18 January 2006 (18-01-2006) 03 January 2002 (03-01-2002)
US 2002068659 A1	06 June 2002 (06-06-2002)	DE60143735D1 EP1199495A2 EP1199495A3 EP1199495B1 JP2003074660A JP4107556B2 US6814685B2	10 February 2011 (10-02-2011) 24 April 2002 (24-04-2002) 02 July 2003 (02-07-2003) 29 December 2010 (29-12-2010) 12 March 2003 (12-03-2003) 25 June 2008 (25-06-2008) 09 November 2004 (09-11-2004)
US 2007204940 A1	06 September 2007 (06-09-2007)	DE602007000826D1 EP1826460A1 EP1826460B1 JP2007262572A	20 May 2009 (20-05-2009) 29 August 2007 (29-08-2007) 08 April 2009 (08-04-2009) 11 October 2007 (11-10-2007)