



US009536893B2

(12) **United States Patent**
Hsiao et al.

(10) **Patent No.:** **US 9,536,893 B2**
(45) **Date of Patent:** **Jan. 3, 2017**

(54) **THREE-DIMENSIONAL MEMORY AND METHOD FOR MANUFACTURING THE SAME**

(71) Applicant: **MACRONIX INTERNATIONAL CO., LTD.**, Hsinchu (TW)

(72) Inventors: **Yi-Hsuan Hsiao**, Hsinchu (TW); **Wei-Chen Chen**, Taoyuan County (TW)

(73) Assignee: **MACRONIX INTERNATIONAL CO., LTD.**, Hsinchu (TW)

(*) Notice: Subject to any disclaimer, the term of this patent is extended or adjusted under 35 U.S.C. 154(b) by 0 days.

(21) Appl. No.: **14/541,169**

(22) Filed: **Nov. 14, 2014**

(65) **Prior Publication Data**

US 2016/0141300 A1 May 19, 2016

(51) **Int. Cl.**

- H01L 21/283** (2006.01)
- H01L 23/48** (2006.01)
- H01L 23/535** (2006.01)
- H01L 21/768** (2006.01)
- H01L 23/528** (2006.01)
- H01L 27/115** (2006.01)

(52) **U.S. Cl.**

CPC ... **H01L 27/11582** (2013.01); **H01L 27/11575** (2013.01)

(58) **Field of Classification Search**

CPC H01L 27/1157; H01L 27/11582; H01L 27/115; H01L 27/11524; H01L 27/11521
USPC 257/321, E21.422, E21.69, E27.103; 438/257, 258, 264, 593, 286
See application file for complete search history.

(56) **References Cited**

U.S. PATENT DOCUMENTS

- 6,696,334 B1 * 2/2004 Hellig H01L 21/823864 257/E21.64
- 2002/0058380 A1 * 5/2002 Parekh H01L 27/10894 438/253
- 2007/0210372 A1 * 9/2007 Park H01L 27/115 257/321
- 2008/0067554 A1 3/2008 Jeong et al.
- 2008/0157092 A1 * 7/2008 Arai H01L 27/115 257/67
- 2011/0241114 A1 10/2011 Su et al.
- 2012/0181701 A1 * 7/2012 Chen H01L 23/50 257/774

FOREIGN PATENT DOCUMENTS

- TW 200816460 A 4/2008
- TW 201135928 A 10/2011

OTHER PUBLICATIONS

TIPO Office Action dated May 19, 2016 in Taiwan application (No. 103139462).

* cited by examiner

Primary Examiner — Kimberly Rizkallah

Assistant Examiner — Brian Turner

(74) *Attorney, Agent, or Firm* — McClure, Qualey & Rodack, LLP

(57) **ABSTRACT**

A three-dimensional (3D) memory and a method for manufacturing the same are disclosed. According to one embodiment, the 3D memory comprises a thin-film transistor. The thin-film transistor has a source region and a drain region disposed separately. The source region comprises a first source region and a second source region disposed between the first source region and the drain region. The first source region is p-type of doping, the second source region is n-type of doping, and the drain region is n-type of doping.

8 Claims, 11 Drawing Sheets

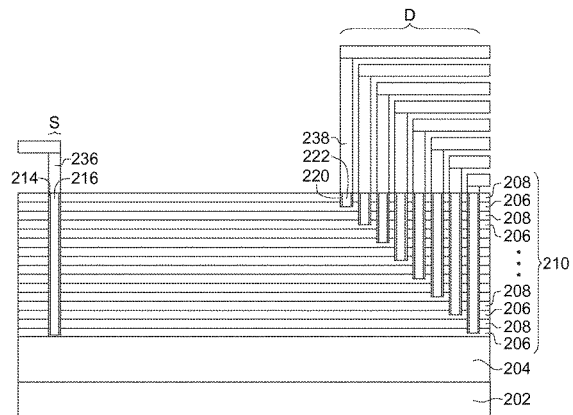
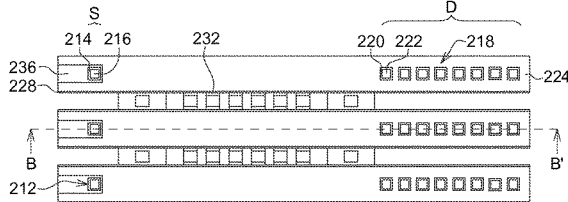

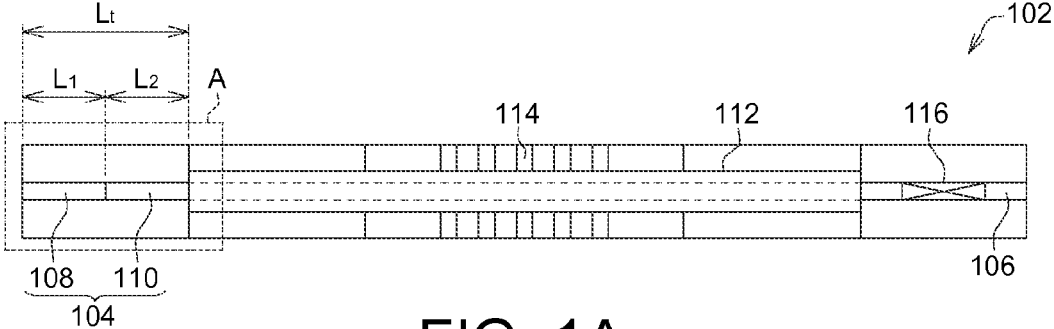

FIG. 1A

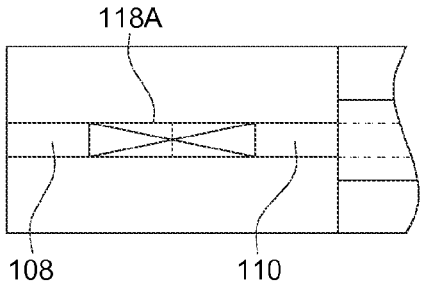

FIG. 1B

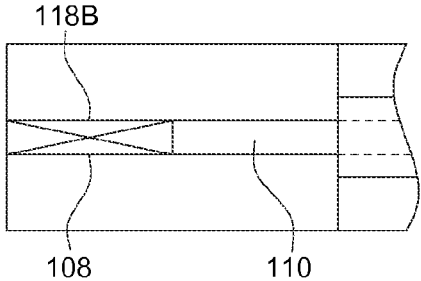

FIG. 1C

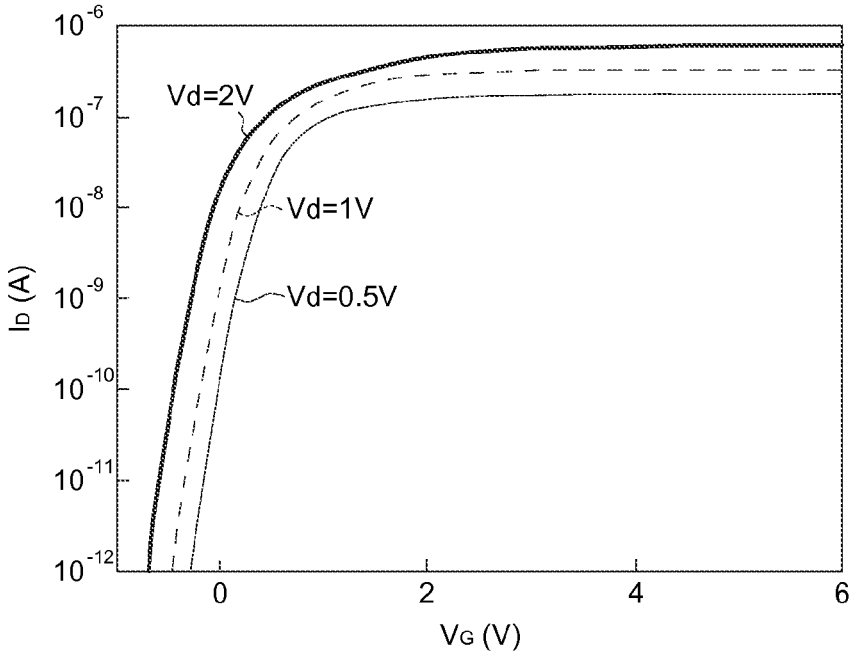

FIG. 2A

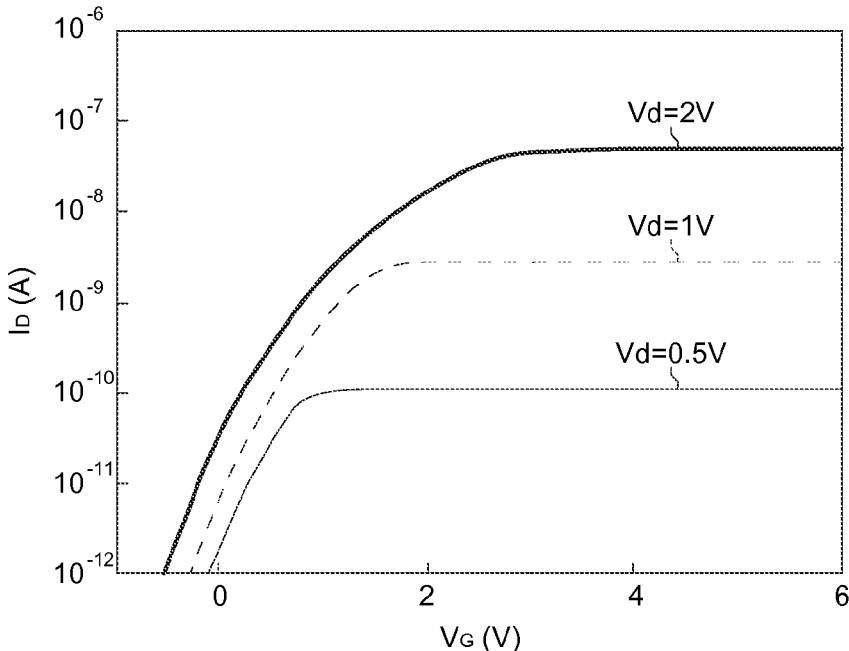

FIG. 2B

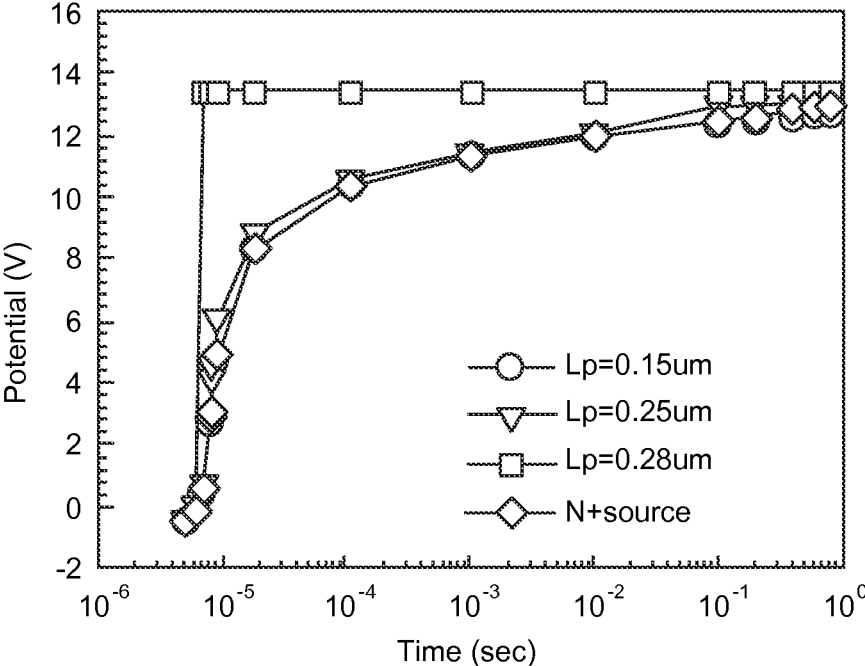

FIG. 3

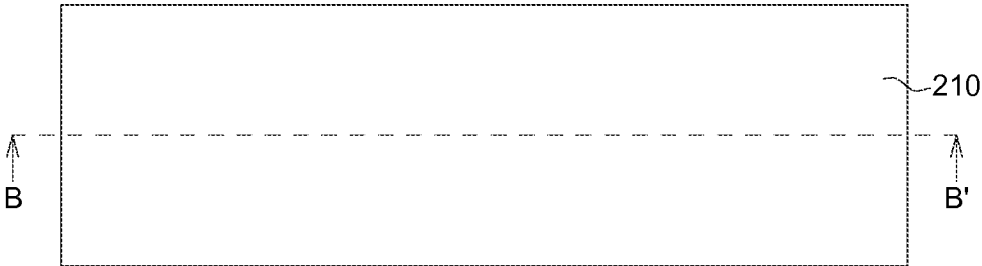

FIG. 4A



FIG. 4B

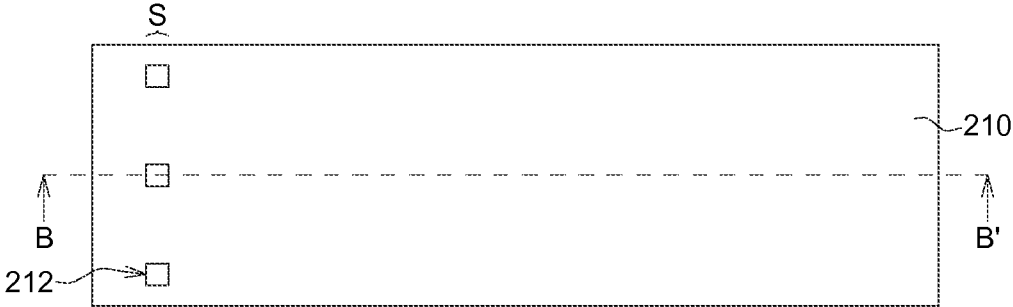

FIG. 5A

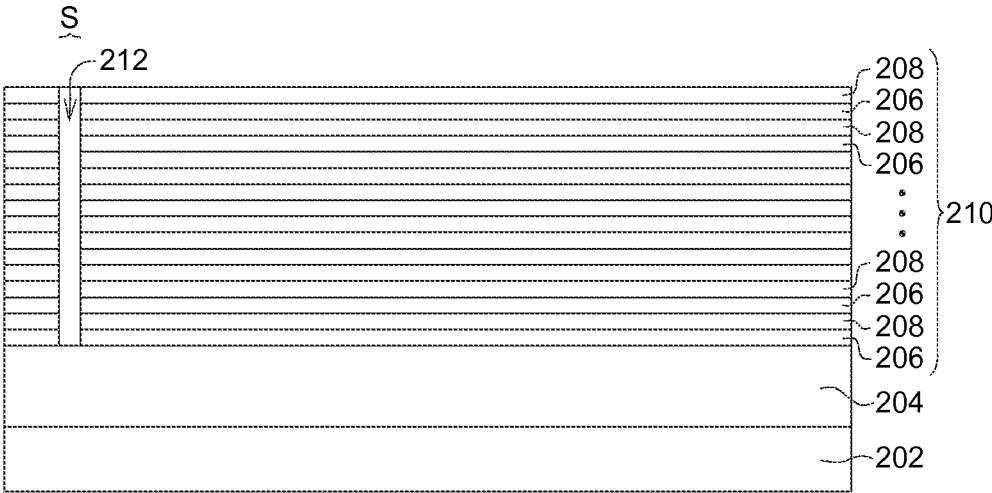

FIG. 5B

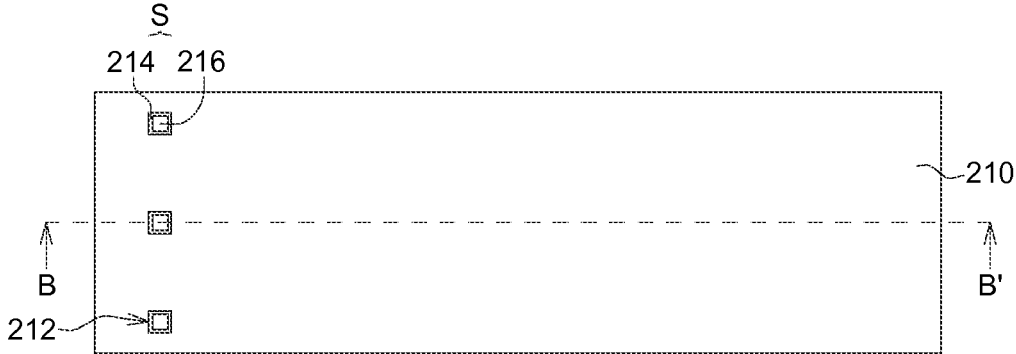

FIG. 6A

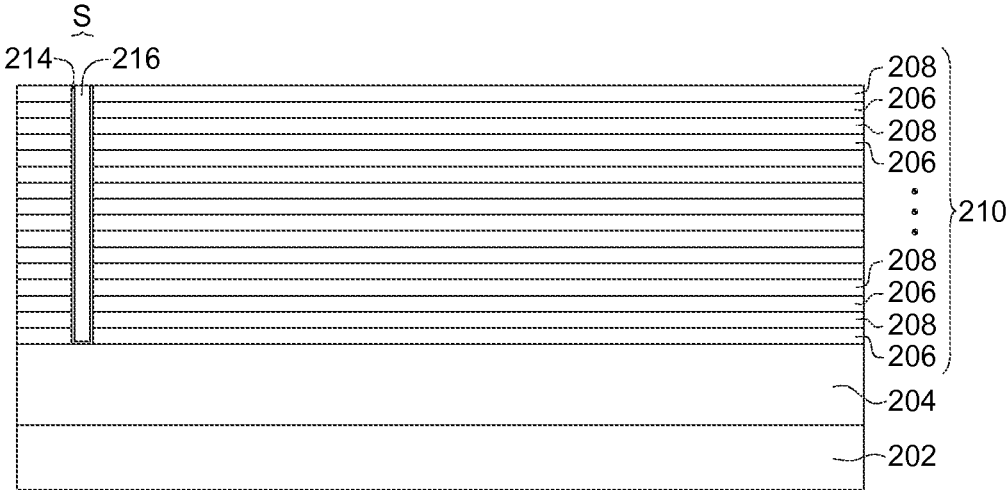

FIG. 6B

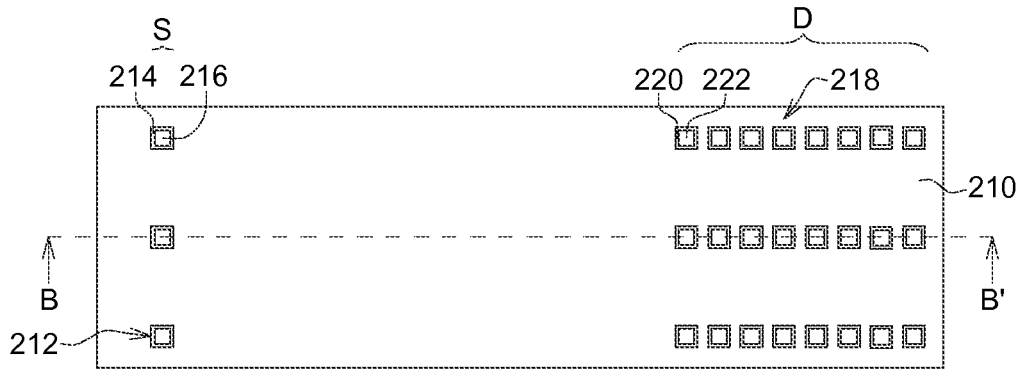

FIG. 7A

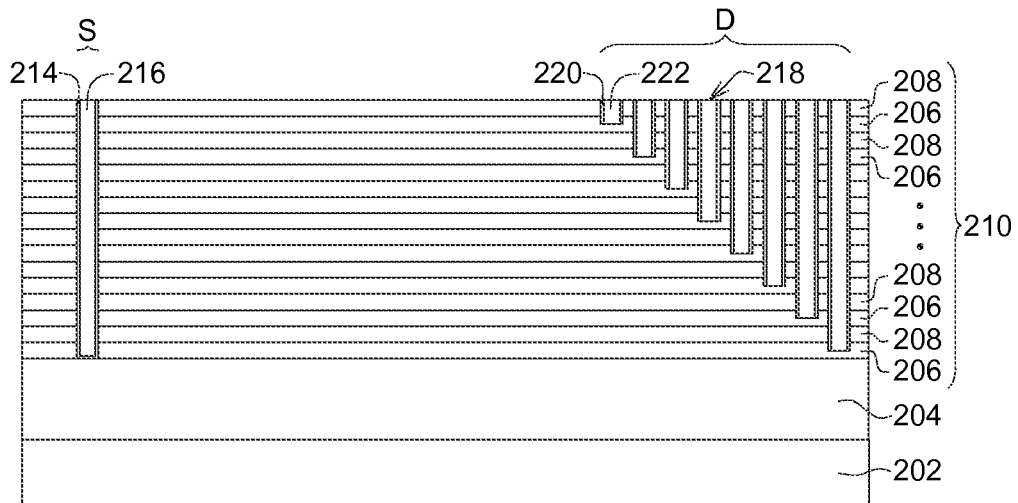

FIG. 7B

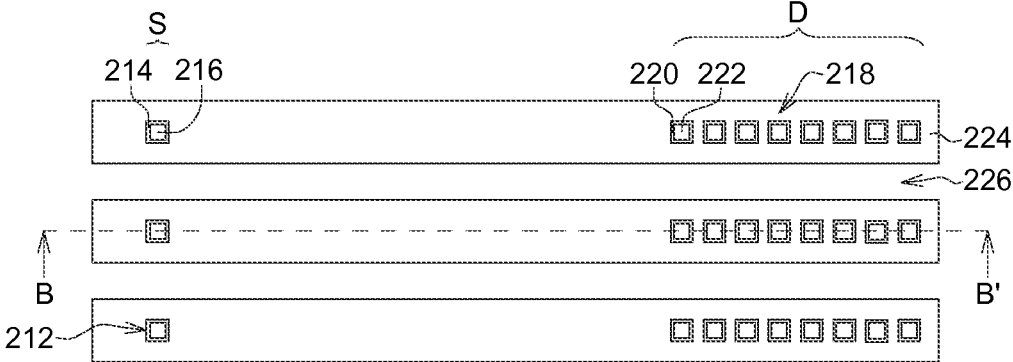

FIG. 8A

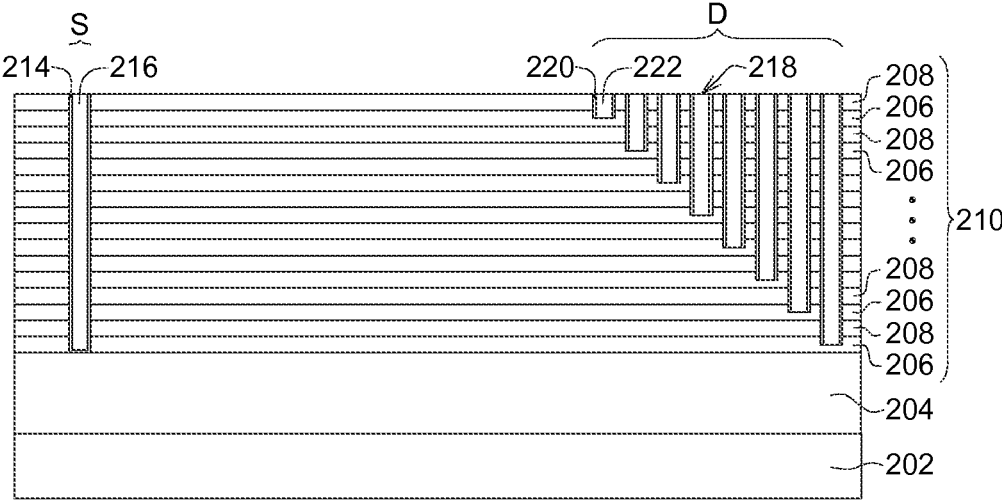

FIG. 8B

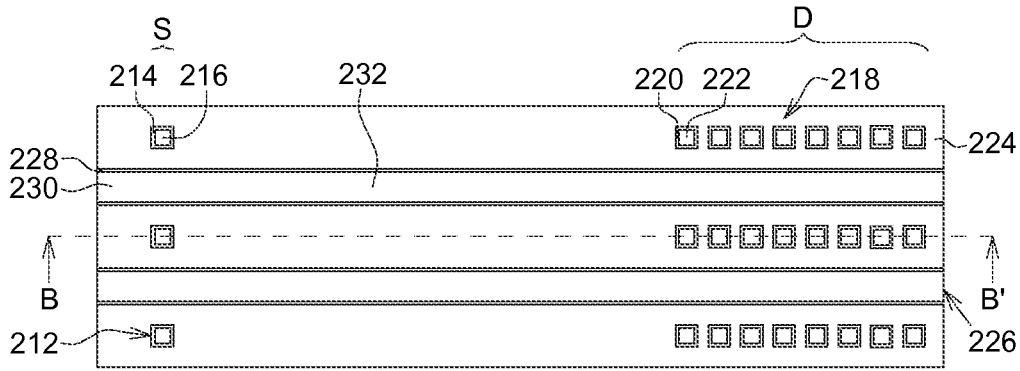

FIG. 9A

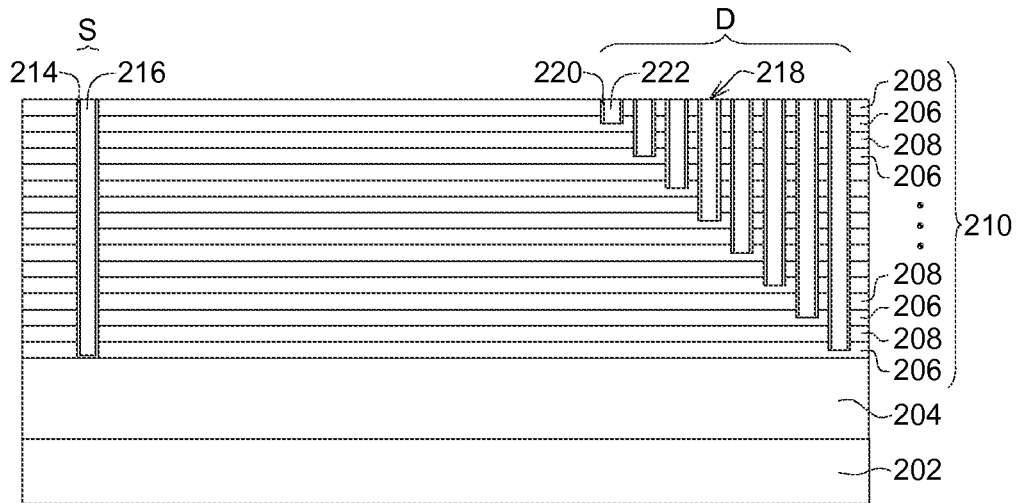

FIG. 9B

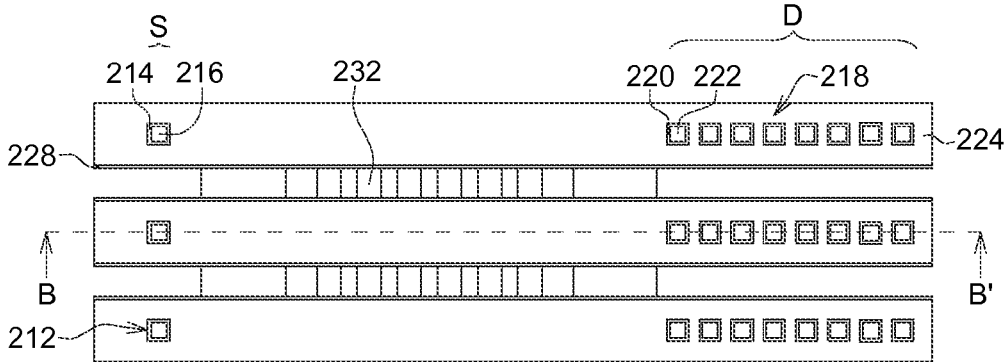

FIG. 10A

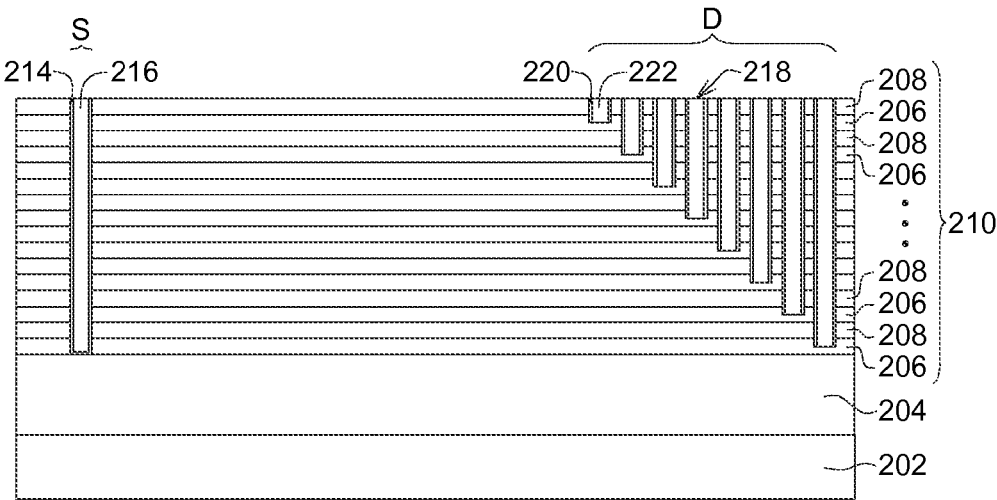

FIG. 10B

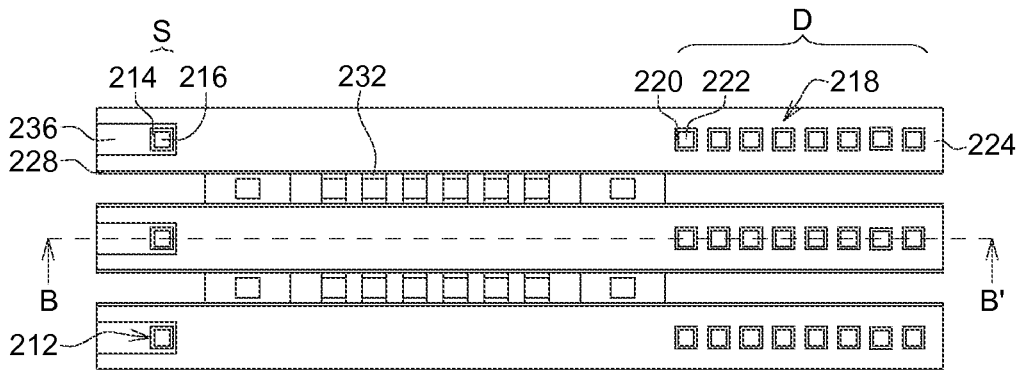

FIG. 11A

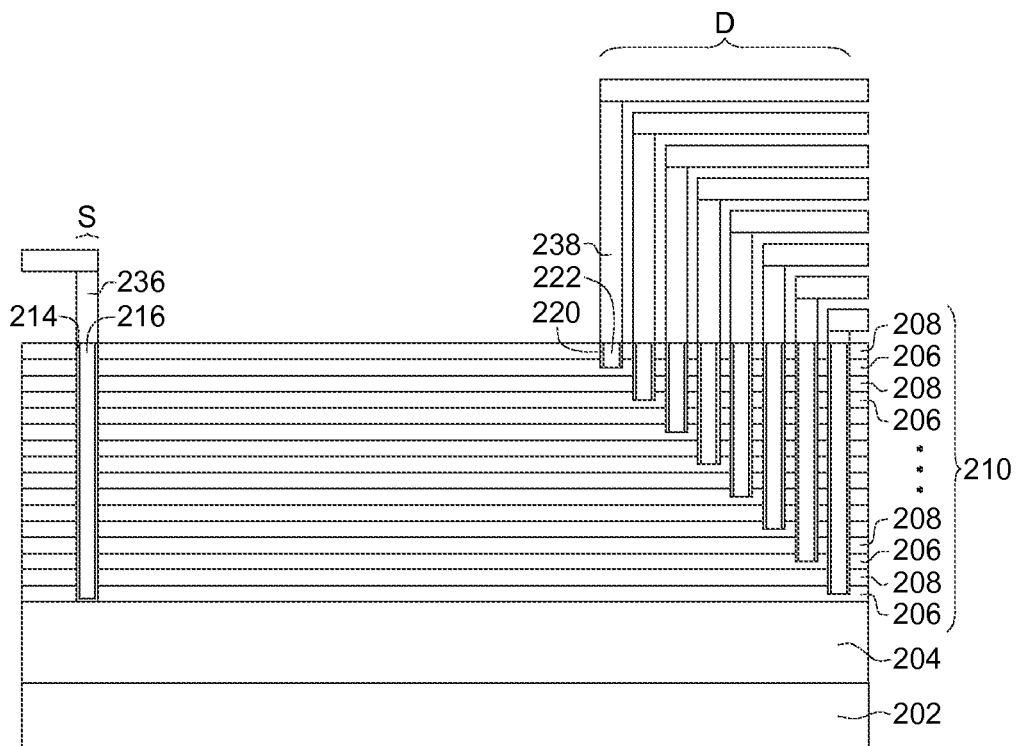

FIG. 11B

1

THREE-DIMENSIONAL MEMORY AND METHOD FOR MANUFACTURING THE SAME

TECHNICAL FIELD

The disclosure relates in general to a memory and a method for manufacturing the same, more particularly to a three-dimensional (3D) memory and a method for manufacturing the same.

BACKGROUND

A typical thin-film transistor may be erased by providing holes to boost channel potential. In a conventional planar structure, the substrate can play the role of providing holes. In contrast, in a 3D structure, such as a 3D NAND flash memory, a thin-film transistor may not contact the substrate directly, and thus it is not easy to obtain holes from the substrate. One method to provide holes to such a thin-film transistor is inducing holes by gate-induced drain leakage (GIDL). However, it is sensitive to local electric field and needs a long time to provide sufficient amount of holes. Besides, GIDL stress may damage the gate oxide and degrades the reliability. Another method is using a p-type source instead of a n-type source. However, when the thin-film transistor using a p-type source is read, a voltage drop is occurred.

SUMMARY

In this disclosure, a new structure is provided to solve the above problems. A method for manufacturing the same is also provided.

According to one embodiment, a 3D memory is provided. The 3D memory comprises a thin-film transistor. The thin-film transistor has a source region and a drain region disposed separately. The source region comprises a first source region and a second source region disposed between the first source region and the drain region. The first source region is p-type of doping, the second source region is n-type of doping, and the drain region is n-type of doping.

According to another embodiment, a method for manufacturing a 3D memory is provided. The method comprises the following steps. First, a stack of alternating conductive layers and insulating layers is formed on a substrate. A source region of a thin-film transistor of the 3D memory is formed. This step comprises: forming a through hole through the stack; forming a n-type doping layer on side-walls of the through hole; and filling a p-type doping material into the through hole on the n-type doping layer. A drain region of the thin-film transistor separated from the source region is formed. This step comprises: forming a sequence of through holes respectively connecting the conductive layers of the stack; and filling a n-type doping material into the sequence of through holes.

BRIEF DESCRIPTION OF THE DRAWINGS

FIGS. 1A-1C illustrate a part of a 3D memory according to one embodiment.

FIGS. 2A-2B show characteristics of an example according to one embodiment and a comparative example.

FIG. 3 shows characteristics of an example according to one embodiment and comparative examples.

FIGS. 4A-11B illustrate a method for manufacturing a 3D memory according to one embodiment.

2

In the following detailed description, for purposes of explanation, numerous specific details are set forth in order to provide a thorough understanding of the disclosed embodiments. It will be apparent, however, that one or more embodiments may be practiced without these specific details. In other instances, well-known structures and devices are schematically shown in order to simplify the drawing.

DETAILED DESCRIPTION

Referring to FIGS. 1A-1C, a part of a 3D memory according to one embodiment is illustrated, wherein FIGS. 1B and 1C shows the enlarged views of the region A in FIG. 1A. The 3D memory comprises a thin-film transistor **102**. For easiness of illustration, the 3D memory shown in the figures is a 3D NAND flash memory, and the thin-film transistor **102** may be provided for a memory cell as a cell transistor. However, the present invention may be adapted to other kinds of 3D memory comprising a thin-film transistor, and to thin-film transistors of other usage.

The thin-film transistor **102** has a source region **104** and a drain region **106** disposed separately. The source region **104** comprises a first source region **108** and a second source region **110** disposed between the first source region **108** and the drain region **106**. A length of the first source region **108** is L_1 , a length of the second source region **110** is L_2 , and a total length of the source region **104** is L_s . In one example, L_s equals to $0.3\ \mu\text{m}$. The first source region **108** is p-type of doping, the second source region **110** is n-type of doping, and the drain region **106** is n-type of doping.

Since the source region **104** comprises a p-type first source region **108**, a stable and fast hole source is provided. Unlike the case using only a p-type source, the source region **104** also comprises a n-type second source region **110**. As such, a voltage drop will not occur when read the thin-film transistor **102** according to the embodiment. Further, the disadvantages of using GIDL-induced holes, such as unstable, time-consuming, structure damage, etc., can be avoided.

The 3D memory may further comprise a source contact and a drain contact **116**. In one embodiment, as shown in FIG. 1B, the source contact **118A** connects both the first source region **108** and the second source region **110**. In another embodiment, as shown in FIG. 1C, the source contact **118B** connects the first source region **108** only, and does not connect the second source region **110**. In both embodiments, the length L_2 of the second source region **110** may be equal to or lower than $0.02\ \mu\text{m}$. The drain contact **116** connects the drain region **106**.

The 3D memory may further comprise a substrate (as shown in FIG. 4B), a bit line **112** disposed on the substrate, and a word line **114** disposed on the substrate and orthogonal to the bit line **112**. The source region **104** and the drain region **106** may be disposed along the bit line **112** and not contact the substrate directly.

FIGS. 2A-2B show characteristics of an example according to one embodiment and a comparative example thereof when the thin-film transistors of the example and the comparative example are read. For the example shown in FIG. 2A, the source contact **118A** connects both the p-type first source region **108** and the n-type second source region **110**. For the comparative example shown in FIG. 2B, the source contact **118B** connects only the p-type first source region **108**. For both the example shown in FIG. 2A and the comparative example shown in FIG. 2B, L_s equals to $0.3\ \mu\text{m}$, and L_1 and L_2 equal to $0.15\ \mu\text{m}$. In the comparative example,

because the p-n junction between the first source region **108** and the second source region **110** is reverse-biased during reading, I_D current is predominated by band-to-band tunneling and strongly depends on Vd bias. While in the example in which the source contact **118A** also connects the n-type source region, the I_D - V_G curves exhibit the typical behavior of n-channel reading.

FIG. 3 shows characteristics of an example according to one embodiment and comparative examples thereof when the thin-film transistors of the example and the comparative examples are erased. For all of the example and the comparative examples, L_x equals to 0.3 μm . When the n-type second source region **110** is short enough, such as equal to or lower than 0.02 μm , the hole provided from the p-type first source region **108** can more easily and rapidly pass through the second source region **110**. As such, the erase speed is further improved. According to one embodiment, the source contact may connect both the p-type first source region **108** and the n-type second source region **110**. According to an alternative embodiment, the source contact may connect only the p-type first source region **108**.

Now referring to FIGS. 4A-11B, a method for manufacturing a 3D memory according to one embodiment is illustrated, wherein the figures indicated by "B" shows cross-sectional views taken along the line B-B' in the corresponding figures indicated by "A". First, as shown in FIGS. 4A and 4B, a substrate **202** is provided, and a stack **210** of alternating conductive layers **206** and insulating layers **208** is formed on the substrate **202**. In one embodiment, a buried layer **204** may be formed between the substrate **202** and the stack **210**.

A source region S of a thin-film transistor of the 3D memory is formed, as shown in FIGS. 5A-6B. Referring to FIGS. 5A and 5B, a through hole **212** is formed through the stack **210**. Referring to FIGS. 6A and 6B, a n-type doping layer **214** is formed on sidewalls of the through hole **212**, and a p-type doping material **216** is filled into the through hole **212** on the n-type doping layer **214**. In one embodiment, the thickness of the n-type doping layer **214** may be equal to or lower than 0.02 μm .

A drain region D of the thin-film transistor is formed, as shown in FIGS. 7A-7B. The drain region D is separated from the source region S. A sequence of through holes **218** are formed respectively connecting the conductive layers **206** of the stack **210**. An insulating layer **220** may be formed on sidewalls of the through holes **218**. Then, unnecessary material is removed by etching, and a n-type doping material **222** is filled into the sequence of through holes **218**.

Bit lines **224** and word lines **232** are formed, as shown in FIGS. 8A-10B. Referring to FIGS. 8A and 8B, the stack **210** is patterned to form a plurality of bit lines **224** separated by trenches **226**. Referring to FIGS. 9A and 9B, an oxide-nitride-oxide (ONO) structure **228** is formed on sidewalls of the trenches **226** between the bit lines **224**, and a conductive material **230**, such as poly-silicon, is filled into the trenches **226**. Referring to FIGS. 10A and 10B, a plurality of word lines **232** is formed by patterning the conductive material **230**.

The sequence of forming the source region S, the drain region D, and the bit lines **224** and word lines **232** may be exchanged. Then, referring to FIGS. 11A and 11B, a source contact **236** and a plurality of drain contacts **238** are formed. In one embodiment, the source contact **236** connects both the p-type doping material **216** and the n-type doping layer **214**. In an alternative embodiment, the source contact **236**

connects the p-type doping material **216** and does not connect the n-type doping layer **214**. The drain contacts **238** connect the n-type doping material **222** in the sequence of through holes **218**.

According to the method described above, the 3D memory according to the embodiments, in which a stable and fast hole source is provided, can be easily fabricated. However, this method is provided only for explanation, and other methods to manufacture a 3D memory according to the embodiments may be carried out.

It will be apparent to those skilled in the art that various modifications and variations can be made to the disclosed embodiments. It is intended that the specification and examples be considered as exemplary only, with a true scope of the disclosure being indicated by the following claims and their equivalents.

What is claimed is:

1. A three-dimensional (3D) memory, comprising:
 - a thin-film transistor having a source region and a drain region disposed separately, wherein each of the source region and the drain region penetrates through at least a part of a stack, wherein the source region comprises a first source region and a second source region disposed between the first source region and the drain region, and wherein the first source region is p-type of doping, the second source region is n-type of doping, and the drain region is n-type of doping;
 - wherein the stack is formed of alternating conductive layers and insulating layers, a through hole is formed through the stack, a n-type doping layer is formed on sidewalls of the through hole, and a p-type doping material is filled into the through hole on the n-type doping layer, wherein the n-type doping layer forms the second source region, and the p-type doping material forms the first source region.
2. The 3D memory according to claim 1, further comprising:
 - a source contact connecting both the first source region and the second source region; and
 - a drain contact connecting the drain region.
3. The 3D memory according to claim 1, further comprising:
 - a source contact connecting the first source region and not connecting the second source region; and
 - a drain contact connecting the drain region.
4. The 3D memory according to claim 3, wherein a length of the second source region is equal to or lower than 0.02 μm .
5. The 3D memory according to claim 1, wherein a length of the second source region is equal to or lower than 0.02 μm .
6. The 3D memory according to claim 1, wherein the thin-film transistor is provided for a memory cell.
7. The 3D memory according to claim 1, further comprising:
 - a substrate; and
 - the stack of bit lines disposed on the substrate; wherein the source region and the drain region are disposed along the bit lines and do not contact the substrate directly.
8. The 3D memory according to claim 7, further comprising:
 - a word line disposed on the substrate and orthogonal to the bit lines.