

(No Model.)

C. P. MACK.
HYDROCARBON BURNER.

No. 548,647.

Patented Oct. 29, 1895.

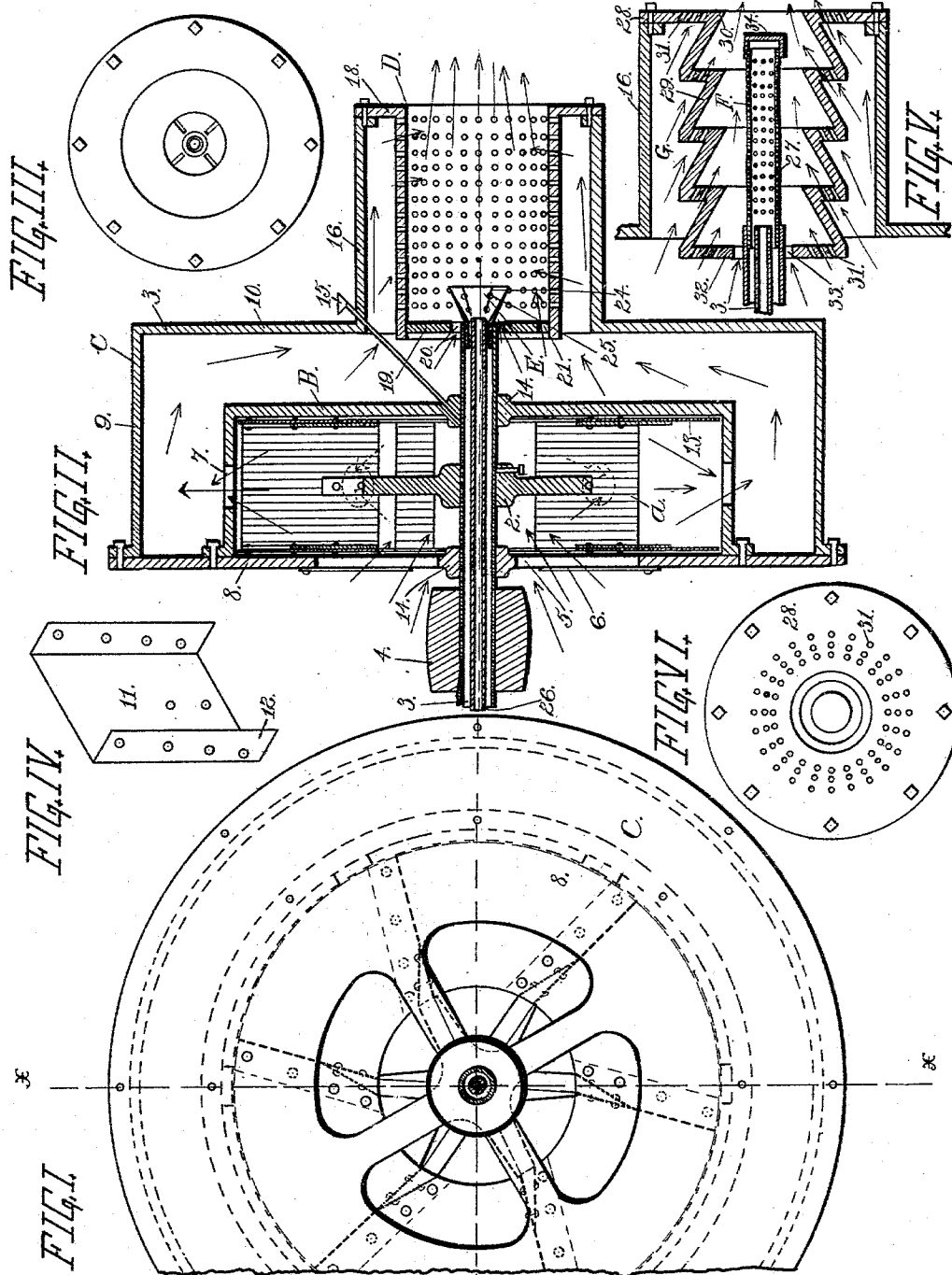

WITNESSES
W. C. Swift.
W. H. Bradbury.

INVENTOR
Courtland P. Mack,
BY *J. M. [unclear]*
ATTORNEY.

UNITED STATES PATENT OFFICE

COURTLAND P. MACK, OF MINNEAPOLIS, ASSIGNOR OF NINE-TWENTIETHS
TO EDWARD W. DURANT, JR., OF STILLWATER, MINNESOTA.

HYDROCARBON-BURNER.

SPECIFICATION forming part of Letters Patent No. 548,647, dated October 29, 1895.

Application filed December 16, 1893. Serial No. 493,855. (No model.)

To all whom it may concern:

Be it known that I, COURTLAND P. MACK, of Minneapolis, Hennepin county, Minnesota, have invented certain Improvements in Hydrocarbon-Burners, of which the following is a specification.

My invention relates to improvements in hydrocarbon-burners, its object being to provide improved means for atomizing the oil and mingling it with the air, and for consuming the intermixed oil and air.

To this end my invention consists in providing a fan mounted upon a hollow shaft, through the opening in which shaft extends a pipe leading from the source of oil-supply. The fan is driven by any suitable power, and is inclosed in a case having valve-controlled air-inlets around the shaft in the end opposite the burner and peripheral outlet-openings. Surrounding the fan-case is a still larger inclosing-case with an intervening space between it and the periphery of the fan-case and the end of the fan-case toward the burner. Centrally secured to this outer case and concentric therewith is the burner, which consists of a perforate cylinder or tube having an axial opening at the inner end around the hollow shaft of the fan, the outer end being entirely open. Surrounding this burner cylinder or tube is a concentric cylinder closed at its outer end by a flange upon the burner-tube and open at the other end to the interior of the outer case. Secured to the end of the fan-shaft is a centrifugal sprayer or atomizer into which the oil-pipe enters. This atomizer may be of different forms, either funnel-shaped with slotted and perforate walls or a perforate cylinder. The walls of the burner-tube may also be circumferentially corrugated, with perforations through the sides of the corrugations inclined toward the outer end of the burner, so as to allow the air to pass from the same diagonally through the atomizer.

My invention further consists in the construction and combination hereinafter more particularly described and claimed.

In the accompanying drawings, forming part of this specification, Figure I is a partial end elevation of my invention, looking toward the end of the fan-case opposite the burner.

Fig. II is a central longitudinal section of the same on line xx of Fig. I, showing the relative positions of the parts and having a funnel-shaped oil-atomizer and a cylindrical burner-tube. Fig. III is an end elevation of the burner. Fig. IV is a perspective view of one of the fan blades or wings. Fig. V is a central longitudinal section of a modified form of burner-tube and oil-atomizer, and Fig. VI is an end elevation of the same.

In the drawings, the fan A is shown secured to the hub 2, which is mounted upon the hollow shaft 3, provided with the driving-pulley 4. Inclosing the fan is the case B, through one end of which are the centrally-arranged inlet-openings 5, provided with valves 6 for regulating the size of the openings. The case B is also provided with peripheral outlet-openings 7.

Surrounding the case B is the case C, having the head 8 in common with the fan-case, and its cylindrical wall 9 and head 10 parallel with but at a little distance from the corresponding walls of the fan-case, thus allowing a free passage for the air emitted through the openings 7.

The blades or wings 11 of the fan are formed, preferably, with flanges 12, by means of which they are riveted to the ends or rings 13 of the fan. The case B is also provided with suitable bearings 14 for the hollow shaft, which are lubricated in any suitable manner, as by means of an oil-pipe 15. Centrally arranged upon the head 10 of the case C is the cylinder 16, concentric with the case, the inner end of which is open. Coaxially arranged within the cylinder 16 is the burner tube or cylinder D, the outer end of which has a circumferential flange 18, which serves to close the annular space between it and the cylinder 16.

The inner end of the burner-tube is partially closed by means of the head 19, which has a central opening 20 around the shaft 3, and also preferably a segmental opening 21 at the lower side of the tube, as shown in Fig. II. This burner-tube is provided with a series of perforations 22 for the admission of air from the surrounding space in the tube 16. The end of the shaft 3 extends through and is approximately flush with the inner face of the head 19 of the burner-tube and has se-

cured to it the atomizer E, preferably conical in shape, with the larger end outward, and provided with radiating slots 24 and perforations 25. Extending through the opening in the shaft and into the atomizer E is the oil-pipe 26, leading to a source of oil-supply.

In the modified construction shown in Figs. V and VI the shaft 3 is provided with the cylindrical sprayer F, provided with a series of perforations 27 and preferably having a cap 34 closing its outer end. For use in connection with this modified form of atomizer I prefer to use the form of burner-tube G, having peripheral flanges 28 at its outer end secured to the end of the cylinder 16 in the same manner as in the other construction, and having its side walls corrugated, preferably in the form of a series of similar cones 29, with annular interior heads or flanges 30 in the larger ends of the cones closing the space between the cones. Through these heads 30 as well as through the flange 28 are arranged diagonal perforations 31. The head 32 at the inner end of the tube has a central opening 33 and perforations 31.

Operation: The fan being set in motion by means of any suitable power and the oil allowed to flow through its pipe 26 as the oil is discharged into the atomizer E, its rotary motion carries the oil toward its outer edge and through the slits and perforations in its side walls, throwing the oil off in fine particles. At the same time the outer air is drawn into the fan through the openings 5 and forced out through the outlet-openings 7, thence being driven around over the closed head of the fan-case through the opening around the atomizer and into the cylinder 16 around the burner-tube, thence through the perforations 22, where it meets and is mingled with the oil as sprayed from the atomizer 3, the combined air and oil being then in condition for ignition, the flame filling the burner-tube and projecting outward therefrom. The force of the air-blast is regulated by the speed of the fan and the size of the valve-controlled openings 5.

In the modified construction shown in Fig. V the oil is sprayed by centrifugal force through the openings in the side walls of the atomizer, and the air from the fan plunges through the openings 31 diagonally toward the atomizer the combustion taking place within and beyond the tube G in the same manner as with the other construction.

I claim—

1. In a hydro-carbon burner, the combination of the perforate burner tube, the centrifugal oil atomizer arranged within said tube, and means for forcing air through the perforations of the tube, substantially as described.

2. In a hydro-carbon burner, the combination of the perforate open end burner tube, the included centrifugal atomizer, the head in the inner end of the tube having openings adjacent the atomizer, the fan, and the case inclosing the fan and burner tube with intermediate space serving as a communicat-

ing passage from the fan to the perforations in the sides and the openings in the head of said tube.

3. The combination with the fan and the centrifugal oil atomizer, of the burner tube inclosing the atomizer having its side walls circumferentially corrugated and perforated in the direction of the blast, means for conveying oil to said atomizer, and means for conducting air from said fan to the perforations in said tube.

4. The combination with the fan, of the centrifugal oil atomizer, the inclosing burner tube having its side walls perforated, an annular opening surrounding the atomizer, and a segmental opening at its bottom underneath the atomizer, means for conveying oil to said atomizer and means for conducting air from the fan to said openings and perforations, substantially as described.

5. The combination of the burner tube having an open outer end and perforations in its side walls inclined toward said outer end, the inclosing case for said tube communicating with a source of compressed air supply and having axially inclined end openings, and means for conveying oil into said tube.

6. The combination with the perforate burner tube and its included centrifugal burner, of the co-axially arranged fan having axial air inlets and peripheral outlets, and means for conducting the air from said outlets to the perforations of said tube.

7. In a hydro-carbon burner, the combination of the perforate centrifugal atomizer, the perforate inclosing burner tube, and means for forcing air through the perforations into said tube.

8. In a hydro-carbon burner, the combination with the burner tube having perforate side walls and an open outer end, of a centrifugal oil atomizer arranged co-axially within said tube, the head closing the inner end of the tube, but having a narrow central opening around the atomizer, means for rotating said atomizer, and means for forcing the air through the opening around the same, and through the perforations in the walls of said tube, substantially as described.

9. In a hydro-carbon burner, the combination of the burner tube having perforate side walls and an open outer end, the head substantially closing the inner end of the tube, and having a central opening, the fan, its hollow shaft arranged co-axially within said tube, and with its end extending through the opening in its head but with an annular space around it, the centrifugal oil atomizer arranged within said tube and secured to said shaft, and the oil pipe arranged within said hollow shaft and leading to said atomizer, substantially as described.

10. In a hydro-carbon burner, the combination of the fan mounted upon a hollow shaft, the fan case having centrally arranged air inlets in one head and peripheral outlets, the outer inclosing case, with a space between its

side walls and head adjacent to the closed head of the fan case, the axial opening through said head of the outer case, the cylinder secured to said head of the outer case and registering with said opening, the perforate burner tube co-axially arranged within said cylinder with an air space between it and said cylinder, the centrifugal oil atomizer, carried by said shaft and arranged within said burner tube, substantially as described.

11. In a hydro-carbon burner, the combination with the perforate burner tube, of the cylinder inclosing said tube, the fan, its hollow shaft having its end projecting into said burner tube, the centrifugal oil atomizer carried by said shaft, and arranged within said tube, and means for directing the air blast from said fan toward the fan shaft, and into

the inner end, and through the side walls of said burner tube, substantially as described. 20

12. The combination of the perforate burner tube, the included centrifugal atomizer, the co-axially arranged fan having axial air inlet and peripheral outlets, and the conduit connecting said fan with said tube. 25

13. In combination a perforate open end burner tube, a centrifugal atomizer arranged within the tube, an oil conduit leading to said atomizer and the air blast conduit leading to said tube. 30

In testimony whereof I have hereunto set my hand this 28th day of November, 1893.

COURTLAND P. MACK.

Witnesses:

T. D. MERWIN,
H. S. JOHNSON.