

(19) World Intellectual Property Organization
International Bureau



(43) International Publication Date
26 May 2006 (26.05.2006)

PCT

(10) International Publication Number
WO 2006/055666 A1

- (51) International Patent Classification:
A61B 8/00 (2006.01) B21F 41/00 (2006.01)
H04R 17/00 (2006.01) A61B 8/14 (2006.01)
- (21) International Application Number:
PCT/US2005/041597
- (22) International Filing Date:
15 November 2005 (15.11.2005)
- (25) Filing Language: English
- (26) Publication Language: English
- (30) Priority Data:
10/990,794 17 November 2004 (17.11.2004) US
- (71) Applicant (for all designated States except US):
SALUTRON, INC. [US/US]; 40979 Encyclopedia
Circle, Fremont, CA 94538 (US).
- (72) Inventors; and
- (75) Inventors/Applicants (for US only): LO, Thomas, Ying-
Ching [US/US]; 820 Optimo Avenue, Fremont, Ca 94539
(US). CHANG, Rong, Jong [US/US]; 619 Fontes Drive,
Fremont, CA 94539 (US).
- (74) Agent: BACHMANN, Stephen, R.; Vierra Magen Mar-
cus Harmon & DeNiro, LLP, 685 Market Street, Suite 540,
San Francisco, CA 94105 (US).

- (81) Designated States (unless otherwise indicated, for every
kind of national protection available): AE, AG, AL, AM,
AT, AU, AZ, BA, BB, BG, BR, BW, BY, BZ, CA, CH, CN,
CO, CR, CU, CZ, DE, DK, DM, DZ, EC, EE, EG, ES, FI,
GB, GD, GE, GH, GM, HR, HU, ID, IL, IN, IS, JP, KE,
KG, KM, KN, KP, KR, KZ, LC, LK, LR, LS, LT, LU, LV,
LY, MA, MD, MG, MK, MN, MW, MX, MZ, NA, NG, NI,
NO, NZ, OM, PG, PH, PL, PT, RO, RU, SC, SD, SE, SG,
SK, SL, SM, SY, TJ, TM, TN, TR, TT, TZ, UA, UG, US,
UZ, VC, VN, YU, ZA, ZM, ZW.
- (84) Designated States (unless otherwise indicated, for every
kind of regional protection available): ARIPO (BW, GH,
GM, KE, LS, MW, MZ, NA, SD, SL, SZ, TZ, UG, ZM,
ZW), Eurasian (AM, AZ, BY, KG, KZ, MD, RU, TJ, TM),
European (AT, BE, BG, CH, CY, CZ, DE, DK, EE, ES, FI,
FR, GB, GR, HU, IE, IS, IT, LT, LU, LV, MC, NL, PL, PT,
RO, SE, SI, SK, TR), OAPI (BF, BJ, CF, CG, CI, CM, GA,
GN, GQ, GW, ML, MR, NE, SN, TD, TG).

Published:
— with international search report
— before the expiration of the time limit for amending the
claims and to be republished in the event of receipt of
amendments

For two-letter codes and other abbreviations, refer to the "Guid-
ance Notes on Codes and Abbreviations" appearing at the begin-
ning of each regular issue of the PCT Gazette.

(54) Title: ULTRASONIC MONITOR FOR MEASURING BLOOD FLOW AND PULSE RATES

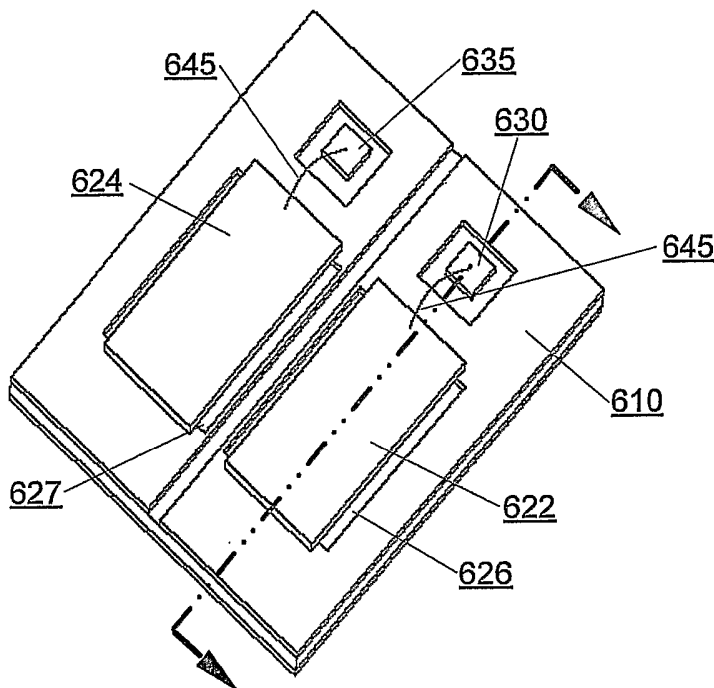

(57) Abstract: An ultrasonic monitor (600) implemented on a PCB includes a gel pad (240) comprised of a gel layer and a membrane layer. Ultrasonic signals are transmitted between the ultrasonic monitor (600) and a living subject through the gel pad. An air gap (626, 627) is formed in the PCB underneath transducer elements to provide for more efficient signal transmission. These features provide for a low power, low cost, more efficient ultrasonic monitor. The entire ultrasonic monitor may be encapsulated in plastic, a gel, or both to provide water resistant properties.

WO 2006/055666 A1

**ULTRASONIC MONITOR FOR MEASURING BLOOD
FLOW AND PULSE RATES**

5

CROSS REFERENCE TO RELATED INVENTION

[0001] The instant non-provisional applications is related to the following patent applications, all of which are hereby incorporated by reference in their
10 entirety:

[0002] United States patent application no. 10/346,296, filed on January 15, 2003;

15 [0003] United States patent application no. 10/758,608, filed on July 14, 2004, which in turn is a continuation-in-part of parent non-provisional patent application no. 10/346,296, filed January 15, 2003; and

[0004] United States patent application no. 10/991,115 filed the same day as
20 the present application, entitled "GEL PAD FOR USE WITH AN ULTRASONIC MONITOR", having inventors Thomas Ying-Ching Lo, Rong Jong Chang, attorney docket number SALU-01003US0.

BACKGROUND OF THE INVENTION

25

Field of the Invention

[0005] The present invention relates to ultrasonic monitors for measuring heart rates and pulse rates in living subjects.

Description of the Related Art

[0006] Measuring heart and pulse rates in living subjects has become a
5 valuable tool in physical exercise and health monitoring. A pulse rate is
measured by counting the rate of pulsation of a subject's artery. The heart rate
is measured by sensing the electrical activity of the heart based on
electrocardiograms (for example EKG or ECG). Individuals who want to
increase their endurance or performance may wish to exercise while
10 maintaining target heart rates. Conversely, subjects with a history of heart
disease or other heart related condition should avoid exceeding a certain heart or
pulse rate to reduce unnecessary strain on their heart.

[0007] The heart rate and pulse rate of a subject are related. Heart rate may
15 be defined as the number of heart contractions over a specific time period,
usually defined in beats per minute. A pulse is defined as the rhythmical
dilation of a vessel produced by the increased volume of blood forced through
the vessel by the contraction of the heart. Since heart contractions normally
produce a volume of blood that can be measured as a pulse, heart rate and pulse
20 rate are ideally the same. However, a pulse rate may differ from the heart rate
during irregular heart beats or premature heart beats. In this case, a heart
contraction may not force enough blood through a blood vessel to be measured
as a pulse.

[0008] Most subjects that require continuous heart rate readings choose a
25 monitor that requires a chest strap. Though they provide heart rates
continuously, chest straps are cumbersome and generally undesirable to wear.
In addition to chest strap solutions, portable patient monitors (e.g., vital signs
monitors, fetal monitors) can perform measuring functions on subjects such as
arrhythmia analysis, drug dose calculation, ECG waveforms cascades, and
30 others. However, such monitors are usually fairly large and are attached to the

subject through uncomfortable wires.

[0009] The shallow depth of the radial artery in the wrist offers a number of advantages for achieving continuous pulse detection at the wrist. Prior sensors that monitor pressure pulses in the wrist have not been effective. Pressure pulses are attenuated by the tissues between the artery and the sensor. Most of the high frequency signal components are lost because of the attenuation. Additionally, muscle movement may create substantial noise at the pressure sensors. The low frequency noise signals make it very difficult to reliably identify low frequency blood pressure pulses.

10

[0010] Ultrasonic monitors using sonar technology were developed to overcome noise signal problems. Ultrasonic monitors transmit ultrasonic energy as a pulse signal. When a power source drives a transducer element, such as a piezoelectric crystal, to generate the pulse signal, the ultrasonic pulse signal is generated in all directions, including the direction of the object to be measured such as a blood vessel. The portion of the ultrasonic pulse signal reaching the vessel is then reflected by the vessel. When the blood vessel experiences movement, such as an expansion due to blood flow from a heart contraction, the reflected pulse signal experiences a frequency shift, also known as the Doppler shift.

20

[0011] When either the source of an ultrasonic signal or the observer of the radar signal is in motion, an apparent shift in frequency will result. This is known as the Doppler effect. If R is the distance from the ultrasonic monitor to the blood vessel, the total number of wavelengths λ contained in the two-way path between the ultrasonic monitor and the target is $2R/\lambda$. The distance R and the wavelength λ are assumed to be measured in the same units. Since one wavelength corresponds to an angular excursion of 2π radians, the total angular excursion Φ made by the electromagnetic wave during its transit to and from the blood vessel is $4\pi R/\lambda$ radians. When the blood vessel experiences movement, R

25
30

and the phase Φ are continually changing. A change in Φ with respect to time is equal to a frequency. This is the Doppler angular frequency W_d , given by

$$W_d = 2\pi f_d = \frac{d\Phi}{dt} = \frac{4\pi}{\lambda} \frac{dR}{dt} = \frac{4\pi V_r}{\lambda}$$

where f_d is the Doppler frequency shift and V_r is the relative (or radial) velocity of target with respect to the ultrasonic monitor.

[0012] The amount of the frequency shift is thus related to the speed of the moving object from which the signal reflects. Thus, for heart rate monitor applications, the flow rate or flow velocity of blood through a blood vessel is related to the amount of Doppler shift in the reflected signal.

10

[0013] A piezoelectric crystal may be used both as the power generator and the signal detector. In this case, the ultrasonic energy is emitted in a pulsed mode. The reflected signal is then received by the same crystal after the output power source is turned off. The time required to receive the reflected signal depends upon the distance between the source and the object. Using a single crystal to measure heart rates requires high speed power switching due to the short distance between source and object. In addition, muscle movement generates reflections that compromise the signal-to-noise-ratio in the system. The muscle movement noise has a frequency range similar to the frequency shift detected from blood vessel wall motion. Therefore, it is very difficult to determine heart rates with this method. The advantage of this approach, however, is low cost and low power consumption.

[0014] In some ultrasonic signal systems, two piezoelectric elements are used to continuously measure a pulse. The two elements can be positioned on a base plate at an angle to the direction of the blood. In continuous pulse rate measurement, the Doppler shift due to blood flow has a higher frequency than the shifts due to muscle artifacts or tissue movement. Therefore, even if the muscle motion induced signals have larger amplitudes, they can be removed by

25

a high pass filter to retain the higher frequency blood flow signals. The disadvantages of continuous mode over pulsed mode are higher cost and more power consumption

5 **[0015]** Several wrist mounted ultrasonic monitor devices are known in the art. However, ultrasonic signals are prone to diffraction and attenuation at the interface of two media of different densities. Thus, air in the media or between the monitor and the subject's skin make ultrasonic energy transmission unreliable. Prior ultrasonic monitors require applying water or an aqueous gel
10 between the transducer module and the living subject to eliminate any air gap. Because water and aqueous gels both evaporate quickly in open air, they are not practical solutions.

[0016] United States Patent Application number 10/758,608, United State
15 Patent Publication no. 20040167409, Lo et al. disclosed the use of thermoplastic and thermoset gels as the transmission medium for ultrasonic signals to overcome the problems associated with water and aqueous gel solutions. In United States patent no. 6,716,169, Muramatsu et al. disclosed a soft contact layer based on silicone gel, a type of thermoset gel, as the medium for the
20 ultrasonic signal transmission. These gels mainly consist of a large quantity of non-evaporating (at ambient condition) liquid diluents entrapped in a lightly cross-linked elastomeric network. These cross-linked networks can be either physical in nature, such as in the thermoplastic gels, or chemical in nature, such as the thermoset gels.

25

[0017] Both gel types have deficiencies. First, the liquid diluents, though entrapped in the elastomeric network, can still diffuse into skin of a user upon contact over a longer period of time. Since silicone gels use silicone oil as diluents, diffusion of silicone gels is an important health concern. It is therefore
30 desirable to have a gel design that prevents oil diffusion into the living subject.

Second, the soft gels of these known methods are difficult to handle. Though a softer gel allows better contact with the skin and results in better ultrasonic transmission, soft gels are weak and difficult to handle. It is highly desirable to have a gel design that allows easy handling but preserves good ultrasonic
5 transmission. Third, the gels of prior art systems are known to collect dirt easily. Dirt on the surface of the gel results in a loss of contact with skin and affects the ultrasonic transmission.

[0018] Efficiency of the transmitting transducer is an important feature in
10 wrist worn and other small heart rate monitors. Transmission of an ultrasonic signal by a transmitting transducer can be made more efficient by use of a reflector. Transmission signals generated away from target can be reflected using a reflector on one or more sides of the transducer. Some heart rate
15 monitors include a foam substance having air voids underneath the piezoelectric crystals. As illustrated in FIG. 1, a foam layer 120 may be placed within ultrasonic module 110 underneath transducers 130 and 140. The foam material
20 air voids partially inhibit ultrasound energy penetration and provide fairly effective reflection of ultrasound signals. With this foam backing, some of the ultrasonic signals directed towards the foam are reflected toward the desired
25 direction. The disadvantage to incorporating foam layers is that they are manually installed during manufacture. Other prior systems increase efficiency by separating the two piezoelectric crystals by a channel on a base plate. This reduces crosstalk between the transducers to some degree but does not eliminate the loading or dampening effect caused by the base plate.

[0019] What is needed is an improved heart rate monitor that provides
continuous heart rate readings through a transmission media that minimizes the
air gap between the transducers and a living subject. The transmission media
should not dry out during the monitoring, leave an uncomfortable wet film, or
30 be prone to dirt accumulation. What is also needed is an ultrasonic monitor that

is more power efficient yet inexpensive to produce.

SUMMARY OF THE INVENTION

5 **[0020]** The present invention, roughly described, pertains to ultrasonic monitors. The ultrasonic monitor in-vitro uses ultrasonic signals to measure movement inside the body of a living subject. The movement may be a heart contraction, flowing blood or movement of the blood vessel itself. From information collected from these movements, electronics within the monitor
10 may determine blood flow rate, heart rate, or pulse rate of the living subject.

[0021] In one embodiment, the monitor is implemented on a circuit board, such as a printed circuit board (PCB). By implementation on a PCB, the monitor system can be integrated to a very small footprint. This allows for a
15 very efficient system with a much lower power requirement than prior systems. A pair of transducers is mounted directly to the PCB. This results in higher efficiency than previous implementations where the transducers were attached to some supporting structure, such as a glass base plate, thereby causing a signal
load.

20

[0022] The PCB can be used to implement an ultrasound signal reflection layer. In one embodiment, a portion of the outer layer of the PCB is removed to create an air gap portion. The air gap portion acts to reflect ultrasound signals. The transmitting transducer is mounted to the PCB over the air gap. When
25 driven, the transmitting crystal generates an ultrasound signal that travels towards the PCB in addition to the desired direction towards a target. The portion of the originally transmitted ultrasound signal traveling towards the PCB is reflected by the thin air gap away from the PCB and towards the intended target.

30

[0023] In some embodiments, a multi-layer gel pad is used to transmit ultrasonic signals between the ultrasonic monitor and the skin of the subject. The gel pad includes a gel layer adhered to a membrane layer. The membrane layer can be applied to one or more surfaces of the gel layer and prevents diluents within the gel layer from escaping. This is advantageous when the gel includes elements that are not intended to make contact with the living subject or other surfaces.

[0024] In another embodiment, the PCB can be entirely encapsulated in plastic, a water resistant gel, or a combination of the two. This provides for keeping the system of the ultrasonic monitor protected from debris such as dirt, dust and water.

[0025] The ultrasonic monitor can include circuitry composed of hardware, software, and/or a combination of both hardware and software. The circuitry demodulates the received ultrasonic signal as discussed with respect to FIGs. 3-5. The software used for the present invention is stored on one or more processor readable storage media including hard disk drives, CD-ROMs, DVDs, optical disks, floppy disks, tape drives, RAM, ROM or other suitable storage devices. In alternative embodiments, some or all of the software can be replaced by dedicated hardware including custom integrated circuits, gate arrays, FPGAs, PLDs, and special purpose computers.

BRIEF DESCRIPTION OF THE DRAWINGS

- [0026]** Figure 1 illustrates a cross section of an ultrasonic monitor of the prior art.
- 5 **[0027]** Figure 2A illustrates one embodiment of an ultrasonic monitor with a physical connection to a display device.
- [0028]** Figure 2B illustrates one embodiment of an ultrasonic monitor with a wireless connection to a display device.
- [0029]** Figure 3 illustrates one embodiment of a block diagram of an ultrasonic monitor.
- 10 **[0030]** Figure 4 illustrates one embodiment of a method of operation of an ultrasonic monitor.
- [0031]** Figure 5 illustrates one embodiment of a method for performing additional processing by an ultrasonic monitor.
- 15 **[0032]** Figure 6 illustrates one embodiment of a perspective view of an ultrasonic monitor on a PCB having an air gap.
- [0033]** Figure 7 illustrates one embodiment of a side view of an ultrasonic monitor on a PCB having an air gap.
- [0034]** Figure 8A illustrates one embodiment of a perspective view of an ultrasonic monitor on a PCB having an air gap with a supporting member.
- 20 **[0035]** Figure 8B illustrates one embodiment of a side view of an ultrasonic monitor on a PCB having an air gap with a supporting member.
- [0036]** Figure 9A illustrates one embodiment of a perspective view of an ultrasonic monitor on a PCB having one air gap shared by two transducers.
- 25 **[0037]** Figure 9B illustrates one embodiment of a side view of an ultrasonic monitor on a PCB having one air gap shared by two transducers.
- [0038]** Figure 9C illustrates one embodiment of a front view of an ultrasonic monitor on a PCB having one air gap shared by two transducers.
- [0039]** Figure 10 illustrates one embodiment of the layers of a gel pouch.
- 30 **[0040]** Figure 11A illustrates one embodiment of a perspective view of a gel

pouch.

[0041] Figure 11B illustrates one embodiment of a side view of a gel pouch.

[0042] Figure 12A illustrates one embodiment of a gel pad configuration.

[0043] Figure 12B illustrates one embodiment of a gel pad configuration.

5 **[0044]** Figure 12C illustrates one embodiment of a gel pad configuration.

[0045] Figure 13A illustrates one embodiment of a perspective view of an ultrasonic monitor on a PCB with a mold.

[0046] Figure 13B illustrates one embodiment of a side view of an ultrasonic monitor on a PCB with a mold.

10 **[0047]** Figure 14A illustrates one embodiment of a side view of an encapsulated PCB board.

[0048] Figure 14B illustrates one embodiment of a side view of an encapsulated PCB board.

15 **[0049]** Figure 14C illustrates one embodiment of a side view of an encapsulated PCB board.

[0050] Figure 15A illustrates an embodiment of an ultrasonic monitor system with an encapsulated gel pad.

[0051] Figure 15B illustrates an embodiment of an ultrasonic monitor system with a gel pad attached in-situ.

DETAILED DESCRIPTION

[0052] The present invention, roughly described, pertains to ultrasonic monitors. The ultrasonic monitor uses ultrasonic signals to measure movement
5 inside the body of a living subject. The movement may be a heart contraction, flowing blood or movement of the blood vessel itself. From information collected from these movements, electronics within the monitor may determine blood flow rate, heart rate, or pulse rate of the living subject.

10 **[0053]** In one embodiment, the ultrasonic monitor measures blood flow through an artery of a person. The ultrasound signals reflected by blood vessel expansion (expansion due to blood moving through the vessel) have a frequency range similar to that of noise caused by muscle artifacts and tissue movement. The ultrasound signals reflected by the flowing blood itself have a frequency
15 range higher than muscle and tissue related noise. As a result, the signals reflected by flowing blood are easier to process to find the rate values than those reflected by expansion of the blood vessel itself.

[0054] The terms ultrasonic and ultrasound are used interchangeably herein
20 and refer to a sound wave having a frequency between about 30 KHz and about 30 MHz. An ultrasonic transducer, transducer or transducer element as used herein is a device used to introduce sonic energy into and detect reflected signals from a living subject. Ultrasonic transducers respond to electric pulses from a driving device and ultrasonic pulses reflected by a subject.

25

[0055] The ultrasonic monitor is comprised of an electronics portion and a transmission portion. The electronics portion includes the electrical components required to transmit, receive, and process the ultrasonic signals as discussed with respect to FIGs. 3-5. Processing may include amplifying,
30 filtering, demodulating, digitizing, squaring, and other functions typically signal

processing functions. Processing may be performed all or in part by digital circuitry. For example, the received ultrasonic signal can be digitized. The processing described herein to the received signal can then be performed by digital circuitry. The transmission portion includes a gel pad used as the transmitting medium between the monitor and the subject. The gel pad is positioned in direct contact with the living subject and the ultrasonic monitor.

[0056] In one embodiment, the monitor of the present invention is implemented on a printed circuit board (PCB). By implementing the circuitry on a PCB, the monitor system is efficiently be integrated to a very small footprint with a much lower power requirement. The transducers are mounted directly to the PCB.

[0057] The PCB can implement an ultrasound signal reflection layer. In one embodiment, a portion of the outer layer of the PCB is removed to create an air gap portion. Transducer elements are placed over the air gap portion. When driven, the transmitting crystal generates an ultrasound signal that travels towards the PCB in addition to the desired direction towards a target. The portion of the originally transmitted ultrasound signal traveling towards the PCB is reflected by the thin air gap away from the PCB and towards the intended target.

[0058] In some embodiments, a multi-layer gel pad is used to transmit ultrasonic signals between the ultrasonic monitor and the skin of the subject. The gel pad includes a gel layer adhered to a membrane layer. The membrane layer prevents diluents within the gel layer from escaping. This is advantageous when the gel includes elements that are not intended to make contact with the living subject or other surfaces.

[0059] In another embodiment, the PCB can be entirely encapsulated in plastic, water resistant gel, or a combination of the two. This provides for keeping the system of the ultrasonic monitor protected from debris such as dirt, dust and water. These advantages are discussed in more detail below.

5

[0060] The ultrasonic monitor may be implemented with a display. FIG. 2A illustrates a wrist worn ultrasonic monitor system 200 in one embodiment. System 200 includes an ultrasonic monitor module 210, a strap 220, a display device 230 and a gel pad 240. Ultrasonic monitor module 210 detects blood
10 flow through the radial artery at the subject's wrist. Heart rate data is then provided directly to display module 230. In one embodiment, connecting wires are molded into strap 220 between the ultrasonic monitor module 210 and display device 230.

[0061] The ultrasonic monitor can also be implemented with a remote display. The ultrasonic monitor system 250 of FIG. 2B includes monitor module 260, first strap 270 attached to monitor module 260, remote display module 280 and second strap 290 attached to remote display module 280. Ultrasonic monitor module 260 detects the blood flow through the radial artery
20 in the wrist. Heart rate data is then provided to remote display module 280. Monitor 260 can wirelessly transmit information to a remote display 280 using a wireless transmitter. The remote display 280 includes a receiver to receive the transmission from monitor 260. The remote display 280 may also be a monitor screen or other device. The ultrasonic monitor module 280 may be attached to
25 another part of the body (such as the chest over the subject's heart) with an adhesive or gel pad.

[0062] Determining what ultrasound signal frequency to use may depend on the particular object being monitored. The wrist offers a convenient location for
30 positioning the monitoring device. The relatively shallow focal depth of the

radial artery in the wrist suggests using a high frequency carrier signal.

[0063] The size of the transducer elements also affects the ultrasound signal frequency. Smaller electromechanical resonators emit at higher frequencies.

5 Transducer elements driven by high frequency signals tend to vibrate more rapidly and consume more power than those operating at lower frequencies. This is primarily due to internal loss. The ultrasonic monitor amplifier and demodulation circuits will also consume more power processing the higher frequencies

10

[0064] A block diagram of one embodiment of an ultrasonic monitor system 300 is illustrated in FIG. 3. Ultrasonic monitor system 300 includes a microcontroller 310, a transmitting transducer element 320 connected to microcontroller 310, a receiving transducer element 330, a radio frequency (RF) amplifier 340 connected to receiving transducer 330, a mixer 350 connected to RF amplifier 340 and microcontroller 310, an audio amplifier 360 connected to mixer 350, and band pass (BP) filter 370 connected to audio frequency amplifier 360 and microcontroller 310. Ultrasonic monitor system 300 may optionally include a local display 380 connected to microcontroller 310, a wireless transmitter 390 connected to microcontroller 310, a wireless receiver 392 receiving a wireless signal from wireless transmitter 390, and a remote display 394 connected to receiver 392.

15
20

[0065] In one embodiment, an ultrasonic monitor can be implemented with a system similar to that represented by block diagram 300, but with a driver circuit and high pass and low pass filters. In this case, the microcontroller drives driver circuitry with a carrier signal. The driver circuitry drives transmitting transducer to transmit an ultrasonic signal at a carrier frequency. The ultrasonic signal is reflected and received by receiving transducer. The received signal includes a frequency shift from the signal transmitted by

25
30

transducer. The received ultrasonic signal is amplified by RF amplifier circuitry. The amplified ultrasonic signal is then processed by a mixer, which demodulates the received signal and generates a signal with an audio range frequency. The resulting signal is then amplified by an audio frequency
5 amplifier circuit. The amplified audio signal is then filtered by a high pass filter circuit and a low pass filter circuit. The filtered signal is then received by the microcontroller. The microcontroller processes the filtered signal and provides an output signal to a wireless transmitter. The wireless transmitter transmits the signal through a wireless means to a receiver. A display then receives the signal
10 from the receiver and displays information derived from the signal.

[0066] Method 400 of FIG. 4 illustrates the operation of one embodiment of an ultrasonic monitor such as that represented in FIG. 3. An ultrasound signal is transmitted at step 410. With respect to system 300, microcontroller 310 drives
15 a transmitting transducer element 320 with a carrier signal f_C . As a result, the transmitting transducer generates an ultrasound signal. In one embodiment, the carrier signal may be within a range of 30 KHz to 30 MHz. In another embodiment, the carrier signal may be within a range of 1 MHz to 10 MHz. In yet another embodiment, the carrier signal is about 5 MHz.

20

[0067] A reflected ultrasonic signal is received at step 420. The reflected ultrasonic signal is generated by the reflection of the ultrasonic signal of step 410 by a blood vessel. When the ultrasonic monitor is worn on a wrist, the radial artery reflects the signal. The received ultrasonic signal will contain an
25 ultrasonic carrier frequency that has experienced a Doppler shift from the signal transmitted by transmitting transducer 320. The received signal is then amplified at step 430. In one embodiment, the amplifier 340 of system 300 is implemented as a radio frequency amplifier. The received ultrasonic signal is amplified by a factor that allows it to be processed for demodulation. Once the
30 ultrasonic signal is amplified at step 430, it is processed by a mixer 350 at step

440. The mixer uses the carrier signal f_C to demodulate the reflected ultrasonic signal in order to extract the Doppler signal. Accordingly, mixer 350 is driven by carrier signal f_C and the reflected ultrasound signal. The output signal provided by mixer 350 is then amplified at step 450 by an amplifier 360. As the
5 output of the mixer will have a frequency component in the audio range, Amplifier 360 is an audio amplifier designed to amplify the demodulated audio range Doppler frequencies.

[0068] After the demodulated signal has been amplified, the amplified
10 signal is filtered at step 460. In one embodiment, the filter of step 460 is a band pass filter. The band pass filter may be configured to remove aliasing effects, noise, and other unwanted frequency elements. In another embodiment, the band pass filter may be implemented with a high pass and low pass filter. After the signal is filtered at step 460, the signal is subject to additional processing at
15 step 470.

[0069] The additional processing of step 470 may include several steps depending on the ultrasonic monitor system. The processing may be performed by a microcontroller or other circuitry. Though methods vary, a typical
20 example of additional processing is illustrated in method 500 of Fig. 5. The filtered signal from step 460 of method 400 is processed by an analog to digital converter at step 510. In one embodiment, the digitization is performed if it was not performed earlier. The absolute value of the digitized signal is then determined at step 520. Alternatively, the square of the signal may be
25 determined at step 520. Next, the signal derived from step 520 is filtered by a low pass filter in step 530. The low pass filter removes noise and other unwanted frequency elements of the signal. Method 500 is an example of additional processing performed by an ultrasonic system. It is understood that processing of the signal may vary from system to system, and embodiments of
30 the ultrasonic monitor are not intended to be limited solely to the scope of the

example discussed. The heart rate is then derived at step 540. After the processing of steps 510-530, the resulting signal is a pulse signal retrieved from the receiving transducer. The signal appears as a series of pulses, wherein each pulse has an area as determined by the path of its amplitude to and from a peak
5 amplitude. The resulting heart rate, or pulse rate, is derived from the frequency of the pulses (for example, 160 pulses per minute corresponds to 160 heart beats per minute). The flow rate is determined by integrating the area underneath the waveform of the pulses.

10 **[0070]** The microcontroller of ultrasonic monitor can be implemented as one or more of several common microcontroller integrated circuits, including Samsung KS57C 3316 series, Samsung S3C7335, Intel 8051 series, and Texas Instruments MSP430 series microcontrollers. The mixer of the ultrasonic
15 frequency modulation ICs. A non-exclusive list of possible mixer ICs include NJC's NJM2295, NJM2292 and NJM2537 mixers, Toko's TK8336IM mixer, and Motorola's MC3371 mixer.

[0071] The transducers used in the present invention adhere to some general
20 design guidelines. The transducers of the ultrasonic monitors can be piezoelectronic transducers. The length of each transducer is generally at least one centimeter long. The transducer length is also generally equal or greater than five times its width. The frequency at which a transducer operates at is generally related to the thickness of the transducer. Several types of transducers
25 may be used in the present invention. One example is a K-350, Modified Lead Zirconate-Titanate transducer, by Keramos Division, Piezo Technologies. Equivalent materials to this type of transducer include PZT-5A or NAVY-II equivalent.

Ultrasonic Monitor on a Circuit Board

[0072] One embodiment of the ultrasonic monitor system is implemented on a printed circuit board (PCB). PCB technologies such as surface mount
5 (SMT) and chip-on-board (COB) can be used to implement the monitor on a PCB. Implementing the circuitry on a PCB integrates the monitor system to a very small footprint. This allows for a more efficient system, much lower power requirement, consistent product performance and reduced production cost.

10

[0073] Implementing the monitor system on a PCB allows for easy construction of an air gap portion. To generate the air gap portion, one or more sections of the outer layer of the PCB are removed. The transducers are then placed over the air gap portion. This creates an air gap portion having one or
15 more air gaps underneath the transducer elements. The air gap portion reflects ultrasonic signals away from the PCB and towards the desired direction. The air gap is more effective and much more easily constructed than foam layers of prior systems. Additionally, the transducer elements are mechanically isolated as a result of the air gap, thereby reducing any dampening or loading effect on
20 the transducers from contact by any other material. The air gap also serves to significantly reduce if not eliminate crosstalk noise between the transducers. In some embodiments, additional layers may be removed from the PCB to generate an air gap portion with a larger thickness. In this case, additional etching, drilling or other methods may be used to control the depth of the air
25 gap. In some embodiments, an air gap may be generated that penetrates the entire circuit board. This method provides for simple generation of an air gap that effectively reflects the ultrasound signal.

[0074] The ultrasonic monitor transmits ultrasound signals more efficiently
30 than prior monitors. The ultrasonic monitor transducers are mounted directly to

the PCB using conductive epoxy or solder paste. Transducers of previous systems are typically glued entirely to a supporting structure, such as a glass base plate. Attaching the entire surface of the transducers to a supporting structure creates a mechanical load that dampens the vibration of the transducers. The dampening reduces the efficiency and draws power from the ultrasonic signal. With a minimized load, transducers of the present invention can generate the same ultrasound signals of previous systems using less power.

[0075] The PCB may include several layers, for example, a power layer, a ground layer and an insulating layer. The insulating layer can isolate the transducers from the monitor system circuitry. In some four layer PCBs, there are four copper layers and three insulating layers. Two copper layers are outer layers and two are inner layers. In one embodiment, to isolate the two transducers electrically so that they won't interfere with the rest of the circuitry on the PCB, one of the inner copper layers immediate next to the transducers can be used as a ground plane or ground layer. This inner copper layer ground plane will shield RF interferences generated or received by the transducers. This prevents the circuitry from causing interference with the transducer signal transmissions. In one embodiment, one surface of the PCB may be used to implement the monitor system circuitry and the opposite surface may be used to mount the transducers. In another embodiment, the transducers may not be implemented on the same PCB as the monitor system circuitry.

[0076] FIG. 6 illustrates a top view of one embodiment of a monitor 600 implemented on a PCB. Monitor 600 includes outer layer 610, a first transducer 622 and a second transducer 624 mounted to outer layer 610, air gaps 626 and 627 residing underneath the transducers 622 and 624, respectively, dedicated copper pads 630 and 635, and connecting wires 640 and 645 connected between the dedicated copper pads 630 and 635 and the transducer elements 622 and 624, respectively. In one embodiment, the outer layer 610 is composed of a

conducting material such as copper plated in tin or gold.

[0077] FIG. 7 illustrates a side view of the monitor 750 implemented on a PCB and further illustrates circuitry 760 attached to the opposite surface of the
5 PCB. Circuitry 760 includes surface mount ICs and electrical components such as resistors and capacitors that can implement the electrical system of the ultrasonic monitor.

[0078] Most if not all of the construction of the PCB is automated.
10 Application of solder paste, placement of the transducer elements and wire bonding can all be automated by existing PCBA production technologies. This reduces manufacturing cost significantly. For typical electronic components such as resistors, capacitors and integrated circuits in surface mount packages, a stencil is used to apply solder paste to the PCB on one side first. An automatic
15 pick and place machine then places these components. The PCB is then subjected to an infrared (IR) furnace which melts solder paste and forms electrical connections between the components and the underlying circuit pre-etched on the PCB. The same steps can be applied to mount the transducer elements on the opposite side of the PCB. This tremendously reduces the
20 production cost and enhances product performance consistency.

[0079] Air gap portions 626 and 627 of FIGs. 6 and 7 are constructed by removing a portion of the outer layer. Chemical etching can be performed to remove a portion of the outer layer of a PCB. Accordingly, the depth of the air
25 gap portion is the thickness of the layer removed. The area of outer layer 610 etched away is proportional to the surface area of the transducers 622 and 624. Air gap portions 626 and 627 are constructed so that the transducer elements 622 and 624 slightly overlap the air gap portion. This overlap of the transducer allows the ends of the transducers to be mounted to the outer layer of the PCB.

[0080] The air gap portion of the present invention may be implemented in several ways. In the embodiment illustrated in FIGs. 6 and 7, the air gap portion is a single undivided area underneath each transducer. The air gap extends about as long as the width of the transducer and slightly shorter than the length of the transducer. FIG. 8A is a top view of an embodiment of a monitor 800 implemented on a PCB. Monitor 800 includes PCB outer layer 810, transducers 822 and 824 connected to the outer layer, air gaps 826 and 827 underneath transducer 822 and separated by supporting member 830, air gaps 828 and 829 underneath transducer 824 and separated by supporting member 831, copper contact pads 840, and connecting wires 845 connecting copper pads 840 to transducers 822 and 824. FIG. 8B is a side view of monitor 800 implemented on a PCB and further illustrates circuitry 860 attached to the opposite surface of the PCB. The air gap portion of FIGs. 8A and 8B includes two air gaps. The air gap portion extends about as long as the width of the transducer and slightly shorter than the length of the transducer. However, the air gap portion for each transducer includes a support member. Thus, the air gap portion for transducer 822 is comprised of air gap 826, air gap 827 and support member 830 and the air gap portion for transducer 824 is comprised of air gap 828, air gap 829 and support member 831.

20

[0081] The support member is constructed by leaving a portion of the outer layer of the PCB over which the transducer will reside. In the embodiment of FIGs. 8A and 8B, support members 830 and 831 are thin strips extending across the width of the air gap portion and located at about the middle of the length of the transducer. In different embodiments, the support members can be implemented with different shapes and locations within the air gap portion of the PCB. For example, the support member can be implemented as a strip extending less than the entire width of the air gap portion, a strip along the length of the air gap portion, or as a plurality of small regions within the air gap portion. When implemented as one or more regions, the supporting member

30

can be isolated from the remainder of the outer layer or contact with a portion of the outer layer. The support member can support a transducer should the transducers receive pressure from an outside force.

5 **[0082]** FIGs. 9A-C depict an embodiment of a monitor 900 implemented on a PCB. FIG. 9A provides a top view of monitor 900. Monitor 900 includes first layer 910, mounting layer 940 and 942 attached to the first layer, transducers 920 and 922 mounted to mounting layers 940 and 942, respectively, air gap 945 located underneath transducers 920 and 922, air gap channels 946
10 and 948 located between mounting layers 940 and 942, and copper pad 951. Mounting layers 940 and 942 have a u-shape. The mounting layers can be implemented by removing a portion of a PCB layer to form the u-shaped layer or by attaching a u-shaped member to a layer of the PCB. In some
15 embodiments, one or more mounting layers having positions and shapes that differ from those illustrated in FIGs. 9A-C can be implemented to support and provide an air gap underneath each transducer. FIG. 9B is a cut-away side view of monitor 900 from the perspective indicated by the arrow in FIG. 9A. FIG. 9B illustrates the monitor implemented on a PCB with transducer 920 mounted
20 to mounting layer 940, mounting layer 940 attached to first layer 910, air gap 930 underneath transducer 920, and circuitry 960 attached to the opposite surface of the PCB. FIG. 9C is a front view illustrating the monitor 900. In the monitor of FIGs. 9A, 9B and 9C, the outer layer is removed to form an undivided air gap underneath transducers 920 and 922. The removed portion extends around the transducers to reveal portions of the underlying layer 910
25 not covered by the transducer elements.

[0083] As illustrated in the PCB of FIGs. 7A-B, 8A-B, and 9A-C, the transducer is mounted to the outer layer of the PCB where the transducer length slightly overlaps the air gap portion. In some embodiments, the air gap portion
30 can be formed such that the transducer is mounted to the PCB where the

transducer width slightly overlaps the air gap. In one embodiment, the width and length of the air gap portion will not be made larger than the width and length of the transducer elements. This prevents any silicone based epoxy or molten thermoplastic gel that may be applied to the transducer from getting into
5 the air gap portion. If epoxy or gel does penetrate the air gap, the acoustic impedance of the gel and the exposed fiber glass material comprising the PCB are different enough that the ultrasound energy will still be effectively reflected towards the desired direction. Since the air gap is relatively thin, the loss of energy, if any, will be negligible.

10

Gel Pad for Ultrasonic Frequency Transmission

[0084] A gel pad is used to transmit the ultrasonic frequency signal between
15 the ultrasonic monitor and the subject. The gel pad is in contact with the subject's skin and either the transducers or a surface that is directly or indirectly in contact with the transducers, such as an RTV layer. Gels having high oil content are generally transparent to ultrasound. Thus, the energy loss during transmission is minimized significantly. This allows the ultrasonic monitor to
20 effectively measure both the blood flow rate and cardiac output accurately.

[0085] In one embodiment, the gel pad may be implemented as a gel pouch. FIG. 10 illustrates one embodiment of a gel pouch. Gel pouch 1000 includes a gel layer 1010, primer layers 1020 and 1030, membrane layers 1040 and 1050,
25 and adhesive layers 1060 and 1070. The gel layer 1010 is the primary transmitting medium of the gel pouch. The primer layer can be applied to the surface of the gel layer. In an embodiment wherein the gel layer is generally shaped to have a top and bottom surface, a primer layer may be applied as an upper primer layer 1020 and/or a lower primer layer 1030. A membrane layer
30 is attached to the gel layer via the primer layer. The membrane layer serves to

aid in the handling of softer gels and prevents diluents from making contact with the subject's skin. Upper membrane layer 1040 is attached to upper primer layer 1020 and lower membrane layer 1050 is attached do lower primer layer 1030. The membrane layer can be applied to one or more surfaces of the gel layer. An adhesive layer may then be applied to the outer surface of the membrane layer. The adhesive is used to attach the gel pouch to the subject's skin, the transducer, or an RTV element in contact with the transducer. The adhesive may also eliminate any air pockets that may exist between the gel pouch and other surfaces. An upper adhesive layer 1060 may be applied to upper membrane layer 1040 and a lower adhesive layer 1070 may be applied to lower membrane layer 1050.

[0086] FIG. 11A illustrates a top view of one embodiment of a gel pad 1180. Gel pad 1180 includes gel pouch 1182, first cover 1184 and second cover 1186. FIG. 11B illustrates a side view of gel pad 1180. Gel pouch 1182 generally holds a flat disk-like shape. The covers are applied to the gel pouch during manufacturing and protect it until it is used. The covers can be constructed of wax paper or some other type of material. The gel pouch is used as a disposable gel pad with the ultrasonic monitor. Just before use, the covers are removed from the gel pouch. The gel pouch is then applied to the area between the ultrasonic monitor and the subject's skin. In one embodiment wherein the monitor is worn on the wrist, the gel pouch is applied between the wrist worn monitor and the subject's wrist. One embodiment of the monitor provides a recess in the outer surface of the monitor that is applied towards the subject. The gel pouch can be applied to the recessed area on monitor to help keep it in place. When the gel pad includes a pressure sensitive adhesive and is compressed between the monitor and the subject, the gel pad may adhere to both the monitor and the subject. The gel pad may be compressed when the monitor strapped to a subject, held in place without a strap for a period of time, or in some other manner that straps, fastens or otherwise applies the monitor to

the subject.

[0087] The gel pad shape and the thickness can be designed to allow ultrasonic monitors to operate at different bias angles. Gel pad orientation 1200 of FIG. 12A illustrates a monitor module 1205 attached to a gel pad 1210 having a rectangular cross section. Gel pad orientation 1220 of FIG. 12B illustrates a monitor module 1225 attached to a gel pad 1230 having a triangular cross section. Gel pad orientation 1240 of FIG. 12C illustrates a monitor module 1245 attached to a gel pad 1240 and Figure 12C having a trapezoidal cross section. The dimensions of these gel pad shapes are based on the desired bias angle and the depth of the moving object to be detected.

[0088] Several types of materials can be used in constructing the gel pad of the present invention. The gel layer of the gel pad (gel 1010 of FIG. 10) may be constructed of thermoplastic gel, thermoset gel, hydrogels, or other similar materials. A thermoplastic gel is generally made of a thermoplastic elastomer with a large proportion of interdispersed diluent. Thermoplastic elastomers include block copolymers such as styrene-butadiene-styrene, styrene-isoprene-styrene, styrene/ethylene-co-butylenes/styrene, and styrene/ethylene-copropylene/styrene. The styrene end blocks form glassy domains at room temperature. The glassy domains act as physical crosslinks that provide the elastomeric properties of the polymer. During heating above the glass transition temperature of styrene, *i.e.*, about 100°C, the glassy domains melt and the polymers revert to a liquid state. During cooling, the glassy domains re-form again. Hence, the process is reversible. Other block copolymers, such as ethylene-(ethylene-co-butylene)-ethylene copolymers which contains crystalline polyethylene end blocks, can also be used to prepare thermoplastic gels.

[0089] A thermoset gel, such as a polyurethane or silicon gel, is generally made of a chemically bonded three-dimensional elastomeric network which

entrap a large amount of low volatility liquids or diluents. The elastomeric network is permanent and cannot be reversed to a liquid state through heating. A certain amount of diluent is necessary in order to ensure good conformability of the gel to the skin and low attenuation for ultrasound transmission while still maintaining the load bearing properties. The gel can be used at a temperature that ranges from -30°C to +70°C, wherein the gel maintains its shape and load-bearing elastic properties.

[0090] Thermoset and thermoplastic gels invariably contain a large percentage of diluents entrapped in an elastomeric network. When properly formulated, these gels are stable and can resist stress or temperature cycling. The stability is governed by thermodynamic factors such as the crosslink density of the elastomeric network and the compatibility of the diluents with the elastomeric network. However, even with a thermodynamically stable gel, when brought in contact with skin, the diluents in the gel can still diffuse out and enter the living subject. This is due to the fact that there is a concentration gradient of the diluents across the skin; the natural tendency for the diluents is to migrate out of the gel, where the concentration of the diluents is high, and into skin, where the initial concentration of diluents is zero. The diffusion is thus kinetically controlled by the Fick's Law. The diffusion of diluents, particularly silicone oil, may have a deleterious effect to the living. In one embodiment, the diffusion of the diluents is prevented by adhering or laminating a compliant barrier membrane to the gel layer.

[0091] Hydrogels can consist of a water soluble polymer such as polyacrylic acid, polyacrylamide, poly (acrylic acid-co-acrylonitrile), poly(acrylamide-co-acrylonitrile), etc. They are dissolved in a large amount of water, approximately 50% to 98% by weight of the total mixture. The mixtures are optionally thickened by ions such as sodium, zinc, calcium, etc., which are provided by adding the corresponding metal salts. When used with a membrane, the

membrane can effectively seal the mixtures to prevent the water evaporation or migration.

[0092] The membrane layer may be made of a thin film of polyurethane, 5 silicone, poly(vinyl chloride), natural or synthetic rubbers, polyester, polyamides, or polyolefins which include low density polyethylene, plastomers, metallocene olefin copolymers, or other similar materials. In fact, any thin polymer film that is pliable and conformable is within the scope of this invention. Those skilled in the art can determine a suitable membrane material 10 depending on the gel material selected. The membrane can be laminated to the gel pad using an adhesive. The membrane can also be formed by spraying of coating a film forming liquid such as a polyurethane elastomer solution, or latex onto the surfaces of the gel layer. Upon drying of the liquid, a thin membrane is formed which can achieve the same result as the laminating process. 15 Depending on the type of diluents in the gel layer, a membrane is selected to give the best barrier effect. The membrane is preferably as thin and soft as possible so that it complies to the skin well and minimizes the possibility of air entrapment. The membrane also provides for easier gel pad handling, reduced dirt accumulation, and easier cleaning.

20

[0093] Several types of adhesives and primers may be used to generate the gel pouch of FIG. 10 and 11A-B. For example, Automix™ Polyolefin Adhesion Promoter 05907 by 3M™ and LOCTITE™ 770 Polyolefin Primer by Loctite can be used as a primer between the gel layer and membrane layer. 25 AROSET™ 3250 pressure sensitive adhesive by Ashland Specialty Chemical Company can be used as the adhesive between a membrane layer and the subject's skin. DOW CORNING 7657 Adhesive used with SYL-OFF 4000 Catalyst by Dow Corning™ may be used as an adhesive between the membrane layer and an RTV element.

30

[0094] The pressure sensitive adhesive applied to the outer surface of the membrane layer can be rubber, silicone or acrylic based depending on the based material of the gel. For example, if thermoplastic gel is used, a rubber based pressure sensitive adhesive will provide better adhesion. It is also preferable that
5 the pressure sensitive adhesive is medical grade that does not cause skin sensitization. If a membrane is in direct contact with the skin, it is also desirable that the membrane itself does not cause skin sensitization. Some membrane materials made of natural rubber latex are known to cause allergic reaction to the skin of some people.

10

[0095] In another embodiment, the gel pad may consist of a single layer of thermoplastic gel material. This is particularly convenient if a biocompatible fluid such as medical grade mineral oil is used as the diluent in the gel. Such oil, if migrates into the skin, does not cause adverse effect to the living tissues.
15 For example, baby oil, a medical grade mineral oil, may be used for the diluent. In this case, the thermoplastic gel material is compliant enough to the surface of the subject such that no adhesive is needed between the gel pad and the subject's skin. In particular, when applied with a slight amount of pressure, such as that applied by a wrist-worn ultrasonic monitor with a wrist-strap, any
20 existing air pockets are generally eliminated. Minimum adhesion is required to keep the single layer thermoplastic gel pad in place when in contact with the ultrasonic monitor and a subject's skin. This is advantageous because it is simple, inexpensive to construct and allows a large number of adhesives to be used to keep the gel pad in contact with the RTV. In one embodiment, the gel
25 may have a thickness of between about 1 and 10 millimeters. In some embodiments, the gel may have a thickness between 1 and 5 millimeters.

[0096] The gel pad may be attached to the ultrasonic monitor in several ways. In one embodiment, a thermoplastic gel may be heated to a molten state
30 and over-molded onto the plastic housing of the transducer. Though the

thermoplastic gel will adhere to the transducer, an adhesive may be used to ensure a durable bond. Examples of such an adhesive include Versaflex6000 by GLS Corporation and Monprene by Teknor Apex Corporation. In one embodiment, the adhesive may be over-molded by injection molding before the gel is over-molded. Adhesives suitable for over-molding include EC6000 by ECLECTRIC PRODUCTS, Inc. A membrane layer may then be laminated over the gel layer to prevent diffusion of diluents.

[0097] In another embodiment, a mold is utilized to form a portion of the transmitting medium. In this case, a mold that encompasses the transducers and a portion of the PCB outer surface is mounted to the PCB. Room temperature vulcanizing (RTV) silicone rubber layer adhesive is then placed into the mold. Though the RTV layer will adhere to the exposed PCB surface within the mold, an adhesive may be used to further secure the RTV to the PCB. RTV provides excellent ultrasonic signal transmission and is slightly firmer than a thermoplastic gel pad. The firmness of the RTV layer can prevent damage to the transducer elements due to contact from the gel pad and other objects.

[0098] An embodiment of a PCB system that incorporates a molded RTV layer is shown in FIGs. 13A and 13B. The monitor of system 1300 in FIG. 13A includes an outer layer 1310 of a PCB, transducers 1320 and 1330 mounted to the outer layer, RTV mold 1340, copper contact points 1342, connecting wires 1344 that connect copper contact points 1342 to transducers 1320 and 1340, air gap portions 1322 and 1324 underneath transducer 1320 and air gap portions 1326 and 1328 underneath transducer 1330. FIG. 13B illustrates a side view of the PCB system and further illustrates circuitry used to implement the monitor that is mounted to the opposite surface of the transducers. The RTV mold is constructed such that it encompasses the transducers, air gap portions, and a portion of the outer layer of the PCB. Connecting wires 1344 may be located over or under the mold. The mold may be implemented as a solder mold and

attached to the PCB using appropriate adhesives as discussed above. The RTV material is placed into the RTV mold during production. The gel pad may then be attached to the RTV using an appropriate adhesive.

5 **[0099]** In one embodiment, the gel layer portion of the gel pad can be molded over the RTV material. The membrane layer and/or polyurethane portion of the gel pad can then be applied over an outer surface of the gel layer. The membrane layer may be applied with or without an adhesive. In this embodiment, a membrane layer is not applied to the gel layer surface in contact
10 with the RTV layer (i.e., the membrane is not used between the RTV material and the gel layer in this embodiment). The outer surface of the membrane layer can then be placed in contact with a subject's skin. An adhesive may optionally be applied to the outer surface of the membrane layer in contact with a subject's skin.

15

[00100] The RTV material can be selected such that it acts as a mechanical isolator between the transducers and outside forces. The RTV material absorbs outside forces, such as contact or pressure from a subject's skin, and prevents them from affecting the resonating frequency of the transducers. The RTV may
20 be constructed from several types of materials, including Silastic™ E RTV Silicone Rubber and DOW CORNING 3110, 3112 and 3120 RTV rubbers, all by DOW CORNING™. DOW CORNING™ 1301 primer and other similar primers may be used to attach the RTV material to the PCB.

25 Encapsulated Ultrasonic Monitor

[00101] In one embodiment of the present invention, the ultrasonic monitor can be encapsulated to make it water resistant. The ultrasonic monitor can be sealed using an ABS plastic material, gel material, or both. For instance, the
30 electronic component side can be sealed in ABS plastic material while the

transducer side is sealed by a softer gel material such as a thermoplastic with high oil content. In another embodiment, both the transducer side and the electronic component side can be sealed using an ABS plastic material.

5 **[00102]** The sealed assembly can be formed with a recessed portion located over the transducers or an RTV portion of the ultrasonic monitor. A disposable gel pad may be placed in-situ at the recessed area to improve ultrasonic signal transmission and maintain the position of the gel pad. The gel pouch illustrated and discussed in reference to FIGs. 11A-B can be used in this embodiment. In
10 some embodiments, the resulting assembly can be further molded or mechanically coupled in some way to a polyurethane based wristwatch strap. Both final assemblies will be waterproof and retain good ultrasonic transmission properties with a subject.

15 **[00103]** FIG. 14A illustrates an embodiment of a sealed ultrasonic monitor 1400. Monitor 1400 includes PCB 1410, circuitry 1412, plastic housing 1414, gel or epoxy layer 1420, transducers 1422 and 1424 and gel pad 1425. PCB 1410 circuitry 1412 are molded and sealed in plastic (such as ABS plastic) housing 1410. The gel or epoxy layer 1420 is molded or cast over the
20 transducers and sealed against the plastic housing.

[00104] FIG. 14B illustrates an embodiment of a sealed ultrasonic monitor 1430. Monitor 1430 includes PCB 1440, circuitry 1442, plastic housing 1444, adhesive layer 1450, gel or epoxy layer 1452, transducers 1454 and 1456 and
25 gel pad 1458. Monitor 1430 is similar to monitor 1400 except that adhesive layer 1450 is applied over the transducers and PCB.

[00105] FIG. 14C illustrates an embodiment of a sealed ultrasonic monitor 1460. Monitor 1460 includes PCB 1470, circuitry 1472, plastic housing 1474,
30 gel or epoxy layer 1480, transducers 1482 and 1484 and gel pad 1490. Monitor

1460 is similar to monitor 1400 except the plastic housing 1474 encloses the entire monitor.

[00106] An encapsulated ultrasonic monitor may be used with a permanently
5 attached gel pouch or a disposable gel pouch that can be attached in-situ. An
embodiment of a wrist worn ultrasonic monitor 1500 that is encapsulated in a
housing is illustrated in FIG. 15A. Monitor 1500 includes ultrasonic monitor
module 1510, gel pad 1515 attached to monitor module 1510, display device
1530, and strap 1520 attached to the display device and monitor module. The
10 gel pouch 1515 is attached to the monitor module during production. In one
embodiment, the gel pad can be attached to the monitor module 1510 through a
molding process. One embodiment of a wrist worn ultrasonic monitor 1580 that
is encapsulated in a housing is illustrated in FIG. 15B. Monitor 1580 includes
ultrasonic monitor module 1560, disposable gel pad 1565 attached to monitor
15 module 1560, display device 1580, and strap 1570 attached to the display device
and monitor module. The disposable gel pouch 1565 can be attached to the
monitor module just before the monitor is used. Ultrasonic monitor modules
1510 and 1560 contain slightly different shapes. This is to provide examples
only. The shapes of ultrasonic monitor modules of FIGs. 15A and 15B are
20 interchangeable and are not intended to limit the scope of the present invention.

[00107] The foregoing detailed description of the invention has been
presented for purposes of illustration and description. It is not intended to be
exhaustive or to limit the invention to the precise form disclosed. Many
25 modifications and variations are possible in light of the above teaching. The
described embodiments were chosen in order to best explain the principles of
the invention and its practical application to thereby enable others skilled in the
art to best utilize the invention in various embodiments and with various
modifications as are suited to the particular use contemplated. It is intended that
30 the scope of the invention be defined by the claims appended hereto.

CLAIMS

We claim:

1. An ultrasonic monitor comprising:
5 a circuit board; and
one or more ultrasonic transducers mounted to the circuit board with one or more air gaps between the circuit board and the one or more transducers.
2. The ultrasonic monitor of claim 1, wherein the one or more air gaps
10 includes a first air gap positioned underneath a transmitting transducer and a second air gap positioned underneath a receiving transducer.
3. The ultrasonic monitor of claim 2, wherein the first air gap has an area
15 about the same as the area of the transmitting transducer element and the second air gap has an area about the same size as the area of the receiving transducer element.
4. The ultrasonic monitor of claim 1, wherein the one or more air gaps are
20 formed by removing a portion of the circuit board.
5. The ultrasonic monitor of claim 1, wherein the one or more air gaps is
an undivided air gap underneath a transmitting transducer and a receiving transducer.
- 25 6. The ultrasonic monitor of claim 1, wherein the air gap portion includes a support member underneath each of said transmitting transducer element and said receiving transducer element.

7. The ultrasonic monitor of claim 1, wherein the one or more air gaps includes two air gaps separated by a support member, at least one transducer mounted over the support member.
- 5 8. An ultrasonic monitor comprising:
a circuit board having an outer layer;
a transmitting transducer mounted to said circuit board;
a receiving transducer mounted to said circuit board, the outer layer
including one or more air gaps located underneath the transmitting transducer
10 element and the receiving transducer element; and
a circuit configured to process the received ultrasonic signal.
9. The ultrasonic monitor of claim 8, wherein the one or more air gaps are
formed by removing a portion of the outer layer.
- 15 10. The ultrasonic monitor of claim 8, wherein the transmitting transducer
and the receiving transducer have a slightly longer length than the air gap
portion.
- 20 11. The ultrasonic monitor of claim 8, wherein the one or more air gaps is
an undivided portion underneath the transmitting transducer and the receiving
transducer.
12. The ultrasonic monitor of claim 8, wherein the one or more air gaps
25 includes a support member underneath each of said transmitting transducer and
said receiving transducer.
13. The ultrasonic monitor of claim 12, wherein the support member is
comprised of a strip of an outer layer of the circuit board.

14. The ultrasonic monitor of claim 8, further comprising:
a housing member containing the transmitting transducer, the receiving transducer, and the circuit.
- 5 15. The ultrasonic monitor of claim 14, further comprising:
a strap member connected to the housing member.
16. A method for constructing an ultrasonic monitor comprising:
accessing a circuit board;
10 removing at least a portion of a layer of the circuit board to form one or more air gaps; and
mounting one or more transducers to the circuit board so that the one or more air gaps are between the one or more transducers and the circuit board.
- 15 17. The method of claim 16 wherein said removing at least a portion of the outer layer is performed by chemical etching.
18. The method of claim 16 wherein said removing at least a portion of the outer layer includes generating an aperture in the circuit board.
- 20 19. The method of claim 16 wherein removing a portion of the circuit board includes:
removing a first portion of the circuit board to form a first air gap; and
removing a second portion of the circuit board to form a second air gap,
25 the first air gap and the second air gap isolated from each other by a portion of the circuit board, the circuit board configured to receive the transmitting transducer over the first air gap and the receiving transducer over the second air gap.
- 30 20. The method of claim 19 wherein removing the first portion includes:

removing an area of the outer layer about the same size as the transmitting transducer except for a supporting member, the supporting member positioned to support a portion of the transducer.

- 5 21. The method of claim 20 further including:
mounting a transmitting transducer, a receiving transducer and circuitry to the circuit board, the transmitting transducer and receiving transducer mounted directly to the circuit board over the air gap portion.
- 10 22. A method for monitoring a heart rate, comprising:
transmitting an ultrasonic signal from a transmitting transducer mounted on a circuit board, the ultrasonic signal transmitted in a first direction towards a target located away from the circuit board and in a second direction towards the circuit board;
15 reflecting the signal transmitted towards the circuit board towards the target by an air gap, the air gap positioned underneath the transmitting transducer; and
receiving a reflected ultrasound signal by a receiving transducer.
- 20 23. The method of claim 22 wherein the air gap is formed by removing a portion of the circuit board located underneath one of the transducers.
24. The method of claim 22 wherein the air gap portion is positioned underneath both the transmitting transducer and the receiving transducer.
- 25 25. The method of claim 22 wherein the air gap is an aperture through the circuit board.
26. The method of claim 22 wherein reflecting includes:

reflecting the signal with a first air gap and a second air gap, the first air gap and the second air gap isolated from each other by a portion of the circuit board.

- 5 27. The method of claim 22 wherein the first air gap portion includes a support member, the support member comprised of a portion of an outer layer of the circuit board and positioned underneath the transmitting transducer.

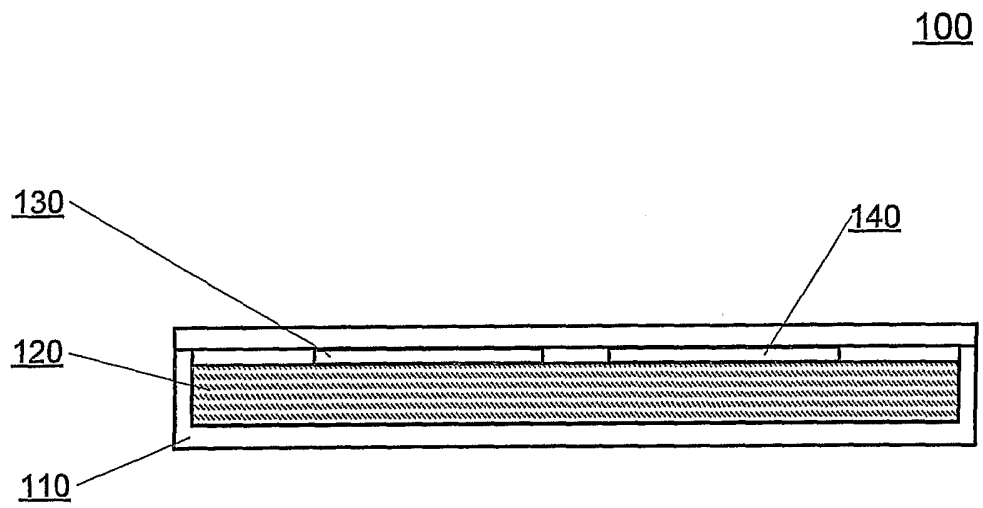

Figure 1

200

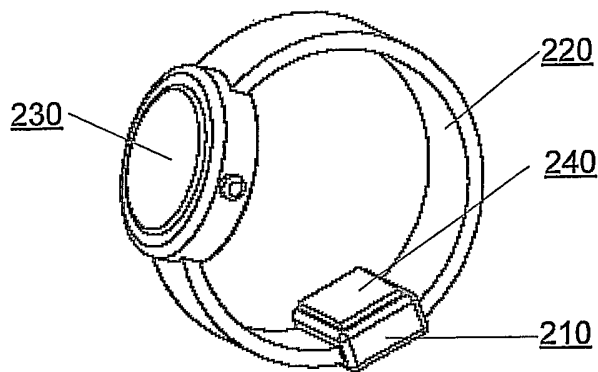

Figure 2A

250

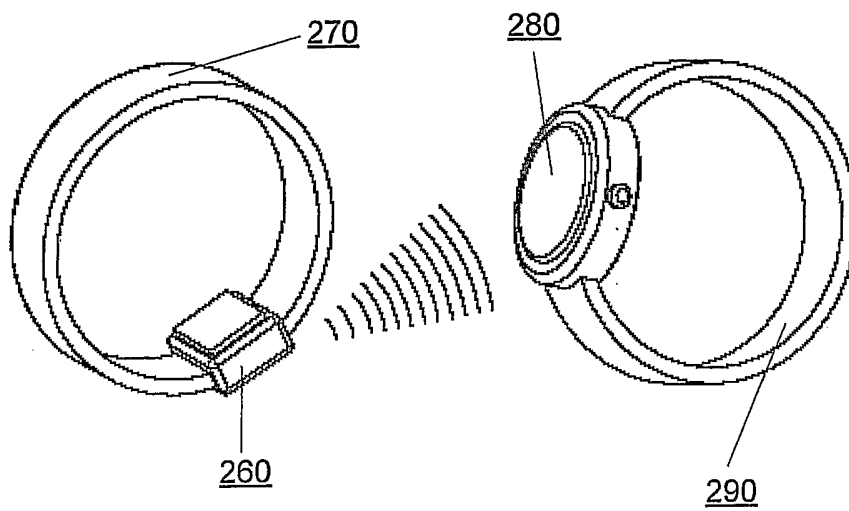

Figure 2B

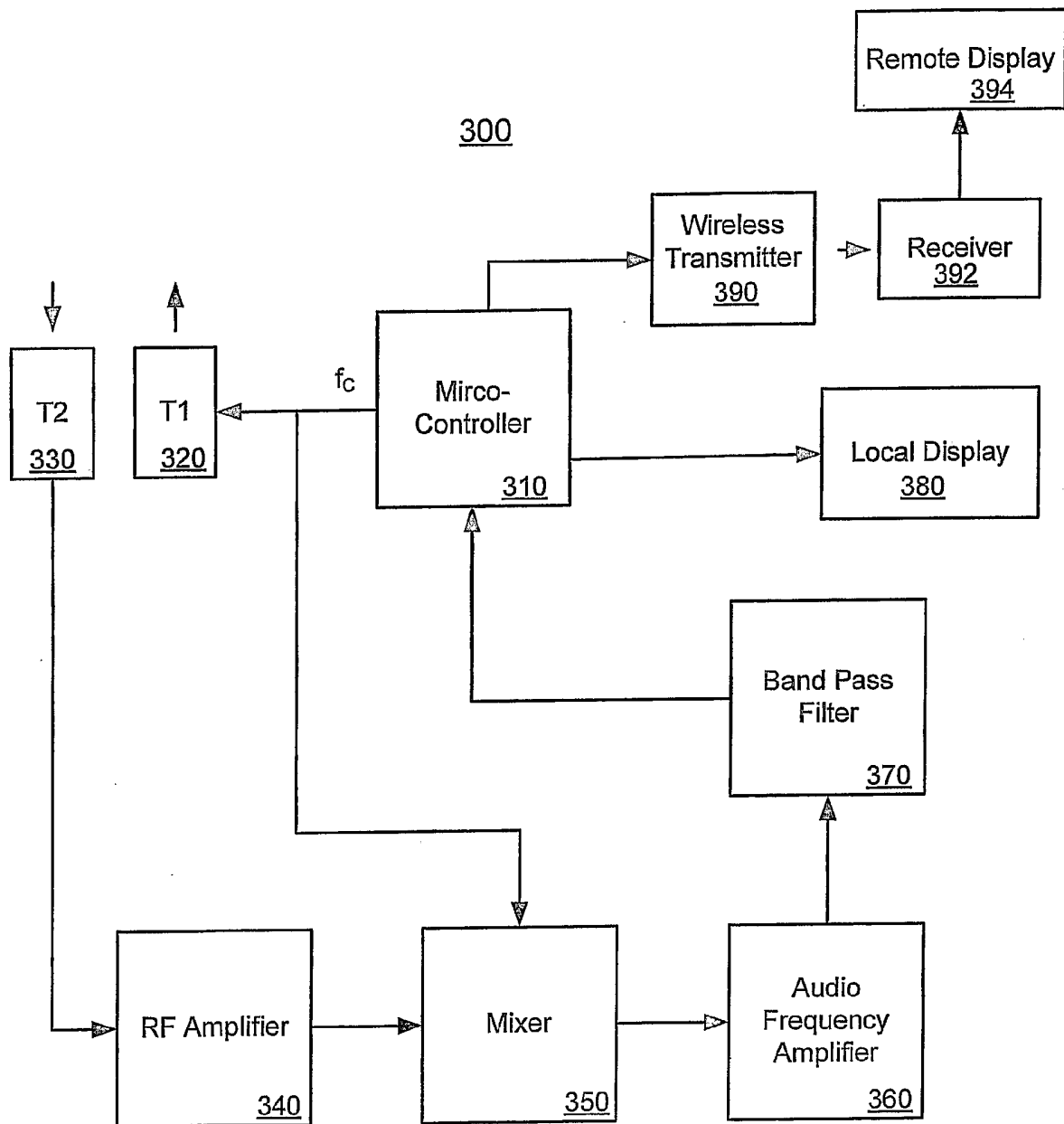

Figure 3

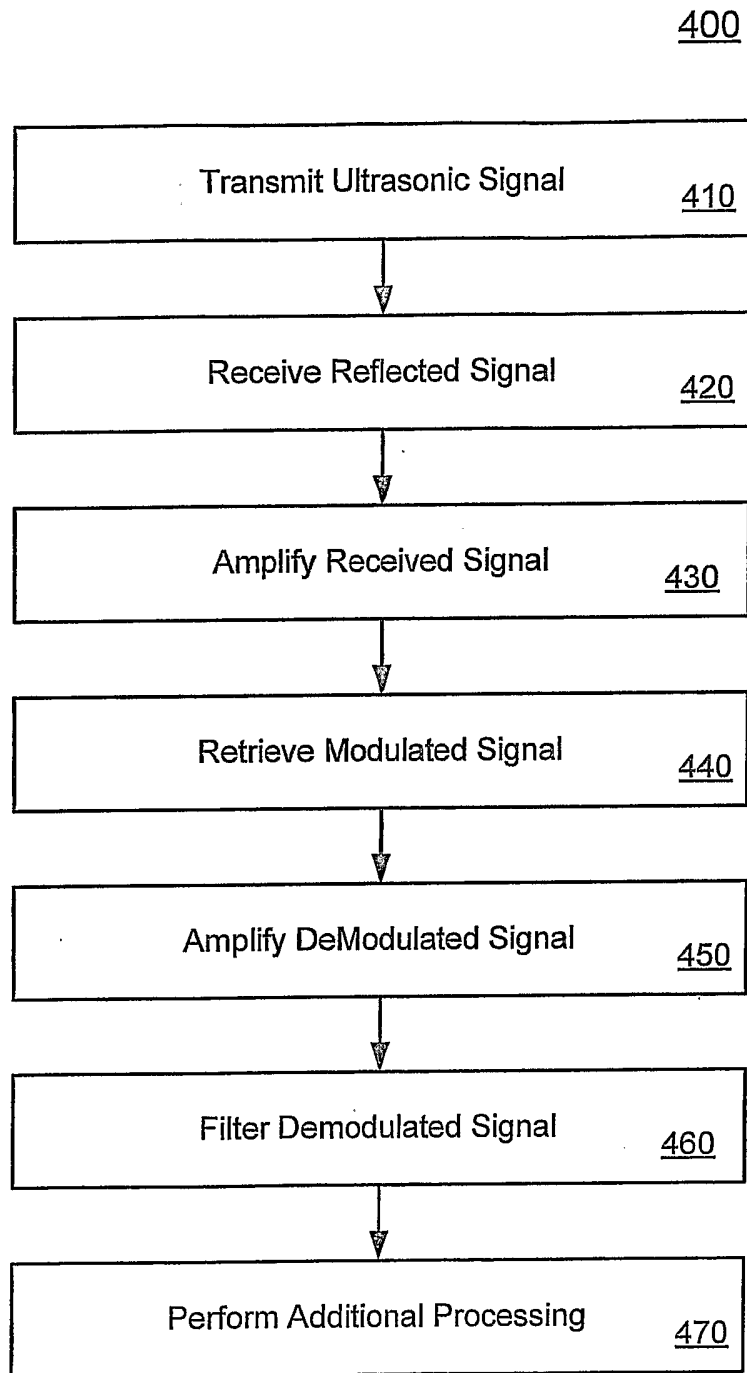

Figure 4

500

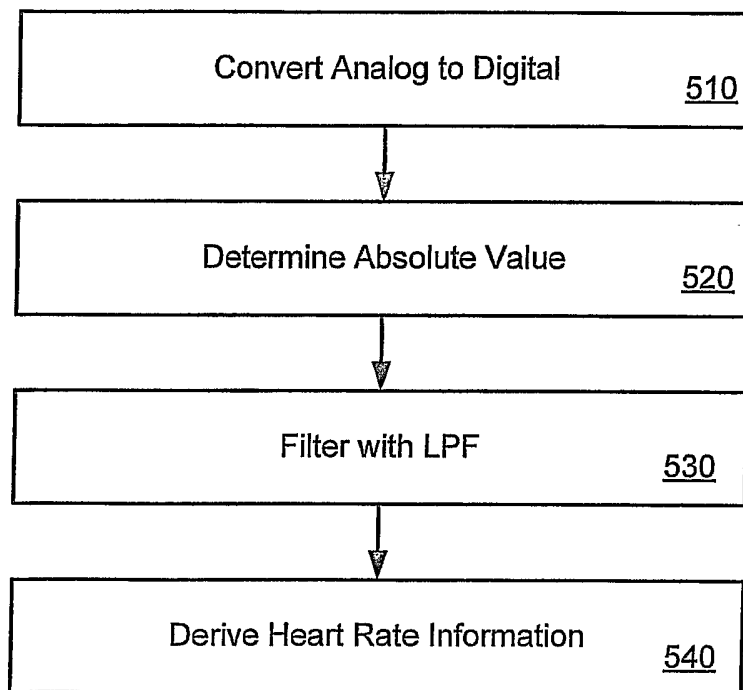

Figure 5

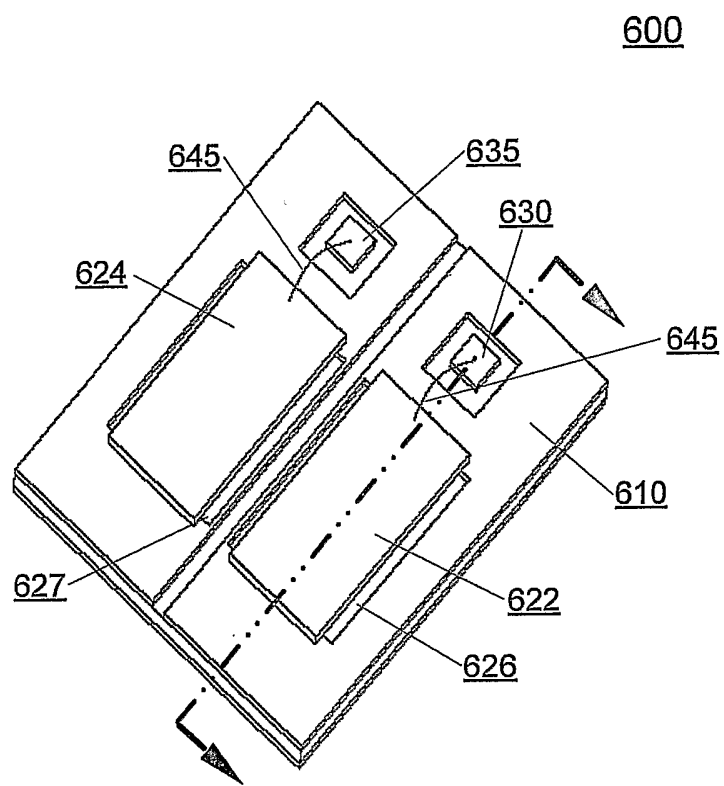

Figure 6

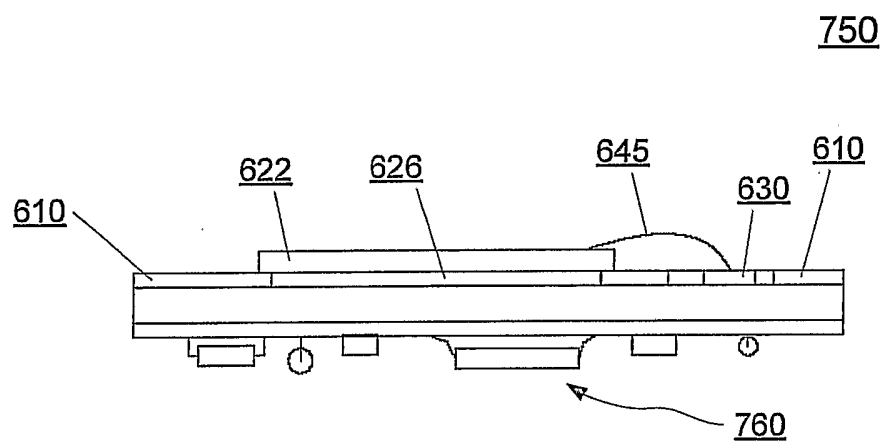

Figure 7

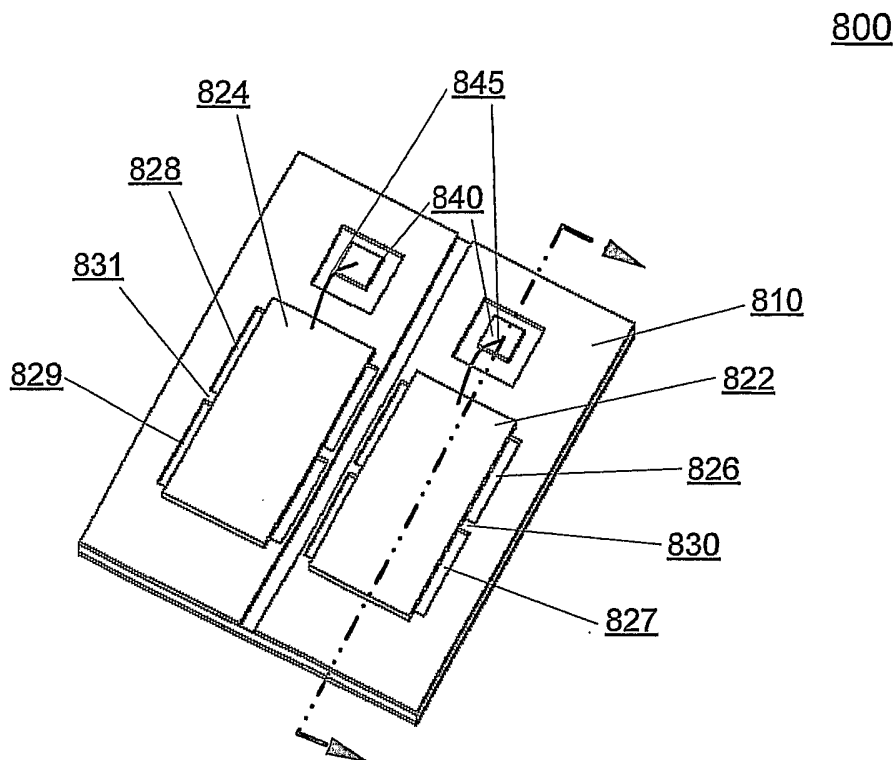

Figure 8A

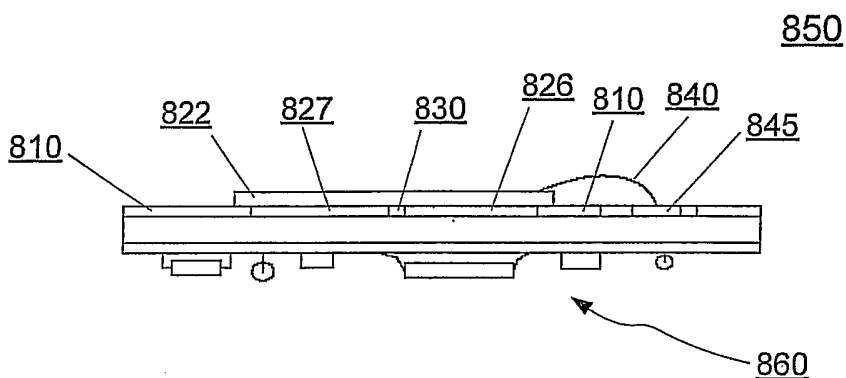

Figure 8B

Figure 9A

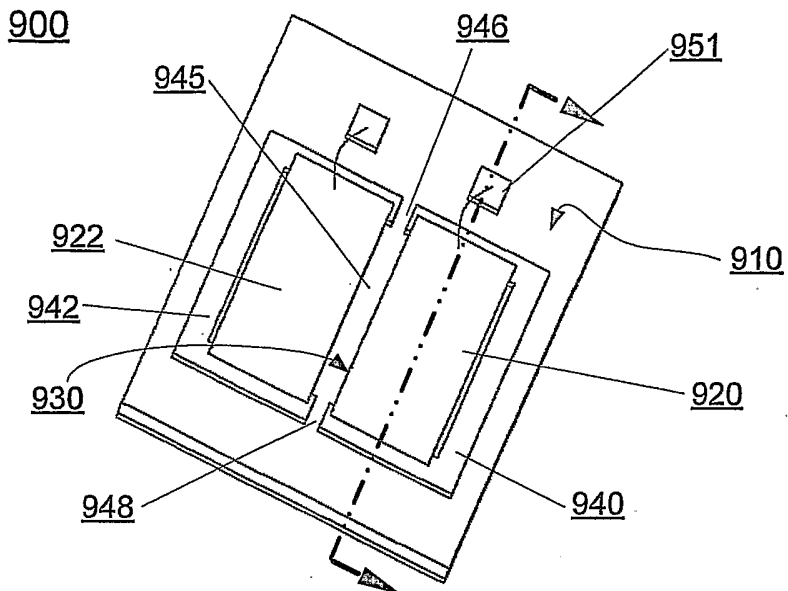

Figure 9B

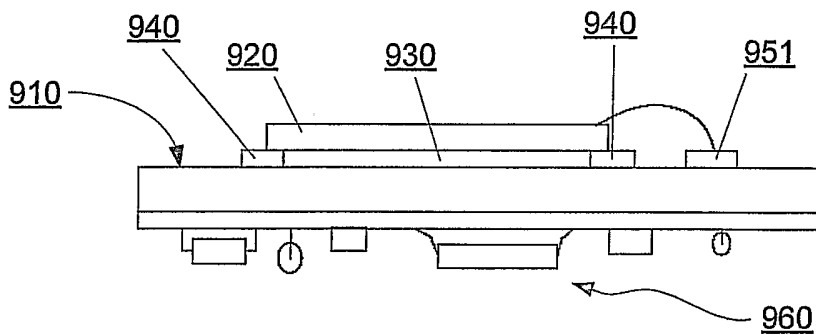
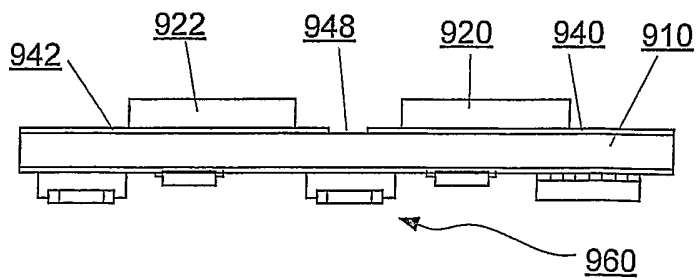

Figure 9C



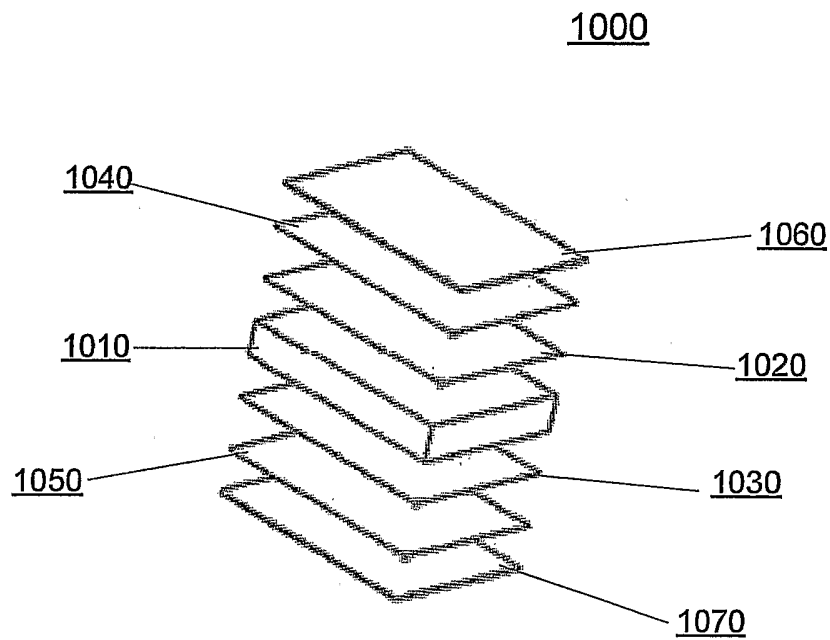

Figure 10

1180

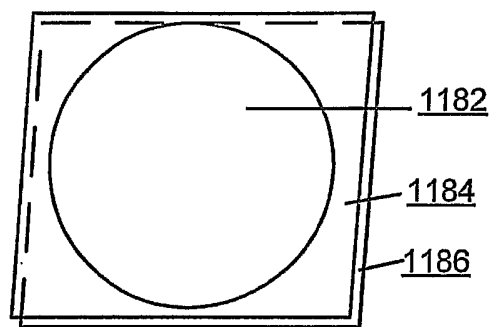

Figure 11A

1190

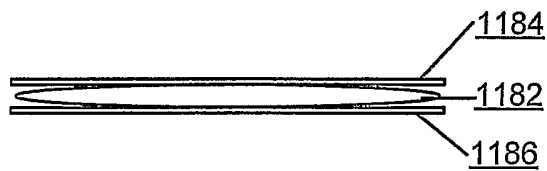

Figure 11B

Figure 12A

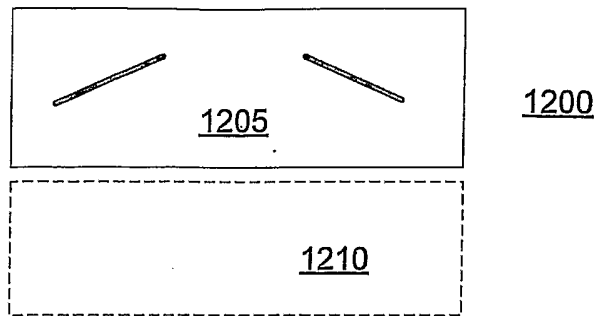

Figure 12B

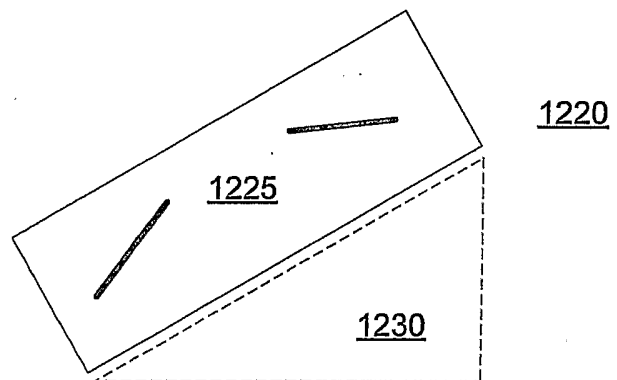
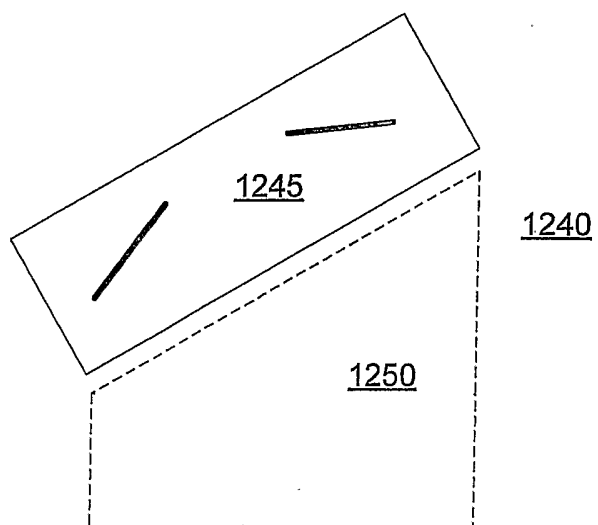

Figure 12C



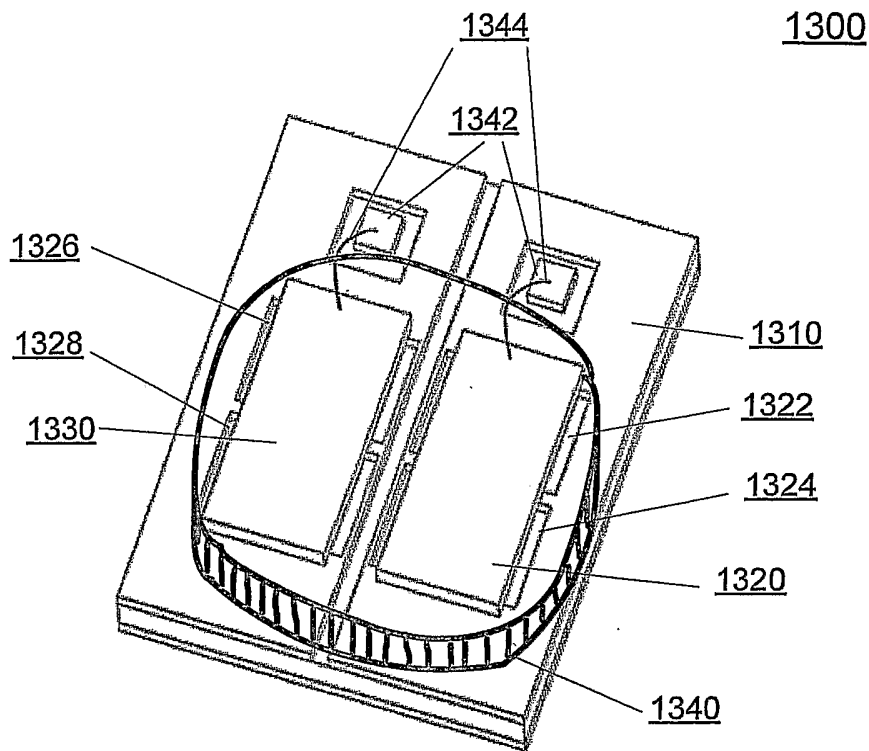

Figure 13A

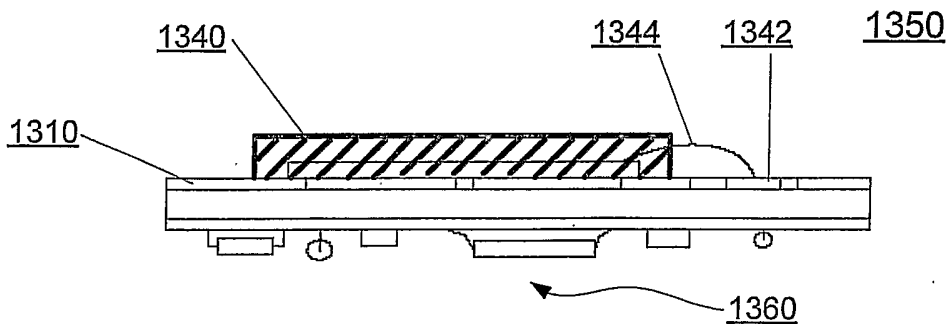

Figure 13B

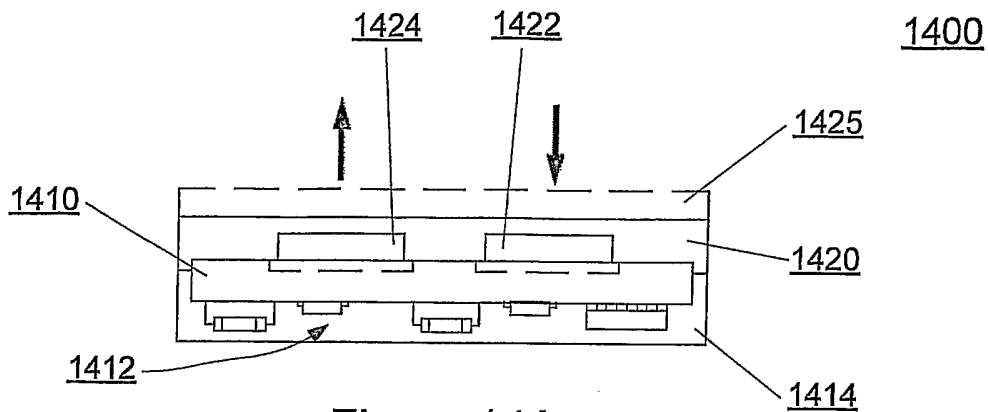

Figure 14A

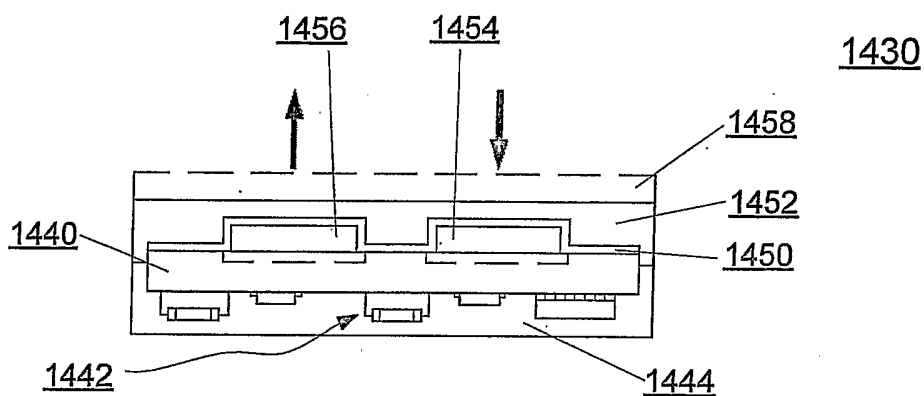

Figure 14B

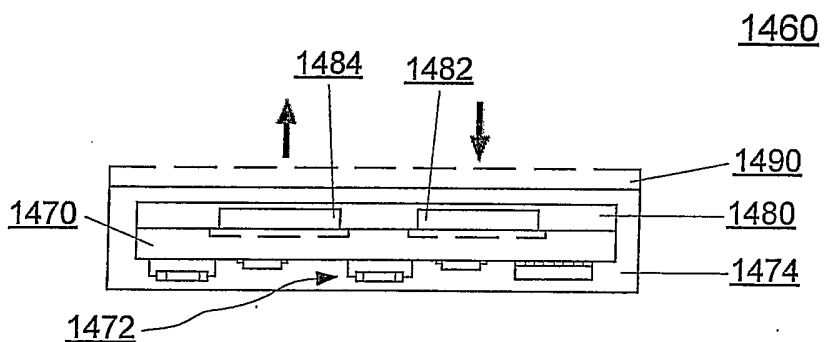

Figure 14C

15/15

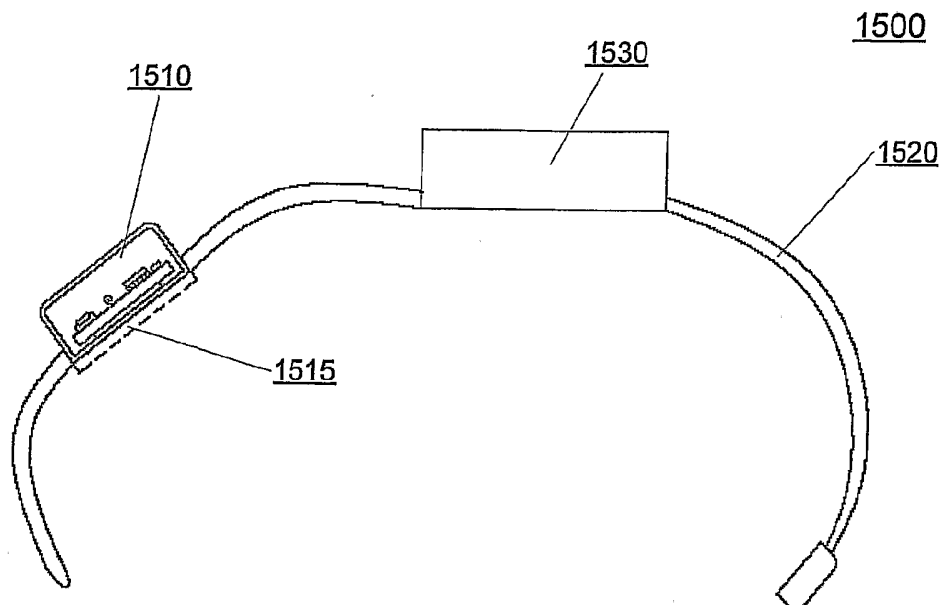

Figure 15A

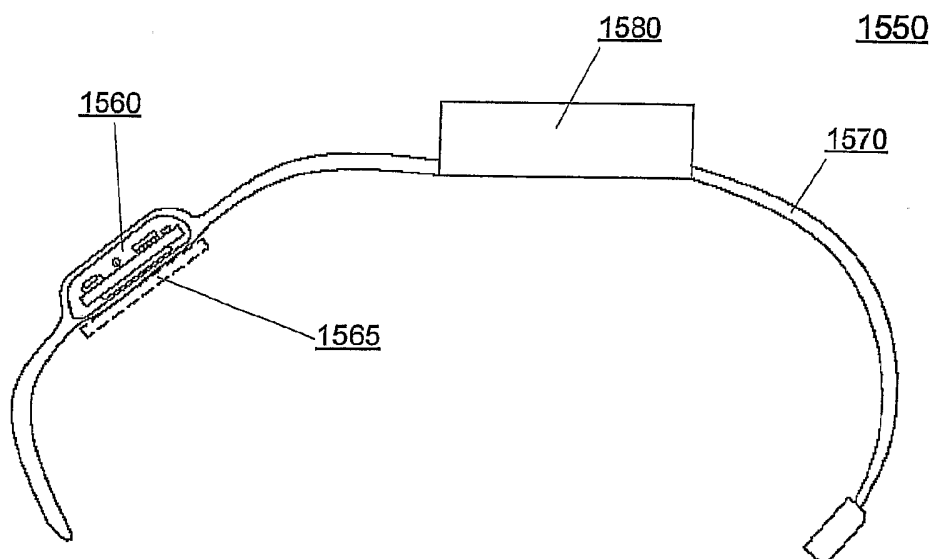

Figure 15B

INTERNATIONAL SEARCH REPORT

PCT/US05/41597

Continuation of B. FIELDS SEARCHED Item 3:

EAST

Search Terms: Air backed/backing, hole, cut-out, printed circuit, circuit board, ultraso\$9, transducer\$1