



- (51) International Patent Classification:
A46B 9/04 (2006.01) A46B 15/00 (2006.01)
- (21) International Application Number:
PCT/US2014/072066
- (22) International Filing Date:
23 December 2014 (23.12.2014)
- (25) Filing Language: English
- (26) Publication Language: English
- (71) Applicant: COLGATE-PALMOLIVE COMPANY
[US/US]; 300 Park Avenue, New York, New York 10022 (US).
- (72) Inventors: JIMENEZ, Eduardo J.; 21 Manor Drive, Manalapan, New Jersey 07726 (US). STORZ, Joachim; Von Goetz Weg 15, 16, A-5700 Zell am See (AT). WECHSLER, Andreas; Alfred-Kubin-Str. 11, A-5700 Zell am See (AT).
- (74) Agents: BELLES, Brian L. et al.; Colgate-Palmolive Company, 909 River Road, Piscataway, New Jersey 08855 (US).

- (81) Designated States (unless otherwise indicated, for every kind of national protection available): AE, AG, AL, AM, AO, AT, AU, AZ, BA, BB, BG, BH, BN, BR, BW, BY, BZ, CA, CH, CL, CN, CO, CR, CU, CZ, DE, DK, DM, DO, DZ, EC, EE, EG, ES, FI, GB, GD, GE, GH, GM, GT, HN, HR, HU, ID, IL, IN, IR, IS, JP, KE, KG, KN, KP, KR, KZ, LA, LC, LK, LR, LS, LU, LY, MA, MD, ME, MG, MK, MN, MW, MX, MY, MZ, NA, NG, NI, NO, NZ, OM, PA, PE, PG, PH, PL, PT, QA, RO, RS, RU, RW, SA, SC, SD, SE, SG, SK, SL, SM, ST, SV, SY, TH, TJ, TM, TN, TR, TT, TZ, UA, UG, US, UZ, VC, VN, ZA, ZM, ZW.
- (84) Designated States (unless otherwise indicated, for every kind of regional protection available): ARIPO (BW, GH, GM, KE, LR, LS, MW, MZ, NA, RW, SD, SL, ST, SZ, TZ, UG, ZM, ZW), Eurasian (AM, AZ, BY, KG, KZ, RU, TJ, TM), European (AL, AT, BE, BG, CH, CY, CZ, DE, DK, EE, ES, FI, FR, GB, GR, HR, HU, IE, IS, IT, LT, LU, LV, MC, MK, MT, NL, NO, PL, PT, RO, RS, SE, SI, SK, SM, TR), OAPI (BF, BJ, CF, CG, CI, CM, GA, GN, GQ, GW, KM, ML, MR, NE, SN, TD, TG).

[Continued on next page]

(54) Title: ORAL CARE IMPLEMENT

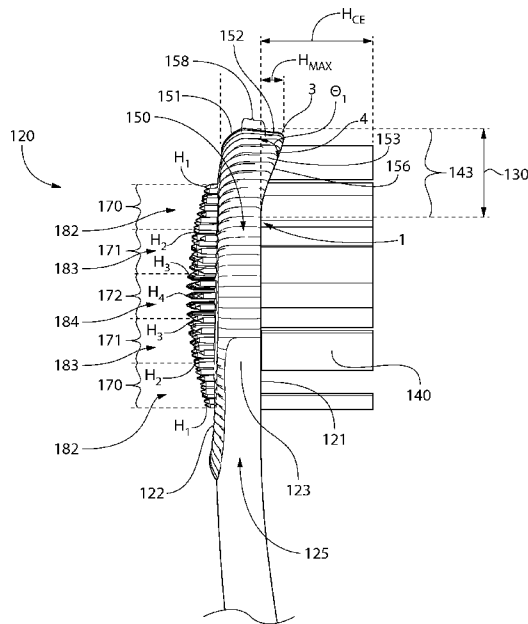

FIG. 5

(57) Abstract: An oral care implement including an elastomeric component that includes a bumper portion that forms a distal-most section of the peripheral surface and a wall portion located along a distal-most section of the perimeter edge and protruding above the front surface. The wall portion may include a first ramped portion, an apex portion, and a second ramped portion. The wall portion may include a plurality of spaced-apart ridges protruding from an outer surface of the bumper portion and an outer surface of the wall portion. An oral care implement is disclosed that includes a soft tissue cleanser having a plurality of protuberances of differing heights.

Published:

— *with international search report (Art. 21(3))*

ORAL CARE IMPLEMENT

BACKGROUND

[0001] A major source of bad breath in healthy people is microbial deposits on the tongue, where a bacterial coating harbors organisms and debris that contribute to bad breath. While oral care implements containing tongue scrapers have been used in the past in order to remove bacteria from the tongue, these oral care implements are inadequate in respect to their effectiveness on the soft tissue surface of the tongue. These oral care implements are also limited in that the tissue cleanser is provided only on one major surface of the head and tend to be small in size and can be ineffective in scraping debris off of the tongue. These oral care implements are further limited in that the oral care implement provides inadequate comfort when contacting the surface of a user's gums during cleaning.

BRIEF SUMMARY

[0002] Exemplary embodiments according to the present disclosure are directed to an oral care implement that includes an elastomeric component that includes a bumper portion that forms a distal-most section of the peripheral surface and a wall portion located along a distal-most section of the perimeter edge and protruding above the front surface. The wall portion may comprise a first ramped portion, an apex portion, and a second ramped portion in certain embodiments. The wall portion may include a plurality of spaced-apart ridges protruding from an outer surface of the bumper portion and an outer surface of the wall portion in certain embodiments. In still other embodiments, an oral care implement is disclosed that includes a soft tissue cleanser having a plurality of protuberances of differing heights.

[0003] In one aspect, the invention can be an oral care implement comprising: a handle and a head extending along a longitudinal axis from a proximal end to a distal end; the head comprising: a front surface, a rear surface opposite the front surface, a peripheral surface extending between the front and rear surfaces and defining a perimeter edge of the front surface, a plurality of tooth cleaning elements extending from the front surface, an elastomeric component including a bumper portion that forms a distal-most section of the peripheral surface and a wall portion located along a distal-most section of the perimeter edge and protruding above the front surface, the wall portion extending along the perimeter edge in a continuous manner

from a first point of the perimeter edge to a second point of the perimeter edge, the first and second points located on opposite sides of the longitudinal axis, the wall portion comprises a first ramped portion, an apex portion, and a second ramped portion, the apex portion disposed between the first and second ramped portions.

[0004] In another aspect, the invention can be an oral care implement comprising: a handle and a head extending along a longitudinal axis from a proximal end to a distal end, the head comprising: a front surface, a rear surface opposite the front surface, a peripheral surface extending between the front and rear surfaces and defining a perimeter edge of the front face, a plurality of tooth cleaning elements extending from the front surface, an integrally formed elastomeric component including: a bumper portion that forms a distal-most section of the peripheral surface, a wall portion located along a distal-most section of the perimeter edge and protruding above the front surface, a plurality of spaced-apart ridges protruding from an outer surface of the bumper portion and an outer surface of the wall portion, and a soft tissue cleanser on the rear surface of the head, the soft tissue cleanser comprising a plurality of protuberances.

[0005] In yet another aspect, the invention can be an oral care implement comprising: a handle and a head extending along a longitudinal axis from a proximal end to a distal end, the head comprising: a front surface, a rear surface, a plurality of tooth cleaning elements extending from the front surface, and a soft tissue cleanser on the rear surface of the head; the soft tissue cleanser comprising: a plurality of first protuberances protruding from the rear surface of the head and arranged in a first annular zone on the rear surface, each of the first plurality of protuberances having a height between a first predetermined height and a second predetermined height, the second predetermined height being greater than the first predetermined height, a plurality of second protuberances protruding from the rear surface of the head and arranged in a second annular zone on the rear surface, the first annular zone surrounding the second annular zone, each of the second plurality of protuberances having a height between the second predetermined height and a third predetermined height, the third predetermined height being greater than the second predetermined height; and a plurality of third protuberances protruding from the rear surface of the head and arranged in a third zone on the rear surface, the second annular zone surrounding the third zone, each of the third plurality of protuberances having a height between the third predetermined height and a fourth predetermined height, the fourth predetermined height being greater than the third predetermined height.

[0006] In still another aspect, the invention can be an oral care implement comprising: a handle, a head extending along a longitudinal axis from a proximal end to a distal end, the head comprising: a front surface, a rear surface, a plurality of tooth cleaning elements extending from the front surface, and a soft tissue cleanser on the rear surface of the head; the soft tissue cleanser comprising: a plurality of cylindrical nubs protruding from the rear surface of the head, wherein free ends of the plurality of protuberances collectively form a convex side profile and a convex top profile.

[0007] In a further aspect, the invention can be an oral care implement comprising: a handle and a head extending along a longitudinal axis from a proximal end to a distal end, the head comprising: a front surface, a rear surface, a plurality of tooth cleaning elements extending from the front surface, and a soft tissue cleanser on the rear surface of the head; the soft tissue cleanser comprising: a plurality of first protuberances protruding from the rear surface of the head, each of the first plurality of protuberances having a height between a first predetermined height and a second predetermined height, the second predetermined height being greater than the first predetermined height; a plurality of second protuberances protruding from the rear surface of the head, each of the second plurality of protuberances having a height between the second predetermined height and a third predetermined height, the third predetermined height being greater than the second predetermined height; and a plurality of third protuberances protruding from the rear surface of the head, each of the third plurality of protuberances having a height between the third predetermined height and a fourth predetermined height, the fourth predetermined height being greater than the third predetermined height.

[0008] Further areas of applicability of the present invention will become apparent from the detailed description provided hereinafter. It should be understood that the detailed description and specific examples, while indicating the preferred embodiment of the invention, are intended for purposes of illustration only and are not intended to limit the scope of the invention.

BRIEF DESCRIPTION OF THE DRAWINGS

[0009] The present invention will become more fully understood from the detailed description and the accompanying drawings, wherein:

[0010] Figure 1 is a front perspective view of an oral care implement according to an embodiment of the present invention;

[0011] Figure 2 is a close-up view of the head of the oral care implement of Figure 1;

[0012] Figure 3 is a front view of the head of the oral care implement of Figure 1;

[0013] Figure 4 is a longitudinal cross-sectional view of the head of the oral care implement of Figure 1 along view IV-IV of Figure 3;

[0014] Figure 5 is a right-side view of the head of the oral care implement of Figure 1;

[0015] Figure 6 is a left-side view of the head of the oral care implement of Figure 1;

[0016] Figure 7 is an enlarged top view of the head of the oral care implement of Figure 1;

[0017] Figure 8 is a rear view of the head of the oral care implement of Figure 1; and

[0018] Figure 9 is a rear perspective view of the head of the oral care implement of Figure 1.

DETAILED DESCRIPTION

[0019] The following description of the preferred embodiment(s) is merely exemplary in nature and is in no way intended to limit the invention, its application, or uses.

[0020] The description of illustrative embodiments according to principles of the present invention is intended to be read in connection with the accompanying drawings, which are to be considered part of the entire written description. In the description of the exemplary embodiments of the invention disclosed herein, any reference to direction or orientation is merely intended for convenience of description and is not intended in any way to limit the scope of the present invention. Relative terms such as “lower,” “upper,” “horizontal,” “vertical,” “above,” “below,” “up,” “down,” “left,” “right,” “top,” “bottom,” “front” and “rear” as well as derivatives thereof (e.g., “horizontally,” “downwardly,” “upwardly,” etc.) should be construed to refer to the orientation as then described or as shown in the drawing under discussion. These relative terms are for convenience of description only and do not require that the apparatus be constructed or operated in a particular orientation unless explicitly indicated as such. Terms such as “attached,” “affixed,” “connected,” “coupled,” “interconnected,” “secured” and similar refer to a relationship wherein structures are secured or attached to one another either directly or indirectly through intervening structures, as well as both movable or rigid attachments or relationships, unless expressly described otherwise. Moreover, the features and benefits of the invention are described by reference to the exemplary embodiments illustrated herein. Accordingly, the invention expressly should not be limited to such exemplary embodiments, even if indicated as being preferred. The discussion herein describes and illustrates some possible non-limiting combinations of features that may exist alone or in other combinations of features. The scope of the invention is defined by the claims appended hereto.

[0021] In the following description, the invention is discussed in terms of a manual toothbrush. However, in other forms, the invention could be in the form of other oral care implements including a soft-tissue cleansing implement, a powered toothbrush, a refill head, or other ansate implements designed for oral care.

[0022] Referring first to Figure 1, an oral care implement 100 is illustrated according to one embodiment of the present invention. The oral care implement 100 generally comprises a handle 110 and a head 120. The handle 110 provides the user with a mechanism by which he/she can readily grip and manipulate the oral care implement 100. The handle 110 is generically illustrated and may be formed of many different shapes, sizes, materials and by a variety of manufacturing methods that are well-known to those skilled in the art. For example, the handle 110 can be constructed of elastomers, polypropylene, SAN, ABS, or even paper products such as a typical lollipop stick. If desired, the handle 110 may include a suitable textured grip (not shown) made of a thermoplastic elastomer or can be a multi-part construction. The details of the handle 110 are not limiting of the present invention and, thus, require no further discussion for purposes of the present invention.

[0023] The oral care implement 100 extends from a proximal end 112 to a distal end 113. The head 120 is operably connected to a distal end of the handle 110. Generally, the head 110 and the handle 120 of the toothbrush are preferably formed as a single unitary structure using a molding, milling, machining or other suitable process. However, in other embodiments, the handle 110 and head 120 may be formed as separate components which are operably connected at a later stage of the manufacturing process by any suitable technique known in the art, including without limitation thermal welding, a tight-fit assembly, a coupling sleeve, adhesion, or fasteners. Whether the head 120 and handle 110 are of a unitary or multi-piece construction (including connection techniques) is not limiting of the present invention unless specifically stated in the claims.

[0024] It should be noted at this time that relative terms such as distal, middle, proximal, upper, lower, top, bottom, left, right etc. are merely used to delineate relative positions of the components of the oral care implement 100 with respect to one another and are not intended to be in any further way limiting of the present invention

[0025] Referring to Figures 2 and 3, the head 120 extends along a longitudinal axis A-A from a proximal end 131 of the head 120 to a distal end 132 of the head 120. The head 120 generally

comprises a front surface 121, a rear surface 122 that is opposite the front surface 121 (as shown in Figure 4) and a peripheral surface 123. The peripheral surface 123 extends between the front surface 121 and the rear surface 122, connecting the front and rear surfaces 121, 122 and defining a perimeter edge 124 of the front surface 121. The front surface 121, the rear surface 122, and the peripheral surface 123 of the head 120 can take on a wide variety of shapes and contours, none of which are limiting of the present invention. For example, the surfaces can be planar, contoured or combinations thereof. Furthermore, while the head 120 is normally widened relative to the neck 111 of the handle 110, it could in some constructions simply be a continuous extension or narrowing of the handle 110.

[0026] Referring to Figures 3-6 concurrently, the head 120 further comprises an elastomeric component 150, which may include a bumper portion 151 that forms a distal-most section 130 of the peripheral surface 123 and a wall portion 152 located along a distal-most section of the perimeter edge 124. The wall portion 152 protrudes above the front surface 121. The wall portion 152 extends along the perimeter edge 124 in a continuous manner from a first point 1 of the perimeter edge 124 to a second point 2 of the perimeter edge 124. The first and second points 1, 2 are located on opposite sides of the longitudinal axis A-A. The wall portion 152 may comprise a first ramped portion 153, a second ramped portion 154, and an apex portion 155 (best visible in Figure 7). The apex portion 155 is disposed between the first ramped position 153 and the second ramped position 154.

[0027] In one embodiment, the first ramped portion 153 may extend from the first point 1 to a fourth point 4 of the perimeter edge 124. The fourth point 4 is located between the first and third points 1, 3. The height of the first ramped portion 153 of the wall portion 152 increases from the first point 1 to the fourth point 4. The second ramped portion 154 may extend from the second point 2 to a fifth point 5 of the perimeter edge 124. The fifth point 5 is located between the second and third points 2, 3. The height of the second ramped portion 154 of the wall portion 152 increases from the second point 2 to the fourth point 5. The apex portion 155 may extend from the fourth point 4 to the fifth point 5. The apex portion 155, in the exemplified embodiment, has a substantially constant height from the fourth point 4 to the fifth point 5.

[0028] The wall portion 152 has a maximum height H_{\max} at the third point 3 of the perimeter edge 124, which is located between the first and second points 1, 2. The third point 3 is located

on the longitudinal axis IV and on the apex portion 155. The wall portion 152 has a substantially zero height at the first and second points 1, 2.

[0029] In another embodiment, the first ramped portion 153 may extend from the first point 1 to the third point 3, wherein the height of the first ramped portion 153 of the wall portion 152 may increase from the first point 1 to the third point 3. The second ramped portion 154 may extend from the second point 2 to the third point 3, wherein the height of the second ramped portion 154 of the wall portion 152 may increase from the second point 2 to the third point 3. In such an embodiment, the apex portion 155 may take the form of a single point, rather than a section.

[0030] The first and second ramped portions 153, 154 may comprise an upper edge 156, 157 that appear as a linear slope when the head is viewed in side profile (see Figures 5 and 6). The first upper edge 156 of the first ramped portion 153 may extend upward from the front surface 121 at an angle of θ_1 and the second upper edge 157 of the second ramped portion 154 may extend upward from the front surface 121 at an angle of θ_2 . The θ_1 and θ_2 may be the same or different and each θ_1 and θ_2 may be selected from an angle ranging from about 10° to about 60° ; preferably from about 15° to about 45° ; and more preferably about 25° to about 35° .

[0031] The wall portion 152 and a transverse line B-B extending between the first and second points 1, 2 of the perimeter edge 124 collectively define a distal-most area 130 of the front surface 121 of the head 120. A remaining portion of the perimeter edge 125 may be free of the wall portion 152. The remaining portion of the perimeter edge 125 may extend from the first point 1 to a sixth point 6 along the perimeter edge 125. The remaining portion of the perimeter edge 125 may also extend from the second point 2 to a seventh point 7 along the perimeter edge 125. In some embodiments, the wall portion 152 is arcuate and comprises a convex inner surface and a concave outer surface. The wall portion 152 may be free of through-holes.

[0032] Referring to Figures 5 and 6, the elastomeric component 150 may further comprise a plurality of spaced-apart ridges 158 protruding from an outer surface of the bumper portion 151 and an outer surface of the wall portion 152. The elastomeric component 150 may also comprise a plurality of spaced-apart ridges 158 protruding from an outer surface along at least a portion of the peripheral surface 123. The elastomeric component 150 may further comprise a soft tissue cleanser 180 on the rear surface 122 of the head 120, the soft tissue cleanser 180 comprising a plurality of protuberances 181. In some embodiments, the elastomeric component 150 may be

an integrally formed component and include the bumper portion 151, the wall portion 152, the plurality of spaced-apart ridges 158, and the soft tissue cleanser 180.

[0033] The soft tissue cleanser 180 is preferably constructed of a biocompatible resilient material suitable for uses in an oral hygiene apparatus, such as a thermoplastic elastomer. As an example, one preferred elastomeric material is styrene-ethylene/butylene-styrene block copolymer (SEBS) manufactured by GLS Corporation. Nevertheless, SEBS material from other manufacturers or other materials. The soft tissue cleanser 180 can be constructed of different types of resilient materials or the same resilient material with one or more different characteristics, such as color, hardness, density, flavor, and/or sensate.

[0034] As shown in Figure 4, the head 120 comprises a base portion 126 formed of a rigid plastic, such as polypropylene. The elastomeric component 150 may be injection molded to the base portion 126. The base portion 126 comprises a peripheral wall 127 that forms a basin 128, the head 120 further comprises a head plate 160 disposed within the basin 128 and coupled to the base portion 126.

[0035] The head plate 160 comprises a plurality of through holes 161. A plurality of cleaning elements 140 are provided that extend through the through holes 161 of the head plate. The plurality of cleaning elements 140 extend from the front surface 121 of the head 120.

[0036] Each of the plurality of cleaning elements 140 comprise a cleaning portion 141 extending from an upper surface 162 of the head plate 160 for cleaning contact with an oral surface. Each of the plurality of cleaning elements 140 also includes a melt portion 142 located between a lower surface of the head plate 163 and a floor of the basin 129. The melt portions 142 anchor the cleaning elements 140 to the head. While the plurality of cleaning elements 140 are particularly suited for brushing teeth, the plurality of cleaning elements 140 can also be used to clean oral soft tissue, such as a tongue, gums, or cheeks instead of or in addition to teeth.

[0037] As used herein, the term "cleaning element" is used in a generic sense to refer to any structure that can be used to clean or massage an oral surface through relative surface contact. Common examples of "cleaning elements" include, without limitation, filament bristles, fiber bristles, nylon bristles, spiral bristles, rubber bristles, elastomeric protrusions, flexible polymer protrusions, combinations thereof and/or structures containing such materials or combinations.

[0038] Referring to Figures 4-7, the plurality of cleaning elements 140 comprises a plurality of distal cleaning elements 143 extending from the distal-most area 130 of the front surface 121.

The maximum height H_{\max} of the wall portion 152 is less than or equal to one half of a height H_{CE} of a shortest one of the plurality of distal tooth cleaning elements 143. In one embodiment, the maximum height H_{\max} of the wall portion 152 is less than or equal to one third of the height H_{CE} of a shortest one of the plurality of distal tooth cleaning elements 143. In another embodiment, the maximum height H_{\max} of the wall portion 152 is less than or equal to one quarter of the height H_{CE} of a shortest one of the plurality of distal tooth cleaning elements 143. The plurality of distal tooth cleaning elements 143 may comprise tapered bristles.

[0039] In some embodiments the peripheral surface 123 may comprise the elastomeric component 150 and the rigid plastic used to form the base portion 126 of the head 120. In another embodiment, the peripheral surface 123 may be entirely formed by the elastomeric component 150.

[0040] With reference to Figures 5-9, the details of the elastomeric component 150 includes the soft tissue cleanser 180, which will now be discussed. The soft tissue cleanser 180 is on the rear surface 122 of the head 120 and comprises a pad 188 that forms at least a portion of the rear surface 122 of the head 120 of the oral care implement 100. The pad 188 is preferably injection molded directly to the head 120 but can be molded separately and later fixed to the head 120 if desired, for example by an adhesive or sonic welding. The pad 188 extends from a distal end 132 of the head 120 to a proximal end 131 of the head 120 and may cover substantially the entire width of the head 120, extending from a first lateral edge 133 of the head 120 towards a second lateral edge 134 of the head 120.

[0041] The elastomeric component 150 may have one or more exposed underlying head portions 189 extending therethrough exposing the base portion 126. The exposed underlying head portions 189 may be a variety of geometric shapes – such as circular or crescent shapes. In one embodiment, the exposed underlying head portions 189 define a boundary for which a plurality of protuberances 181 are positioned on the rear surface 122 of the head 120. In one embodiment, crescent shaped exposed underlying head portions 189 define an annular shaped layout of the plurality of protuberances 181 when looking at the rear surface 122 of the head 120.

[0042] The pad 188 includes an exposed top surface 190 on the rear surface 122 of the head. The plurality of protuberances 181 protrude from the rear surface 122 of the head 120 from the top surface 190 of the pad 188. The plurality of protuberances 181 may include a first plurality of protuberances 182 arranged in a first annular zone 170 on the rear surface 122. The first

annular zone 170 is the area defined between a first dotted line 173 and a second dotted line 174. Each of the first plurality of protuberances 182 may have a height between a first predetermined height H_1 and a second predetermined height H_2 , the second predetermined height H_2 being greater than the first predetermined height H_1 .

[0043] The plurality of protuberances 181 may further include a plurality of second protuberances 183 protruding from the rear surface 122 of the head 120 and arranged in a second annular zone 171 on the rear surface 122. The first annular zone 170 surrounds the second annular zone 171. The second annular zone 171 is the area defined between the second dotted line 174 and a third dotted line 175. Each of the second plurality of protuberances 183 may have a height between the second predetermined height H_2 and a third predetermined height H_3 , the third predetermined height H_3 being greater than the second predetermined height H_2 .

[0044] The plurality of protuberances 181 may further include a plurality of third protuberances 184 protruding from the rear surface 122 of the head 120 and arranged in a third zone 172 on the rear surface 122. The second annular zone 171 surrounds the third annular zone 173. The third zone 172 may be annular zone or it may be a central zone. The third annular zone 172 is the area defined within the third dotted line 175. Each of the third plurality of protuberances 184 have a height between the third predetermined height H_3 and a fourth predetermined height H_4 , the fourth predetermined height H_4 being greater than the third predetermined height H_3 .

[0045] In some embodiments, the plurality of first protuberances 182 may comprise protuberances having a plurality of different heights between the first and second predetermined heights H_1 , H_2 . The plurality of second protuberances 183 may comprise protuberances having a plurality of different heights between the second and third predetermined heights H_2 , H_3 . The plurality of third protuberances 184 may comprises protuberances having a plurality of different heights between the third and fourth predetermined heights H_3 , H_4 .

[0046] In certain embodiments, the plurality of first protuberances 182 consist only of protuberances having a height between the first and second predetermined heights H_1 , H_2 . The plurality of second protuberances 183 consist only of protuberances having a height between the second and third predetermined heights H_2 , H_3 . The plurality of third protuberances 184 consist only of protuberances having a height between the third and fourth predetermined heights H_3 , H_4 .

[0047] The first predetermined height H_1 may be in a range of 0.5 mm to 1.5 mm, the second predetermined height H_2 may be in a range of 1.5 mm to 2.5 mm, the third predetermined height

H₃ may be in a range of 2.5 mm to 3.5 mm, and the fourth predetermined height H₄ may be in a range of 3.5 mm to 6.0 mm.

[0048] In some embodiments, free ends of the first, second and third protuberances 182, 183, 184 collectively form a convex side profile (see Figures 5 and 6). In some embodiments, the free ends of the first, second and third protuberances 182, 183, 184 may also collectively form a convex top profile (see Figures 7).

[0049] The plurality of first protuberances 182 comprises first conical nubs, the plurality of second protuberances 183 comprises second conical nubs, and the plurality of third protuberances 184 comprises third conical nubs. In one embodiment, the plurality of first protuberances 182 consists only of the first conical nubs, the plurality of second protuberances 183 consists only of second conical nubs, and the plurality of third protuberances 184 consists only of the third conical nubs. The plurality of conical nubs extends from the pad portion 188.

[0050] As used herein a "nub" is generally meant to include a column-like protrusion (without limitation to the cross-sectional shape of the protrusion) which is upstanding from a base surface. In a general sense, the nub, in the preferred construction, has a height that is greater than the width at the base of the nub (as measured in the longest direction). Nevertheless, nubs could include projections wherein the widths and heights are roughly the same or wherein the heights are somewhat smaller than the base widths. Moreover, in some circumstances (e.g., where the nub tapers to a tip or includes a base portion that narrows to a smaller projection), the base width can be substantially larger than the height.

[0051] The first, second, and third plurality of nubs 182-184 are designed to engage the oral soft tissue to significantly reduce a major source of bad breath in people and improve hygiene. The first, second, and third plurality of nubs 182-184 enable removal of microflora and other debris from the tongue and other soft tissue surfaces within the mouth. The tongue, in particular, is prone to develop bacterial coatings that are known to harbor organisms and debris that can contribute to bad breath. This microflora can be found in the recesses between the papillae on most of the tongue's upper surface as well as along other soft tissue surfaces in the mouth. When engaged or otherwise pulled against a tongue surface, for example, the first, second, and third nubs provide for gentle engagement with the soft tissue while reaching downward into the recesses of adjacent papillae of the tongue. The elastomeric construction of the soft tissue cleanser 180 also enables a top surface 190 of the pad 188 to follow the natural contours of the

oral tissue surfaces, such as the tongue, cheeks, lips, and gums of a user. Moreover, the first, second, and third nubs are able to flex as needed to traverse and clean the soft tissue surfaces in the mouth along which it is moved.

[0052] In the illustrated embodiment, the first, second, and third nubs are preferably conically shaped. As used herein, "conically shaped" or "conical" is meant to include true cones, frusto-conically shaped elements, and other shapes that taper to a narrow end and thereby resemble a cone irrespective of whether they are uniform, continuous in their taper, or have rounded cross-sections. The base portion of each the conically shaped first, second, and third nubs 182-184 is larger than the corresponding tip portion.

[0053] Furthermore, the resilient material of the first, second, and/or third annular zones 170, 171, 172 may also be imbued with a sensory material, which can be any suitable biocompatible medication or chemical for oral use. The sensory material is released inside the mouth, lips, or cheeks by way of several methods, including but not limited to abrasion, a temperature change, a change in pH or dissolution. In one embodiment, the sensory material is a sensate that provides a biochemical sensory response to the inside tissue and surfaces of the mouth. Such a sensory response is understood to result from stimulation of the trigeminal nerve of a human. A sensate generally produces a physiological effect without a taste, with such effect usually represented by the terms cooling, tingle, and hot (or heat). Sensates are usually derived from single compounds that are not volatile and that do not have a smell or taste per se. As one example, a chemical known as capsaicin, found naturally in chile peppers, can be used to provide a tingle, a hot or warm massage, or a heating or warm, soothing sensation to a user. Capsaicin is also known to provide pain relief and numbing sensations when topically applied. Some examples of sensates that produce cooling sensations include (-)-menthol and camphor. Most of the polyols, including maltitol syrup, sorbitol, mannitol, erythritol, isomalt and xylitol, also provide a cooling sensation. The coolest of the polyols, erythritol, provides a distinct cooling sensation. Both erythritol and xylitol cool the mouth and fight the sensation of dry mouth commonly associated with prescription drugs and dental hygiene products. Erythritol is a naturally occurring four-carbon structure. Xylitol is a five-carbon sugar found in fruits and vegetables and made in small amounts by the human system as a metabolic intermediate.

[0054] In another embodiment, the sensory material is provided as flavoring agent for causing an olfactory sensory response in a human. A flavor agent is commonly understood to include a

mixture of compounds that are volatile and produce an aromatic effect and that stimulate the olfactory bulb. Flavors are generally transmitted through the nasal passages, and are often selected and used for their unique association with certain consumer benefits, such as lavender for stress relief or relaxation. Another flavor example is chamomile, which has a strong, aromatic smell and is often used medicinally against sore stomach and as a relaxant to help you fall asleep. Chamomile is also used as a mouthwash against oral mucositis (the swelling, irritation, and ulceration of the mucosal cells that line the digestive tract).

[0055] In one embodiment, the first, second, and/or third annular zone 170, 171, 172 can be imbued with both a sensate component and a flavor component. The soft tissue cleanser 180 may be an integrally formed singular component.

[0056] Referring now to FIGS. 6-8 concurrently, one preferred embodiment of manufacturing the head 120 via an injection molding process will be described. First, the head 120 is formed by injecting a liquefied hard plastic, such as PP or SAN, into a mold having the appropriately shaped fill cavity. Once the head 120 is sufficiently cooled (the structure of which is described above), an outer mold is placed about the head 120 for forming the elastomeric component 150. The elastomeric component 150 is formed by an overmolding process which involves injecting a single shot of a first type of liquefied thermoplastic elastomer about the head 122 via a first port having a first size. The first type of liquefied thermoplastic elastomer surrounds the head 120 and fills available gaps/grooves on the head 120. As a result, the elastomeric component 150 is formed as illustrated. The elastomeric component 150 may also be made using separate shots, each using different types of thermoplastic elastomer, to form different components of the elastomeric component 150 – for example one shot for the pad 188 and another shot for the plurality of protuberances 181. This allows the pad 188 and the plurality of protuberances 181 to be formed of different types of elastomers, which may be useful for elastomeric components 150 having differing colors, flavors, sensates or material properties, such as hardness or density.

[0057] Another embodiment of manufacturing the head 120 includes the head plate 160 which clusters of the plurality of cleaning elements 140 are inserted through the through holes 161. The rear ends of the plurality of cleaning elements 140 are melted thereby affixing the plurality of cleaning elements 140 to the head plate 160. The melted portions form the melt portion 142 that adheres to the head plate 160 and bonds the plurality of cleaning elements 140 to each other.

[0058] As used throughout, ranges are used as shorthand for describing each and every value that is within the range. Any value within the range can be selected as the terminus of the range. In addition, all references cited herein are hereby incorporated by referenced in their entireties. In the event of a conflict in a definition in the present disclosure and that of a cited reference, the present disclosure controls.

[0059] While the invention has been described with respect to specific examples including presently preferred modes of carrying out the invention, those skilled in the art will appreciate that there are numerous variations and permutations of the above described systems and techniques. It is to be understood that other embodiments may be utilized and structural and functional modifications may be made without departing from the scope of the present invention. Thus, the spirit and scope of the invention should be construed broadly as set forth in the appended claims.

CLAIMS

WHAT IS CLAIMED IS:

1. An oral care implement comprising:
 - a handle; and
 - a head extending along a longitudinal axis from a proximal end to a distal end, the head comprising:
 - a front surface;
 - a rear surface opposite the front surface;
 - a peripheral surface extending between the front and rear surfaces and defining a perimeter edge of the front surface;
 - a plurality of tooth cleaning elements extending from the front surface;
 - an elastomeric component including a bumper portion that forms a distal-most section of the peripheral surface and a wall portion located along a distal-most section of the perimeter edge and protruding above the front surface;
 - the wall portion extending along the perimeter edge in a continuous manner from a first point of the perimeter edge to a second point of the perimeter edge, the first and second points located on opposite sides of the longitudinal axis; and
 - the wall portion comprises a first ramped portion, an apex portion, and a second ramped portion, the apex portion disposed between the first and second ramped portions.
2. The oral care implement according to claim 1 wherein the wall portion has a maximum height at a third point of the perimeter edge located between the first and second points, the third point located on the longitudinal axis and on the apex portion.
3. The oral care implement according to claim 2 further comprising:
 - the first ramped portion extending from the first point to a fourth point of the perimeter edge, the fourth point located between the first and third points, the height of the first ramped portion of the wall portion increasing from the first point to the fourth point; and

the second ramped portion extending from the second point to a fifth point of the perimeter edge, the fifth point located between the second and third points, the height of the second ramped portion of the wall portion increasing from the second point to the fifth point.

4. The oral care implement according to claim 3 further comprising:

the apex portion extending from the fourth point to the fifth point, the apex portion having a substantially constant height from the fourth point to the fifth point.

5. The oral care implement according to claim 2 further comprising:

the first ramped portion extending from the first point to the third point, the height of the first ramped portion of the wall portion increasing from the first point to the third point; and

the second ramped portion extending from the second point to the third point, the height of the second ramped portion of the wall portion increasing from the second point to the third point.

6. The oral care implement according to any one of claims 1 to 5 wherein each of the first and second ramped portions comprise an upper edge that appear as a linear slope when the head is viewed in side profile.
7. The oral care implement according to any one of claims 1 to 4 wherein a remaining portion of the perimeter edge is free of the wall portion.
8. The oral care implement according to any one of claims 1 to 5 wherein the wall portion is arcuate and comprises a convex inner surface and a concave outer surface.
9. The oral care implement according to any one of claims 1 to 6 wherein the wall portion is free of through-holes.
10. The oral care implement according to any one of claims 1 to 7 wherein elastomeric component further comprises a plurality of spaced-apart ridges protruding from an outer surface of the bumper portion and an outer surface of the wall portion.

11. The oral care implement according to any one of claims 1 to 8 wherein the elastomeric component further comprises a soft tissue cleanser on the rear surface of the head, the soft tissue cleanser comprising a plurality of protuberances.
12. The oral care implement according to any one of claims 1 to 9 wherein the head comprises a base portion formed of a rigid plastic, the elastomeric component injection molded to the base portion.
13. The oral care implement according to claim 10 wherein the base portion comprises a peripheral wall that forms a basin, the head further comprising a head plate disposed within the basin and coupled to the base portion, the head plate comprising a plurality of through holes, the plurality of cleaning elements extending through the through holes, each of the plurality of cleaning elements comprising a cleaning portion extending from an upper surface of the head plate and a melt portion located between a lower surface of the head plate and a floor of the basin.
14. The oral care implement according to any one of claims 1 and 3 to 13 wherein the wall portion and a transverse line drawn between the first and second points of the perimeter edge collectively define a distal-most area of the front surface of the head; and wherein the plurality of tooth cleaning elements comprises a plurality of distal tooth cleaning elements extending from the distal-most area of the front surface.
15. The oral care implement according to claim 14 wherein the wall portion has a maximum height that is less than or equal to one half of a height of a shortest one of the plurality of distal tooth cleaning elements.
16. The oral care implement according to any one of claims 14 to 15 wherein the plurality of distal tooth cleaning elements comprises tapered bristles.
17. The oral care implement according to any one of claims 1 to 16 wherein the wall portion has a substantially zero height at the first and second points.
18. The oral care implement according to any one of claims 1 to 17 wherein the elastomeric component is an integrally formed single component.
19. An oral care implement comprising:
 - a handle; and

a head extending along a longitudinal axis from a proximal end to a distal end, the head comprising:

a front surface;

a rear surface opposite the front surface;

a peripheral surface extending between the front and rear surfaces and defining a perimeter edge of the front face;

a plurality of tooth cleaning elements extending from the front surface;

an integrally formed elastomeric component including:

a bumper portion that forms a distal-most section of the peripheral surface;

a wall portion located along a distal-most section of the perimeter edge and protruding above the front surface;

a plurality of spaced-apart ridges protruding from an outer surface of the bumper portion and an outer surface of the wall portion; and

a soft tissue cleanser on the rear surface of the head, the soft tissue cleanser comprising a plurality of protuberances.

20. The oral care implement according to claim 19 wherein the wall portion extends along the perimeter edge in a continuous manner from a first point of the perimeter edge to a second point of the perimeter edge, the first and second points located on opposite sides of the longitudinal axis; and wherein the wall portion has a maximum height at a third point of the perimeter edge located between the first and second points, the third point located on the longitudinal axis and on the apex portion.
21. The oral care implement according to any one of claims 19 to 20 wherein the wall portion is free of through-holes.
22. The oral care implement according to any one of claims 19 to 21 wherein the head comprises a base portion formed of a rigid plastic, the elastomeric component injection molded to the base portion.
23. The oral care implement according to any one of claims 19 to 22 wherein the wall portion and a transverse line drawn between the first and second points of the perimeter edge

collectively define a distal-most area of the front surface of the head; and wherein the plurality of tooth cleaning elements comprises a plurality of distal tooth cleaning elements extending from the distal-most area of the front surface; and wherein the wall portion has a maximum height that is less than or equal to one half of a height of a shortest one of the plurality of distal tooth cleaning elements.

24. The oral care implement according to any one of claims 19 to 23 wherein the wall portion has a substantially zero height at the first and second points.

25. An oral care implement comprising:

a handle; and

a head extending along a longitudinal axis from a proximal end to a distal end, the head comprising:

a front surface;

a rear surface;

a plurality of tooth cleaning elements extending from the front surface; and

a soft tissue cleanser on the rear surface of the head;

the soft tissue cleanser comprising:

a plurality of first protuberances protruding from the rear surface of the head and arranged in a first annular zone on the rear surface, each of the first plurality of protuberances having a height between a first predetermined height and a second predetermined height, the second predetermined height being greater than the first predetermined height;

a plurality of second protuberances protruding from the rear surface of the head and arranged in a second annular zone on the rear surface, the first annular zone surrounding the second annular zone, each of the second plurality of protuberances having a height between the second predetermined height and a third predetermined height, the third predetermined height being greater than the second predetermined height; and

a plurality of third protuberances protruding from the rear surface of the head and arranged in a third zone on the rear surface, the second annular zone surrounding the third zone, each of the third plurality of protuberances having a height between the third predetermined height and a fourth predetermined height, the fourth predetermined height being greater than the third predetermined height.

26. The oral care implement according to claim 25 wherein free ends of the first, second and third protuberances collectively form a convex side profile.
27. The oral care implement according to claim 26 wherein free ends of the first, second and third protuberances collectively form a convex top profile.
28. The oral care implement according to any one of claims 25 to 27 wherein the plurality of first protuberances comprise first conical nubs, the plurality of second protuberances comprise second conical nubs, and the plurality of third protuberances comprise third conical nubs.
29. The oral care implement according to claim 28 wherein the plurality of first protuberances consists only of the first conical nubs, the plurality of second protuberances consists only of second conical nubs, and the plurality of third protuberances consists only of the third conical nubs.
30. The oral care implement according to any one of claims 25 to 29 wherein the plurality of first protuberances comprise protuberances having a plurality of different heights between the first and second predetermined heights; wherein the plurality of second protuberances comprise protuberances having a plurality of different heights between the second and third predetermined heights; and wherein the plurality of third protuberances comprise protuberances having a plurality of different heights between the third and fourth predetermined heights.
31. The oral care implement according to any one of claims 25 to 30 wherein the plurality of first protuberances consist only of protuberances having a height between the first and second predetermined heights; wherein the plurality of second protuberances consist only of protuberances having a height between the second and third predetermined heights;

- and wherein the plurality of third protuberances consist only of protuberances having a height between the third and fourth predetermined heights
32. The oral care implement according to any one of claims 25 to 31 wherein the first predetermined height is in a range 0.5 to 1.5 mm, the second predetermined height is in a range of 1.0 mm to 2.5 mm, the third predetermined height is in a range of 2.5 mm to 3.5 mm, and the fourth predetermined height is in a range of 3.5 mm to 6.0 mm.
33. The oral care implement according to any one of claims 25 to 32 wherein the soft tissue cleanser on the rear surface of the head comprises a pad portion that forms at least a portion of the rear surface of the head, the first, second and third pluralities of protuberances extending from the pad portion.
34. The oral care implement according to any one of claims 25 to 32 wherein the soft tissue cleanser is an integrally formed singular component.
35. An oral care implement comprising:
- a handle; and
 - a head extending along a longitudinal axis from a proximal end to a distal end, the head comprising:
 - a front surface;
 - a rear surface;
 - a plurality of tooth cleaning elements extending from the front surface; and
 - a soft tissue cleanser on the rear surface of the head;
- the soft tissue cleanser comprising:
- a plurality of cylindrical nubs protruding from the rear surface of the head;
 - wherein free ends of the plurality of protuberances collectively form a convex side profile and a convex top profile.
36. The oral care implement according to claim 35 wherein the plurality of cylindrical nubs comprises cylindrical nubs having a height greater than or equal to 3.5 mm.

37. The oral care implement according to any one of claims 35 to 36 wherein the soft tissue cleanser comprises a pad portion that forms at least a portion of the rear surface of the head, the plurality of cylindrical nubs extending from the pad portion.
38. The oral care implement according to any one of claims 25 to 32 wherein the soft tissue cleanser is an integrally formed singular component.
39. An oral care implement comprising:
- a handle; and
 - a head extending along a longitudinal axis from a proximal end to a distal end, the head comprising:
 - a front surface;
 - a rear surface;
 - a plurality of tooth cleaning elements extending from the front surface; and
 - a soft tissue cleanser on the rear surface of the head;
- the soft tissue cleanser comprising:
- a plurality of first protuberances protruding from the rear surface of the head, each of the first plurality of protuberances having a height between a first predetermined height and a second predetermined height, the second predetermined height being greater than the first predetermined height;
 - a plurality of second protuberances protruding from the rear surface of the head, each of the second plurality of protuberances having a height between the second predetermined height and a third predetermined height, the third predetermined height being greater than the second predetermined height; and
 - a plurality of third protuberances protruding from the rear surface of the head, each of the third plurality of protuberances having a height between the third predetermined height and a fourth predetermined height, the fourth predetermined height being greater than the third predetermined height.

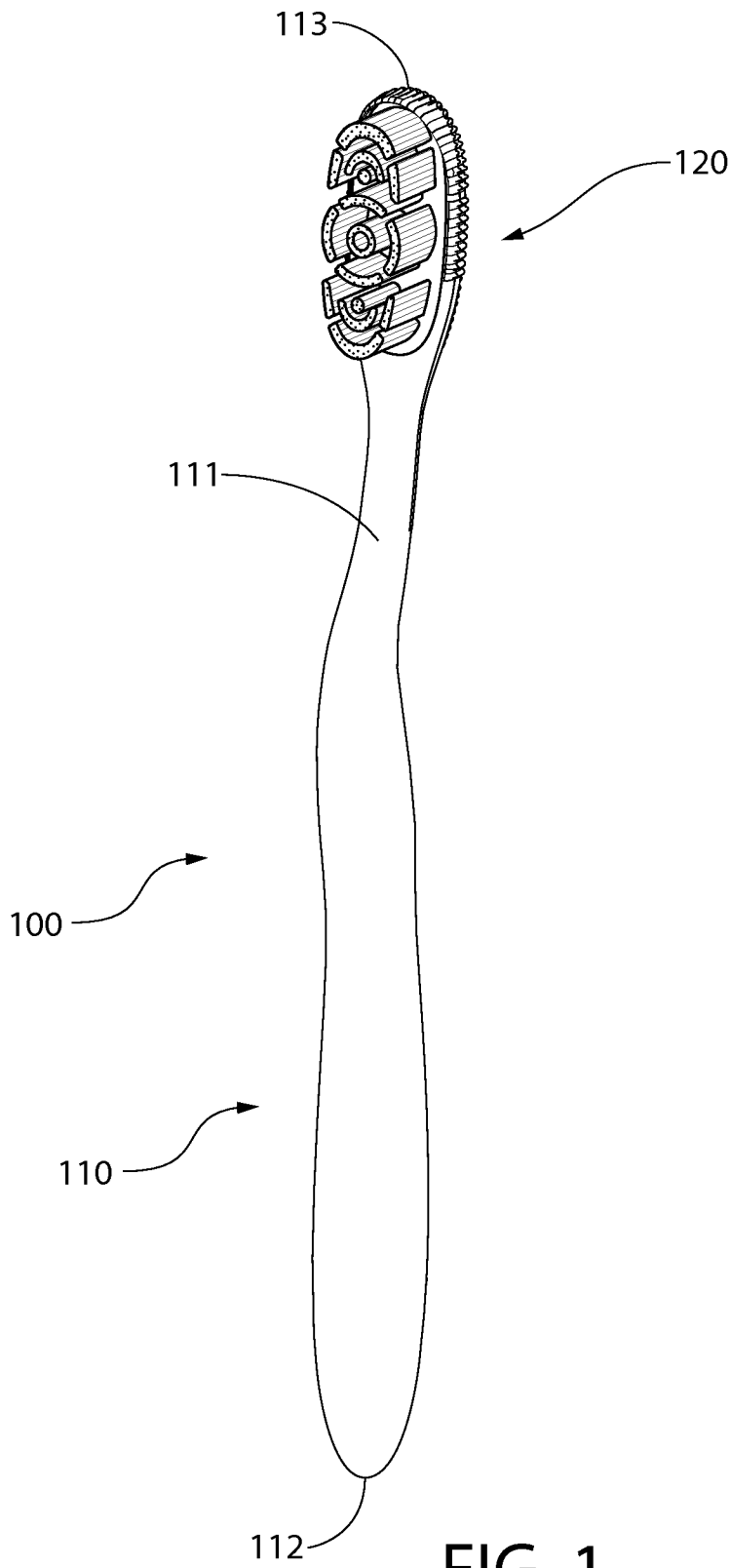

FIG. 1

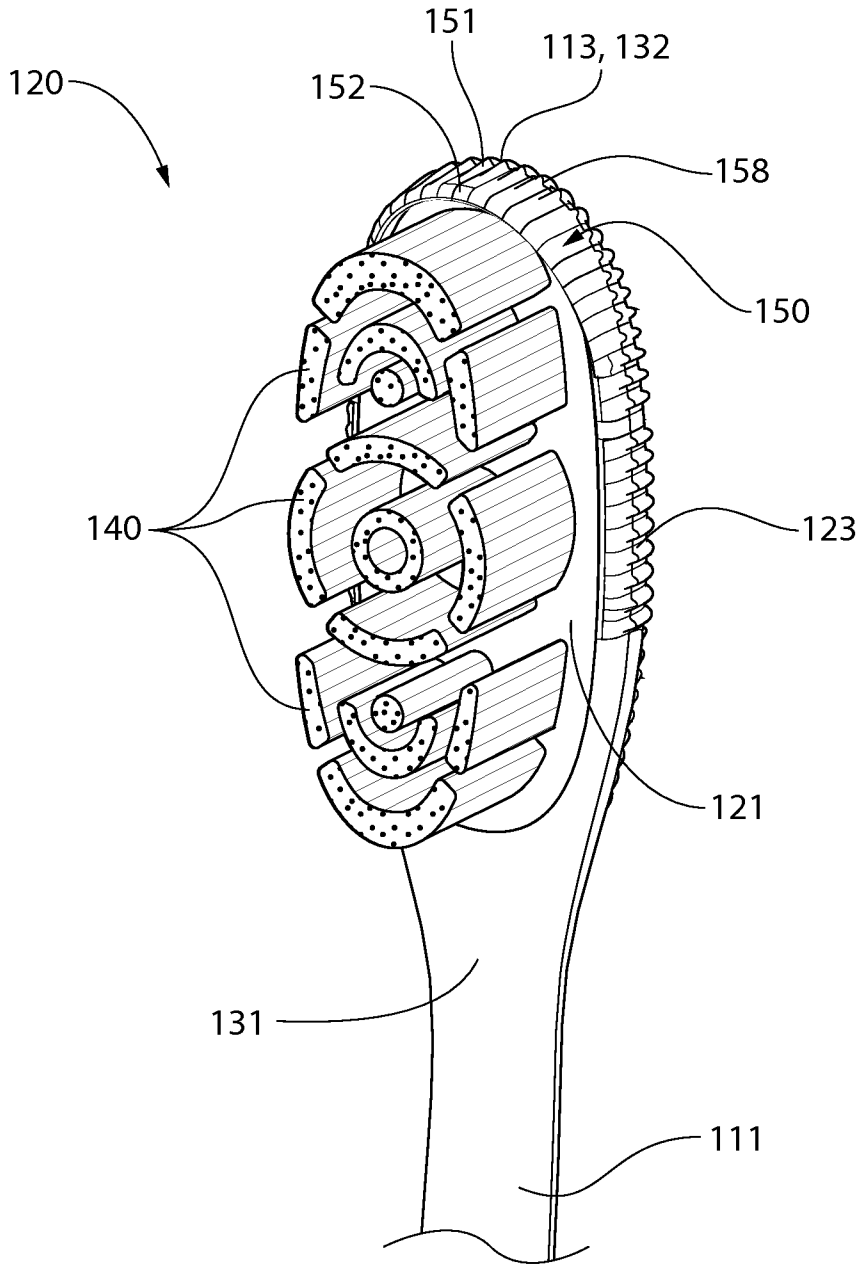

FIG. 2

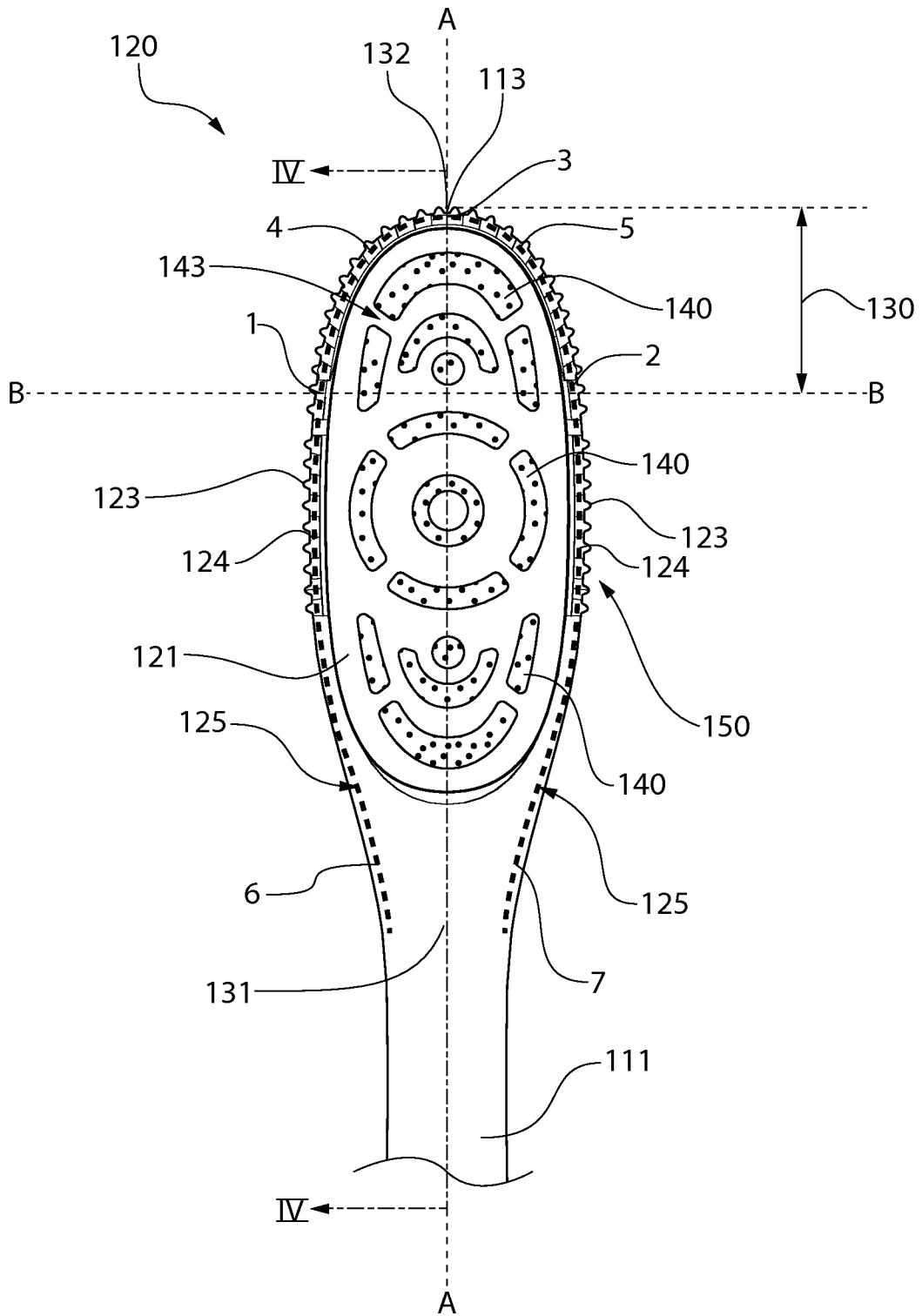

FIG. 3

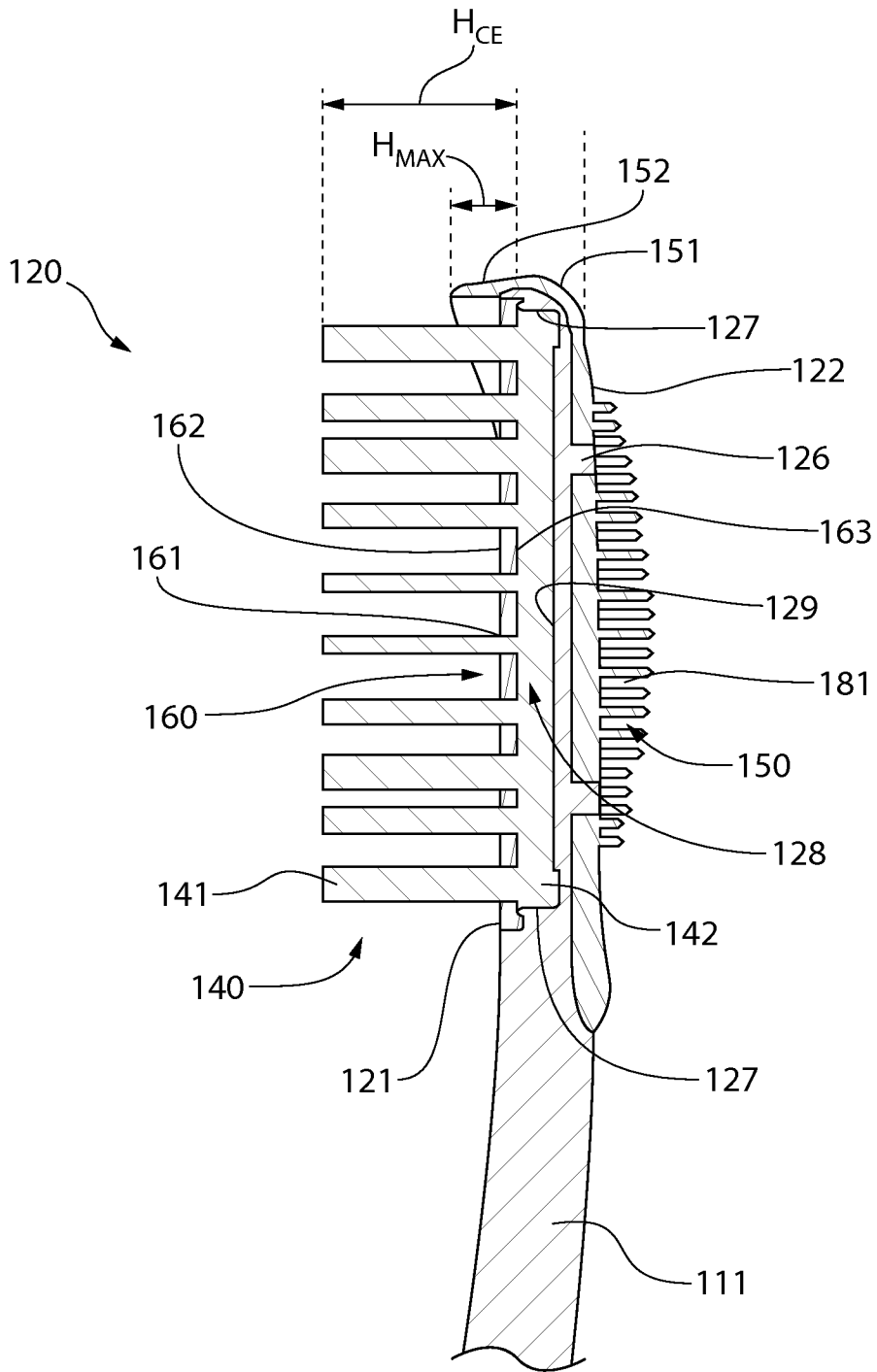

FIG. 4

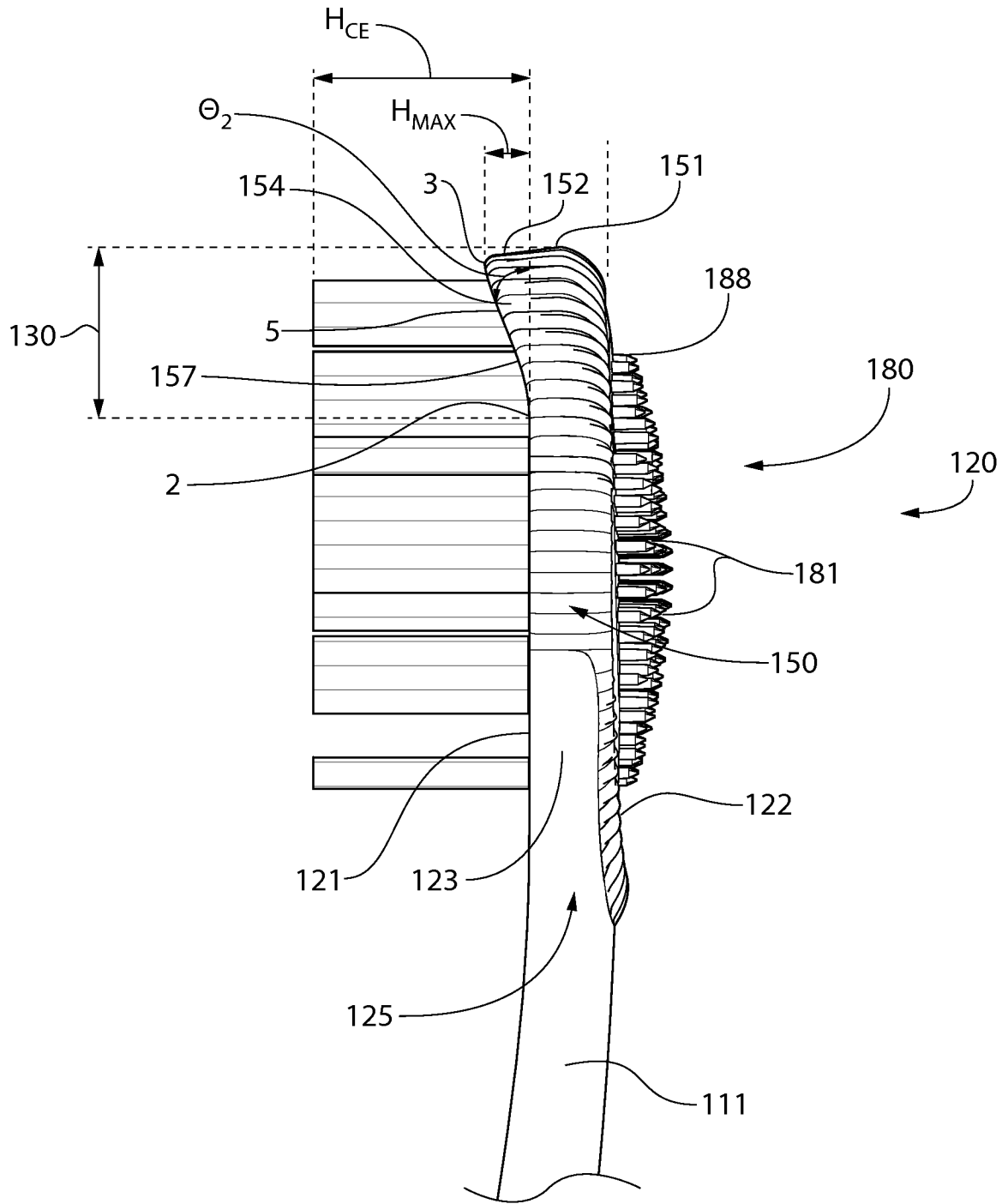

FIG. 6

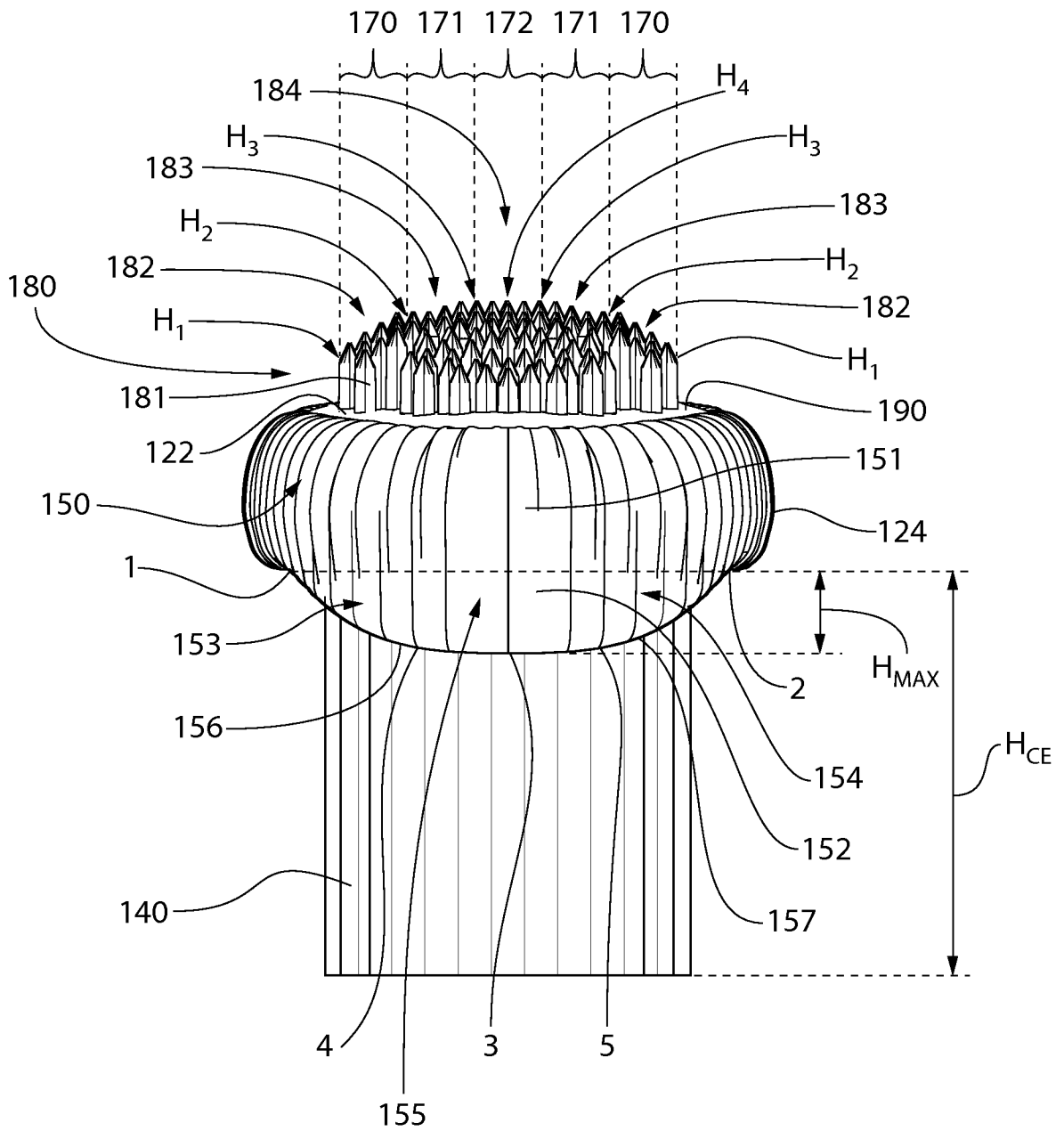

FIG. 7

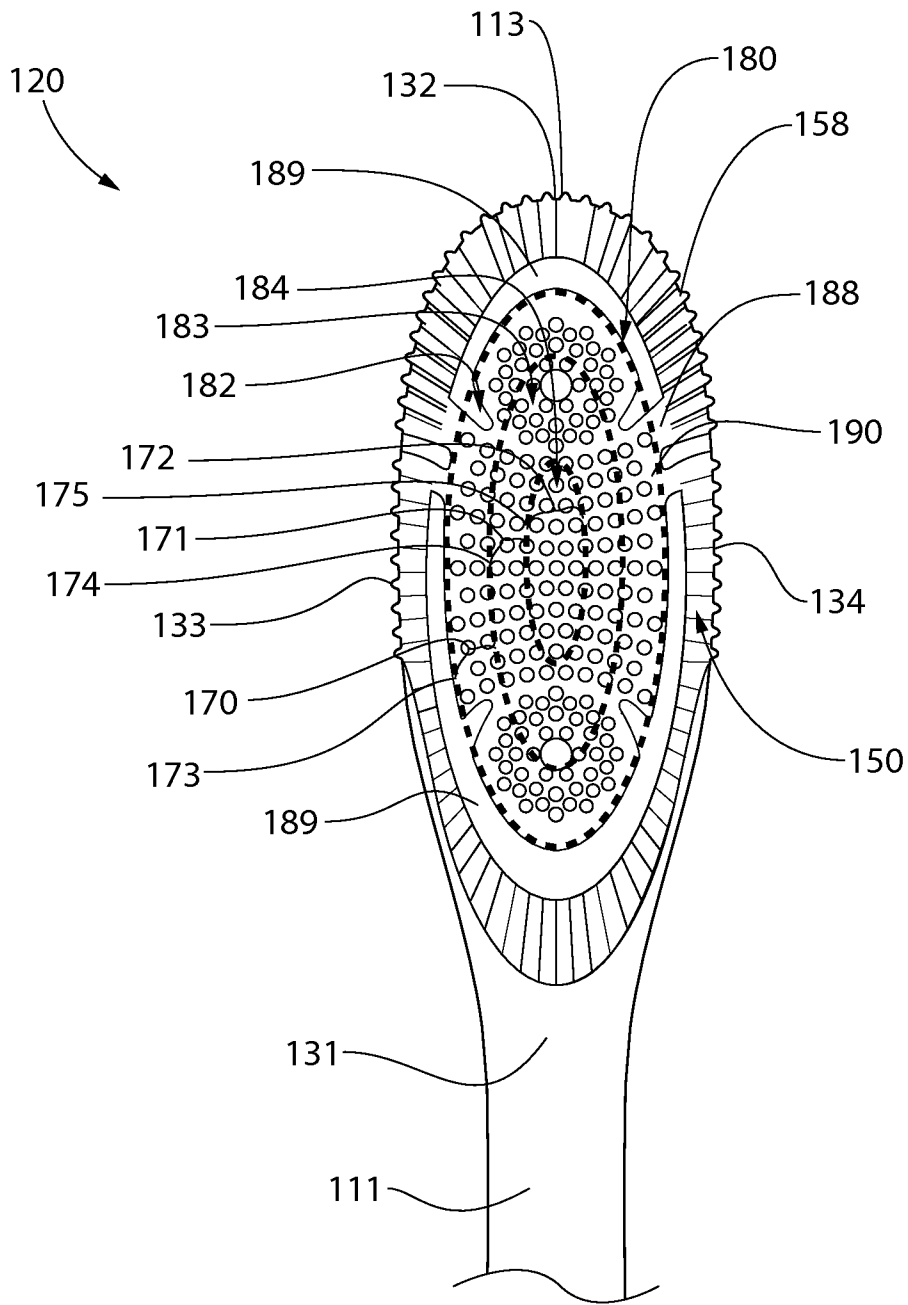

FIG. 8

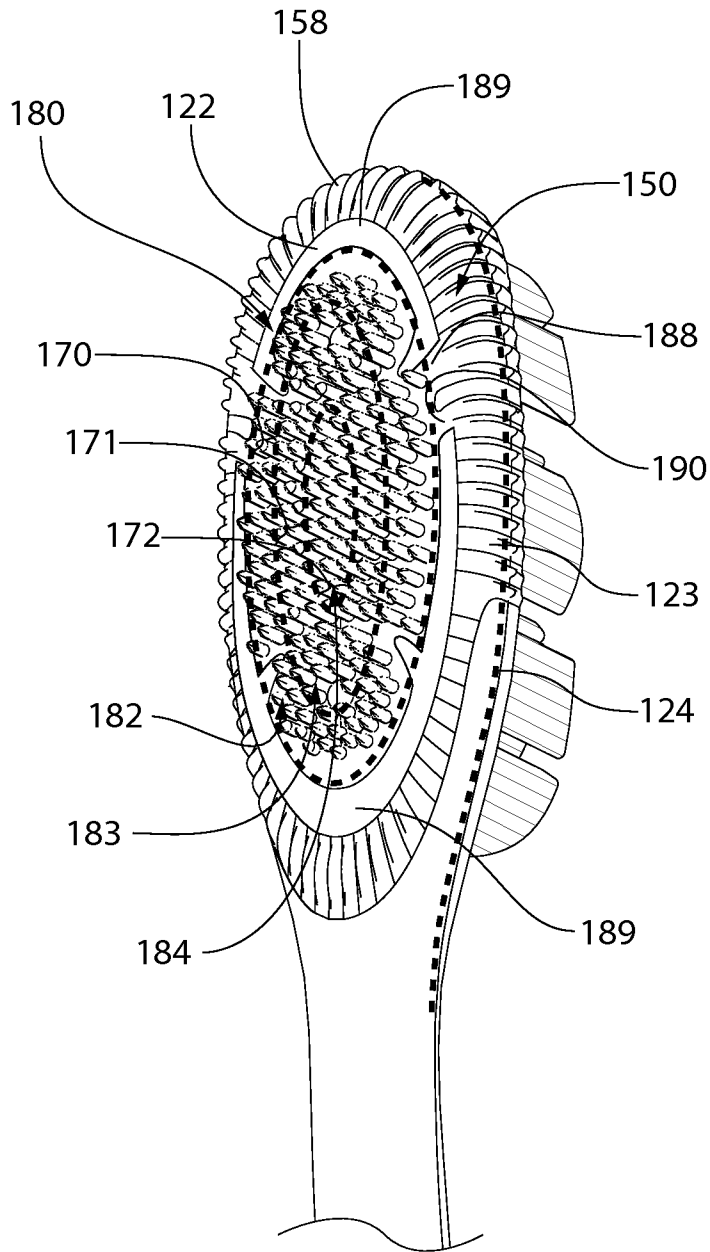

FIG. 9

INTERNATIONAL SEARCH REPORT

International application No
PCT/US2014/072066

A. CLASSIFICATION OF SUBJECT MATTER
INV. A46B9/04 A46B15/00
ADD.
According to International Patent Classification (IPC) or to both national classification and IPC

B. FIELDS SEARCHED
Minimum documentation searched (classification system followed by classification symbols)
A46B A61B
Documentation searched other than minimum documentation to the extent that such documents are included in the fields searched

Electronic data base consulted during the international search (name of data base and, where practicable, search terms used)
EPO-Internal, WPI Data

C. DOCUMENTS CONSIDERED TO BE RELEVANT		
Category*	Citation of document, with indication, where appropriate, of the relevant passages	Relevant to claim No.
X	US 2003/077107 A1 (KUO YOUTI [US]) 24 April 2003 (2003-04-24)	1,7,8, 10-12, 14-24
Y	paragraphs [0062] - [0067]	13
A	figures 1a-2f	2-6
X	US 2007/283518 A1 (BLANCHARD STEPHEN JOHN [US] ET AL) 13 December 2007 (2007-12-13)	1,6-9, 12,14-18
A	paragraphs [0011] - [0016] figures 2, 7	2-5
X	US 2011/152909 A1 (JIMENEZ EDUARDO [US] ET AL) 23 June 2011 (2011-06-23)	35-38
A	paragraphs [0033], [0035] figures 1-3	25-34,39
	----- -/--	

Further documents are listed in the continuation of Box C.

See patent family annex.

* Special categories of cited documents :

"A" document defining the general state of the art which is not considered to be of particular relevance

"E" earlier application or patent but published on or after the international filing date

"L" document which may throw doubts on priority claim(s) or which is cited to establish the publication date of another citation or other special reason (as specified)

"O" document referring to an oral disclosure, use, exhibition or other means

"P" document published prior to the international filing date but later than the priority date claimed

"T" later document published after the international filing date or priority date and not in conflict with the application but cited to understand the principle or theory underlying the invention

"X" document of particular relevance; the claimed invention cannot be considered novel or cannot be considered to involve an inventive step when the document is taken alone

"Y" document of particular relevance; the claimed invention cannot be considered to involve an inventive step when the document is combined with one or more other such documents, such combination being obvious to a person skilled in the art

"&" document member of the same patent family

Date of the actual completion of the international search 26 October 2015	Date of mailing of the international search report 03/11/2015
Name and mailing address of the ISA/ European Patent Office, P.B. 5818 Patentlaan 2 NL - 2280 HV Rijswijk Tel. (+31-70) 340-2040, Fax: (+31-70) 340-3016	Authorized officer Chabus, Hervé

INTERNATIONAL SEARCH REPORT

International application No
PCT/US2014/072066

C(Continuation). DOCUMENTS CONSIDERED TO BE RELEVANT		
Category*	Citation of document, with indication, where appropriate, of the relevant passages	Relevant to claim No.
X	CN 201 157 105 Y (JINJU CHEN [CN]) 3 December 2008 (2008-12-03)	39
Y	figure	25-38
Y	----- US 2005/000049 A1 (HOHLBEIN DOUGLAS J [US]) 6 January 2005 (2005-01-06) paragraph [0037] figures 1, 7	13
Y	----- JP 2014 087475 A (KAO CORP) 15 May 2014 (2014-05-15) abstract figures 1-4	25-38
A	----- US 2005/210612 A1 (BAERTSCHI A; BELTSCH A; HALLBAIN D J; HOHLBEIN D; HOHLBEIN D J; MINTEL) 29 September 2005 (2005-09-29) paragraphs [0054], [0055] figures 8-13	25-39
A	----- US 6 015 293 A (RIMKUS RONALD J [US]) 18 January 2000 (2000-01-18) column 3, line 66 - column 4, line 67 figures 1, 2	25-39

INTERNATIONAL SEARCH REPORT

International application No.
PCT/US2014/072066

Box No. II Observations where certain claims were found unsearchable (Continuation of item 2 of first sheet)

This international search report has not been established in respect of certain claims under Article 17(2)(a) for the following reasons:

1. Claims Nos.:
because they relate to subject matter not required to be searched by this Authority, namely:

2. Claims Nos.:
because they relate to parts of the international application that do not comply with the prescribed requirements to such an extent that no meaningful international search can be carried out, specifically:

3. Claims Nos.:
because they are dependent claims and are not drafted in accordance with the second and third sentences of Rule 6.4(a).

Box No. III Observations where unity of invention is lacking (Continuation of item 3 of first sheet)

This International Searching Authority found multiple inventions in this international application, as follows:

see additional sheet

1. As all required additional search fees were timely paid by the applicant, this international search report covers all searchable claims.

2. As all searchable claims could be searched without effort justifying an additional fees, this Authority did not invite payment of additional fees.

3. As only some of the required additional search fees were timely paid by the applicant, this international search report covers only those claims for which fees were paid, specifically claims Nos.:

4. No required additional search fees were timely paid by the applicant. Consequently, this international search report is restricted to the invention first mentioned in the claims; it is covered by claims Nos.:

Remark on Protest

- The additional search fees were accompanied by the applicant's protest and, where applicable, the payment of a protest fee.
- The additional search fees were accompanied by the applicant's protest but the applicable protest fee was not paid within the time limit specified in the invitation.
- No protest accompanied the payment of additional search fees.

FURTHER INFORMATION CONTINUED FROM PCT/ISA/ 210

This International Searching Authority found multiple (groups of) inventions in this international application, as follows:

1. claims: 1-24

Oral care implement comprising an elastomeric component including a bumper portion forming a wall portion with a first ramped portion, a second ramped portion and an apex portion in between. Oral care implement comprising a soft tissue cleanser on the rear surface of the head with a plurality of protuberances of different heights.

1.1. claims: 1-9, 11, 12, 14-18

Oral care implement comprising an elastomeric component including a bumper portion forming a wall portion with a first ramped portion, a second ramped portion and an apex portion in between.

1.2. claims: 10, 13, 19-24

Oral care implement comprising an elastomeric component including a bumper portion with a plurality of spaced-apart ridges protruding from its outer surface.

2. claims: 25-39

Oral care implement comprising a soft tissue cleanser on the rear surface of the head with a plurality of protuberances of different heights.

INTERNATIONAL SEARCH REPORT

Information on patent family members

International application No

PCT/US2014/072066

Patent document cited in search report	Publication date	Patent family member(s)	Publication date
US 2003077107	A1	24-04-2003	NONE
US 2007283518	A1	13-12-2007	AU 2007202591 A1 03-01-2008 BR PI0705037 A 22-04-2008 CA 2591209 A1 08-12-2007 EP 1864589 A1 12-12-2007 JP 5269351 B2 21-08-2013 JP 2008006282 A 17-01-2008 US 2007283518 A1 13-12-2007
US 2011152909	A1	23-06-2011	TW 201143673 A 16-12-2011 TW 201436736 A 01-10-2014 US 2011152909 A1 23-06-2011 US 2013307187 A1 21-11-2013
CN 201157105	Y	03-12-2008	NONE
US 2005000049	A1	06-01-2005	AT 407630 T 15-09-2008 EP 1607059 A1 21-12-2005 EP 1985199 A1 29-10-2008 EP 2050355 A1 22-04-2009 ES 2407828 T3 14-06-2013 ES 2466320 T3 10-06-2014 HK 1084851 A1 15-05-2009 HK 1121929 A1 19-09-2013 HK 1130002 A1 05-09-2014 US 2005000049 A1 06-01-2005 US 2007101525 A1 10-05-2007 US 2008052848 A1 06-03-2008 US 2011219556 A1 15-09-2011 US 2013326831 A1 12-12-2013 US 2014325773 A1 06-11-2014
JP 2014087475	A	15-05-2014	NONE
US 2005210612	A1	29-09-2005	AU 2005322213 A1 06-07-2006 BR PI0518656 A2 02-12-2008 CA 2592183 A1 06-07-2006 CA 2826976 A1 06-07-2006 CN 101123897 A 13-02-2008 CN 101822576 A 08-09-2010 CN 102743015 A 24-10-2012 EA 200802180 A1 28-04-2009 EA 201100271 A1 30-06-2011 EA 201391766 A1 30-07-2014 EP 1835825 A2 26-09-2007 KR 20070091667 A 11-09-2007 MY 146515 A 15-08-2012 TW I391105 B 01-04-2013 TW 201328633 A 16-07-2013 US 2005210612 A1 29-09-2005 US 2010229316 A1 16-09-2010 WO 2006071676 A2 06-07-2006
US 6015293	A	18-01-2000	NONE