



(43) International Publication Date
17 December 2015 (17.12.2015)

(51) International Patent Classification:

G01S 17/89 (2006.01) G01S 7/491 (2006.01)
G01S 7/493 (2006.01) G01S 17/46 (2006.01)

(21) International Application Number:

PCT/EP2015/063015

(22) International Filing Date:

11 June 2015 (11.06.2015)

(25) Filing Language:

English

(26) Publication Language:

English

(30) Priority Data:

14171985.6 11 June 2014 (11.06.2014) EP

(71) Applicant: **SOFTKINETIC SENSORS NV** [BE/BE];
Boulevard de la Plaine 11, 1050 Brussels (BE).

(72) Inventor: **VAN DER TEMPEL, Ward**; Piervenshoek 19,
B-3140 Keerbergen (BE).

(74) Agent: **BIRD GOËN & CO**; Gaston Geenslaan 9, 3001
Heverlee (BE).

(81) Designated States (unless otherwise indicated, for every kind of national protection available): AE, AG, AL, AM, AO, AT, AU, AZ, BA, BB, BG, BH, BN, BR, BW, BY, BZ, CA, CH, CL, CN, CO, CR, CU, CZ, DE, DK, DM, DO, DZ, EC, EE, EG, ES, FI, GB, GD, GE, GH, GM, GT, HN, HR, HU, ID, IL, IN, IR, IS, JP, KE, KG, KN, KP, KR, KZ, LA, LC, LK, LR, LS, LU, LY, MA, MD, ME, MG, MK, MN, MW, MX, MY, MZ, NA, NG, NI, NO, NZ, OM, PA, PE, PG, PH, PL, PT, QA, RO, RS, RU, RW, SA, SC, SD, SE, SG, SK, SL, SM, ST, SV, SY, TH, TJ, TM, TN, TR, TT, TZ, UA, UG, US, UZ, VC, VN, ZA, ZM, ZW.

(84) Designated States (unless otherwise indicated, for every kind of regional protection available): ARIPO (BW, GH, GM, KE, LR, LS, MW, MZ, NA, RW, SD, SL, ST, SZ, TZ, UG, ZM, ZW), Eurasian (AM, AZ, BY, KG, KZ, RU, TJ, TM), European (AL, AT, BE, BG, CH, CY, CZ, DE, DK, EE, ES, FI, FR, GB, GR, HR, HU, IE, IS, IT, LT, LU, LV, MC, MK, MT, NL, NO, PL, PT, RO, RS, SE, SI, SK, SM, TR), OAPI (BF, BJ, CF, CG, CI, CM, GA, GN, GQ, GW, KM, ML, MR, NE, SN, TD, TG).

Published:

— with international search report (Art. 21(3))

(54) Title: A TOF CAMERA SYSTEM AND A METHOD FOR MEASURING A DISTANCE WITH THE SYSTEM

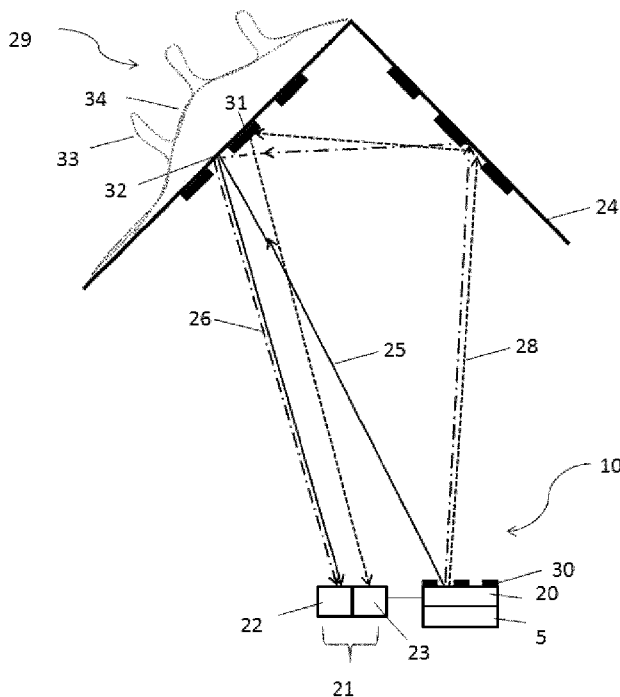

Figure 3

(57) Abstract: The invention relates to a method for measuring a distance between an object of a scene and a Time-Of-Flight camera system, and providing a depth map of the object, the Time-Of-Flight camera system comprising an illumination unit, an imaging sensor having a matrix of pixels and image processing means, the method being characterized by the following steps: modifying in a discrete way the illumination of said illumination unit in order to illuminate elementary areas of the scene with different incident intensities, respectively, for distinguishing the direct incident light beams from the indirect incident light beams; receiving onto the pixels of the matrix of the sensor the beams reflected by said elementary areas and providing the image processing means with corresponding data; processing the said corresponding data for eliminating the influence of the indirect light beams in the depth map of the object.

A TOF CAMERA SYSTEM AND A METHOD FOR MEASURING A DISTANCE WITH THE SYSTEM

Technical field of the invention

5

The invention relates (i) to a method for measuring a distance between an object of a scene and a Time-Of-Flight camera system and (ii) to the Time-Of-Flight camera system associated therewith. In particular, the invention relates to the problem of direct and indirect reflections of light within a scene and to the errors of depth measurements induced by these multiple reflections. It should be understood that by scene is meant all the surfaces surrounding the object onto which a light beam could be directly or indirectly reflected.

10

Background of the invention

15

Time-Of-Flight technology (TOF) is a promising technology for depth perception. The well-known basic operational principle of a standard TOF camera system 3 is illustrated in Figure 1. The TOF camera system 3 captures 3D images of a scene 15 by analysing the time of flight of light from a dedicated illumination unit 18 to an object. TOF camera system 3 includes a camera, for instance a matrix of pixels 1, and data processing means 4. The scene 15 is actively illuminated with a modulated light 16 at a predetermined wavelength using the dedicated illumination unit 18, for instance with some light pulses of at least one predetermined frequency. The modulated light is reflected back from objects within the scene. A lens 2 collects the reflected light 17 and forms an image of the objects onto the imaging sensor 1 of the camera. Depending on the distance of objects from the camera, a delay is experienced between the emission of the modulated light, e.g. the so called light pulses, and the reception at the camera of those reflected light pulses. Distance between reflecting objects and the camera may be determined as function of the time delay observed and the speed of light constant value.

20

25

One of the drawbacks of this technology is illustrated by Figure 2 and is related to the so-called multipath phenomenon. A standard TOF camera system 9 is represented, comprising an illumination unit 8 for illuminating a scene 24 in multiple directions, a TOF

30

sensor 6 for detecting the reflections of the emitted light and processing means 7 for processing the data acquired by the TOF sensor 6.

5 The pixels of TOF sensor 6, not represented, measure direct path 25 from the illumination unit 8 to the scene 24 and from the scene 24 back to the pixels. But secondary reflections 26 or higher order reflections can be captured as well on the same pixel and distort the perceived delay for the first direct reflection 25. The light captured by the sensor 6 can originate from both the direct path 25 and the secondary reflection 26, the depth map 27, representing the depth associated to each point of the scene, measured is thereby erroneous.

10 In prior art, several methods have been implemented to recover the direct component of impinging light. For instance, multiple frequency approaches have been performed, by acquiring a set of depth measurements with different modulation frequencies, but the resolution obtained remains low.

15 Another approach uses a set of different spatial patterns which are generated by, for example, a Digital Light Processing (DLP) projector. By creating dark and bright patches in the scene, the direct and indirect components can be separated, as the depth acquired from the black part of the pattern is created by only indirect signal originating from multipath. The different patterns are chosen in such a way that each part of the scene is captured in a black situation. Edge-effects are countered by defining the patterns with sufficient overlaps. However, the creation of these different patterns is
20 expensive.

A solution remains to be proposed in order to retrieve only the direct component of the reflected light in the most cost-effective way, in order to perform more accurate
25 measurements of the distances between objects of a scene and the TOF camera system.

Summary of the invention

30 The present invention relates to a method for measuring a distance between an object of a scene and a Time-Of-Flight camera system, and providing a depth map of

the object, the Time-Of-Flight camera system comprising an illumination unit, an imaging sensor having a matrix of pixels and image processing means, the method being characterized by the following steps:

- 5 - modifying in a discrete way the illumination of said illumination unit in order to illuminate elementary areas of the scene with different incident intensities, respectively, for distinguishing the direct incident light beams from the indirect incident light beams;
- receiving onto the pixels of the matrix of the sensor the beams reflected by said elementary areas and providing the image processing means with corresponding data;
- 10 - processing the said corresponding data for eliminating the influence of the indirect light beams in the depth map of the object.

Advantageously, when processing the data, the method could comprise a step of identifying, for instance on an intermediary depth maps but not only, peaks associated to elementary areas on which only indirect incident light beams can impinge. By identifying such peaks, the data could be processed for eliminating the influence of
15 indirect light beams and obtaining a final accurate depth map of the scene.

The present invention also relates to a Time-Of-Flight (TOF) camera system for measuring a distance between an object of a scene and the TOF camera system, and providing a depth map of the object, the TOF camera system comprising:

- an illumination unit for illuminating the scene with a modulated light;
- 20 - an imaging sensor having a matrix of pixels for receiving onto the pixels of the matrix of the sensor the beams reflected by the scene;
- image processing means for receiving from the imaging sensor, data corresponding to the reflected beams and for processing the said corresponding data;

characterized in that it further comprises:

- 25 - patterning means for modifying in a discrete way the illumination of said illumination unit in order to illuminate elementary areas of the scene with different incident intensities, respectively, for distinguishing the direct incident light beams from the

indirect incident light beams and for eliminating the influence of the indirect light beams in the depth map of the object in processing the said corresponding data.

Advantageously, the modification of the illumination is performed by masking the illumination unit in a discrete way. The patterning means could be for instance a mask
5 avoiding direct incident light beams to impinge on some elementary areas of the scene.

More advantageously, the patterning means could comprise a series of identical pattern groups for enabling an easier processing of the data.

Other advantages and novel features of the invention will become more apparent
10 from the following detailed description when taken in conjunction with the accompanying drawings.

Brief description of the drawings

15 The present invention shall be better understood in light of the following description and the accompanying drawings.

Figure 1 illustrates the basic operational principle of a TOF camera system;

Figure 2 illustrates the multipath phenomenon;

20 Figure 3 illustrates a TOF camera system according to an embodiment of the invention;

Figure 4 illustrates an example of patterning means;

Figure 5 illustrates an intermediary depth map of a scene and the associated pixels of the TOF camera system;

25 Figure 6 illustrates a scene and a light pattern projected on the scene comprising two different spatial zones.

Advantages and novel features of the invention will become more apparent from the following detailed description when taken in conjunction with the accompanying drawing.

Description of the invention

Figure 3 illustrates a TOF camera system 10 according to an embodiment of the invention. The Time-Of-Flight camera system 10 comprises an illumination unit 20 for illuminating a scene 24 with a modulated light. The light emitted by this illumination unit 20 is arranged for being suitable for measuring distances using the Time-Of-Flight technology. For instance, the illumination unit 20 may be arranged for emitting light pulses with an appropriate pulse width. Indeed, when using pulses, the pulse width of each light pulse determines the camera range. For instance, for a pulse width of 50 ns, the range is limited to 7.5 m. As a consequence, the illumination of the scene becomes critical to the operation of a TOF camera system, and the high speed driving frequency requirements for illumination units necessitate the use of specialised light sources such as light emitting diodes (LEDs) or lasers to generate such short light pulses. The illumination unit is arranged for emitting multi-directional light, as represented by the plurality of emitted light rays 25, 26 and 28 represented in Figure 3.

The TOF camera system further comprises an imaging sensor 21 typically comprising a matrix array of pixels, for receiving and detecting the reflected beams and forming an image of the scene 24. For clarity and illustration purposes, only two pixels 22 and 23 have been represented on Figure 3, but the invention should not be limited to a matrix of two pixels. By pixel, it should be understood the picture element sensitive to light electromagnetic radiations and its associated electronic circuitry. The output of the pixels can be used to determine the time of flight of light from the illumination unit 20 to an object in the scene 24 and reflected back from the object to the imaging TOF sensor 21.

The TOF camera system 10 further comprises patterning means 30 for creating a light pattern on the scene 24. The light pattern may be a native laser speckle pattern obtained directly from laser light interferences, or be obtained from patterning means which may be placed in front of the illumination unit 20, or a combination of both the laser speckle and a patterning means 30. When using the patterning means 30, the light emitted by the illumination unit 20 passes through these patterning means, causing the light to be modified and to form a light pattern on the scene, with delimited elementary areas 31, 32 of different intensities. Prior to impinging the scene 24, the light emitted by

the illumination unit 20 may be blocked or its intensity may be reduced on given areas of the patterning means 30 and not blocked on other areas, resulting in the creation of areas with low light intensity 31 and high light intensity 32, respectively, on the scene. For illustration purposes, these areas have been represented by thick lines 31 and 32, 5 but it should be understood that the light pattern created on the scene is not a solid or a physical pattern attached on the scene 24, but the result of light effects originated from the patterning means 30 placed in front of the illumination unit 20. The light pattern is projected on the scene by the illumination unit 20. The patterning means 30 can be filtering means, a mask, a grid or any means enabling to modify in a discrete way the 10 illumination. Ideally, the patterning means should provide a spatially periodic light pattern 31, 32, 45, 46 on the scene, for retrieving easily the areas 31 where only secondary reflections are measured. The patterning means 30 could also comprise a series of identical pattern groups 50 as represented in Figure 4 or a series of different pattern groups that can be sequentially used in time in synchrony with a multiple of the 15 TOF camera frame rate.

It is important to note that the invention does not require a pattern with a contrast of 100%, and that there is no need to align patterning means to the image sensor.

20 The TOF camera system 10 further comprises processing means 5 for determining the time of flight of light emitted by the illumination 20, and thereby, the distance between an object of the scene 24 and the imaging sensor 21. The processing means 30 are arranged for receiving data from the pixels of the imaging sensor 21 and for processing them for eliminating the influence of the indirect light beams in the depth 25 map of the object. The method for determining this distance, and a final and accurate depth map of the object, will be described in the following paragraphs. The time of flight can be calculated in a separate processing unit which may be coupled to the TOF sensor 21 or may directly be integrated into the TOF sensor itself. In Figure 3, the processing means 5 have been represented coupled to the illumination unit 20, but the 30 invention is not limited thereto.

A method for measuring a distance between an object of a scene and the Time-Of-Flight camera system and providing a depth map of the object, the Time-Of-Flight camera system 10 comprising an illumination unit 20, an imaging sensor 21 having a

matrix of pixels 22, 23 and image processing means 30, will be now described, by referring to Figure 3, Figure 4, Figure 5 and Figure 6.

The method comprises the step of modifying in a discrete way the illumination of the illumination unit 20 in order to illuminate elementary areas 31, 32 of the scene with different incident intensities, respectively, for distinguishing the direct incident light beam 25 from the indirect incident light beam 26, 28. This modification can be performed for instance by creating a light pattern on a scene, the light pattern comprising delimited elementary areas with high and low light intensity. This light pattern can be created by placing the patterning means 30 in front of the illumination unit 20, and thus, projecting a light pattern on the scene.

The pixels of the sensor 21 receive the beams reflected by these elementary areas 31, 32 and provide the image processing means 30 with corresponding data.

These data are then processed for eliminating the influence of the indirect light beams and obtaining an accurate depth map of the object.

The light pattern projected on the scene can be retrieved on the intermediary depth map 29. This is illustrated by Figure 3 and Figure 5. By comparing the depth maps 27 of Figure 2 and 29 of Figure 3, without and with the use of the patterning means, respectively, one can notice the apparition of peaks 33. These peaks 33 correspond to areas 31 of the scene 24 where only secondary reflections are measured. Indeed, in these areas, without secondary reflection, pixels of the imaging sensor 21 should not measured light, or with a small intensity because, by definition, these areas 31 are associated to areas of the patterning means 30 where the light is blocked or where the light intensity is reduced. The light measured on pixel 23 is more dominated by the secondary reflection 28, whereas the light measured on pixel 22 corresponds to both direct and indirect components 25, 26. The fact of identifying, for instance on an intermediary depth map 29, elementary areas 31 on which no direct incident light beam can impinge can be used for eliminating the influence of indirect light beams and obtaining a final and accurate depth map of the object. The complex data obtained by the time of flight measurement of light dominated by the indirect components in pixel 23 can for example be subtracted from the complex data obtained by both direct and indirect components in pixel 22 to form a new complex data NC. If the indirect

component contributions to the complex data are equal in pixel 22 and 23, the resulting complex data NC only contains information from the direct component. Even if pixel 23 still received a small direct component due to the limited contrast of the patterning means 30, the resulting complex data NC will have a smaller amplitude but will have the correct phase representing the time of flight of the direct component.

Figure 5 illustrates an intermediary depth map of an object of the scene 29 and the associated pixels of the TOF camera system. Pixels 40 measure only indirect components and are associated to higher depth and peaks 33, whereas pixels 41 measure both direct and indirect components, and are associated to areas 34 of the depth map 29. The identification of the pixels corresponding to the areas 31 can also be done using a signal intensity map, where these pixels will have lower intensity due to the missing direct components. Confidence maps or noise maps can also be used to identify the pixels associated with the areas 31.

By referring to Figure 3, for determining only the direct component 25 of the reflected light, for pixel 22 for instance, the complex value measured by the pixel 22 can be subtracted from the complex value measured by the pixel 23 to form a new complex value NC.

In an actual system there will be more than 2 pixels, and an indirect component function can be constructed by the samples taken on the areas 31. This indirect component function can then be interpolated for all pixels having both direct and indirect components and subtracted from these pixels, leaving only direct components.

When the scene is quite simple, and the reflectance of the scene ideal, the value associated to indirect components is a continuous function which can be easily sampled by all areas 31, because the indirect components originate from a Lambertian reflectance of the scene 24.

When the scene is more complex, the calculation may be performed differently. The scene 40 of Figure 6 comprises for instance a first wall 43 with a door and a second wall 41, on which a cupboard 42, with a given depth, is mounted. In this example, indirect reflections originating from the reflection of the cupboard 42 or from the wall 43 do not lead to similar measurements. For determining the direct component of the

reflected light, different spatial zones 45, 46 of light pattern on the scene 40 can be determined. For illustration purposes, different shapes have been used in Figure 6, but it should be understood that both light sub-patterns 45 and 46 originate from the same patterning means 30 placed in front of the illumination unit 20 of the TOF camera system 10. The scene is now first segmented using the depth data available or any additional data useful for segmenting the scene. For each segment of the scene, again an continuous function can be associated with the indirect components, which can be sampled by the areas 31 belonging to each segment respectively. This indirection component function linked to each segment can then be used to compensate for the unwanted indirect components present in the pixels with both direct and indirect components.

Claims

1. A method for measuring a distance between an object of a scene (24, 40) and a Time-Of-Flight camera system (10), and providing a depth map of the object, the Time-Of-Flight camera system (10) comprising an illumination unit (20), an imaging sensor (21) having a matrix of pixels (22, 23) and image processing means (30), the method being characterized by the following steps:
 - modifying in a discrete way the illumination of said illumination unit (20) in order to illuminate elementary areas (31, 32) of the scene with different incident intensities, respectively, for distinguishing the direct incident light beams (25) from the indirect incident light beams (26, 28);
 - receiving onto the pixels of the matrix of the sensor (21) the beams reflected by said elementary areas (31, 32) and providing the image processing means (30) with corresponding data;
 - processing the said corresponding data for eliminating the influence of the indirect light beams in the depth map of the object by subtracting the complex data obtained by the time of flight measurement of light dominated by the indirect components from the complex data obtained by both direct and indirect components to form a new complex data.
2. The method of claim 1, wherein the step of modifying the illumination is a step of masking the illumination unit (20) in a discrete way for creating elementary areas (31) on the scene on which no direct incident light beam can impinge.
3. The method of claim 1 or 2, wherein the step of processing the said corresponding data comprises the step of identifying elementary areas (31) on which only indirect incident light beams can impinge.
4. The method according to any one of the previous claims, further comprising the step of determining two different spatial zones (45, 46) of elementary areas on the scene (24, 40), associated with different sets of pixels of said matrix of pixels (22, 23), respectively.

5. A Time-Of-Flight (TOF) camera system (10) for measuring a distance between an object of a scene (24, 40) and the TOF camera system (10), and providing a depth map of the object, the TOF camera system comprising:

- 5 - an illumination unit (20) for illuminating the scene (24) with a modulated light;
- an imaging sensor (21) having a matrix of pixels (22, 23) for receiving onto the pixels of the matrix of the sensor (21) the beams reflected by the scene (24, 40);
- image processing means (5) for receiving from the imaging sensor (21), data corresponding to the reflected beams and for processing the said corresponding data;
- 10

characterized in that

the TOF camera system further comprises patterning means (30) for modifying in a discrete way the illumination of said illumination unit (20) in order to illuminate elementary areas (31, 32) of the scene with different incident intensities, respectively, for distinguishing the direct incident light beams (25) from the indirect incident light beams (26, 28) and

15

in that the image processing means (5) are configured for eliminating the influence of the indirect light beams in the depth map of the object in processing the said corresponding data by subtracting the complex data obtained by the time of flight measurement of light dominated by the indirect components from the complex data obtained by both direct and indirect components to form a new complex data.

20

6. The TOF camera system (10) of claim 5, wherein the patterning means (30) are placed in front of the illumination unit (20) for projecting a light pattern (31, 32, 45, 46) on the scene.

25 7. The TOF camera system (10) of claim 5 or 6, wherein the patterning means (30) comprises a series of identical pattern groups (50).

8. The TOF camera system (10) of any one of claims 5 to 6, wherein the patterning means (30) includes a mask avoiding direct incident beams to impinge on some elementary areas (31) of the scene (24,40).

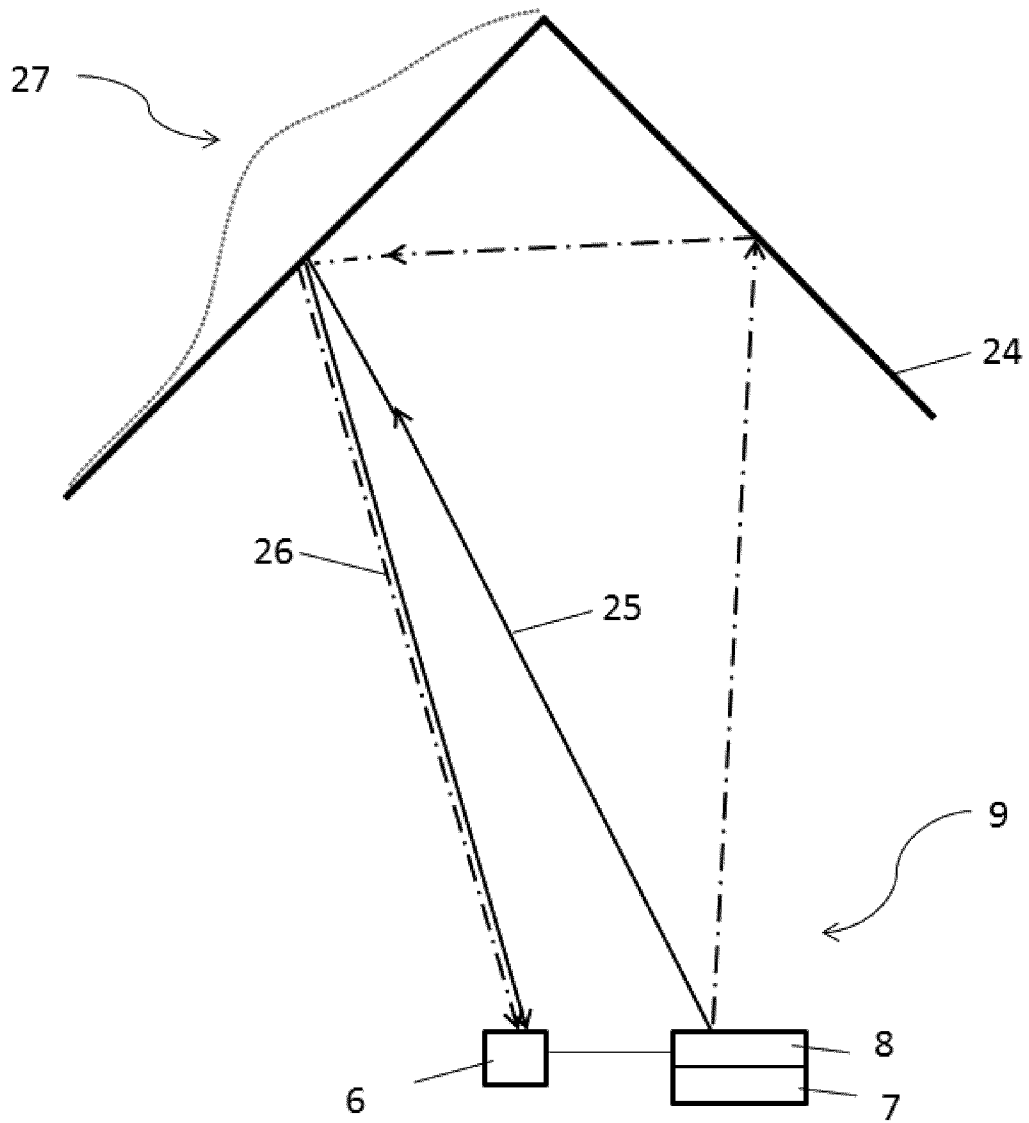

Figure 2

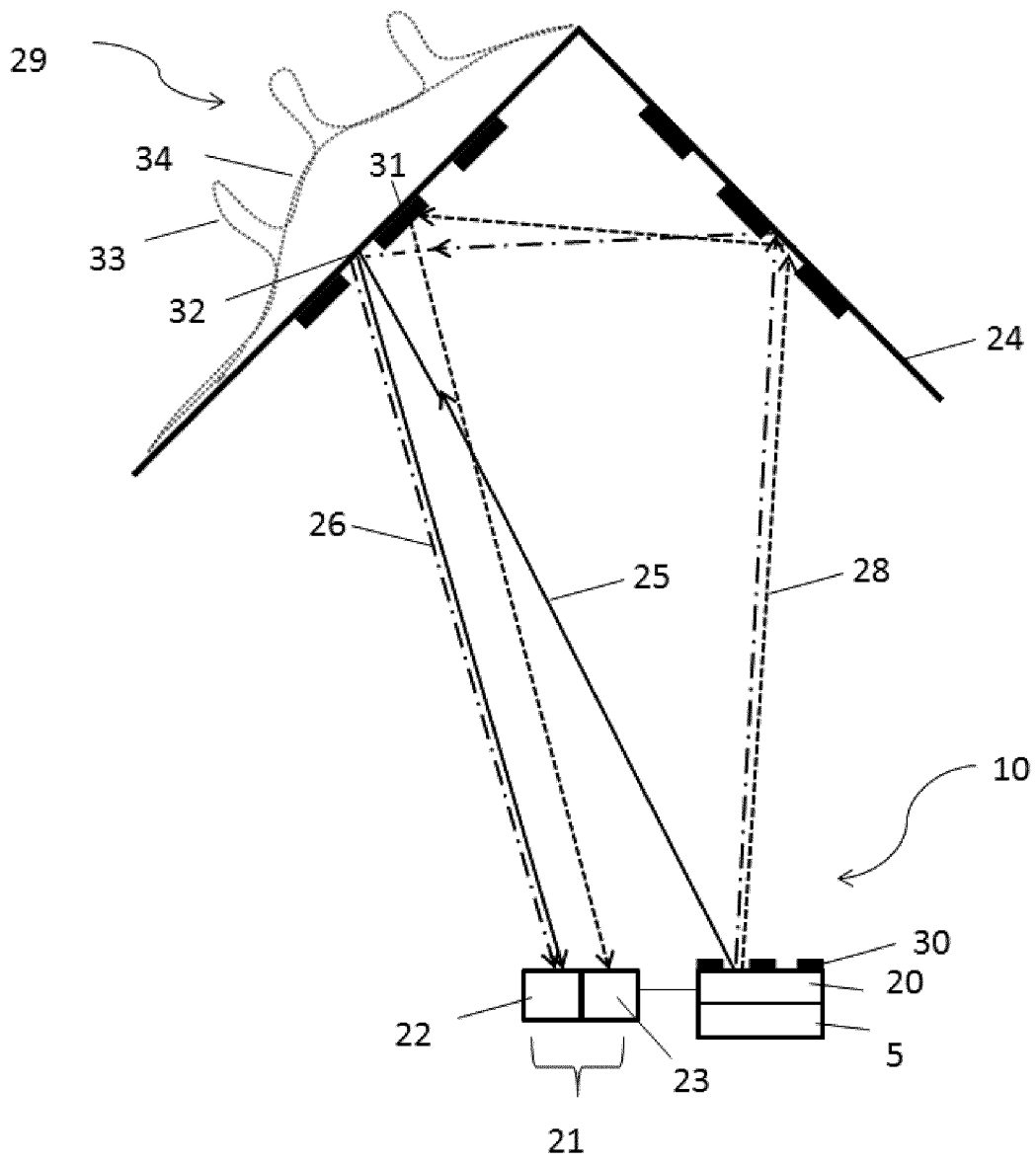

Figure 3

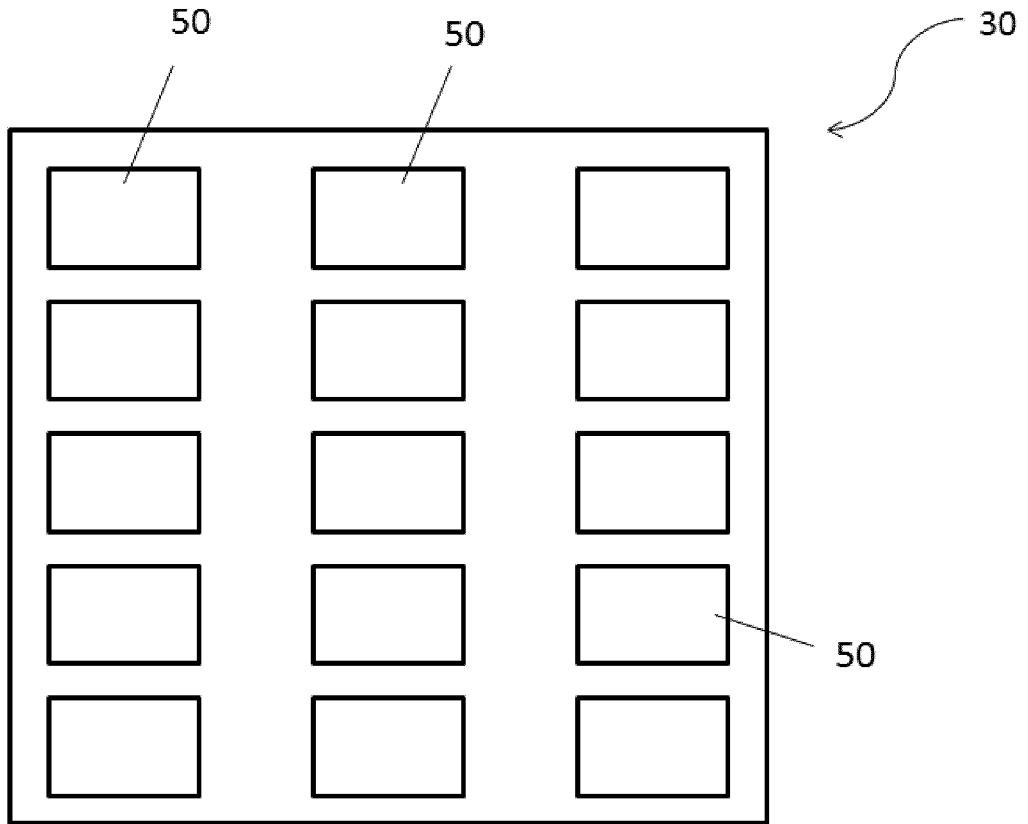

Figure 4

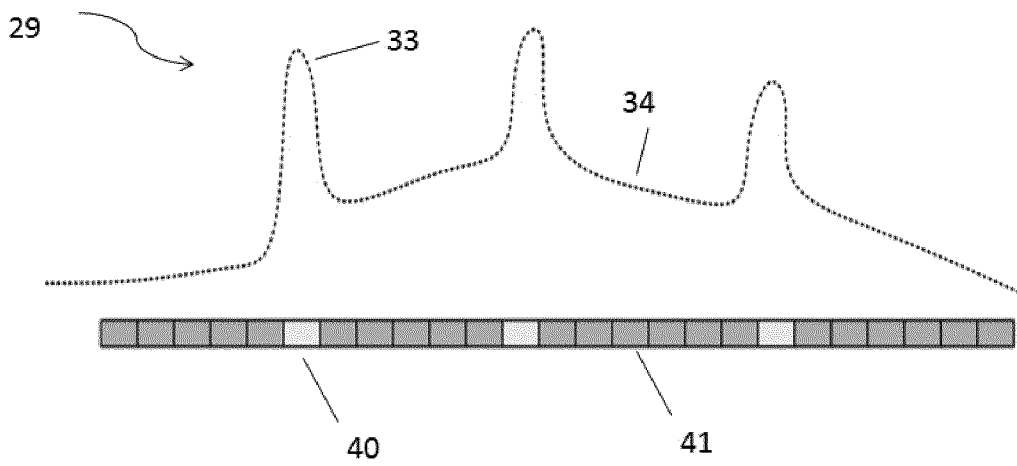

Figure 5

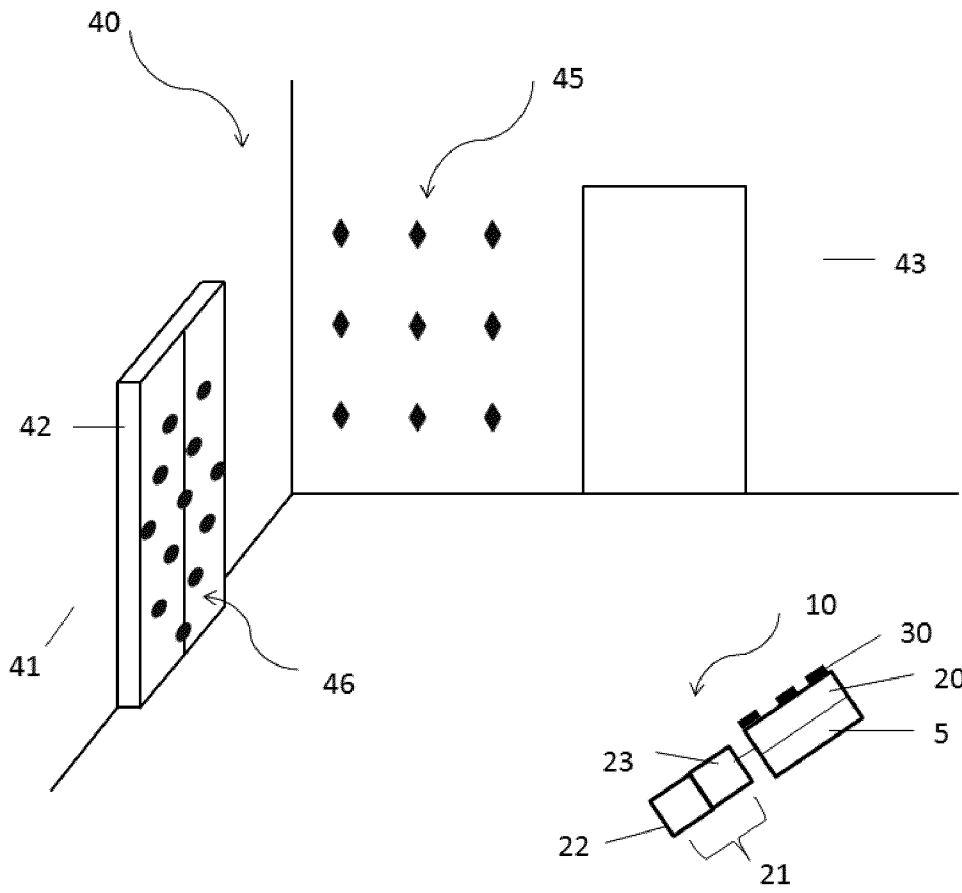

Figure 6

INTERNATIONAL SEARCH REPORT

International application No
PCT/EP2015/063015

A. CLASSIFICATION OF SUBJECT MATTER
 INV. G01S17/89 G01S7/493 G01S7/491
 ADD. G01S17/46

According to International Patent Classification (IPC) or to both national classification and IPC

B. FIELDS SEARCHED

Minimum documentation searched (classification system followed by classification symbols)
 G01S

Documentation searched other than minimum documentation to the extent that such documents are included in the fields searched

Electronic data base consulted during the international search (name of data base and, where practicable, search terms used)
 EPO-Internal, WPI Data

C. DOCUMENTS CONSIDERED TO BE RELEVANT

Category*	Citation of document, with indication, where appropriate, of the relevant passages	Relevant to claim No.
A	FALIE D ET AL: "Distance errors correction for the Time of Flight (ToF) cameras", IMAGING SYSTEMS AND TECHNIQUES, 2008. IST 2008. IEEE INTERNATIONAL WORKSHOP ON, IEEE, PISCATAWAY, NJ, USA, 10 September 2008 (2008-09-10), pages 123-126, XP031354709, ISBN: 978-1-4244-2496-2 the whole document ----- -/--	1-8

Further documents are listed in the continuation of Box C.

See patent family annex.

* Special categories of cited documents :

"A" document defining the general state of the art which is not considered to be of particular relevance

"E" earlier application or patent but published on or after the international filing date

"L" document which may throw doubts on priority claim(s) or which is cited to establish the publication date of another citation or other special reason (as specified)

"O" document referring to an oral disclosure, use, exhibition or other means

"P" document published prior to the international filing date but later than the priority date claimed

"T" later document published after the international filing date or priority date and not in conflict with the application but cited to understand the principle or theory underlying the invention

"X" document of particular relevance; the claimed invention cannot be considered novel or cannot be considered to involve an inventive step when the document is taken alone

"Y" document of particular relevance; the claimed invention cannot be considered to involve an inventive step when the document is combined with one or more other such documents, such combination being obvious to a person skilled in the art

"&" document member of the same patent family

Date of the actual completion of the international search 20 July 2015	Date of mailing of the international search report 27/07/2015
---	--

Name and mailing address of the ISA/ European Patent Office, P.B. 5818 Patentlaan 2 NL - 2280 HV Rijswijk Tel. (+31-70) 340-2040, Fax: (+31-70) 340-3016	Authorized officer Kern, Olivier
--	---

INTERNATIONAL SEARCH REPORT

International application No
PCT/EP2015/063015

C(Continuation). DOCUMENTS CONSIDERED TO BE RELEVANT		
Category*	Citation of document, with indication, where appropriate, of the relevant passages	Relevant to claim No.
X	FALIE D ET AL: "Further investigations on ToF cameras distance errors and their corrections", CIRCUITS AND SYSTEMS FOR COMMUNICATIONS, 2008. ECCSC 2008. 4TH EUROPEAN CONFERENCE ON, IEEE, PISCATAWAY, NJ, USA, 10 July 2008 (2008-07-10), pages 197-200, XP031315023, ISBN: 978-1-4244-2419-1 pages 198-199; figures 1,3-6	1-8
A	----- US 2013/148102 A1 (OGGIER THIERRY [CH]) 13 June 2013 (2013-06-13) paragraphs [0004], [0017] - [0020], [0037]; claim 1; figures 1,,3-7	1-8
A	----- US 2014/055771 A1 (OGGIER THIERRY [CH]) 27 February 2014 (2014-02-27) paragraphs [0009], [0046]; figures 1, 3, 4,	1-8
A	----- US 2014/049609 A1 (WILSON ANDREW [US] ET AL) 20 February 2014 (2014-02-20) paragraphs [0001], [0002], [0007], [0008]; claims 2,5,7; figures 1-5, 8	1-8

INTERNATIONAL SEARCH REPORT

Information on patent family members

International application No

PCT/EP2015/063015

Patent document cited in search report	Publication date	Patent family member(s)	Publication date
US 2013148102	A1	13-06-2013	NONE

US 2014055771	A1	27-02-2014	EP 2815251 A1 24-12-2014
			JP 2015513825 A 14-05-2015
			US 2014055771 A1 27-02-2014
			WO 2013121267 A1 22-08-2013

US 2014049609	A1	20-02-2014	US 2014049609 A1 20-02-2014
			WO 2014028276 A1 20-02-2014
