



(51) International Patent Classification:

*H02M* 7/66 (2006.01)      *H02P* 13/06 (2006.01)  
*H01F* 29/02 (2006.01)      *C25B* 1/04 (2021.01)  
*H02M* 3/00 (2006.01)      *C25B* 5/00 (2006.01)

(21) International Application Number:

PCT/US2023/035152

(22) International Filing Date:

13 October 2023 (13.10.2023)

(25) Filing Language:

English

(26) Publication Language:

English

(30) Priority Data:

63/416,290      14 October 2022 (14.10.2022)      US

(71) Applicant: **OHIUM INTERNATIONAL, INC.**  
[US/US]; 885 Tahoe Blvd., Suite B1, Incline Village, NV  
89451 (US).

(72) Inventors: **BALLANTINE, Arne**; 885 Tahoe Blvd., Suite  
B1, Incline Village, NV 89451 (US). **ADAPA, Anil, Ku-  
mar**; 885 Tahoe Blvd., Suite B1, Incline Village, NV 89451  
(US). **KARUPPAIAH, Chockkalingam**; 885 Tahoe Blvd.,  
Suite B1, Incline Village, NV 89451 (US).

(74) Agent: **RONNEBAUM, Blake, Andrew** et al.; PO Box  
140310, Kansas City, MO 64114-0310 (US).

(81) Designated States (*unless otherwise indicated, for every  
kind of national protection available*): AE, AG, AL, AM,  
AO, AT, AU, AZ, BA, BB, BG, BH, BN, BR, BW, BY, BZ,  
CA, CH, CL, CN, CO, CR, CU, CV, CZ, DE, DJ, DK, DM,  
DO, DZ, EC, EE, EG, ES, FI, GB, GD, GE, GH, GM, GT,  
HN, HR, HU, ID, IL, IN, IQ, IR, IS, IT, JM, JO, JP, KE, KG,

(54) Title: SYSTEMS AND CIRCUITS FOR CONNECTING COMPONENTS OF A HYDROGEN PLANT TO A POWER SOURCE

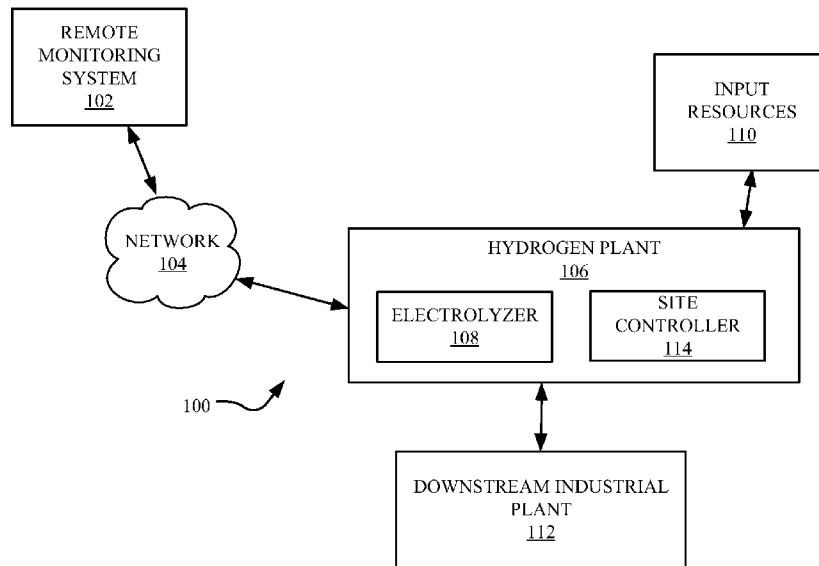

FIG. 1

(57) Abstract: The present disclosure relates to circuits for connecting components of a hydrogen plant to a power grid to power the components in an efficient manner. In one implementation, power-side alternate current (AC) to direct current (DC) converters may be connected to a source power grid without the need for an isolation transformer by providing separate buses between the power-side AC-DC converters and load-side DC-DC converters instead of a shared DC bus between the converters. Other implementations for connecting components of a hydrogen plant to a power grid may include an adjustable transformer, such as a tappable transformer or an autotransformer, to connect any number of auxiliary loads of the plant to the power grid. The adjustable transformer may provide for various types of auxiliary load devices to connect to the power provided by the transformer at the same time, including both three-phase devices and one-phase devices.



KH, KN, KP, KR, KW, KZ, LA, LC, LK, LR, LS, LU, LY,  
MA, MD, MG, MK, MN, MU, MW, MX, MY, MZ, NA,  
NG, NI, NO, NZ, OM, PA, PE, PG, PH, PL, PT, QA, RO,  
RS, RU, RW, SA, SC, SD, SE, SG, SK, SL, ST, SV, SY, TH,  
TJ, TM, TN, TR, TT, TZ, UA, UG, US, UZ, VC, VN, WS,  
ZA, ZM, ZW.

**(84) Designated States** (*unless otherwise indicated, for every kind of regional protection available*): ARIPO (BW, CV, GH, GM, KE, LR, LS, MW, MZ, NA, RW, SC, SD, SL, ST, SZ, TZ, UG, ZM, ZW), Eurasian (AM, AZ, BY, KG, KZ, RU, TJ, TM), European (AL, AT, BE, BG, CH, CY, CZ, DE, DK, EE, ES, FI, FR, GB, GR, HR, HU, IE, IS, IT, LT, LU, LV, MC, ME, MK, MT, NL, NO, PL, PT, RO, RS, SE, SI, SK, SM, TR), OAPI (BF, BJ, CF, CG, CI, CM, GA, GN, GQ, GW, KM, ML, MR, NE, SN, TD, TG).

**Published:**

- with international search report (*Art. 21(3)*)
- with amended claims (*Art. 19(1)*)

**(88) Date of publication of the international search report:**

16 May 2024 (16.05.2024)

**Date of publication of the amended claims:**

27 June 2024 (27.06.2024)

## AMENDED CLAIMS

received by the International Bureau on 7 May 2024 (07.05.2024)

What is claimed is:

1. A hydrogen-generating plant comprising:  
a plurality of non-isolated, bi-directional alternate current (AC) to direct current (DC) converters each comprising an input in electrical communication with a power source and an output, each of the plurality of AC-DC converters converting an AC power signal from the power source to a DC power signal;  
and  
a plurality of isolated, uni-directional DC-DC converters each comprising an input in electrical connection to at least one of the plurality of AC-DC converters and an output in electrical communication with a load;  
wherein a first subset of the plurality of DC-DC converters is connected in parallel to an output of a first AC-DC converter and a second, distinct subset of the plurality of DC-DC converters is connected in parallel to an output of a second AC-DC converter to electrically isolate the first AC-DC converter from the second AC-DC converter.
2. The hydrogen-generating plant of claim 1 wherein the load is an electro-chemical load.
3. The hydrogen-generating plant of claim 1 wherein the load comprises at least one electrolyzer.
4. The hydrogen-generating plant of claim 1 wherein the power source is one of a grid power source or a renewable power source.
5. The hydrogen-generating plant of claim 1 further comprising:  
a transformer comprising a primary winding in electrical communication with the power source and a secondary winding in electrical communication with one or more auxiliary loads.

6. The hydrogen-generating plant of claim 5 wherein the transformer is an adjustable transformer comprising one or more taps on the primary winding or the secondary winding to adjust a windings ratio of the transformer.
7. The hydrogen-generating plant of claim 5 wherein the transformer is a solid-state transformer.
8. The hydrogen-generating plant of claim 5 wherein the one or more auxiliary loads comprise three-phase loads and single-phase loads.
9. The hydrogen-generating plant of claim 8 wherein the transformer is configured to provide power to the three-phase loads and single-phase loads.
10. The hydrogen-generating plant of claim 5 further comprising:  
an uninterruptible power supply in electrical communication with the one or more auxiliary loads.
11. A method for operating a hydrogen generator, the method comprising:  
electrically connecting a plurality of non-isolated, bi-directional alternate current (AC) to direct current (DC) converters to a power source;  
electrically connecting a first subset of a plurality of isolated, uni-directional DC-DC converters between an output of a first AC-DC converter of the plurality of AC-DC converters and a load circuit, the first subset of the plurality of DC-DC converters in parallel to each other; and  
electrically connecting a second subset of the plurality of DC-DC converters between an output of a second AC-DC converter of the plurality of AC-DC converters and the load circuit, the second subset of the plurality of DC-DC converters in parallel to each other,  
wherein the first AC-DC converter is electrically isolated from the second AC-DC converter.
12. The method of claim 11 wherein the load comprises at least one electrolyzer.
13. The method of claim 11 further comprising:

electrically connecting one or more auxiliary loads to the power source via a transformer.

14. The method of claim 13 wherein the one or more auxiliary loads comprise three-phase loads and single-phase load.
15. The method of claim 13 wherein the transformer is configured to provide power to the three-phase loads and single-phase loads.
16. The method of claim 13 further comprising:  
electrically connecting a bypass switch between the one or more auxiliary loads and an uninterruptible power supply (UPS), the bypass switch to switch power to the one or more auxiliary loads from the power source to the UPS in response to a loss of power by the power source.