

E. E. ELLIOTT.  
SACK HOLDER.

APPLICATION FILED JULY 31, 1902.

NO MODEL.

2 SHEETS—SHEET 1.

Fig 1.

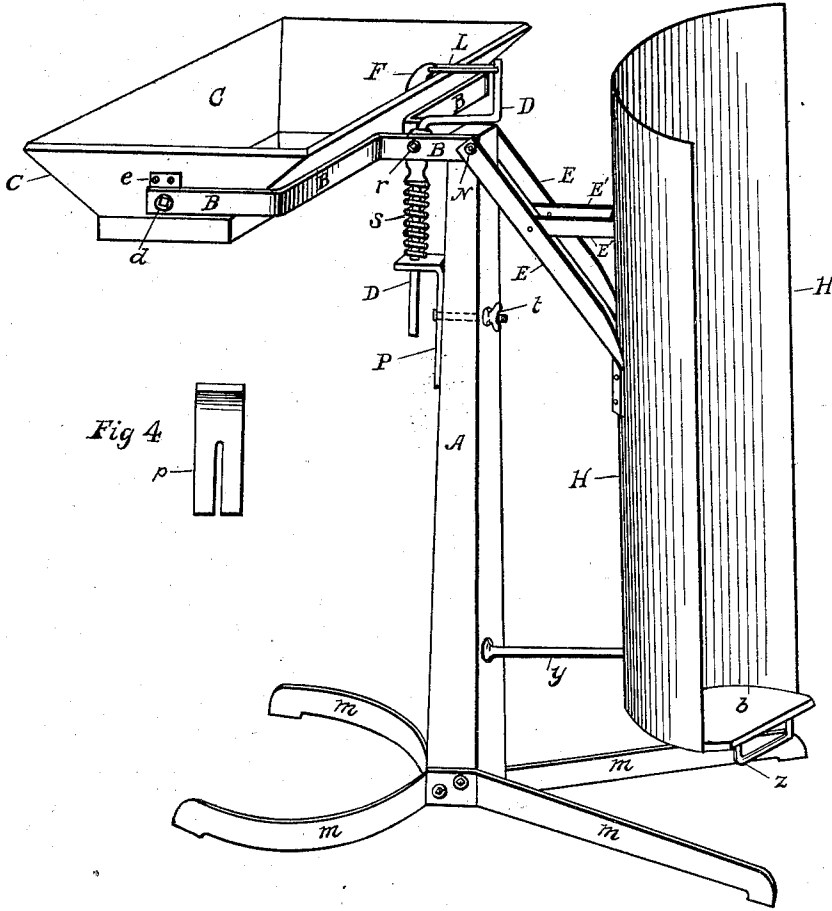

Fig 4

WITNESSES:

*A. J. Kies*

*Ordo L. Olive*

INVENTOR

*Edward E. Elliott*

BY

*Joseph L. Custer*  
ATTORNEY

E. E. ELLIOTT.  
SACK HOLDER.

APPLICATION FILED JULY 31, 1902.

NO MODEL.

2 SHEETS—SHEET 2.

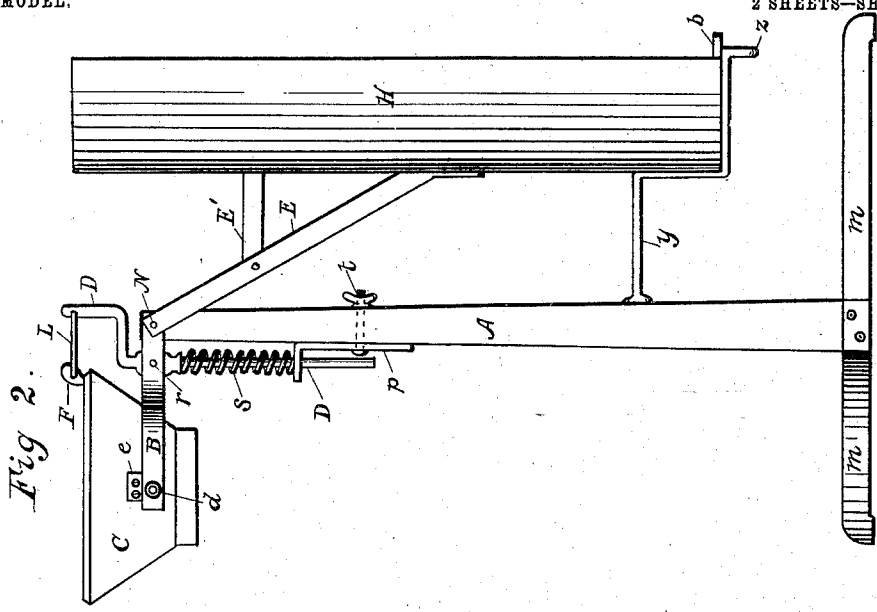

Fig 2.

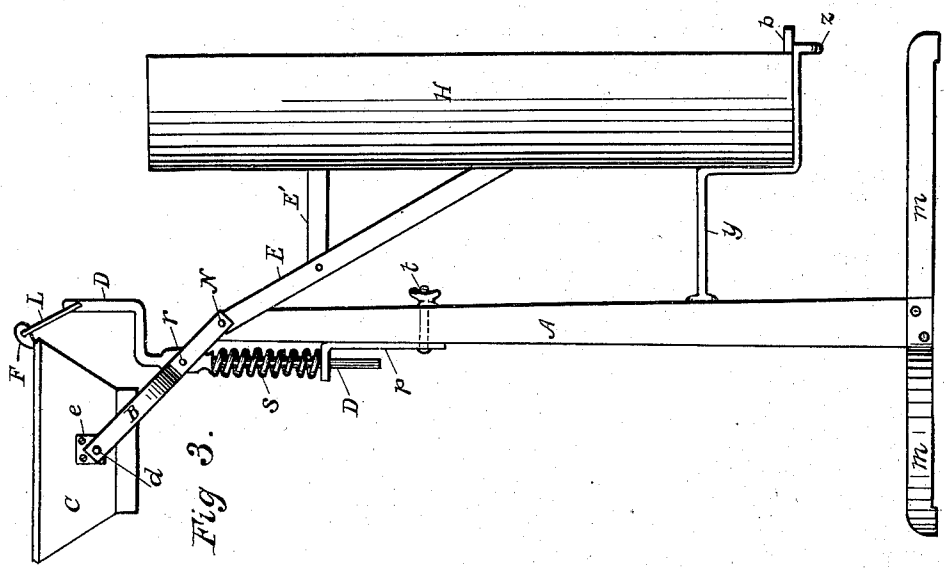

Fig 3.

WITNESSES:

-----  
*A. J. Files,*  
 -----  
*Oslo L. Colvine,*  
 -----

INVENTOR

-----  
*Edward E. Elliott,*  
-----

BY

-----  
*Joseph L. Custer,*  
 -----  
 ATTORNEY

# UNITED STATES PATENT OFFICE.

EDWARD E. ELLIOTT, OF RADLEY, INDIANA.

## SACK-HOLDER.

SPECIFICATION forming part of Letters Patent No. 731,442, dated June 23, 1903.

Application filed July 31, 1902. Serial No. 117,796. (No model.)

*To all whom it may concern:*

Be it known that I, EDWARD E. ELLIOTT, a citizen of the United States, residing at Radley, in the county of Grant and State of Indiana, have invented a new and useful Sack-Holder, of which the following is a specification.

My invention relates to improvements in sack-holders for holding and adjusting sacks in an upright position and facilitating the emptying and filling of sacks.

The object of the invention is to provide a portable sack filler and emptier simple in construction, durable, easy of operation, adapted to extensive use, and calculated to reduce the labor and expense of handling, emptying, and filling sacks.

The accompanying drawings illustrate the mechanism by which these objects are attained and by which the invention may be carried out and utilized, but which it is intended may be modified and changed in minor details without departure from the essential elements of the invention.

In the drawings similar letters refer to similar parts throughout the several views.

Figure 1 is a view in perspective of the entire apparatus, comprising the base and standard, the bag-holder, and attached bag-emptier and connecting parts. Fig. 2 is a side elevation of the apparatus, showing the same parts as those illustrated in Fig. 1. Fig. 3 is the same as Fig. 2, but showing the hopper operative in elevated position. Fig. 4 is a detailed view of the adjustable bracket with slot therein operating on the side of the standard.

In the drawings, C is a hopper, around the base of which at suitable places are hooks or projections to engage the material of the top of the sack and hold the sack upright and in operative position. On the side of the hopper C the arm B has its end pivoted at *d* to the lug *e*, and the corresponding end of a similar arm is similarly pivoted on the opposite side of the hopper. The other ends of these arms, respectively, are pivoted at N to opposite sides of the standard A and are held in position by the transverse pivot or bolt passing through the standard and said ends of the arms B. The bracket P, with slot therein, as shown in Fig. 4, is fastened to the standard A by a bolt passing through the slot

and standard and secured by a nut on the opposite side of the standard, as shown at *t* in Fig. 1. This bracket by means of the slot and bolt is adjustable and may be raised and lowered to increase or diminish the pressure of the spring S between the bracket and arms B. Said spring by such pressure may readily be made operative in supporting said arms at the top of the spring in proper position and with such pressure as to render said arms sufficiently yielding and resilient to keep the hopper C in proper position and hold the sack upright and free from slack, so that the sack may be evenly and compactly filled. Inclosed by said spring and supporting the same is the bar D, which passes through the projection of the bracket P to and between the arms B, where the bar is expanded, and is secured between said arms by the pivots *r* or other suitable fastening passing through said arms and bar and holding them firmly together intermediate of the hopper C and standard A. That portion of said bar above said arms is bent outward from said hopper horizontally and upward at its end in the form of a crank. Located centrally on the upper edge of that side of the hopper next to the standard A is the fixed finger F, which is connected to the upper end of the bar D by the link L, which device serves to hold the hopper C level, or in such position as conveniently to receive whatever is being filled into the sack. The connection of the supporting-arms B to the top of the standard A being pivotal will permit the hopper C to rise and fall, subject to regulation in that respect, by shifting the bracket P up or down on the standard to increase or diminish the pressure of the spring S on the supporting-arms B. The sides of the standard A against which the arms B slide in the rise and fall of the hopper C serve as a guide to prevent displacement or deflection of the arms and, in conjunction with the bar D, hold the supporting-arms in alignment and assure support of the hopper in proper relative position in the mechanism when in operation.

In the drawings, H is a holder with fixed base *b*, adapted to receive and support in upright position a filled sack preparatory to emptying it. This ancillary holder is pivoted to the standard A by means of interme-

diate bars E E and braces E' E', attached firmly to the holder. A stop *y* is fixed to the holder and its free end adapted to rest against said standard and prop the holder in position to retain the filled sack to be emptied; but the same object may be attained by attaching the stop to the standard with the free end against the holder. The base *b* of the holder H has a fixed handle *y*, whereby to lift the lower end of the holder. It is obvious that by lifting the holder in this way to sufficient height the contents of the sack contained in the holder will be emptied out and the hopper C, being placed in proper position by the operative mechanism thereof above described, will readily receive and drop such contents into the sack beneath the hopper and fill it in a smooth and compact manner, as above described. The feet *m m m m* are rigidly attached to the standard and radiate therefrom, forming a broad base of support, to obviate danger of the apparatus upsetting when in operation. The feet beneath the hopper are curved to admit the bottom of the sack between them. The standard A and hopper C may be made of any suitable material, but preferably of wood. It is not, however, intended to limit the invention to the use of any particular form or arrangement of minor details nor to the particular manner or means of connecting the related parts of the invention as herein described; but such other suitable means and methods for such purpose and minor details may be used as shall be in harmony with and not exceed the scope of the invention.

The advantages of the invention herein described as a portable, economical, and convenient means and method of handling, sacking, and unsacking grain and other products will be apparent to persons familiar with such business and means used for such purpose without further description than herein given.

What I claim, and desire to secure by Letters Patent, is--

1. A sack-holder comprising a suitable base and standard, a hopper provided with means to engage a sack, arms pivoted to two sides of the hopper, and to two corresponding sides of said standard, a bar between said arms, and pivotally connected therewith, extending down said standard through an adjustable bracket, a supporting-spring consisting of a wire coiled around said bar between said bracket and arms, means of connecting said bar to the upper edge of said hopper, thereby causing the top of the hopper to occupy a horizontal plane, substantially as described, and as and for the purposes specified.

2. A sack-holder comprising a suitable standard, a hopper provided with means to engage a sack, and with external lugs on two of its opposite sides, arms pivoted to said lugs and to the corresponding sides of said standard, a rigid finger on a third side of the hop-

per next to said standard, a bar attached to said standard and opposite to said hopper and finger, a means of connecting said finger and the top of said bar, thereby causing said hopper to occupy a horizontal plane, substantially as described, and as and for the purposes specified.

3. A sack-holder comprising a suitable base and standard, a hopper with downward-converging sides, external lugs on two opposite sides of said hopper, supporting-arms pivoted to said lugs and to corresponding sides of said standard, a bar and spring carried upon the side of said standard intermediate of said hopper and standard, a finger rigidly attached to the side of the hopper, and a link connecting said finger and the top of said bar, substantially as described, and as and for the purposes specified.

4. A sack-holder comprising a hopper, with means to engage and hold open a sack, a suitable base and standard, a pair of arms pivoted to opposite sides of said hopper, and to corresponding sides of said standard, an adjustable support for said arms, comprising a bar pivoted between them, an adjustable bracket and guide for said bar on the side of said standard, and a spring coiled around said bar between said arms and bracket, substantially as described, and as and for the purposes specified.

5. A sack-holder comprising a suitable base and standard, a hopper with lugs carried externally on its ends, swinging arms pivoted to said lugs, and to the corresponding sides of said standard, an upright bar carried upon said standard and intermediate of said arms and pivotally connected therewith, said pivotal connections and related parts holding said arms in alinement and said hopper in operative position, substantially as described, and as and for the purposes specified.

6. In a sack-holder, the combination of a standard with suitable base, a hopper with means of engaging and holding open a sack, lateral arms horizontally disposed, and pivoted to corresponding sides of said hopper and standard, means of connecting said hopper with said standard, and means of supporting said hopper in operative position, an ancillary holder pivoted to said standard opposite said hopper, and adapted to hold upright and carry a filled sack, and with means provided whereby to raise said filled sack sufficiently and in position to cause its contents to pour into said hopper, substantially as described, and as and for the purposes specified.

In testimony whereof I have signed my name to this specification, this 28th day of July, 1902, in the presence of two subscribing witnesses.

EDWARD E. ELLIOTT.

Witnesses:

ORLO L. CLINE,  
J. A. PERKINS.