



- (51) **International Patent Classification:**  
*H04Q 1/02* (2006.01)
- (21) **International Application Number:**  
PCT/IB2013/002029
- (22) **International Filing Date:**  
11 July 2013 (11.07.2013)
- (25) **Filing Language:** English
- (26) **Publication Language:** English
- (30) **Priority Data:**  
61/670,474 11 July 2012 (11.07.2012) US  
61/727,343 16 November 2012 (16.11.2012) US
- (71) **Applicant:** TYCO ELECTRONICS UK LTD. [GB/GB];  
Faraday Road, Dorcan, Swindon SN3 5HH (GB).
- (72) **Inventor:** LAMBOURN, Stephen; 90 The Street, More-  
don, Swindon SN25 3HH (GB).
- (74) **Agent:** PATENTANWÄLTE BRESSEL UND PART-  
NER; Dr. Bernhard Obst, Potsdamer Platz 10, 10785 Ber-  
lin (DE).
- (81) **Designated States** (unless otherwise indicated, for every  
kind of national protection available): AE, AG, AL, AM,

AO, AT, AU, AZ, BA, BB, BG, BH, BN, BR, BW, BY,  
BZ, CA, CH, CL, CN, CO, CR, CU, CZ, DE, DK, DM,  
DO, DZ, EC, EE, EG, ES, FI, GB, GD, GE, GH, GM, GT,  
HN, HR, HU, ID, IL, IN, IS, JP, KE, KG, KN, KP, KR,  
KZ, LA, LC, LK, LR, LS, LT, LU, LY, MA, MD, ME,  
MG, MK, MN, MW, MX, MY, MZ, NA, NG, NI, NO, NZ,  
OM, PA, PE, PG, PH, PL, PT, QA, RO, RS, RU, RW, SC,  
SD, SE, SG, SK, SL, SM, ST, SV, SY, TH, TJ, TM, TN,  
TR, TT, TZ, UA, UG, US, UZ, VC, VN, ZA, ZM, ZW.

- (84) **Designated States** (unless otherwise indicated, for every  
kind of regional protection available): ARIPO (BW, GH,  
GM, KE, LR, LS, MW, MZ, NA, RW, SD, SL, SZ, TZ,  
UG, ZM, ZW), Eurasian (AM, AZ, BY, KG, KZ, RU, TJ,  
TM), European (AL, AT, BE, BG, CH, CY, CZ, DE, DK,  
EE, ES, FI, FR, GB, GR, HR, HU, IE, IS, IT, LT, LU, LV,  
MC, MK, MT, NL, NO, PL, PT, RO, RS, SE, SI, SK, SM,  
TR), OAPI (BF, BJ, CF, CG, CI, CM, GA, GN, GQ, GW,  
KM, ML, MR, NE, SN, TD, TG).

**Published:**

- without international search report and to be republished  
upon receipt of that report (Rule 48.2(g))



WO 2014/009812 A2

(54) **Title:** INDICATING COMMUNICATIONS COMPONENTS VIA ILLUMINATION

(57) **Abstract:** A cable connection system (100, 200, 300) includes a coupling housing (110, 210, 310) defining at least a first port (112, 212, 312); a printed circuit board (120, 220, 320) coupled to the coupling housing; and a communications component (130, 230, 330, 360, 400, 500, 550) sized to be received at the first port of the coupling housing. The printed circuit board (120, 220, 320) includes a light source (125, 225, 325). At least an indication section (135, 235, 335, 365, 450, 515) of the communications component (130, 230, 330, 360, 400, 500, 550) includes (e.g., is formed from or is coated with) a light transmissible material. The indication section (135, 235, 335, 365, 450, 515) is aligned with the light source (125, 225, 325) when the communications component (130, 230, 330, 360) is received at the first port of the coupling housing so that light emitted from the light source (125, 225, 325) illuminates the indication section of the communications component (130, 230, 330, 360, 400, 500).

**INDICATING COMMUNICATIONS COMPONENTS VIA ILLUMINATION****Cross-Reference to Related Applications**

This application is being filed on 11 July 2013, as a PCT International Patent application and claims priority to U.S. Patent Application Serial No. 61/670,474 filed on 11 July 2012 and U.S. Patent Application Serial No. 61/727,343 filed on 16 November 2012, the disclosures of which are incorporated herein by reference in their entireties.

**Background**

Communications services (e.g., fiber optic connectivity and service; copper connectivity and service) are being extended to more and more customers, both commercial and residential. With the increase in use of copper and fiber cables in the communications industry, it is desirable to provide devices with increased termination density. By density, it is meant the number of locations per unit volume or unit area for providing connection on a particular communications device.

With the increased density of communications connections in telecommunications devices, quick identification of the individual connection ports, e.g., for service or for other purposes, presents a challenge, especially in low-light environments. A system for quick identification of the individual ports in a high density distribution environment is desirable.

**Summary**

In accordance with aspects of the disclosure, a cable connection system includes a coupling housing defining at least a first port; a printed circuit board coupled to the coupling housing; and a communications component sized to be received at the first port of the coupling housing. The printed circuit board includes a light source. At least an indication section of the communications component is formed of or coated with a light transmissible material. The indication section is aligned with the light source when the communications component is received at the first port of the coupling housing so that light emitted from the light source illuminates the indication section of the communications component.

In some implementations, the communications component includes a plug connector configured to be received at the first port of the coupling housing. In an example, the indication section includes a boot of the plug connector. In another example, the indication section includes a main body of the plug connector. In other  
5 examples, the communications component includes a dust cap configured to be received at the first port of the coupling housing. In an example, the dust cap is fully formed of the light transmissible material.

In accordance with other aspects of the disclosure, a plug connector arrangement includes a connector body configured to hold a terminated end of a  
10 communications media; and an indication attachment member coupled to the connector body. The indication attachment member is formed of or coated with a light transmissible material that is configured to illuminate when light is shown on the indication attachment member. In certain implementations, the connector body defines a recessed portion and the indication attachment member is configured to fit  
15 over the recessed portion. In certain implementations, the indication attachment member is configured to latch to the connector body. In certain implementations, the indication attachment member includes a first portion that encircles a first end of the connector body and a second portion that extends a distance along a length of the connector body from the first portion.

In accordance with other aspects of the disclosure, a coupler  
20 arrangement includes a coupling housing, a printed circuit board, and a light source. The coupling housing defines at least a first port and includes a first side having an interior surface defining a recess adjacent the first port. The printed circuit board is embedded within the first side of the coupling housing between the interior surface  
25 and an exterior surface of the first side. The light source is coupled to the printed circuit board and aligned with the recess defined in the interior surface of the first side of the coupling housing. The light source is configured to emit light through the recess.

In some implementations, the coupling housing includes an optical  
30 adapter. In other implementations, the coupling housing includes a socket in which electrical contacts are disposed.

In some implementations, the printed circuit board is embedded within the coupling housing. In other implementations, the coupling housing is

mounted to the printed circuit board, which extends beyond the first port of the coupling housing. In an example, light source is mounted to a top surface of the printed circuit board. In another example, the light source is mounted within a recess defined in the printed circuit board. In another example, the light source is  
5 bottom-mounted to the printed circuit board, which defines an aperture sized to enable the emitted light to reach the indication section of the plug connector through the aperture.

In accordance with other aspects of the disclosure, a dust cap configured to be mounted at a port of a coupling housing includes a mounting  
10 portion and a cover portion. The mounting portion is sized and configured to extend through the port of the coupling housing and to secure to an interior of the coupling housing. The mounting portion includes a light transmissible material. The mounting portion includes an enlarged diameter section at the first end. The cover portion is coupled to the mounting portion. The cover portion includes a light  
15 transmissible material. The cover portion has a cross-dimension larger than a cross-dimension of the port so that the cover portion is retained outside of the coupling housing when the mounting portion extends through the port.

In accordance with other aspects of the disclosure, a method for indicating a dust cap at a coupling housing includes sending a control signal to a  
20 light source that aligns with an annular side of the dust cap to emit light while maintaining isolation of the light from any communications media segments disposed within the coupling housing.

A variety of additional inventive aspects will be set forth in the description that follows. The inventive aspects can relate to individual features and  
25 to combinations of features. It is to be understood that both the forgoing general description and the following detailed description are exemplary and explanatory only and are not restrictive of the broad inventive concepts upon which the embodiments disclosed herein are based.

### **Brief Description of the Drawings**

The accompanying drawings, which are incorporated in and constitute a part of the description, illustrate several aspects of the present disclosure. A brief description of the drawings is as follows:

FIG. 1 is a schematic block diagram showing a communications system including a cable connection system and a management system;

FIG. 2 is a schematic block diagram of a portion of the connection system of FIG. 1 showing an example plug connector being received at a port of one of the coupling housings;

FIG. 3 illustrates one example implementation of a cable connection system including a light source mounted at a location spaced from an adapter;

FIG. 4 illustrates another example implementation of a cable connection system including a light source mounted to shine within an interior of an adapter;

FIG. 5 is a perspective view of an example connector housing suitable for use in the connection system of FIG. 4;

FIG. 6 is a perspective view of the connector housing of FIG. 5 with an indicator section shown exploded from the rest of the adapter;

FIG. 7 illustrates an example dust cap suitable for use with the connection system of FIG. 4;

FIG. 8 is a front perspective view of an example SC connector having an indication component;

FIG. 9 is a rear perspective view of the SC connector of FIG. 8;

FIG. 10 is a top plan view of the SC connector of FIG. 8;

FIG. 11 is a perspective view of the SC connector of FIG. 8 with the indication component exploded from a body of the SC connector;

FIG. 12 is a top perspective view of the SC connector body of FIG. 11 with the indication component removed from view;

FIG. 13 is a bottom perspective view of the indication component of FIG. 8;

FIG. 14 is a perspective view of an example LC connector having an indication component;

FIG. 15 is an exploded view of the LC connector of FIG. 14;

FIG. 16 is a top plan view of another example LC connector having an indication component; and

FIG. 17 is a rear perspective view of the LC connector of FIG. 16.

### **Detailed Description**

Reference will now be made in detail to exemplary aspects of the present disclosure that are illustrated in the accompanying drawings. Wherever possible, the same reference numbers will be used throughout the drawings to refer to the same or like parts.

In general, a cable connection system includes a coupling housing defining at least a first port; a light source disposed at the coupling housing; and a communications component sized to be received at the first port of the coupling housing. At least an indication section of the communications component includes (e.g., is formed of, is coated with, etc.) a light transmissible material. The indication section is aligned with the light source when the communications component is received at the first port of the coupling housing so that light emitted from the light source illuminates the indication section of the communications component. In certain examples, the entire communications component is formed of the light transmissible material. When the communications component is removed from the first port, light from the light source illuminates an interior of the first port.

In some implementations, the coupling housing includes an optical adapter (an SC adapter, an LC adapter, an MPO adapter, etc.). In some such implementations, the communications component includes an optical plug connector. In other such implementations, the communications component includes a dust cap. In other implementations, the coupling housing includes an electrical socket (e.g., an RJ jack, a USB jack, etc.). In certain implementations, the communications component includes an electrical plug connector. For the sake of convenience, the following illustrated examples of cable connection systems show optical cable connection systems. It should be understood that these principles can be applied to electrical cable connection systems.

FIG. 1 is a schematic block diagram showing a communications system including a cable connection system 100 and a management system 150. The cable connection system 100 includes one or more coupling housings (e.g., optical adapters, electrical sockets, etc.) 110 that define at least a first port 112. In certain implementations, each coupling housing 110 is configured to couple together two or more segments of communications media (e.g., optical fibers, electrical conductors, etc.). Each port 112 is associated with a light source (e.g., light emitting

diode) 125 that can be utilized to indicate the adapter 110, the port 112, and/or the plug connector received thereat.

The light sources 125 may be operatively associated with the coupling housings 110 via a printed circuit board 120. For example, a light source 125 in certain implementations may be coupled to a printed circuit board 120 to which a coupling housing 110 is coupled without being coupled directly to the coupling housing 110 (see light source 125a in FIG. 1). In another example, a light source 125 in certain implementations may be coupled to a printed circuit board 120 and to an exterior of a coupling housing 110 (see light source 125b in FIG. 1). In another example, a light source 125 in certain implementations may be coupled to a coupling housing 110 so that light emitted by the light source 125 enters an interior of the coupling housing 110 (see light source 125c in FIG. 1).

The management system 150 is coupled to the connection system 100 via the printed circuit board 120. For example, in some implementations, the management system 150 can be implemented as a controller or chip mounted to the printed circuit board 120. In other implementations, all or part of the management system 150 can be implemented by equipment coupled to the printed circuit board and mounted elsewhere. For example, the management system 150 can be implemented remotely and communicatively coupled to the connection system 100 via cables or wireless signals.

The management system 150 includes a processor 152 that implements operations 156 stored in a memory 154. Some example operations 156 that can be stored in memory 154 include an activate operation, which illuminates one or more of the light sources 125, and a deactivate operation, which switches off one or more of the light sources 125. Another example operation 156 that can be stored in memory 154 includes an identify operation, which determines which light source 125 is associated with a particular coupling housing 110 or port 112. The processor 152 can implement the activate or deactivate operations on the identified coupling housing 110 or port 112.

In some implementations, the management system 150 includes a user interface (UI) 158 that enables a user to implement the identify operation. For example, the UI 158 may present the user with a representation (e.g., graphical, textual, numerical, etc.) of the connection system 100 and may enable the user to

select one of the coupling housings 110, ports 112, or other components of the connection system 100. The UI 158 also may enable a user to initiate implementation of the activate or deactivate operations on the light source 125 associated with the selected component. In other implementations, the processor 152 selects the light source 125 to be activated or deactivated based on an analysis of predetermined factors (e.g., error conditions).

FIG. 2 is a schematic block diagram of a portion of the connection system 100 of FIG. 1 showing an example plug connector 130 being received at a port 112 of one of the coupling housings 110. In some implementations, the coupling housing 110 is an optical adapter that mechanically aligns an optical plug connector 130 with another optical plug connector 130 received at an opposite port. In other implementations, the coupling housing 110 is an electrical socket that mechanically aligns an electrical plug connector 130 with conductive contacts housing within the socket.

For ease in viewing, the schematic diagram of FIG. 2 shows an example light source 125 coupled to an exterior of the coupling housing 110. In other implementations, however, the light source 125 can be coupled to an interior of the coupling housing 110 or to a printed circuit board 120 (FIG. 1) coupled to the coupling housing 110. The plug connector 130 being received at the port 112 of the coupling housing 110 terminates a segment 132 of communications media (e.g., an optical fiber, an electrical conductor, etc.). In some implementations, the plug connector 130 includes a main body and a strain-relief boot.

At least a portion of the plug connector 130 is configured to be illuminated by the light source 125. In some implementations, the entire plug connector 130 includes (e.g., is formed of or is coated with) a light transmissible material. In other implementations, the plug connector 130 includes an indication section 135 that generally aligns with the light source 125 when the plug connector 130 is received at the port 112. The light source 125 is configured to illuminate the indication section 135 to identify or otherwise indicate the plug connector 130, port 112, and/or coupling housing 110. For example, the indicator section 135 can be formed at least partially of or coating with a light transmissible material (e.g., glass, opaque plastic, a fluorescent or otherwise luminescent material, etc.). The light transmissible material transfers light from a location (e.g., on the indicator section

135) at which the emitted light reaches the indicator section 135 to one or more locations (e.g., on the indicator section 135) from which a user may discern the light.

In some implementations, the indicator section 135 forms the main body of the connector plug arrangement 130 or a portion thereof. In other implementations, the indicator section 135 forms the strain-relief boot of the connector plug arrangement 130 or a portion thereof. In certain implementations, a majority of the indicator section 135 is disposed outside of the adapter 110 when the connector plug arrangement 130 is received at the first port 112. In certain implementations, the indicator section 135 is fully located outside of the adapter 110 when the connector plug arrangement 130 is received at the first port 112. In other implementations, a majority of the indicator section 135 can be disposed within the adapter port 112.

FIGS. 3-7 illustrate various implementations of connection systems suitable for connection to the management system 150. For convenience, the connections systems of FIGS. 3-7 are implemented as optical connection systems. It should be understood, however, that the principles disclosed herein can be applied to electrical connection systems.

FIG. 3 illustrates one example implementation of a cable connection system 200. The example cable connection system 200 includes an optical adapter 210 defining a port 212 at which a connector plug arrangement 230 can be received. The opposing port of the adapter 210 is not shown for clarity. The adapter 210 is associated with a light source 225. In some implementations, the light source 225 is disposed outside of the adapter 210. In certain implementations, the adapter 210 and the light source 225 are each mounted to a printed circuit board 220. For example, in certain implementations, the light source 225 is spaced along the printed circuit board 220 from the adapter 210.

In some implementations, the printed circuit board 220 can be mounted to a panel, tray, or other surface 240. The adapter 210 can be mounted to an opposite side of the printed circuit board 220 from the panel, tray, or other surface 240. In other implementations, the adapter 210 can be mounted directly to the panel, tray, or other surface 240 and the light source 225 can be spaced along the panel, tray, or other surface 240 from the adapter 210. For example, the light source

225 can be mounted to a printed circuit board 220 that is mounted to the panel, tray, or other surface 240 at a location spaced from the adapter 210.

The connector plug arrangement 230 includes a main housing 234 configured to hold an optical fiber or fiber cable 232 that can be coupled to another optical fiber received at the opposite port. In certain implementations, the connector plug arrangement 230 also includes a strain-relief boot 236 coupled to the main housing 234 to provide strain-relief to the optical fiber or cable 232. The connector plug arrangement 230 may include a holding section 238 at which the optical fiber or cable 232 may be anchored to the connector 230. The connector plug arrangement 230 includes an indicator section 235 that aligns with the light source 225 when the connector plug arrangement 230 is received at the first port 212. In certain implementations, the strain-relief boot 236 includes the indicator section 235. In the example shown in FIG. 3, the entire strain-relief boot 236 forms the indicator section 235.

The light source 225 is mounted relative to the adapter 210 so that light emitted by the light source 225 shines towards the indicator section 235 of the connector plug arrangement 230. In the example shown in FIG. 3, the adapter 210 and the light source 225 are mounted to a printed circuit board 220, which is mounted to a surface 240. In the example shown, the light source 225 is bottom-mounted to the printed circuit board 220 and accommodated by a recess 242 defined in the surface 240. The board 220 defines an aperture 228 through which light emitted from the light source 225 travels to reach the indicator section 235 of the connector plug arrangement 230. In other implementations, however, the light source 225 can be top-mounted or flush-mounted with the printed circuit board 220.

In the example shown in FIG. 3, the adapter 210 is disposed over the printed circuit board 220 at a first location and the light source 225 is mounted to the printed circuit board 220 at a second location spaced from the first location. Light emitted by the light source 225 does not enter the interior of the adapter 210. A portion of the strain-relief boot 236 of the plug connector arrangement 230 aligns with light source 225 when the plug connector arrangement 230 is received at the first port 212 of the adapter 210. Light from the light source 225 illuminates the indicator section 235 of the strain-relief boot 236 when activated. The light from the

light source 225 does not affect communications signals carried over the media segment 232.

In some implementations, the adapter 210 is mounted to the printed circuit board 220. In other implementations, the adapter 210 and the printed circuit board 220 are separately mounted to the surface 240 so that at least part of the board 220 is disposed beneath the adapter 210. Mounting the adapter 210 to the surface instead of to the board 220 facilitates removal of the adapter 210 for replacement, cleaning, and/or enhanced access to the ports.

FIGS. 4-6 illustrate another example implementation of a cable connection system 300. The example cable connection system 300 also includes an optical adapter 310, a light source 325, and a connector plug arrangement 330. The adapter 310 defines a first port 312 for receiving the connector plug arrangement 330. In some implementations, the light source 325 is configured to emit light into the interior of the adapter 310. However, the light source 325 is disposed and oriented to that the light emitted by the light source 325 does not interfere or otherwise affect the communications signals passing over the optical fibers of the connector plug arrangement 330.

In some implementations, the light source 325 is mounted at an interior of the adapter 310. In other implementations, however, the light source 325 is mounted to a printed circuit board 320 coupled to the adapter 310. In certain implementations, a side wall 313 of the adapter 310 defines an aperture 315 through which the light from the light source 325 shines into the adapter 310. In some such implementations, the printed circuit board 320 is embedded within a side wall 313 of the adapter 310 (see FIG. 4). In other such implementations, the printed circuit board 320 extends along an exterior surface of the adapter 310.

The connector plug arrangement 330 includes a main housing 334 configured to hold an optical fiber or fiber cable that can be coupled to another optical fiber received at the opposite port. At least a portion of the main housing 334 extends outwardly from the adapter 310 when the plug connector arrangement 330 is mounted at the port 312. In certain implementations, the connector plug arrangement 330 also includes a strain-relief boot 336 coupled to the main housing 334 to provide strain-relief to the optical fiber or cable. The connector plug

arrangement 330 may include a holding section (not shown) at which the optical fiber or cable may be anchored to the connector 330.

The connector plug arrangement 330 includes an indicator section 335 that aligns with the light source 325 when the connector plug arrangement 330 is received at the first port 312. In some implementations, the indicator section 335 forms part of the main housing 334. In certain implementations, the indicator section 335 forms a separate piece part that can be coupled to the main body 334 (see FIG. 6). At least a first portion 337 of the indicator section 335 is disposed outside of the adapter 310 and a second portion 339 of the indicator section 335 is disposed inside of the adapter 310 when the plug connector arrangement 330 is received at the port 312. Light shining on the first portion 337 of the indicator section 335 is transmitted along the indicator section 335 to the second portion 339 of the indicator section 335.

As shown in FIG. 6, the indicator section 335 can include a piece part that is sized and configured to fit over a mounting section 331 of the main housing 334. In some implementations, the mounting section 331 of the main housing 334 can define a reduced cross-dimension relative to the remainder of the main housing 334. For example, material can be removed from an exterior surface of the main housing 334 to form a recessed or ablated mounting section 331. The indicator section 335 has a thickness that enables an exterior surface of the indicator section 335 to extend flush with an exterior surface of the main housing 334.

In some implementations, the indicator section 335 can be latched, glued, or otherwise secured to the main housing 334. As shown in FIG. 4, a latching nose 339a can snap into a depression 333 defined in mounting section 331 of the housing 334. In certain implementations, the first portion 337 of the indicator member 335 extends around a perimeter of the mounting section 331 and the second portion 339 defines a flange extending outwardly from the first portion 337. In certain implementations, the latching nose 339a is disposed at a distal end of the second portion 339 of the indicator section 335.

FIG. 7 illustrates an example dust cap 360 mounted at the first port 312 of the adapter 310 of the connection system 300 of FIG. 4. At least a portion of the dust cap 360 includes a light transmissible material so that the dust cap 360 or portion thereof can be illuminated by the light source 325. In the example shown,

the entire dust cap 360 is formed of the light transmissible material. In other implementations, however, strips or other sections of the dust cap 360 may be formed of or coated with the light transmissible material. While the dust cap 360 is shown in use with the connection system of FIG. 4, it should be understood, that the dust cap 360 or similar structure can be utilized with other connection systems (e.g., connection system 200 of FIG. 3, electrical connection systems, etc.).

The dust cap 360 is configured to mount at the port 312 so that a first portion 362 remains outside of the adapter 310 and a second portion 364 extends into the adapter 310. For example, a cover portion 362 of the dust cap 360 may be sized to remain outside of the adapter 310 while a mounting portion 364 extends into the port 312. Light emitted from the light source 325 shines on the second portion 364 and is transmitted along the dust cap 360 to the first portion 362. Accordingly, the light source 325 can be utilized to illuminate the dust cap 360 to indicate or identify the port 312 or adapter 310 to the user.

In the example shown in FIG. 7, the adapter 310 includes an optical fiber adapter including a ferrule sleeve 316 that is sized and configured to receive a ferrule of a plug connector arrangement 330. The printed circuit board 320 is embedded in a sidewall of the adapter 310. The second portion 364 of the dust cap 360 is configured to mount over the ferrule sleeve 316 to mount the dust cap 360 to the port 312. In other implementations, the dust cap 360 may be latched or otherwise secured at the adapter port 312. In the example shown, a distal end of the second portion 364 of the dust cap 360 includes an enlarged diameter section 366. In certain implementations, the enlarged diameter section 366 facilitates reception of the light emitted from the light source 325 at the dust cap 360.

FIGS. 8-13 illustrate an example connector plug arrangement 400 having an indication component 450. The example connector plug arrangement 400 includes a body 410 having a front 401, a rear 402, a first side 403, a second side 404, a top 405, and a bottom 406. A ferrule 412 holding an optical fiber extends from the front 401 of the body 410. A strain-relief boot 416 couples to or extends from the rear 402 of the body 410. The body 410 includes a grip section 414 by which a user can grasp the plug connector 400 and a connection section 418 at which the plug connector 400 is secured to an optical adapter or other receptacle.

The indication component 450 is mounted to the plug connector body 410. In some implementations, the indication component 450 is mounted to extend towards the rear 402 of the body 410. In certain implementations, the indication component 450 is configured to extend over the boot 416. In other implementations, the indication component 450 is configured to extend over only the body 410. In some implementations, the indication component 450 extends from an intermediate portion of the body 410 to the rear 402 of the body 410 (e.g., see FIG. 10).

The indication component 450 extends from a first end 451 to a second end 452 (FIG. 10). The indication component 450 includes a first section 453 at the first end 451, an intermediate section 454, a first arm 455 at the second end 452, and a second arm 456 at the second end 452. In the example shown, the first and second arms 455, 456 branch off in opposite directions from the intermediate section 454. The first section 453 is narrow than the intermediate section 454. Light shown onto the first section 453 of the indication component 450 travels from the first section, through the intermediate section 454, and along the branch arms 455, 456.

In some implementations, the light causes the indication component 450 to glow. In certain implementations, the indication component 450 is configured so that light is more intensely visible at certain locations than from the rest of the indication component 450. In the example shown, the light is more intensely visible at the distal end 457 of the first branch arm 455, at the distal end 458 of the second branch arm 456, and at the intersection 459 of the two arms 455, 456. Accordingly, the light is visible at least from the rear 402 of the plug connector (e.g., via the intersection 459) and from the sides 403, 404 of the plug connector 400 (e.g., via the arm distal ends 457, 458).

In some implementations, the indication component 450 is formed at least partially from a clear or translucent material (e.g., glass, plastic, etc.). The light traveling through the translucent material of the indication component 450 can be white light or colored light. In other implementations, the indication component 450 can be formed from a material tinted one or more colors, but sufficiently translucent to enable light to travel through the material.

FIGS. 11-13 show how one example indication component 450 can be mounted to one example plug connector 400. The connector body 410 includes a

retention arrangement 430 at which the indication component 450 is disposed. The retention arrangement 430 includes a channel 431 in which the first section 453 and intermediate section 454 can seat. The retention arrangement 430 also includes at least a first bridge 432 that extends over the channel 431. A portion of the indication component 450 extends under the first bridge 432 so that the first bridge 432 holds the indication component 450 to the connector body 410.

In certain implementations, the retention arrangement 430 also includes a second bridge 434. In some implementations, the first bridge 432 and the second bridge 434 extend over the intermediate section 434 of the indication component 450. In other implementations, the first bridge 432 extends at least partially over the arms 455, 456 of the indication component 450. In still other implementations, the second bridge extends over the first section 453. In certain implementations, the first bridge 432 is wider than the second bridge 434.

In some implementations, the retention arrangement 430 includes latch members 435 that extend upwardly from the connector body 410. For example, one or more latch members 435 can extend upwardly from the top 405 of the connector body 410. In certain implementations, the latch members 435 define a ramped surface facing towards the rear 402 of the connector body 410 and an engagement surface facing towards the front 401 of the body 410. The indication component 450 includes a corresponding set of latch teeth 460 that extend downwardly from a bottom of the indication component 450. The indication component 450 also defines notches 462 (FIG. 13) that align with notches 438 defined by the connector body 410. In the example shown, internal surfaces of the connector body 410 define the notches 438, which are sized and configured to receive notched portions 462 of the branch arms 455, 456 of the indication component 450.

To mount the indication component 450 to the connector body 410, the first end 451 of the indication component 450 is routed through the first and second bridge 432, 434 from the rear 402 of the body 410. The first section 453 and intermediate section 454 of the indication component 450 are slid along the channel 431 of the connector body 410 while the component 450 moves under the bridges 432, 434. As the indication component 450 slides forwardly, the latch teeth 460 of the component 450 cam over the ramped surfaces of the latch members 435 until

they snap-over the latch members 435 and abut the engagement surfaces of the latch members 435. Accordingly, the latch members 435 lock the indication component 450 to the connector body 410.

FIGS. 14-17 illustrate various implementations of LC connectors having indication components. An LC connector includes a flexible latch 518 that is biased away from the connector. The latch 518 facilitates securing the LC connector to an adapter port. In certain implementations, the LC connector includes a trigger 519 that extends over part of the latch 518 to facilitate depressing the latch 518. In some implementations, the body of the LC connector is a single-piece housing in which a ferrule hub and spring mount. In other implementations, the body of the LC connector includes two housing pieces.

FIGS. 14 and 15 show one example LC connector 500 including a body 511, a ferrule hub 526, and a spring 529. The body 511 includes a front housing piece 512 and a rear housing piece 513. In the example shown, the latch 518 is disposed on the front housing piece 512 and the trigger 519 is disposed on the rear housing piece 513. The ferrule hub 526 includes a ferrule 527, a shoulder 533, and a spring mounting section 523. The ferrule hub 526 mounts in the front housing piece 512 so that a distal tip 528 of the ferrule 527 extends forwardly through an opening 521 in the front housing piece 512. A dust plug 532 can be mounted over the distal tip 528. The spring 529 seats around the spring mounting section 523 of the hub 526 so that a first end of the spring 529 abuts the shoulder 533 of the hub 526.

The rear housing piece 513 attaches to the front housing piece 512 to enclose the spring so that a second end of the spring 529 extends through an opening 522 and abuts an internal shoulder defined in the rear housing piece 513. In certain implementations, the front housing piece 512 defines openings 516 and the rear housing piece 513 defines a front extension 514 having protruding lugs 517 sized to fit in the openings 516 of the front housing piece 512. A cable retention section 531 extends rearwardly from the rear housing piece 513. The cable retention section 531 is configured to facilitate crimping or otherwise securing an optical cable to the rear housing piece 513.

In accordance with some aspects of the disclosure, the LC connector 500 can include an indication component 515. In some implementations, one or

more parts of the LC connector 500 can be formed of a light transmissible material. For example, the rear housing piece 513 can be formed of a light transmissible material and function as the indication component 515. In such implementations, light from an LED (e.g., mounted within an adapter, mounted to a tray circuit board, etc.) can shine towards and illuminate at least portions of the rear housing piece 513. In other implementations, the front housing piece 512 can be formed of a light transmissible material and function as the indication component 515. In still other implementations, a light component, such as light component 450, can be disposed on the LC connector 500.

FIGS. 16 and 17 illustrate another example rear housing 550 suitable for use with the LC connector 500. The rear housing 550 includes a main body 554 on which the trigger 519 is disposed. A strain-relief boot 556 extends rearwardly from the main body 554. An optical cable 580 terminated by the LC connector can extend rearwardly through the boot 556. The main body 554, trigger 519, and boot 556 form a single piece configured to mount to a front LC housing (e.g., the front housing piece 512 of the LC connector 500 of FIGS. 14-15).

In some implementations, at least a portion of the rear housing 550 is formed from a light transmissible material. In such implementations, light from an LED (e.g., mounted within an adapter, mounted to a tray circuit board, etc.) can shine towards a bottom of the rear housing 550 and illuminate at least portions of the rear housing 550. In an example, main body 554 is formed from a light transmissible material. In another example, the boot 556 is formed from a light transmissible material. In another example, the main body 554 and the boot 556 are formed from a light transmissible material.

The above specification and examples provide a complete description of the structure, manufacture, and use of the invention. Since many embodiments of the invention can be made without departing from the spirit and scope of the disclosure, the invention resides in the claims hereinafter appended.

**List of Reference Numerals and Corresponding Features**

100	cable connection system
110	coupling housing
112	first port
120	printed circuit board
125	light source
125a, 125b, 125c	example light sources
130	plug connector
132	communications media segment
135	indicator section
150	management system
152	processor
154	memory
156	operations
158	user interface
200	cable connection system
210	optical adapter
212	port
220	printed circuit board
225	light source
230	connector plug arrangement
232	optical fiber or fiber cable
234	main housing
235	indicator section
236	strain-relief boot
238	holding section
240	surface
242	recess
300	cable connection system
310	optical adapter
312	port
313	side wall

315	aperture
316	ferrule sleeve
320	printed circuit board
325	light source
330	connector plug arrangement
331	mounting section
333	depression
334	main housing
335	indicator section
336	strain-relief boot
337	first portion
339	second portion
339a	latching nose
360	dust cap
362	cover portion
364	mounting portion
365	indicator section
366	enlarged diameter section
400	connector plug arrangement
401	front
402	rear
403	first side
404	second side
405	top
406	bottom
410	connector body
412	ferrule
414	grip section
416	boot
418	connection section
430	retention arrangement
431	channel
432	first bridge

433	recessed section
434	second bridge
435	latch members
438	notches
450	indication component
451	first end
452	second end
453	first section
454	intermediate section
455	first arm
456	second arm
457	distal end of first arm
458	distal end of second arm
459	intersection of arms
460	latch teeth
462	notches
500	LC connector
511	connector body
512	a front housing piece
513	a rear housing piece
514	front extension
516	openings
517	lugs
518	latch
519	trigger
521	opening
526	a ferrule hub
527	ferrule
528	distal tip
529	spring
531	cable retention section
532	dust plug
533	shoulder

550	rear housing piece
554	main body
556	boot

What is claimed is:

1. A cable connection system (100, 200, 300) comprising:  
a coupling housing (110, 210, 310) defining at least a first port (112, 212,  
5 312);  
a printed circuit board (120, 220, 320) coupled to the coupling housing (110,  
210, 310), the printed circuit board including a light source (125, 225, 325); and  
a communications component (130, 230, 330, 360, 400, 500) sized to be  
received at the first port (112, 212, 312) of the coupling housing (110, 210, 310), at  
10 least an indication section (135, 235, 335, 365, 450, 515) of the communications  
component (130, 230, 330, 360, 400, 500) including a light transmissible material,  
the indication section (135, 235, 335, 365, 450, 515) being aligned with the light  
source (125, 225, 325) when the communications component (130, 230, 330, 360,  
400, 500) is received at the first port of the coupling housing so that light emitted  
15 from the light source (125, 225, 325) illuminates the indication section (135, 235,  
335, 365, 450, 515) of the communications component (130, 230, 330, 360, 400,  
500).
2. The cable connection system (100, 200, 300) of claim 1, wherein the  
20 communications component (130, 230, 330, 360, 400, 500) includes a plug  
connector (130, 230, 330, 400, 500) configured to be received at the first port (112,  
212, 312) of the coupling housing (110, 210, 310).
3. The cable connection system (100, 200, 300) of claim 2, wherein the  
25 indication section (135, 235, 335, 365, 450, 515) includes a boot (236, 336, 526) of  
the plug connector (130, 230, 330, 400, 500).
4. The cable connection system (100, 200, 300) of claim 2, wherein the  
indication section (135, 235, 335, 365, 450, 515) includes a body (234, 334, 410,  
30 511, 554) of the plug connector (130, 230, 330, 400, 500).
5. The cable connection system (100, 200, 300) of claim 2, wherein the  
indication section (135, 235, 335, 365, 450, 515) includes a separate piece (450)

mounted to a body (234, 334, 410, 511, 554) of the plug connector (130, 230, 330, 400, 500).

6. The cable connection system (100, 200, 300) of claim 1, wherein the  
5 communications component (130, 230, 330, 360, 400, 500) includes a dust cap (360) configured to be received at the first port (112, 212, 312) of the coupling housing (110, 210, 310).

7. The cable connection system (100, 200, 300) of claim 1, wherein the  
10 coupling housing (110, 210, 310) includes an optical adapter, which also defines a second port axially aligned with the first port (112, 212, 312).

8. The cable connection system (100, 200, 300) of claim 1, wherein the  
coupling housing (110, 210, 310) includes a socket in which electrical contacts are  
15 disposed, the electrical contacts being accessible through the first port (112, 212, 312).

9. The cable connection system (100, 200, 300) of claim 1, wherein the printed  
circuit board (120, 220, 320) is embedded within the coupling housing (110, 210,  
20 310).

10. The cable connection system (100, 200, 300) of claim 1, wherein the  
coupling housing (110, 210, 310) is mounted to the printed circuit board (120, 220,  
320), the printed circuit board (120, 220, 320) extending beyond the first port (112,  
25 212, 312) of the coupling housing (110, 210, 310).

11. The cable connection system (100, 200, 300) of claim 1, wherein the light  
source (125, 225, 325) is mounted to a top surface of the printed circuit board (120,  
220, 320).

30

12. The cable connection system (100, 200, 300) of claim 1, wherein the light  
source (125, 225, 325) is mounted within a recess defined in the printed circuit  
board (120, 220, 320).

- 13 The cable connection system (100, 200, 300) of claim 1, wherein the light  
source (125, 225, 325) is bottom-mounted to the printed circuit board (120, 220,  
320), which defines an aperture (228) sized to enable the emitted light to reach the  
5 indication section (135, 235, 335, 365, 450, 515) of the communications component  
(130, 230, 330, 360) through the aperture (228).
14. A coupler arrangement comprising:  
a coupling housing (110, 210, 310) defining at least a first port (112, 212,  
10 312), the coupling housing (110, 210, 310) including a first side (313) having an  
interior surface defining a recess (315) adjacent the first port (112, 212, 312);  
a printed circuit board (120, 220, 320) embedded within the first side (313)  
of the coupling housing (110, 210, 310) between the interior surface and an exterior  
surface of the first side (313); and  
15 a light source (125, 225, 325) coupled to the printed circuit board (120, 220,  
320) and aligned with the recess (315) defined in the interior surface of the first side  
(313) of the coupling housing (110, 210, 310), the light source (125, 225, 325) being  
configured to emit light through the recess (315).
- 20 15. The coupler arrangement of claim 14, wherein the coupling housing (110,  
210, 310) includes an optical adapter, which also defines a second port axially  
aligned with the first port (112, 212, 312).
16. The coupler arrangement of claim 14, wherein the coupling housing (110,  
25 210, 310) includes a socket in which electrical contacts are disposed, the electrical  
contacts being accessible through the first port (112, 212, 312).
17. The coupler arrangement of claim 14, wherein the light source (125, 225,  
325) is mounted to a top surface of the printed circuit board (120, 220, 320).  
30
18. The coupler arrangement of claim 14, wherein the light source (125, 225,  
325) is mounted within a recess defined in the printed circuit board (120, 220, 320).

19. The coupler arrangement of claim 14, wherein the coupling housing defines a second port at which a second light source (125, 225, 325) is mounted.
20. A plug connector (130, 230, 330, 400, 500) comprising:  
5 a connector body (234, 334, 410, 511, 551) configured to hold a terminated end of a communications media (232, 332, 580); and  
an indication attachment member (235, 335, 450, 550) coupled to the connector body (234, 334, 410, 511), at least a portion of the indication attachment member (235, 335, 450, 550) including a light transmissible material that is  
10 configured to illuminate when light is shown on the indication attachment member (235, 335, 450, 550).
21. The plug connector of claim 20, wherein the indication attachment member (235, 335, 450, 550) includes a boot (236, 556) configured to provide strain relief to  
15 the communications media (232, 332, 580).
22. The plug connector of claim 20, wherein the connector body (234, 334, 410, 511) defines a recessed portion (331, 431) and the indication attachment member (235, 335, 450, 550) is configured to fit over the recessed portion (331, 431).  
20
23. The plug connector of claim 22, wherein the indication attachment member (235, 335, 450, 550) is configured to latch to the connector body (234, 334, 410, 511).
24. The plug connector of claim 22, wherein the indication attachment member (235, 335, 450, 550) includes a first portion (337) that encircles a first end of the connector body (234, 334, 410, 511) and a second portion (339) that extends a distance along a length of the connector body (234, 334, 410, 511) from the first portion (337).  
25
25. The plug connector of claim 22, wherein the indication attachment member (235, 335, 450, 550) includes a first arm (455) and a second arm (456) that branch out from a trunk (454).  
30

26. The plug connector of claim 20, wherein the communications media (232, 332, 580) includes an optical fiber.
- 5 27. The plug connector of claim 26, wherein the plug connector (130, 230, 330, 400, 500) includes an SC plug connector.
28. The plug connector of claim 26, wherein the plug connector (130, 230, 330, 400, 500) includes an LC plug connector.
- 10 29. The plug connector of claim 20, wherein the communications media (232, 332, 580) includes an electrical conductor.
30. A dust cap (360) for mounting at a port (112, 212, 312) of a coupling  
15 housing (110, 210, 310), the dust cap comprising:  
a mounting portion (364) extending from a first end to a second end, the mounting portion (364) being sized and configured to extend through the port (112, 212, 312) of the coupling housing (110, 210, 310) and to secure to an interior of the coupling housing (110, 210, 310), the mounting portion (364) includes a light  
20 transmissible material, the mounting portion (364) including an enlarged diameter section at the first end; and  
a cover portion (362) coupled to the second end of the mounting portion (364), the cover portion (362) including the light transmissible material, the cover portion (362) having a cross-dimension larger than a cross-dimension of the port so  
25 that the cover portion (362) is retained outside of the coupling housing (110, 210, 310) when the mounting portion (364) extends through the port (112, 212, 312).
31. A method for indicating a dust cap (360) at a coupling housing (110, 210, 310) that is configured to optically couple communications media segments (132,  
30 232, 332, 580), the method comprising:  
sending a control signal to a light source (125, 225, 325) that aligns with an annular side of the dust cap (360) to emit light while maintaining isolation of the

light from any communications media segments (132, 232, 332, 580) disposed within the coupling housing (110, 210, 310).

32. The method of claim 31, further comprising sliding the dust cap (360) over a  
5 ferrule sleeve (316) of the coupling housing (110, 210, 310).

33. The method of claim 32, wherein sliding the dust cap (360) over the ferrule sleeve (316) comprises sliding the dust cap (360) into the coupling housing (110, 210, 310) until an enlarged diameter portion of the dust cap (360) aligns with the  
10 light source (125, 225, 325).

34. A plug connector (130, 230, 330, 400, 500) comprising a connector body (234, 334) configured to hold a terminated end of a communications media (232, 332, 580), at least a portion of the connector body (234, 334, 410, 511, 550) includes  
15 a light transmissible material that is configured to illuminate when light is shown on the light transmissible material.

35. The plug connector (130, 230, 330, 400, 500) of claim 34, wherein the portion of the connector body (234, 334, 410, 511, 550) includes a rear housing  
20 piece (513, 554).

36. The plug connector (130, 230, 330, 400, 500) of claim 34, wherein the portion of the connector body (234, 334, 410, 511, 550) includes a boot (336, 556).

25 37. The plug connector (130, 230, 330, 400, 500) of claim 34, wherein the portion of the connector body (234, 334, 410, 511, 550) includes an indicator component (450) mounted to the connector body (234, 334, 410, 511, 550).

38. The plug connector of claim 34, wherein the plug connector (130, 230, 330,  
30 400, 500) includes an SC plug connector.

39. The plug connector of claim 34, wherein the plug connector (130, 230, 330, 400, 500) includes an LC plug connector.

FIG. 1

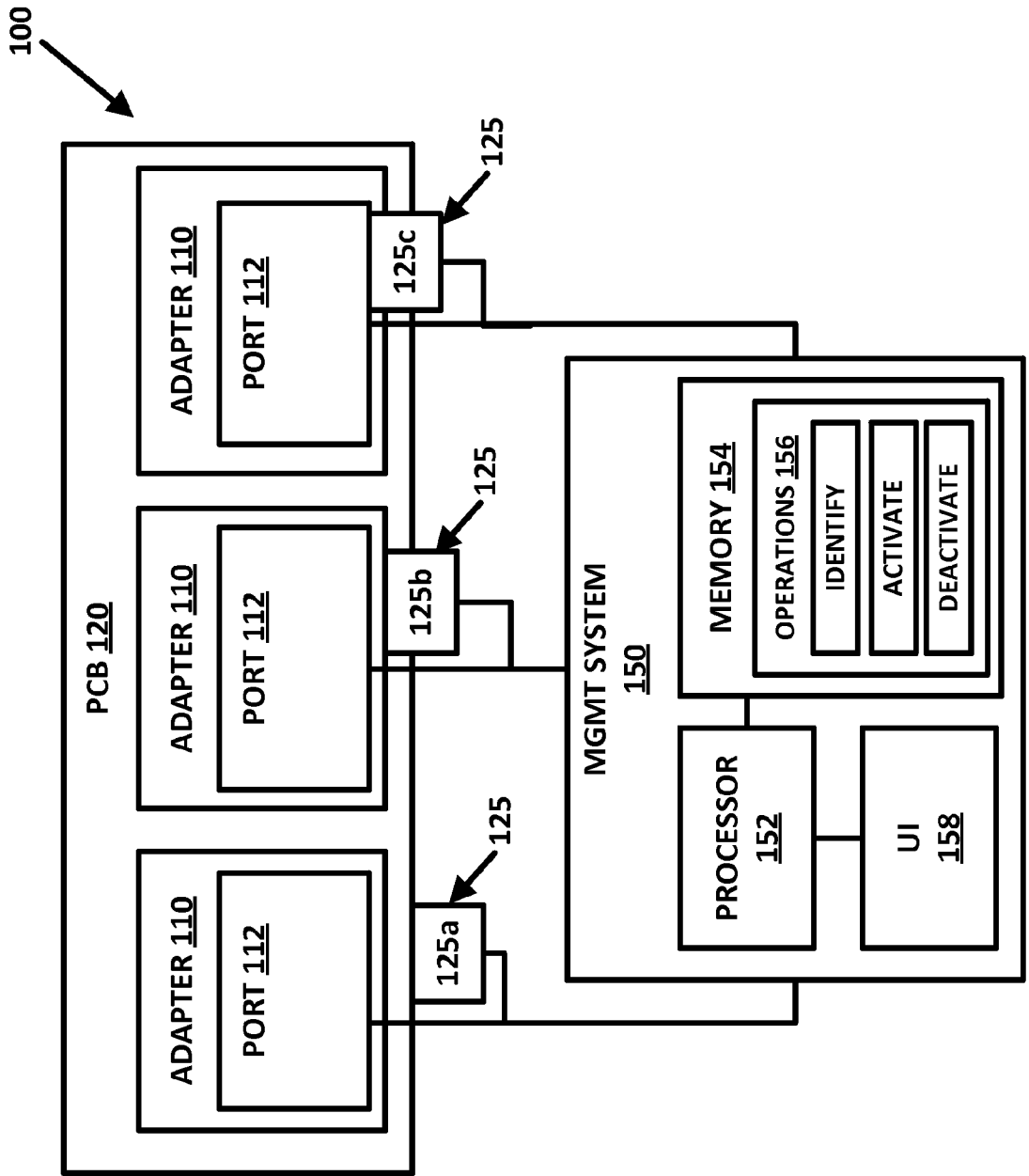

**FIG. 2**

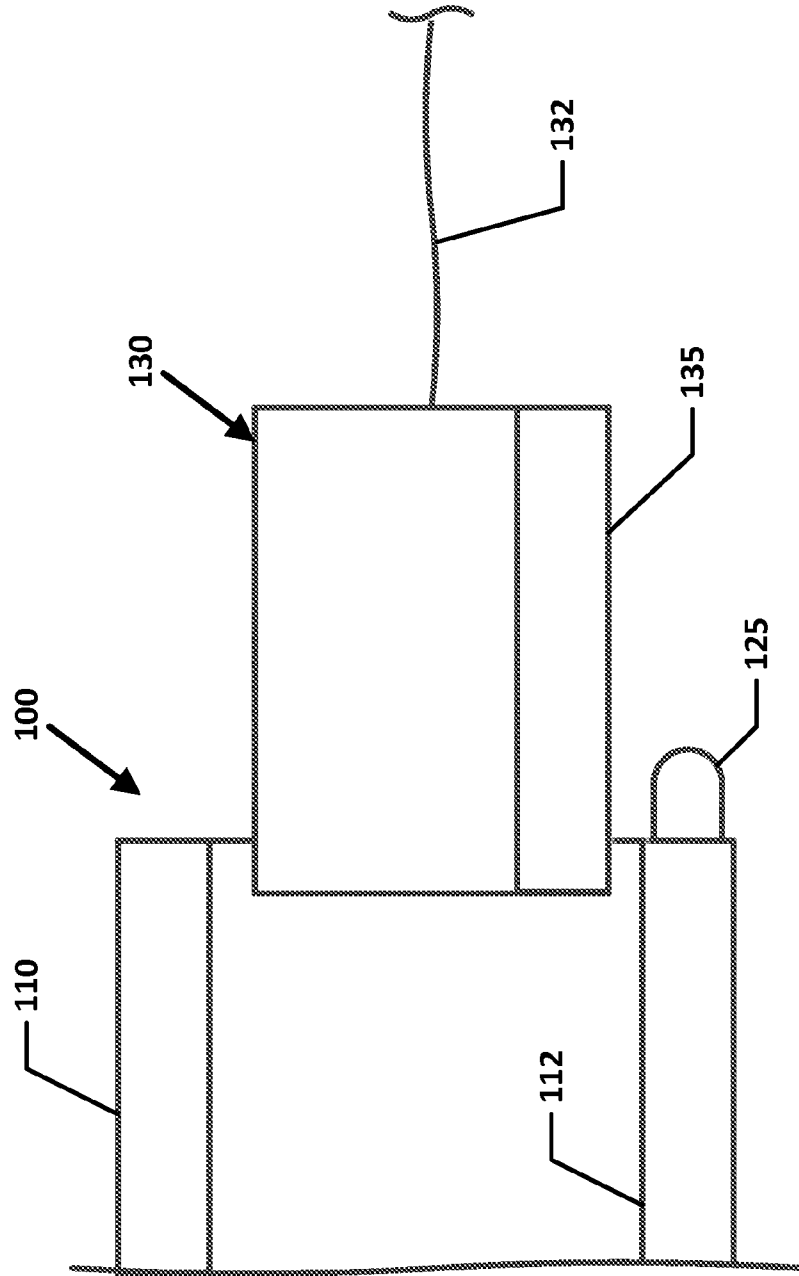

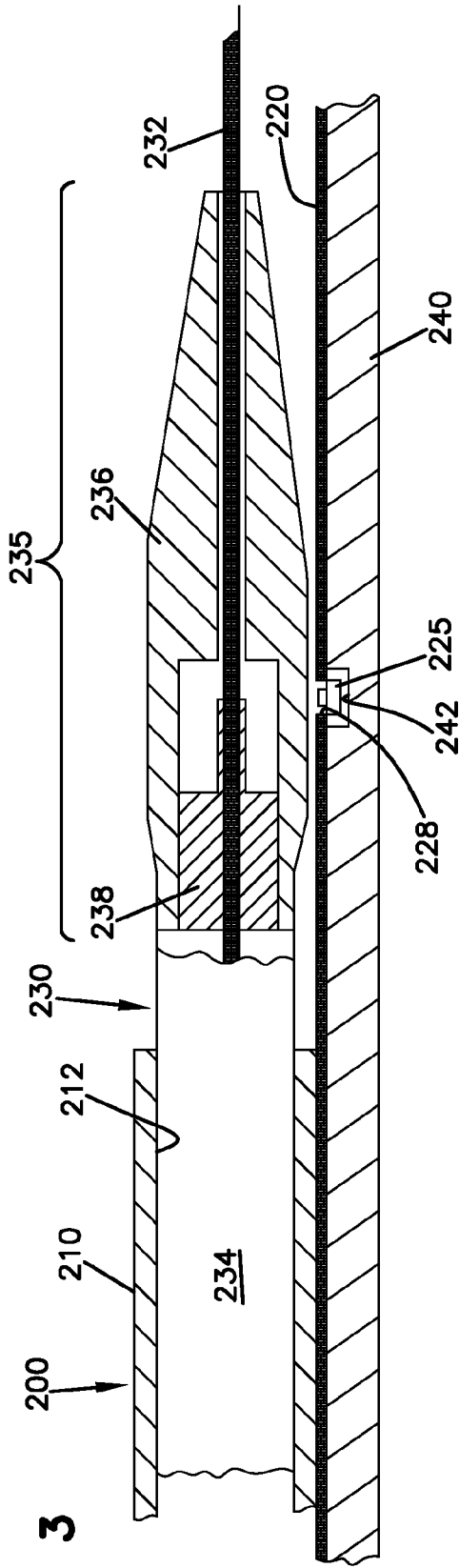

FIG. 3

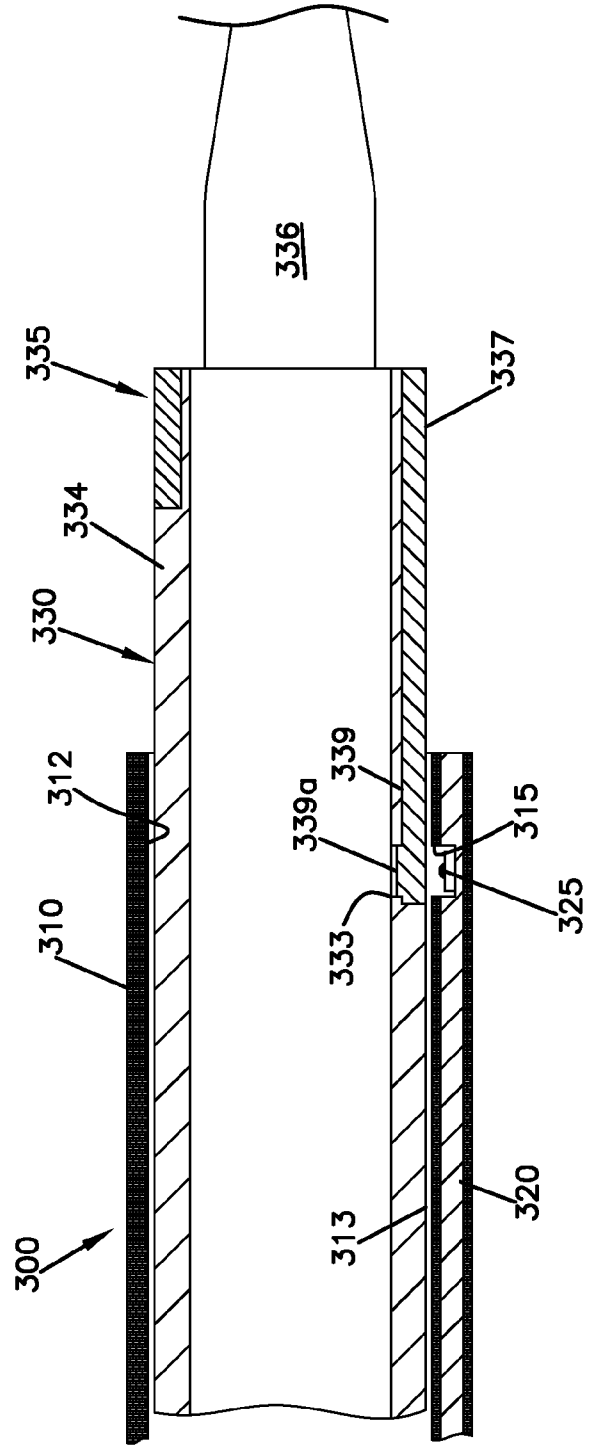

FIG. 4

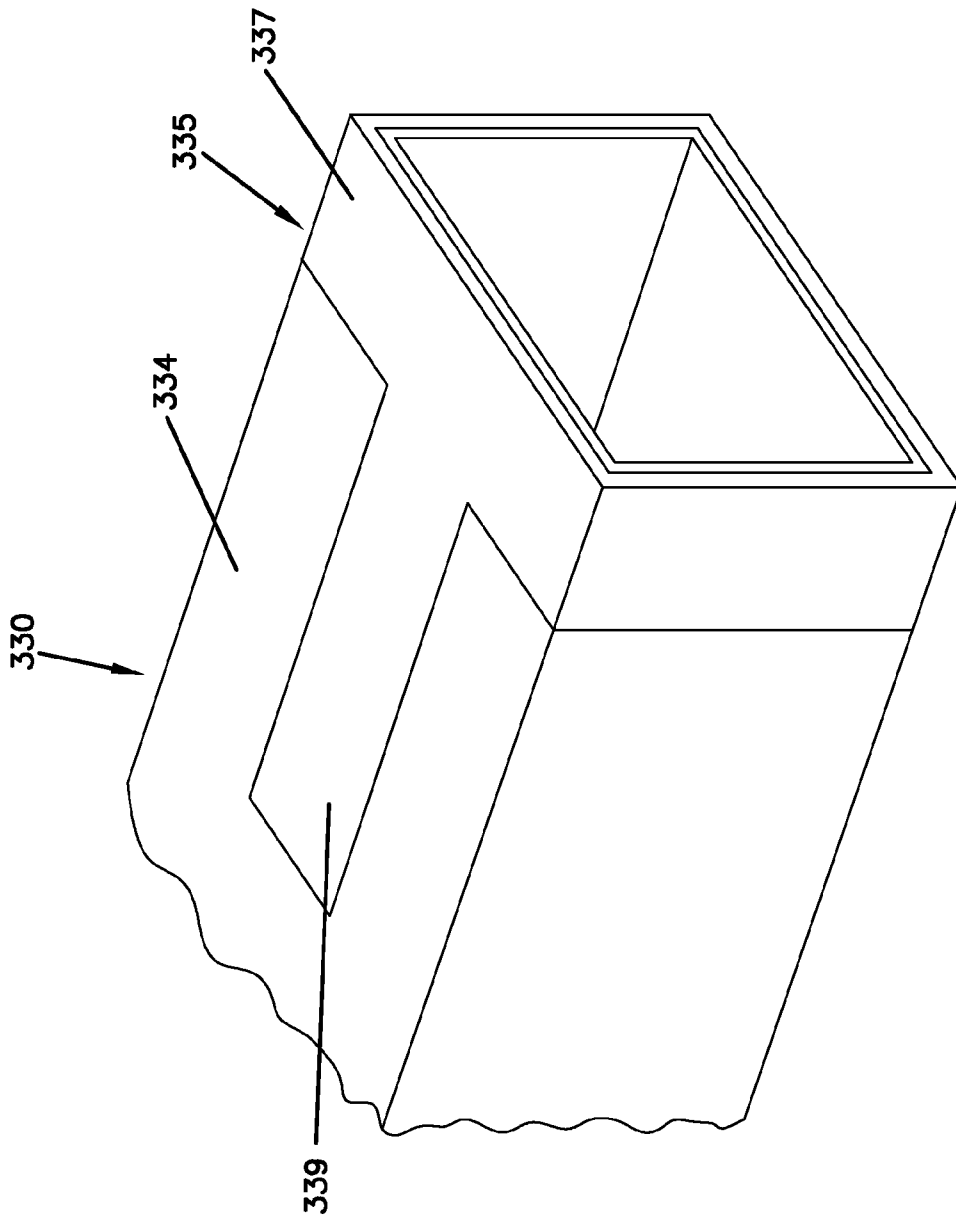

FIG. 5

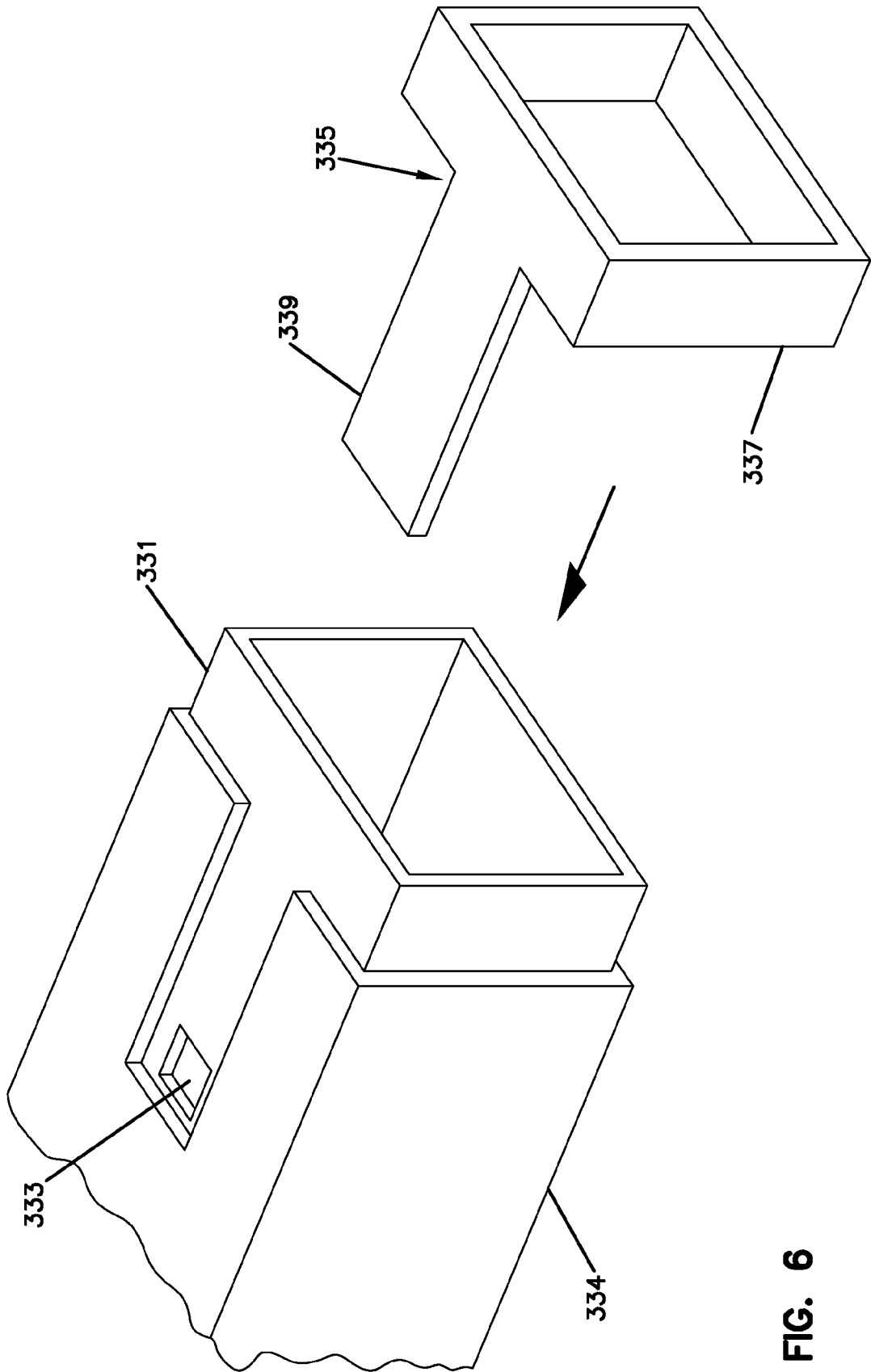
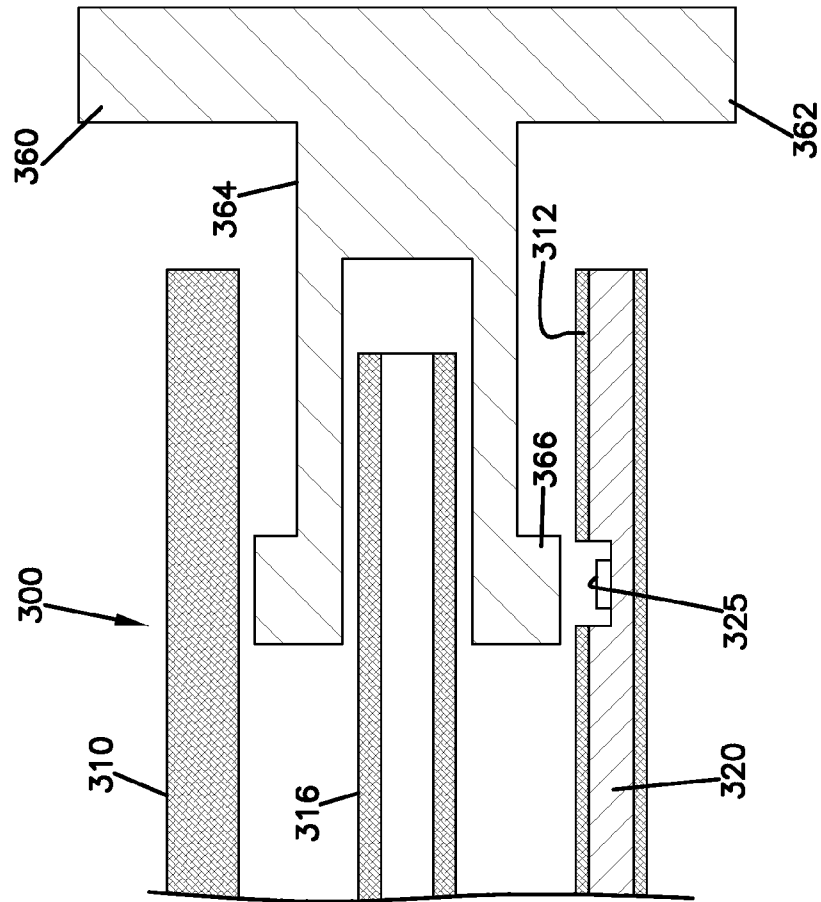

FIG. 6

FIG. 7



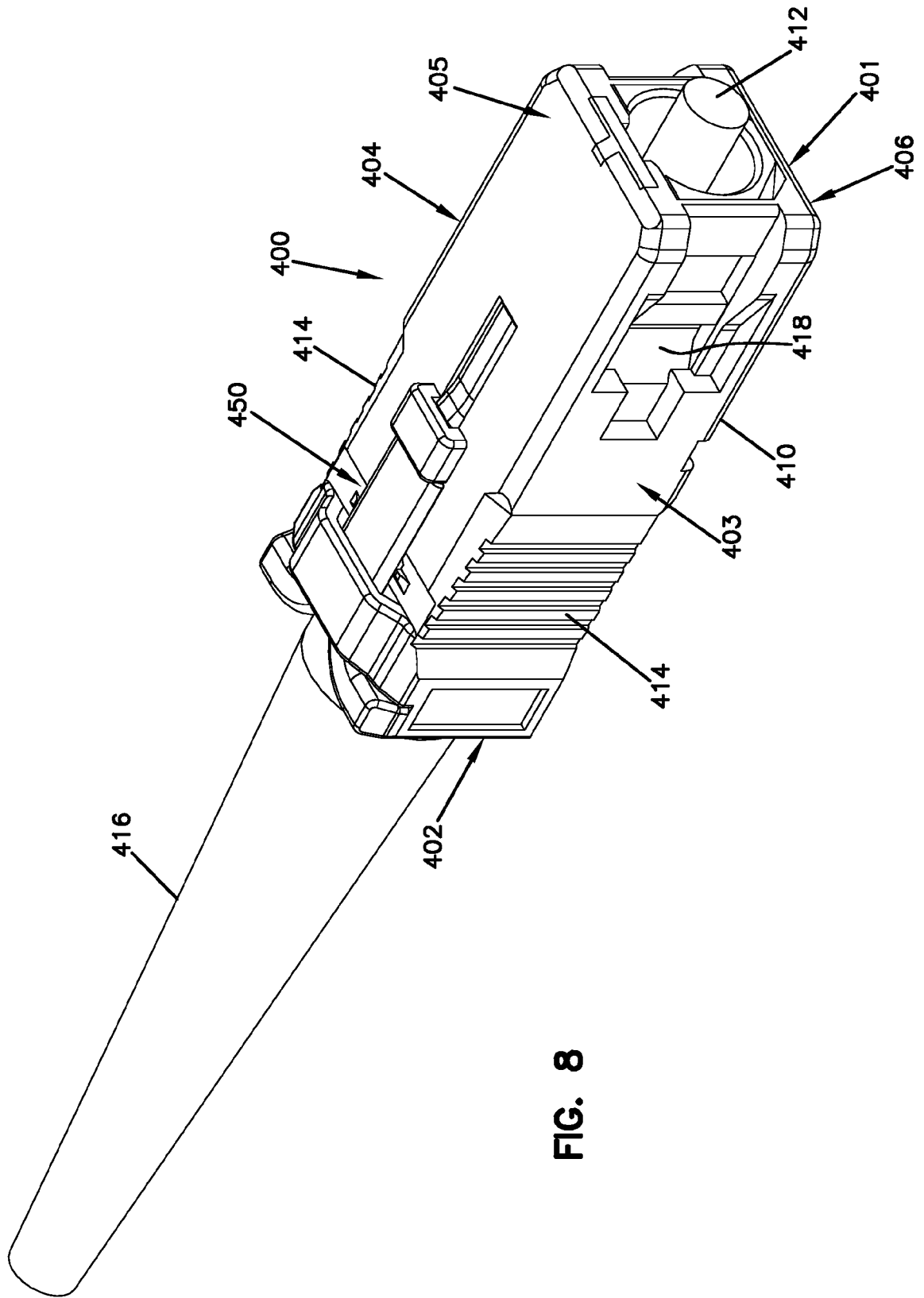

FIG. 8

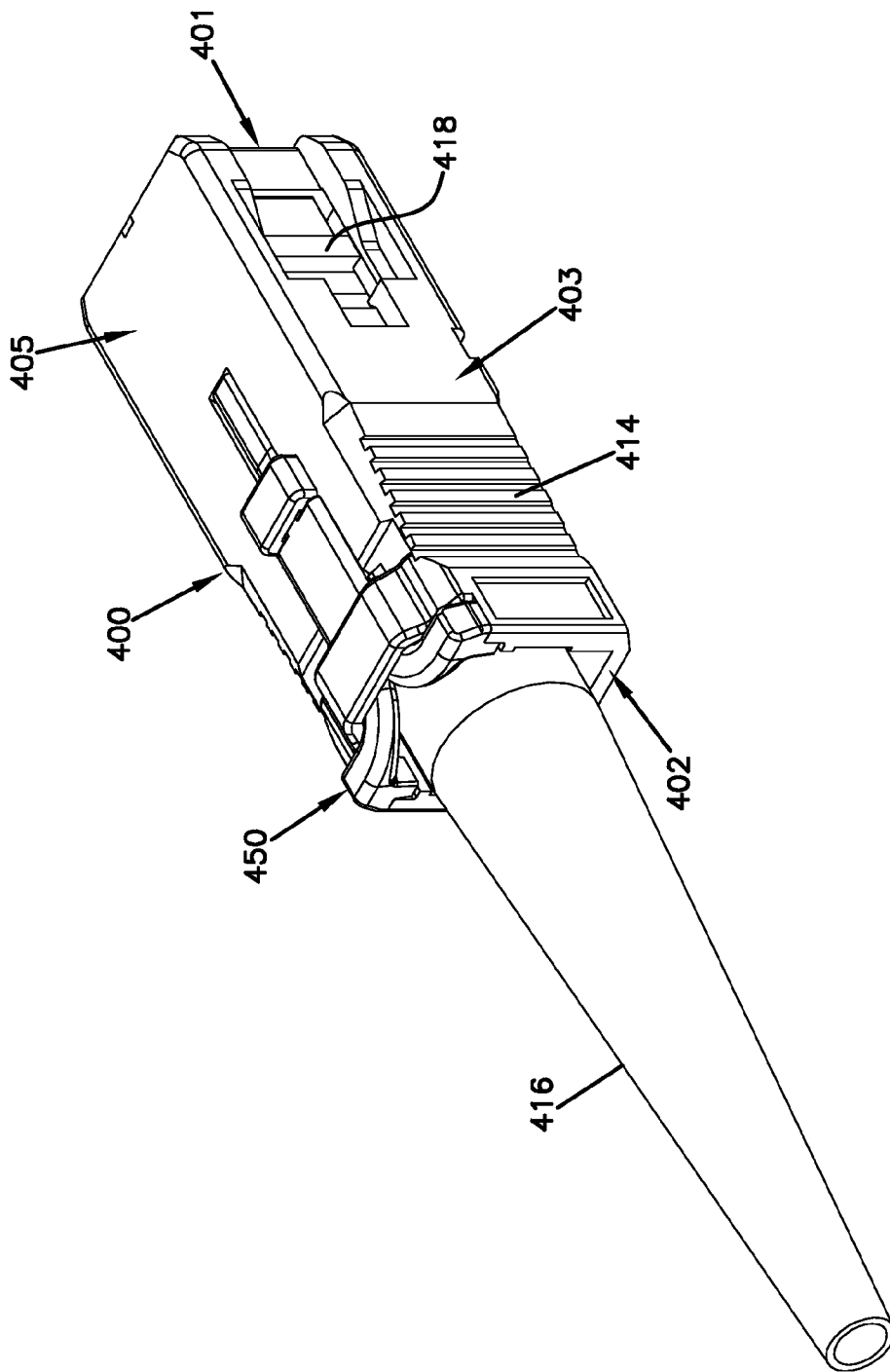
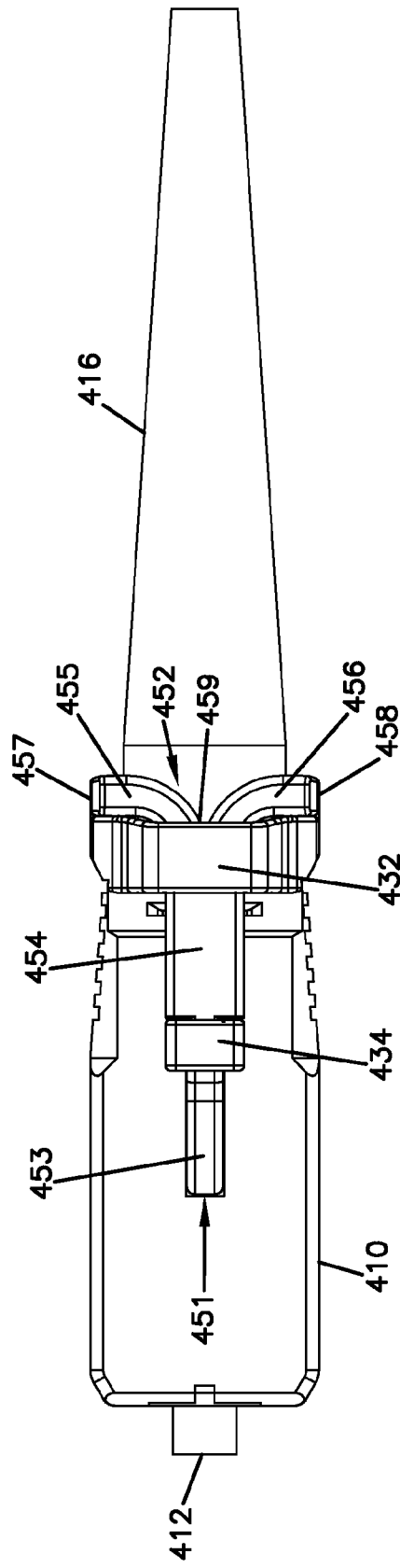

FIG. 9

FIG. 10



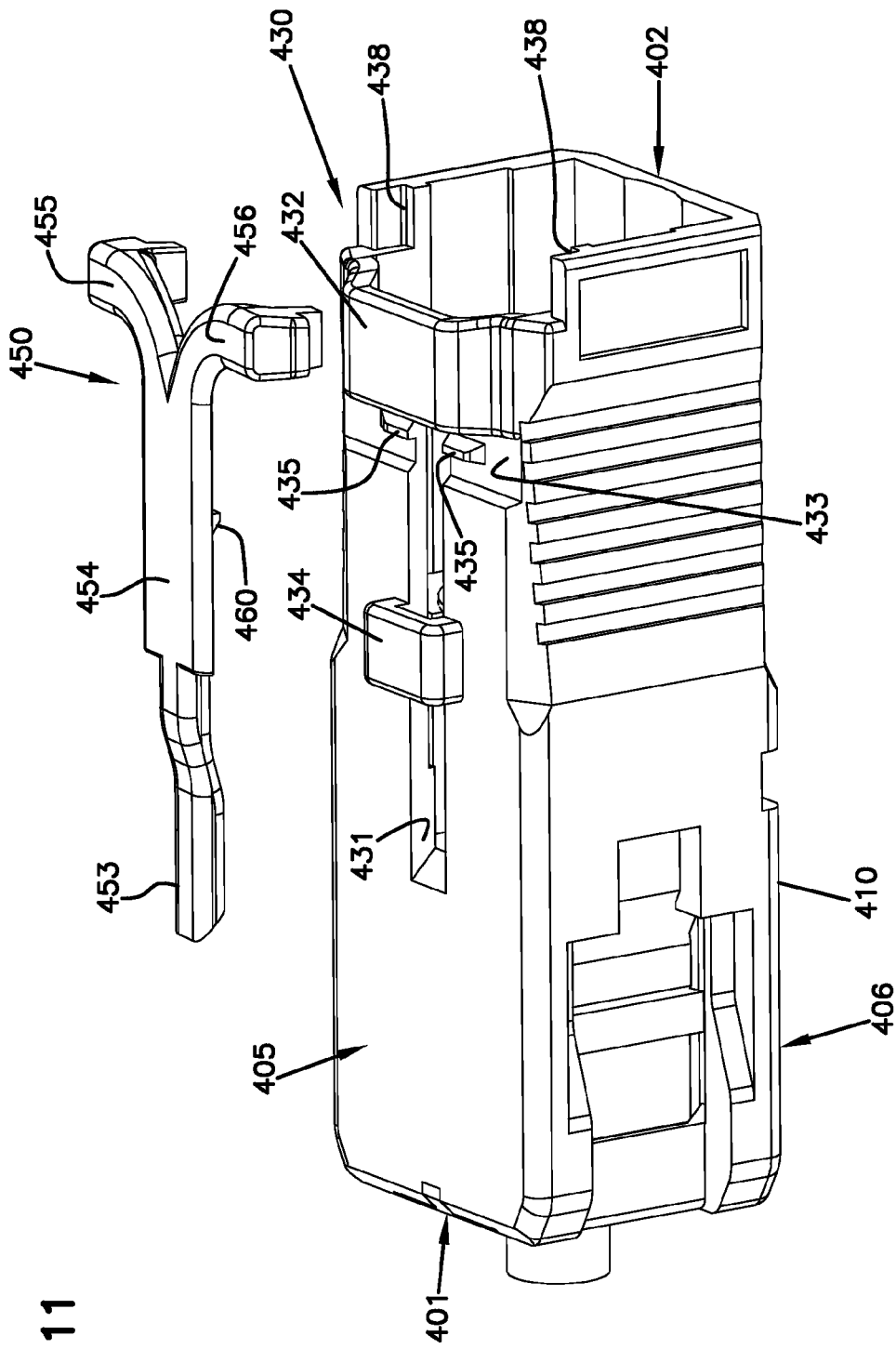

FIG. 11

FIG. 12

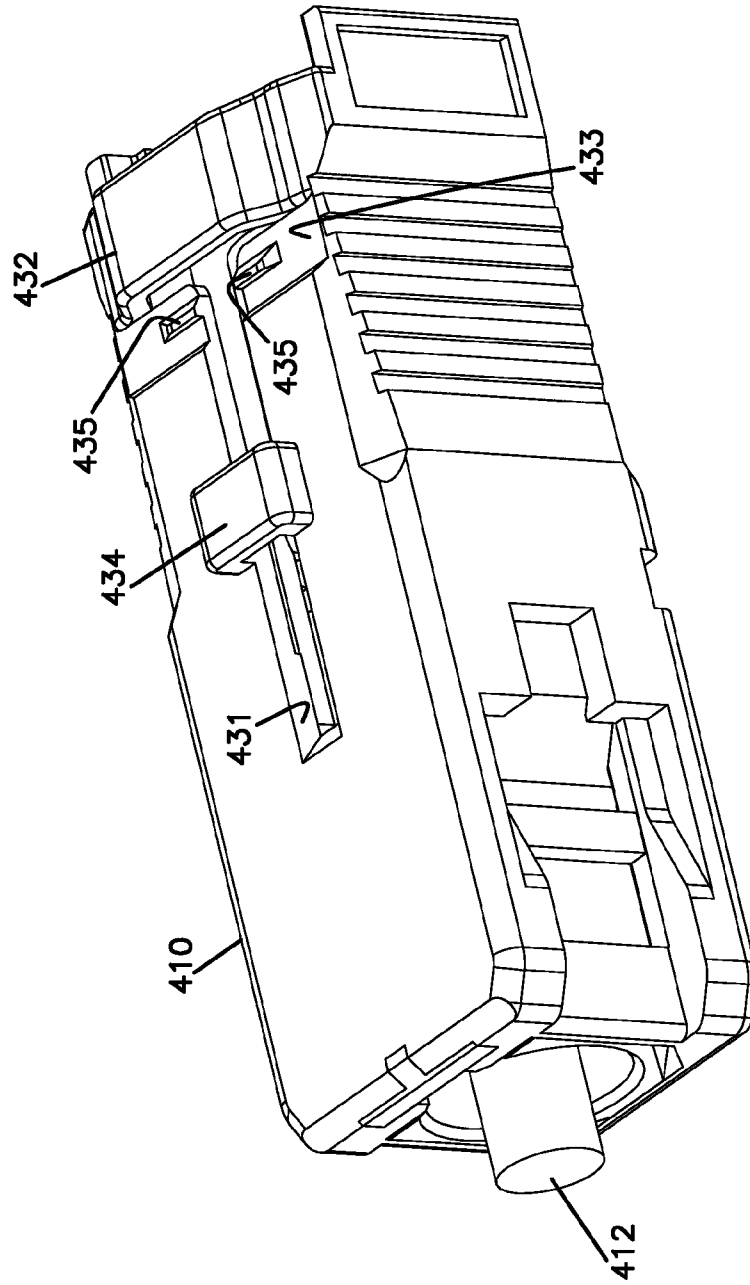
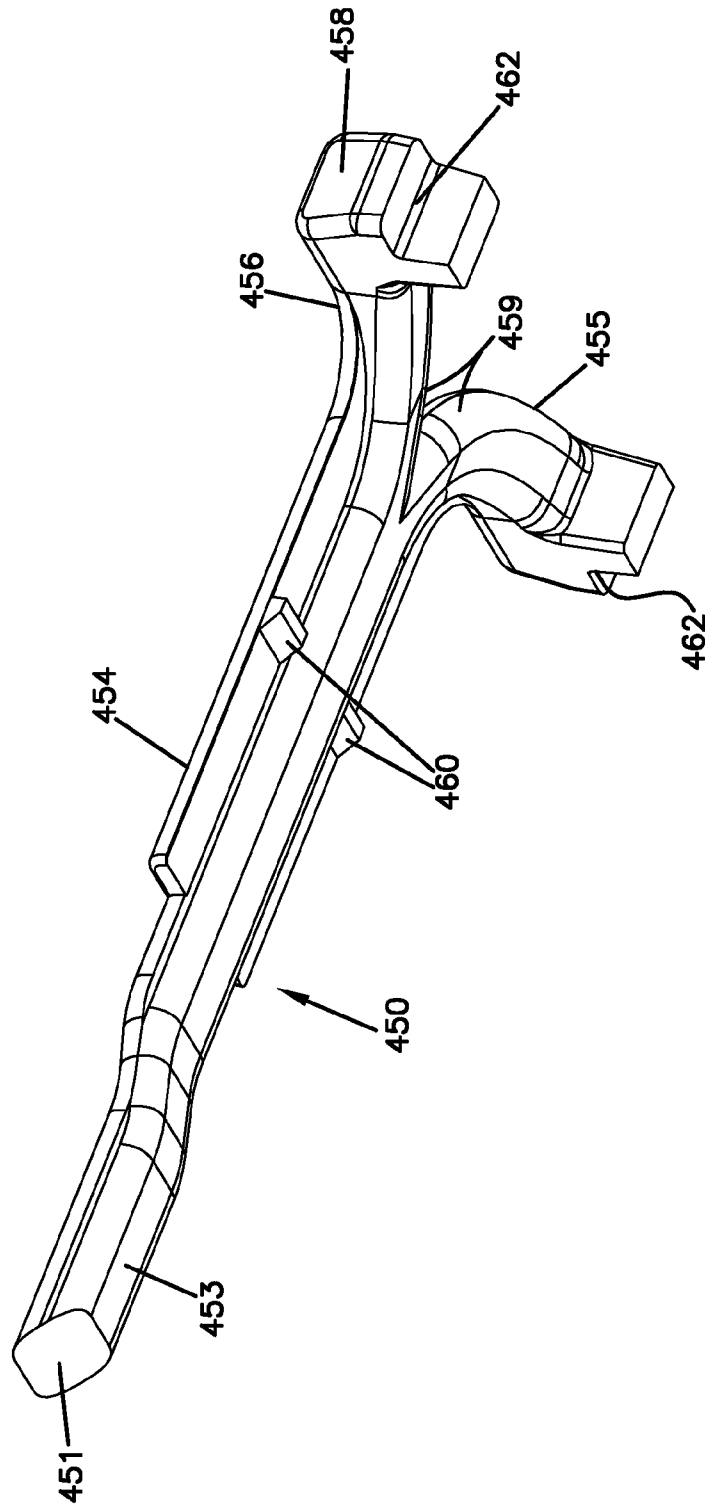

FIG. 13



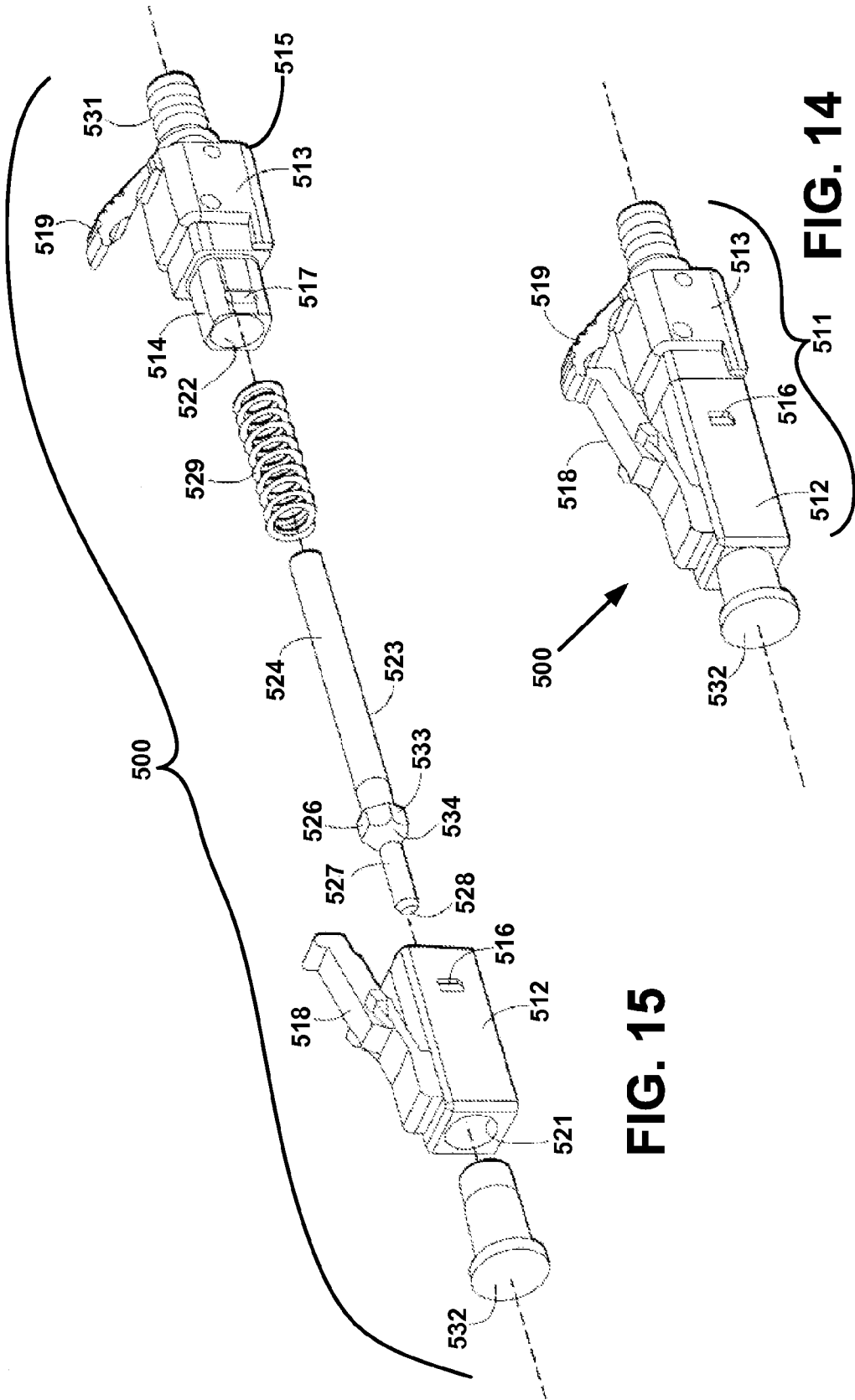
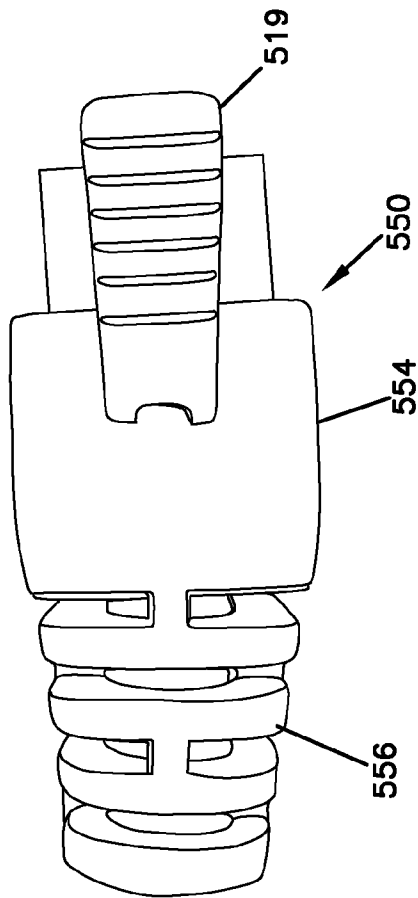

FIG. 15

FIG. 14

**FIG. 16**



**FIG. 17**

