

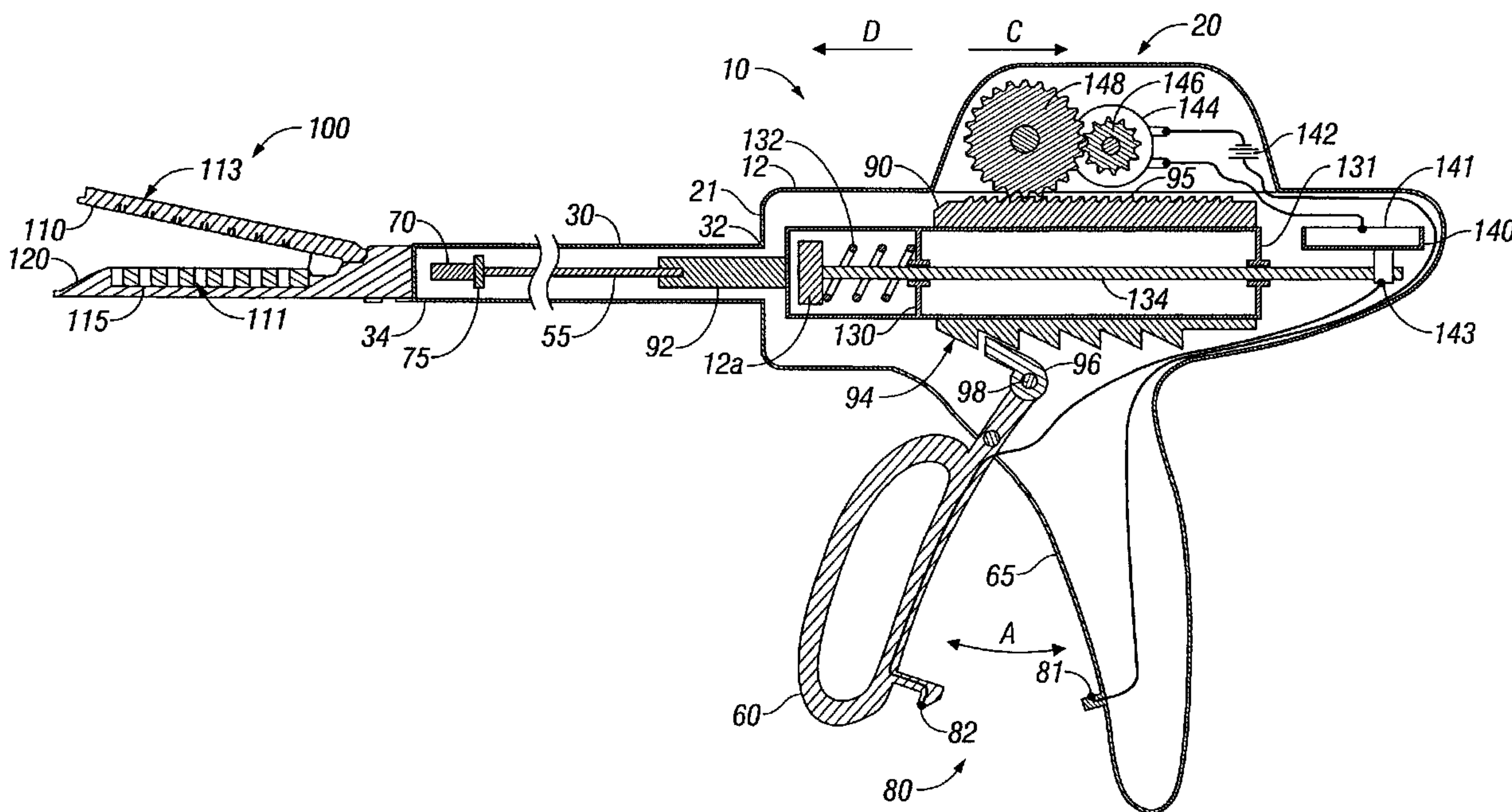

(22) **Date de dépôt/Filing Date:** 2008/02/14
 (41) **Mise à la disp. pub./Open to Public Insp.:** 2008/09/15
 (45) **Date de délivrance/Issue Date:** 2015/06/16
 (30) **Priorité/Priority:** 2007/03/15 (US11/724,744)

(51) **Cl.Int./Int.Cl. A61B 17/068** (2006.01),
A61B 17/072 (2006.01)
 (72) **Inventeur/Inventor:**
MARCZYK, STANISLAW, US
 (73) **Propriétaire/Owner:**
TYCO HEALTHCARE GROUP LP, US
 (74) **Agent:** OSLER, HOSKIN & HARCOURT LLP

(54) **Titre : AGRAFEUSE CHIRURGICALE MOTORISEE**
 (54) **Title: POWERED SURGICAL STAPLING DEVICE**



(57) **Abrégé/Abstract:**

A surgical stapler which includes a tool assembly having a pair of opposing tissue engaging surfaces for deforming a plurality of surgical fasteners through and fastening tissue is disclosed. The surgical stapler includes a housing having a fixed handle and a movable handle mounted to said housing and selectively movable relative to said fixed handle from a first position to a second position to actuate the clamping of tissue. The stapler further includes a drive assembly including a motor, a power source and a coupling member. The motor engages the coupling member, wherein movement of the movable handle to the second position activates the motor, which advances a firing shaft and forces a firing piston into said tool assembly to deform the surgical fasteners through and fasten tissue.

5

ABSTRACT

A surgical stapler which includes a tool assembly having a pair of opposing tissue engaging surfaces for deforming a plurality of surgical fasteners through and fastening tissue is disclosed. The surgical stapler includes a housing having a fixed handle and a movable handle mounted to said housing and selectively movable relative to said fixed handle from a first position to a second position to actuate the clamping of tissue. The stapler further includes a drive assembly including a motor, a power source and a coupling member. The motor engages the coupling member, wherein movement of the movable handle to the second position activates the motor, which advances a firing shaft and forces a firing piston into said tool assembly to deform the surgical fasteners through and fasten tissue.

5

POWERED SURGICAL STAPLING DEVICE

BACKGROUND

10

Technical Field

The present disclosure relates to a surgical stapler for implanting
15 mechanical surgical fasteners into the tissue of a patient, and, in particular, to a surgical
stapler which is powered by a motor for firing surgical fasteners into tissue.

Background of Related Art

20 Current known devices can typically require 10-60 pounds of manual hand
force to clamp tissue and deploy and form surgical fasteners in tissue which, over
repeated use, can cause a surgeon's hand to become fatigued.

Gas powered pneumatic staplers which implant surgical fasteners into
25 tissue are known in the art. Certain of these instruments utilize a pressurized gas
supply which connects to a trigger mechanism by way of an intricate series of hoses
and actuators. The trigger mechanism, when depressed, simply releases pressurized
gas to implant a fastener into tissue.

30 Motor-powered surgical staplers are also known and are disclosed in U.S.
Patent No. 5,383,880 to Hooven and U.S. Patent No. 6,716,233 to Whitman. The '880
and the '233 patents disclose powered surgical staplers including motors which activate

5 staple firing mechanisms. In particular, the '880 patent discloses a powered stapler
wherein the power of the motor is automatically controlled based on various types of
sensor data (e.g., tissue thickness). The '233 patent teaches a powered stapler that is
automatically controlled as a function of sensor data. However, both of these
references only provide for limited user control of the stapling process. The '880 and
10 '233 patents provide the user with the option of toggling a single switch and/or button to
actuate the powered stapler which then automatically controls the motor and applies
corresponding torque to the stapler's firing mechanisms. Consequently, in these
references, the user only controls activation and deactivation of the device and the
device does not provide any tactile feedback.

15

It would be desirable to provide a low cost motor powered stapler that
provides the needed energy required to fire the instrument to form a series of surgical
fasteners into and through tissue. It would also be desirable to provide an
ergonomically advanced surgical stapler which reduces fatigue during repeated use and
20 provides the surgeon with more tactile feedback during activation of the stapler. It
would further be desirable to provide a powered stapler which provides the user with
tactile feedback allowing to user to vary the force applied by the motor on the stapling
and/or clamping mechanisms.

25

5 SUMMARY

According to one aspect of the present disclosure, a surgical stapler having a tool assembly at its distal end is disclosed. The tool assembly includes a pair of opposing tissue engaging surfaces for deforming a plurality of surgical fasteners through and fastening tissue. The stapler also includes a housing having a fixed handle and a movable handle mounted to said housing and selectively movable relative to said fixed handle from a first position in spaced relation relative to said fixed handle to a second position closer to said fixed handle to actuate the clamping of tissue. The stapler further includes a drive assembly having a power source and a motor which engages a coupling member, the coupling member is operatively coupled to the movable handle, wherein movement of the movable handle to the second position activates the motor, which advances the coupling member which in turn advances a firing shaft and forces a firing piston into said tool assembly to deform the surgical fasteners through and fasten tissue, such that the rate at which the motor advances the coupling member is variably controlled in response to the force exerted on the movable handle during movement thereof to the second position.

According to another aspect of the present disclosure a surgical stapler is provided. The surgical stapler includes a housing, an elongated member attached to the housing, and a tool assembly attachable to the distal end of the elongated member, said tool assembly including an anvil assembly and a cartridge assembly each having an opposing tissue engaging surface, said cartridge assembly including a plurality of

5 surgical fasteners. The stapler also includes a selectively activateable drive assembly including a power source and a motor which engages a coupling member, the coupling member is operatively coupled to the movable handle, wherein upon actuation the motor advances the coupling member which advances a firing shaft and forces a firing piston into said tool assembly to deform the surgical fasteners through and fasten
10 tissue, such that the rate at which the motor advances the coupling member is variably controlled in response to the force exerted on the movable handle.

BRIEF DESCRIPTION OF THE DRAWINGS

15 Various embodiments of the subject instrument are described herein with reference to the drawings wherein:

FIG. 1 is a schematic, side view with portions broken away of a surgical
20 stapler according to the present disclosure having a motor-powered drive assembly for forming fasteners;

FIG. 2 is a schematic, side view with portions broken away of an alternate
embodiment of a tool assembly for use with the stapler of FIG. 1; and

25 FIG. 3 is a schematic, side view with portions broken away of a surgical stapler according to an embodiment of the present disclosure; and

FIG. 4 is a schematic, side view with portions broken away of a surgical
30 stapler according to another embodiment of the present disclosure.

5 DETAILED DESCRIPTION

Referring initially to the embodiment disclosed in FIGS. 1 and 2, a surgical stapler 10 is shown having a motor-powered drive assembly here shown as including a drive assembly 20. It is envisioned that the presently disclosed drive assembly 20 can be utilized with any type of known surgical stapler. As such, a general surgical stapler 10 is schematically depicted in the drawings and described herein. For example, stapler 10 includes a housing 12 having an elongated member or shaft 30 attached thereto. Shaft 30 includes a proximal end 32 which attaches to a distal end 21 of the housing 12 and a distal end 34 which operatively couples to a tool assembly such as an end effector 100 or a tool assembly 200. The end effector 100 depicted in FIG. 1 is a conventional longitudinal stapler having opposing tissue contacting surfaces 110 and 120. The contact surface 110 acts as an anvil assembly 113 and the contact surface 120 includes a cartridge assembly 111 having a plurality of surgical fasteners 115. During operation, as the contact surfaces 110 and 120 are closed about tissue, the surgical fasteners 115 are fired from the cartridge assembly 111, through tissue, and the surgical fasteners are deformed by the anvil assembly of the contact surface 110 as discussed in more detail below.

The tool assembly 200 depicted in FIG. 2 is that of a conventional circular stapler (not shown) having opposing tissue contacting surfaces 210 and 220, wherein the contacting surface 210 is formed on the anvil assembly and the contact surface 220

5 is formed on the cartridge assembly. For the purposes herein, stapler 10 will be described as having tool assembly 100 attached to distal end 34 of an elongate shaft.

Housing 12 includes a fixed handle 65 which is generally in the form of a pistol grip to enhance manipulation of the stapler 10 as needed during surgery. Stapler
10 10 also includes a movable handle 60 which is movable relative to fixed handle 65 (in the direction "A") to actuate opposing tissue contacting surfaces 110 and 120 of tool assembly 100 to manipulate, grasp fasten and cut tissue. The proximal end of shaft 30 is integrally associated with, mounted to, or selectively attachable to housing 12. One or more actuating assemblies are incorporated within housing 12 and may include
15 manual, robotic or computer operated systems. The actuating assembly may comprise that of a known open or endoscopic surgical stapler. Many types of mechanical actuators and handle mechanisms are known which are configurable to communicate with and actuate the functions of tool assembly 100. Mechanical actuators and handle mechanisms are disclosed in U.S. Patents Nos. 5,318,221, 5,762,256 and 5,865,361.

20

As best seen in FIG. 1, a staple deformation or staple firing mechanism 70 (e.g., firing piston) and knife assembly 75 may also be included in distal end 34 of the shaft 30 and/or included with tool assembly 100. It is contemplated that the same or
25 separate actuating mechanisms may be employed to drive staple firing mechanism 70 and knife assembly 75. The movable handle 60 cooperates with tool assembly 100 to grasp tissue, as is known in the art. The movable handle 60 also actuates the drive

5 assembly 20 which drives the staple firing mechanism 70 and/or the knife assembly 75 through tissue. The staple firing mechanism 70 may be configured as a longitudinally movable member or beam that pushes an actuation sled through cartridge assembly 111 to deploy staples against the anvil assembly 110, as is known in the art. Such a mechanism is disclosed in U.S. Patent Application Publication No. 2004/0232201.

10

FIG. 1 shows one embodiment of a stapler 10 which includes the drive assembly 20 housed within surgical stapler 10 to actuate a firing shaft 55 which, in turn, cooperates with tool assembly 100 to clamp tissue between tissue engaging surfaces 15 110 and 120 and to drive a plurality of surgical fasteners 115. For example, as disclosed in U.S. Patent Publication No. 2004/0232201, the drive beam may include a member, such as a cam roller, for engaging a cam surface of the anvil assembly to approximate the cartridge assembly and anvil assembly and to clamp tissue therebetween. The same drive beam may also be used to deploy the staples from the 20 cartridge assembly. The disclosure of U.S. Patent Application Publication No. 2004/0232201. Surgical stapler 10 is preferably, as shown, designed for one-handed operation by the user and requires minimal pulling force of the movable handle 60 to deform the surgical fasteners 115 through tissue. In other words, stapler 10 is designed such that drive assembly 20 25 actuates and controls the high-force portion of the activation sequence (i.e., the so-called "firing stroke") thus alleviating user fatigue and allowing simple, consistent and repeated use of the stapler during surgery.

5

The drive assembly 20 includes a coupling member 90 operatively coupled to a shaft connector 92 which is coupled to the firing shaft 55, such that longitudinal movement of the coupling member 90 in the direction "D" is translated to the firing shaft 55. The coupling member 90 includes a ratchet track 94 having one or more teeth interfacing with a pawl 96 allowing for unidirectional motion. The pawl 96 is rotatively coupled to the movable handle 60 via a pin 98, such that when the movable handle 60 is pulled toward the handle 65, the pawl 98 engages one of the teeth of the ratchet track 94 and pushes the coupling member 90 in the distal direction "D." The staple firing mechanism 70 is advanced by the distal movement of the coupling member 90 and firing shaft 55. The staple firing mechanism 70 engages the anvil assembly 113 and cartridge assembly 111 to clamp tissue therebetween. Further actuation of the staple firing mechanism deploys staples from the staple cartridge assembly 111 and deforms the staples against the anvil assembly 113.

The coupling member 90 includes a lumen defined therein having supporting walls 130 and 131. The supporting wall 130 along with the shaft connector 92 encloses a spring 32 or another compression mechanism. The spring 32 applies pressure onto supporting wall 130 which in turn pushes the coupling member 90 in the proximal direction "C." The pressure on the coupling member 90 also moves apart the movable handle 60 away from the fixed handle 65, keeping the movable handle 60 in an unactuated position (e.g., first position).

5 The drive assembly 20 includes an electric DC motor 144 connected to a power
source 142 (e.g., a battery). A variable resistor 140 and a switch 80 are connected in
series with the DC motor 144 and the power source 142. The switch 80 is open when
the movable handle 60 is in the first position and is closed when then movable handle
60 is pulled in the proximal direction into the second position actuating the coupling
10 member 90. In particular, a contact 82 disposed on the movable handle 60 contacts a
contact 81 disposed on the fixed handle 65. Once the contacts 81 and 82 are touching,
the switch 80 is closed and the DC motor 144 is activated. It is envisioned that the
switch 80 may be implemented via a variety of embodiments known to those skilled in
the art, such as a push button switch being disposed on the fixed handle 65 and being
15 activated by physical contact of the movable handle 60 as the movable handle 60 is
actuated. As discussed above, the spring 132 biases the movable handle 60 away from
the fixed handle 65 to maintain the switch 80 in an open position thereby preventing
inadvertent activation of the DC motor 144. More specifically, the spring 132 biases the
coupling member 90 by acting on a housing potion 12a and supporting wall 130.

20

 The DC motor 144 is coupled to a unidirectional clutch 146 which
interfaces with a pinion gear 148. Once the DC motor 144 is activated by pulling of the
movable handle 60, the clutch 146 rotates in a clockwise direction rotating the gear 148
in the clockwise direction as well. The gear 148 interfaces with a rack surface 95 of the
25 coupling member 90 and the rotational motion of the gear 148 translates the coupling
member 90 in a longitudinal motion, advancing the coupling member 90 and the firing
rod 55 in a distal direction "D."

5

The rate at which the DC motor 144 rotates, and hence, the rate at which the firing shaft 55 is moved in the distal direction, is controlled via the variable resistor 140. In FIG. 1 the variable resistor 140 is shown as a potentiometer 141 with a contact 143 (e.g., wiper terminal) disposed in contact therewith. The contact 143 is coupled to the shaft connector 92 via a shaft 134. The contact 143 slides along the surface of the potentiometer 141 as the coupling member 90 is moved in the distal direction by pulling of the movable handle 60. As the contact 143 slides across the potentiometer 141 the voltage supplied to the DC motor 144 varies accordingly. In particular, varying the position of the contact 143 along the potentiometer 141 adjusts the rate of rotation of the DC motor 144. The distance the contact 143 moves along the potentiometer 141 is proportional to the force exerted by the user in pulling the movable handle 60. As the movable handle 60 is moved, contact 143 moves a distance, and the pulling force on the movable handle 60 is counterbalanced by the force of the spring 132 on the movable handle 60. The further the contact 142 moves under the pulling action on the movable handle 60, the more compression force is applied by the spring 132. Consequently, the rate of rotation of the DC motor 144 and the force with which the firing shaft 55 is moved distally is proportional to the pulling force. Namely, when resistance in potentiometer 141 is low, the torque from the DC motor 144 is high and when the resistance in potentiometer 141 is high, the torque from the DM motor 144 is low.

20

25

The switch 80 is arranged to allow clamping of tissue before the motor 144 is actuated. This provides for user control of the initial grasping of the tissue with the end

5 effector 100 and subsequent power-assisted firing of surgical fasteners 115. Those skilled in the art will appreciate that the disclosed variable resistor 140 may also be a rheostat.

Use of the surgical stapler 10 is as follows. The surgical stapler is
10 positioned with the end effector 100 at the surgical site and the tissue engaging surfaces 110 and 120 are placed around tissue. The user thereafter initiates the stapling process by pulling on the movable handle 60 to bring the movable handle 60 toward the fixed handle 65 and clamp tissue. With further movement of movable handle 60, the switch 80 is closed. Simultaneously, the movable handle 60 moves the coupling
15 member 90 in the distal direction along the direction "C" thereby moving the contact 143 along the potentiometer 141. The clamping force exerted by the pulling of the movable handle 60 is counterbalanced by the tissue being grasped and the spring 132. As the movable handle 60 moves the coupling member 90, the contact 143 moves along the potentiometer 141, adjusting the voltage supplied to the DC motor 144. The DC motor
20 144 rotates at the rate corresponding to the supplied voltage as varied by the variable resistor 140. In response thereto, the DC motor 144 actuates the pinion gear 148 via the unidirectional clutch 146. The rotational motion of the pinion gear 148, which interfaces with the rack surface 95, is translated into longitudinal motion of the coupling member 90 and the firing shaft 55. The firing shaft 55 forces the staple firing
25 mechanism 70 and knife assembly 75 through tissue to sequentially fasten and separate the tissue. Consequently, the rates at which the opposing tissue contacting surfaces 110 and 120 are closed and the staples are fired are directly proportional to

5 the pulling force on the movable handle 60. This provides the user with tactile feedback during the stapling process. Those skilled in the art will appreciate that a series of gears, shafts, screws or other mechanisms may be employed to convert the rotational energy of the drive assembly 20 to firing shaft 55 to actuate tool assembly 100. The drive assembly 20 desirably includes a switch for reversing the motor 144 for retracting
10 the staple firing mechanism 70, and releasing the end effector 100 from tissue. A button may be provided on the housing 12 to actuate the switch.

Fig. 3 shows another embodiment of the surgical stapler 10 which utilizes the potentiometer 141 as a switch to activate the drive assembly 20. In this
15 embodiment, switch 80 and hence contacts 81, 82 are not used. When the movable handle 60 is in the open position away from the fixed handle 65, the potentiometer 141 does not electrically contact the contact 143. When the movable handle 60 is brought toward the fixed handle 65 to clamp tissue, the potentiometer 141 is brought into contact with the contact 143 and the drive assembly 20 is activated. The drive
20 assembly 20 is controlled by varying the voltage as the potentiometer 141 is sliding across the contact 143, which corresponds to the clamp force being applied to the movable handle 60.

Fig. 4 shows a further embodiment of the surgical stapler 10 having a
25 switch assembly 200. The switch assembly 200 is used in place of the potentiometer 141, contact 143 and the switch 80. The switch assembly 200 includes a handle 201 which is pivotally coupled to the fixed handle 65. The handle 201 is biased by a spring

5 203 against the fixed handle 65. The switch assembly 200 also includes a pressure
sensor 202 disposed between the fixed handle 65 and the handle 201. The pressure
sensor 201 may be a piezoelectric sensor configured to sense pressure applied by the
handle 201. During clamping, as the movable handle 60 is pulled toward the fixed
handle 65, the handle 201 is pushed toward the fixed handle 65. The pressure sensor
10 202 records pressure applied on the handle 201 as sensor signals, which are
representative of the clamping force, and transmits the signals to a motor controller 204.
The motor controller 204 thereafter controls the drive assembly 20 based on the sensor
signals. The rates at which the opposing tissue contacting surfaces 110 and 120 are
closed and the staples are fired are directly proportional to the pushing force on the
15 handle 201.

Preferably, the presently disclosed staplers are designed for endoscopic
use and are dimensioned to fit through a trocar or cannula for various endoscopic and
laparoscopic procedures. As can be appreciated, the overall dimensions of the tool
20 assembly and the elongated shaft are sized accordingly to fit through the trocar or
cannula. Alternatively, the presently disclosed staplers may also be designed and/or
used for open surgical procedures. The disclosed surgical staplers preferably are
suitable for one-handed operation by the user.

25 The surgical stapler of Fig. 1 has a staple firing mechanism 70 that
deploys staples from the staple cartridge assembly, as well as engages the cartridge
assembly and anvil assembly to clamp tissue therebetween. It is contemplated that

5 separate clamping and firing mechanisms may be used. By way of example, the anvil
assembly and cartridge assembly may be approximated using a tube that is separate
from the staple firing mechanism, as disclosed in U.S. Patent No. 5,318,221.

10 It will be understood that various modifications may be made to the
embodiments shown herein. Therefore, the above description should not be construed
as limiting, but merely as exemplifications of preferred embodiments. The scope of the
claims should not be limited by the preferred embodiments set forth herein, but should be
given the broadest interpretation consistent with the description as a whole.

15

The embodiments of the present invention for which an exclusive property or privilege is claimed are defined as follows:

1. A surgical stapler including a tool assembly having a pair of opposing tissue engaging surfaces for deforming a plurality of surgical fasteners, the tool assembly being attached at a distal end of the surgical stapler, the surgical stapler comprising:

a housing having a fixed handle;

a movable handle mounted to the housing and selectively movable relative to the fixed handle along a trajectory from a first position in spaced relation relative to the fixed handle to a second position closer to the fixed handle;

a coupling member in mechanical cooperation with the movable handle such that movement of the movable handle to the second position along the trajectory advances the coupling member to clamp tissue; and

a drive assembly including a power source and a motor which engages the coupling member, the motor being arranged with the coupling member so that activation of the motor advances the coupling member which in turn advances a firing shaft to deploy and deform the surgical fasteners, the drive assembly including a controller, such that the rate at which the motor advances the coupling member is variably controlled in response to the force exerted on the movable handle;

wherein movement of the movable handle to a third position along the trajectory activates the motor such that the coupling member may be advanced initially with the motor in an inactivated condition and subsequently with the motor in an actuated condition by a single movement of the movable handle from the first position to the second position along the trajectory.

2. The surgical stapler according to claim 1, wherein the coupling member advances the firing shaft to actuate the tool assembly to initially clamp tissue between opposing tissue engaging surfaces of the tool assembly.
3. The surgical stapler according to claim 1, wherein the drive assembly includes a variable resistor coupled in series with the motor and the power source.
4. The surgical stapler according to claim 3, wherein the variable resistor regulates an amount of voltage supplied to the motor as a function of the force exerted on the movable handle during movement thereof to the second position.
5. The surgical stapler according to claim 4, wherein the drive assembly further includes a spring which compresses the coupling member to maintain the movable handle in the first position.
6. The surgical stapler according to claim 3, wherein the variable resistor is selected from the group consisting of a potentiometer and a rheostat.
7. The surgical stapler according to claim 1, wherein the drive assembly includes a switch coupled in series with the motor and the power source, wherein the switch is closed by moving the movable handle to the second position.

8. A surgical stapler, comprising:

a housing;

an elongated member attached to the housing;

a tool assembly attachable to a distal end of the elongated member, the tool assembly including an anvil assembly and a cartridge assembly each having an opposing tissue engaging surface, the cartridge assembly including a plurality of surgical fasteners;

a movable handle mounted to the housing and selectively movable relative to the housing along a trajectory from a first position in spaced relation relative to the housing to a second position closer to the housing to approximate the opposing tissue engaging surfaces;

a selectively activateable drive assembly including a power source and a motor which engages a coupling member, wherein upon actuation the motor advances the coupling member which advances a firing shaft to deploy and deform the surgical fasteners, the selectively activateable drive assembly also including a controller configured to variably control the rate at which the motor advances the coupling member in response to the force exerted on the movable handle;

wherein movement of the movable handle to a third position along the trajectory activates the motor such that the opposing tissue engaging surfaces may be approximated initially with the motor in an inactivated condition and the surgical fasteners may be deployed and deformed subsequently with the motor in an actuated condition by a single movement of the movable handle from the first position to the second position along the trajectory.

9. The surgical stapler according to claim 8, wherein the coupling member advances the firing shaft to actuate the tool assembly to initially clamp tissue between opposing tissue engaging surfaces of the tool assembly.
10. The surgical stapler according to claim 8, wherein the drive assembly includes a variable resistor coupled in series with the motor and the power source.
11. The surgical stapler according to claim 10, wherein the variable resistor regulates amount of voltage supplied to the motor as a function of the force exerted on the movable handle during movement thereof to the second position.
12. The surgical stapler according to claim 11, wherein the drive assembly further includes a spring which compresses the coupling member to allow for selective actuation of the drive assembly upon application of sufficient force.
13. The surgical stapler according to claim 11, wherein the variable resistor is selected from the group consisting of a potentiometer and a rheostat.
14. The surgical stapler according to claim 8, wherein the drive assembly includes a switch coupled in series with the motor and the power source, wherein the switch is closed by moving the movable handle to the second position.

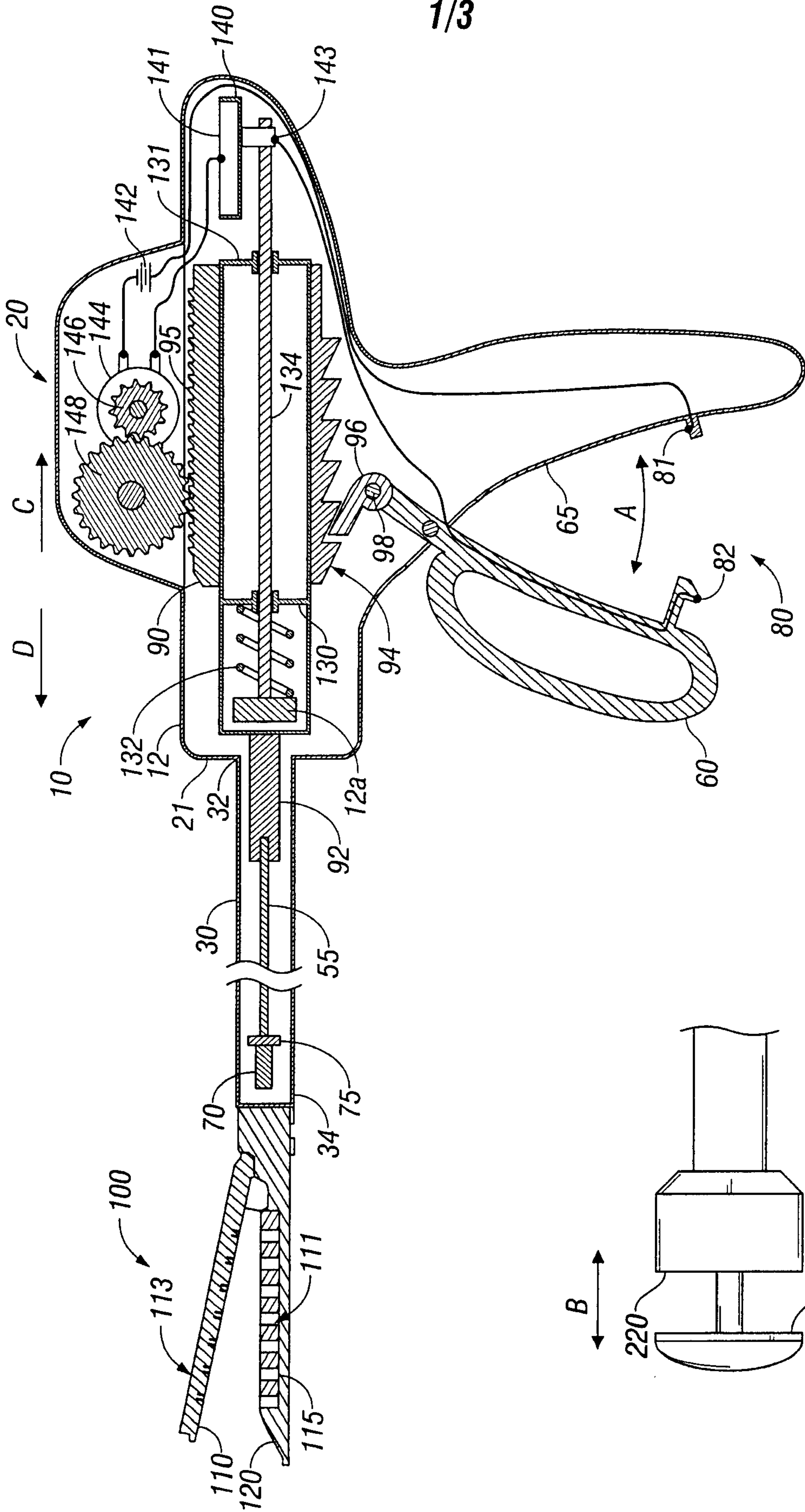

FIG. 1

FIG. 2

