

(19) World Intellectual Property Organization
International Bureau



(43) International Publication Date
24 October 2002 (24.10.2002)

PCT

(10) International Publication Number
WO 02/083988 A2

(51) International Patent Classification⁷: **C25B 9/00**,
3/00, 3/12, B01J 19/00

(21) International Application Number: PCT/GB02/01608

(22) International Filing Date: 5 April 2002 (05.04.2002)

(25) Filing Language: English

(26) Publication Language: English

(30) Priority Data:
0109239.4 12 April 2001 (12.04.2001) GB
0126182.5 31 October 2001 (31.10.2001) GB

(71) Applicant (for all designated States except US): **ASTRA
ZENECA AB** [SE/SE]; 5-151 85, Söderstälje (SE).

(72) Inventors; and

(75) Inventors/Applicants (for US only): **SHAW, John,
Edward, Andrew** [GB/GB]; 45 Colne Avenue, West
Drayton, Middlesex UB7 7AL (GB). **SHUTE, Richard,
E.** [GB/GB]; 210 Prestbury Road, Macclesfield (GB).

(74) Agent: **LAURENCE SHAW & ASSOCIATES**;
Metropolitan House, 1 Hagley Road, Edgbaston, Birming-
ham B16 8TG (GB).

(81) Designated States (national): AE, AG, AL, AM, AT, AU,
AZ, BA, BB, BG, BR, BY, BZ, CA, CH, CN, CO, CR, CU,
CZ, DE, DK, DM, DZ, EC, EE, ES, FI, GB, GD, GE, GH,
GM, HR, HU, ID, IL, IN, IS, JP, KE, KG, KP, KR, KZ, LC,
LK, LR, LS, LT, LU, LV, MA, MD, MG, MK, MN, MW,
MX, MZ, NO, NZ, OM, PH, PL, PT, RO, RU, SD, SE, SG,
SI, SK, SL, TJ, TM, TN, TR, TT, TZ, UA, UG, US, UZ,
VN, YU, ZA, ZM, ZW.

(84) Designated States (regional): ARIPO patent (GH, GM,
KE, LS, MW, MZ, SD, SL, SZ, TZ, UG, ZM, ZW),
Eurasian patent (AM, AZ, BY, KG, KZ, MD, RU, TJ, TM),
European patent (AT, BE, CH, CY, DE, DK, ES, FI, FR,
GB, GR, IE, IT, LU, MC, NL, PT, SE, TR), OAPI patent
(BF, BJ, CF, CG, CI, CM, GA, GN, GQ, GW, ML, MR,
NE, SN, TD, TG).

Published:

— without international search report and to be republished
upon receipt of that report

For two-letter codes and other abbreviations, refer to the "Guid-
ance Notes on Codes and Abbreviations" appearing at the begin-
ning of each regular issue of the PCT Gazette.



WO 02/083988 A2

(54) Title: MICRO-ENGINEERED REACTORS

(57) Abstract: The invention relates to a micro-engineered reactor device comprising a closely coupled reactor and electrochemical cell, and a method of using such a reactor for the synthesis of organic compounds by a process involving an electrochemical reaction. The synthetic processes are of a type in which a source material is electrochemically converted to a reactive primary product which is exposed at a reaction region within a channel, or chamber, to a precursor material so that the primary product and precursor material react to generate a secondary product.

MICRO-ENGINEERED REACTORS

The invention relates to micro-engineered reactors for use in the synthesis of organic compounds by a process involving an electrochemical reaction, and to methods of using such micro-engineered reactors. The synthetic processes are of a type in which a source material is electrochemically converted to a reactive primary product which is exposed at a reaction region within a channel, or chamber, to a precursor material so that the primary product and precursor material react to generate a secondary product.

Electrochemical reactions are relatively little used in organic synthesis. This is due to a variety of limitations, which include the identification of few clean and direct electrochemical conversions of organic species, limitation to polar ionically conductive media which are incompatible with many organo-synthetic processes, and relatively low ionic conductivity of organic solutions, which can limit current and throughput. It is possible to increase current by increasing applied potentials but this tends to increase heating of the ionically conducting fluid body and introduce difficulties in achieving controlled potentials at the electrodes and clean electrochemical processes.

There are however, many widely used synthetic reactions, which utilise reactive high-energy reactants. Examples of such reactants are organometallic materials such as lithium or sodium alkyls, and Grignard reagents. Long term storage of such materials can be impractical or hazardous and they are often synthesised shortly before use from precursor reagents and active metals. The active metals, used in the synthesis of the organometallics, especially the alkali metals, may themselves be hazardous or difficult to handle, and may on storage accumulate corrosion products that interfere with their use in organic syntheses. The active metals are normally supplied by the producers as sheet, rod, or granules which may have to be cut or otherwise mechanically processed in dry oxygen free or otherwise protected environments before being employed in organic synthesis to produce sufficient clean active surface area. The handling and processing of these active metals can be hazardous and adds to process complexity and to the cost of generating the desired organometallic reagents. Active metals for use in the synthesis of organometallic species according to conventional procedures can be or are generated electrochemically. It is an advantage of the proposed devices that such material is generated in situ as a primary product for reaction with a precursor reagent. The proposed devices allow the controlled generation of active metals and their derivatives in enclosed structures minimising hazards associated with handling excess material and exposure to contaminants.

Micro-fabrication techniques are known in the semiconductor industry for the manufacture of integrated circuits and the miniaturisation of electronics. It is also possible to fabricate intricate fluid flow systems with channel sizes as small as a micron (10^{-6} metre). These devices can be mass-produced inexpensively and are expected to soon be in widespread use for simple analytical tests. See, e.g., Ramsey, J.M. et al. (1995), "Microfabricated chemical measurement Systems," *Nature Medicine* 1:1093-1096; and Harrison, D.J. et al. (1993) "Micro-machining a miniaturised capillary electrophoresis-based chemical analysis system on a chip," *Science* 261:895-897. Miniaturisation of laboratory techniques is not a simple matter of reducing their size. At small scales different effects become important, rendering some processes inefficient and others useless. It is difficult to replicate smaller versions of some devices because of material or process limitations. For these reasons it is necessary to develop new methods for performing common laboratory tasks on the micro-scale.

Devices made by micro-machining planar substrates have been made and used for chemical separation, analysis, and sensing. See, e.g., Manz, A. et al. (1994), "Electro-osmotic pumping and electrophoretic separations for miniaturised chemical analysis system," *Micromech. Microeng.* 4:257-265. In addition devices have been proposed for preparative analytical and diagnostic methods which bring two streams of fluid in laminar flow together which allows molecules to diffuse from one stream to the next, examples are proposed in WO9612541, WO9700442 and US5716852.

In this disclosure, the terms "microfabricated" and "micro-engineered" includes devices capable of being fabricated on plastic, glass, silicon wafers or any other material readily available to those practising the art of microfabrication, such as photolithography, screen printing, wet or dry isotropic and anisotropic etching processes, reactive ion etching (RIE), laser assisted chemical etching (LACE), laser and mechanical cutting of metal, ceramic, and plastic substrates, plastic laminate technology, LIGA, thermoplastic micropattern transfer resin based microcasting, micromolding in capillaries (MIMIC), and, or other techniques known within the art of microfabrication. As in the case of silicon microfabrication, large wafers can be used to accommodate a plurality of the devices of this invention in a plurality of configurations. A few standard wafer sizes are 3" (7.5 cm), 4" (10 cm), 6" (15 cm), and 8" (20 cm). Application of the principles presented herein using new and emerging microfabrication methods is within the scope and intent of the present invention. Microfabricated devices may be created through combinations of manufacturing processes such as: (1) photolithography, the optical process of creating microscopic patterns (2) etching, the process that removes substrate material and (3) deposition, the process whereby materials with a specific function can be coated onto a surface of the substrate.

Connections with liquid reservoirs external to the device may be made by a variety of means including adhesive bonding to fine tubes and capillaries, anodic or other bonding to manifold structures linked to macroscopic unions, or methods in accordance with Mourlas N.J. et al. Proceedings of the μ TAS'98 Workshop, Kluwer Academic Publishers 27-, and references cited therein.

An object of the present invention is to provide a micro-engineered reactor, and method of using such a micro-engineered reactor, suitable for the synthesis of organic compounds involving reaction with a material produced in situ by electrochemical means that overcomes at least some of the problems encountered in the past, and exploits the advantages of micro-engineered flow passages.

By employing reactors of micro-engineered dimensions, it is possible to achieve short ionically conductive pathways limiting resistive voltage drops and heating. The short distance across fluids to surfaces that can be cooled avoids excessive temperature rises, either from ohmic (Joule) heating or from reactions of high-energy products. Flowing reagents through relatively narrow channels or chambers allows rapid diffusive transfer of reagents to surfaces so that precursor reagents can be efficiently and rapidly presented to the primary electrochemical products, such as reactive metal layers. Generating the active primary product and subsequent products in the reactor device as required, avoids the accumulation of hazardous inventory and the device provides a level of confinement and avoids dangers inherent in handling of the materials.

By using micro-engineering techniques, the depths of features are generally defined by etching or deposition of material and it is possible to form conduits or flow channels with depth dimensions down to $\sim 1\mu\text{m}$. In general in the present invention, the term "micro-engineered" refers to channels with depths of 0.1 to 1000 μm . Although channel depths up to 1000 μm allow significantly greater throughputs, and lower flow resistance, the preferred range of sizes are between 1 to 500 μm and especially 30 to 300 μm . Channel widths and lengths are generally defined by lithographic techniques, and may range from a few micrometers to centimetre dimensions. By using combinations of such conduits or flow channels, transit and mixing times of the order of seconds down to milliseconds in liquids, and microseconds in gases may be achieved.

The use of electricity to drive redox reactions is also well understood and is applied in electrolytic extraction of aluminium metal from ore using molten electrolyte, electroplating and rechargeable batteries. An electrochemical redox process is one in which one or more

electrons is transferred between an electrode and a chemical species in an electrochemical cell. Chemical species which are able to gain or loses electrons in this way are redox active species. Such species may be transformed to other species by the transfer of electronic charge and may undergo further transformations including rearrangements, reaction, and phase changes.

A further object of the present invention is to provide a new use of the basic technique of using electricity to drive a redox process within a reactor device to produce in situ a reactive product that is reacted within the device as part of a synthetic reaction.

Operation of reactor devices according to the present invention involves a number of transport processes that are affected by the construction and dimensions of the reactor device so that the preferred dimensions are within the range appropriate for micro-engineering techniques. Processes involved typically include electro-migration, electrodeposition, and diffusion of materials and reagents to reaction sites such as electrodes and electrodeposits, mixing of fluid reagent streams, reaction, and heat generation or consumption and heat transport. As described later, the conditions for rapid ion migration, material transfer by diffusion, and heat transfer across fluid layers in a reactor, are improved, and the ratio of reaction flux to reaction zone volume can be enhanced where cross layer thickness are in the microengineering range from 1 μm to 1000 μm , and preferably in the range 30 μm to 300 μm .

According to one aspect of the present invention there is provided a micro-engineered reactor device that is suitable for the electrochemical synthesis of organic compounds.

According to another aspect of the present invention there is provided a method of using the micro-engineered reactor for the purpose of manufacturing organic compounds.

The present invention will now be described by way of examples, with reference to the accompanying drawings, in which: -

Figures 1a and 1b show schematically, two types of micro-engineered reactor device incorporating the present invention.

Figures 2 to 17 show schematically micro-engineered reactor devices incorporating embodiments of the present invention.

In the Figures 1a to 17 the reactor devices are shown in cross section such that channel heights and lengths are represented schematically. Channel widths are not indicated but may be similar to the heights of the reactor, or greater, up to the limits imposed by widths of materials or substrates used to fabricate reactor devices.

5

In general terms, the present invention has a wide application to the synthesis of organic compounds by reaction with a reactive primary product generated electrochemically from a source material. In general terms a source material is electrochemically converted to a reactive primary product which is exposed to a precursor material at a reaction region within a channel, or chamber, so that the primary product and precursor material react to generate a secondary product. For, example, the precursor material may consist of, or include a fluid organic reagent. The organic reagent may be dissolved in a solvent. In one example, the primary product is a reactive metal electrochemically generated from a source material which may be a salt or other redox active compound of the metal. The precursor and primary product react to form a secondary product, which may be an organometallic compound.

10
15

The source material may be resident at, or adjacent to, an electrode and may be transferred to the electrode region by fluid flow. Preferably the source material is one that is mobile and may possibly be dissolved in a solvent. The source material will preferably be a salt or other redox active compound capable of being converted by electrolysis to form the primary product.

20

The reactor device may include provision for reaction of the secondary product with further reactants, either within the channel, or chamber, where the secondary product is formed, or in other channels, or chambers, to which the secondary product is conveyed by fluid flow. The device will have not less than two spaced electrodes, the working and counter electrodes, between which an ionically conductive material is presented, and an electrical current passed through the electrodes and the intervening ionically conductive materials (or phases) during the electrochemical generation of the primary product. The primary product is formed electrochemically at the working electrode. Other redox processes will occur at the counter electrode.

25
30

The ionically conductive material may consist of, or include the source material and may include solvents and supporting electrolytes and redox active material to support electrochemical processes at the counter electrode. Solvents used for source material, supporting electrolyte, and precursor material, may be the same or different materials, and may be miscible or immiscible. Polar aprotic solvent may be especially favoured for providing

35

ionically conducting phases.

The process carried out in the micro-engineered reactor device will be a combination of an electrochemical redox process which generates a primary product, such as a reactive metal deposit or other highly reactive or unstable electrochemically generated species, and
5 reaction of the primary product with supplied reagent or precursor material to generate a secondary product such as an organometallic species, within the same micro-engineered reactor device, or similar micro-engineered reactor devices.

10 Although the preferred embodiment of the invention is intended for the synthesis of organometallic compounds by the electrochemical generation of reactive metals as primary products and their reaction to produce organometallics as secondary products, the generation of non metallic primary products for subsequent reaction is included. Such primary products may be electrochemically generated non-metallic materials, including
15 elements and compounds, and may include species or materials generated by direct electrochemical oxidation or reduction of organic species including organic ions, and may include free radical species. Primary products may remain at least temporarily where formed at, or adjacent to, an electrode until exposed and reacted with precursor material to form secondary products that may be conducted from the reaction site by fluid flow. Alternatively,
20 primary products generated in a first part of the reactor device, or similar micro-engineered reactor devices, may be carried dissolved, or in suspension, in a fluid phase (e.g. as particulate or colloidal metal), and conveyed by fluid flow from that first part of the reactor device, or devices, to a second part for mixing and reaction to form secondary products. The secondary products may themselves be used as reactants to generate tertiary products
25 either within the device or after transfer to another device or environment.

In some cases, it may be that the processes of formation of primary and secondary products and any intermediate forms are not resolved, and it is not necessary that they be resolved to achieve the purpose of the invention.

30

In the preferred embodiments of the invention, the proposed micro-engineered reactor device has conduits to carry one or more reactant solutions into a chamber containing one or more electrodes and transfer product solutions from the chamber. The conduits and chamber are formed by micro-engineering techniques.

35

The active metals for use in the synthesis of organometallic species can be generated electrochemically and it is an advantage of the proposed reactor devices that such material

is generated in situ as a primary product for reaction with a precursor reagent. Application of the precursor reagent to the electrolytically generated primary product is performed either immediately or after a short delay, producing a secondary product such as a reactive organometallic species. The reactor device may be a convenient source on demand of reagents such as organometallics from readily available and non-hazardous precursors. A further advantage is that the secondary products may be utilised in situ avoiding storage losses and hazards.

The reactor devices proposed allow a series of source or precursor materials or reagents to be brought together in a controlled manner with electrolytic processes applied only as required. It is thus possible to employ redox active reagents and generate redox active products whilst controlling which are exposed to electrochemical conversion processes.

Electronic circuits for passing charge through the reactor device may be operated to control potentials and current and vary these over time. These may include potentiostatic and galvanostatic circuits.

Reactor devices according to the present invention may be operated in two modes. In the first mode (hereinafter called "the continuous mode", the electrochemical generation of primary product and supply of precursor are carried out at the same time allowing continuous reaction and generation of secondary product. In the second mode, hereafter called "the discontinuous mode", the electrochemical generation of primary product is carried out in a first time period and supply of precursor carried out in a second time period. Primary product is accumulated in the first period and reaction of accumulated primary product with precursor to generate secondary product occurs within the second period. First and second periods may be repeated alternately. Other time periods may separate first and second, and second and first periods. Flushing or cleaning solutions may be applied to the reactor device during these other periods. Operation in discontinuous mode allows different solvent systems to be used during the processes of primary product formation and of reaction of primary product with precursor to form secondary product. This extends the range of chemistries, which can be used as the optimum conditions, and solvent environment may not be the same for the processes of primary product formation and of reaction of primary product with precursor to form secondary product.

Two basic geometries or types are preferred for the reactor devices of the present invention. Devices of the first type or geometry (shown schematically in Figure 1a) incorporate an electrochemical cell, where at least some of the space between the working and counter

electrodes is occupied by fluid containing source material, ionically conductive material, and redox active material to support electrochemical processes at the counter electrode, which materials may be the same or different, such that an ionically conductive path links the electrodes to carry current between the electrodes, and that space is also occupied by a precursor for the reagent to be generated, either at the same time or at different times as discussed above. The electrodes may be disposed on opposite sides of a chamber or flow channel as indicated diagrammatically in Figures 1a and 1b or side by side on a wall of chamber or flow channel.

Reactor devices of the second type or geometry (shown schematically in Figure 1b) incorporate an electrochemical cell where the space used for ion conduction during the electrochemical generation of the primary product, and the space for precursor addition and transfer, are separated by a structure which at least includes an electrode structure at which the primary product is generated, and where such separating structure allows for material transfer enabling primary product and precursor to be brought together.

Devices of the second type or geometry may be run in continuous or discontinuous mode as for devices of the first type or geometry. With the second type of geometry, there is no need to clear electrolyte out of the precursor or product fluid flow path. However, it may be convenient to run the device in a discontinuous, or pulsed, mode, to allow sufficient primary product (such as alkali metal) to build up on the working electrode, or allow alternation of supply of precursor material, and of source material where the source material is supplied as a fluid, and that fluid is different to that for precursor supply, or to allow changes in the solvent used for transporting precursor to the working electrode and the product from the working electrode.

Structures with multiple fluid inlets and outlets may also be used for devices of the second type or geometry.

Referring to Figures 1a and 1b, the reactor device, of the first type is shown schematically in Figure 1a, and comprises a chamber 11 in which are located two electronically conductive structures or substrates that form two electrodes, the working electrode 13, and the counter electrode 14. In use the electrodes 13, 14 are connected to an electrical supply so that a potential is applied between the electrodes 13, 14. The chamber 11 has an inlet 12 for receiving one or more fluids, which fluid or fluids are utilised in electrochemical product formation and reaction in chamber 11.

A first fluid entering chamber 11 consists of, or contains, an ionically conductive material, and a source material such as, for example, a metal salt dissolved in an organic fluid, so that there exist an ionically conducting pathway through chamber 11 between electrodes 13 and 14. Consequent to current passage between electrodes 13 and 14, the electrochemical formation of a primary product such as, for example a metal, causes the metal 16 to deposit on the electrode 13.

A second fluid entering chamber 11 that may be the same as the first fluid or combined with the first fluid stream, consists of, or contains, a precursor reactant, (such as, for example, an alkyl halide). The precursor reagent reacts with the primary product to form a secondary product, (such as, for example, an organometallic compound). The second fluid (precursor reactant) flows through chamber 11 along a fluid pathway 17 adjacent to electrode 13 that may occupy all, or part only, of chamber 11.

The primary product 16 electrochemically deposited on one or more surfaces of the substrate 13 is, in use, exposed to the precursor reagent in the chamber 11. The primary product 16 reacts with the precursor reagent to form the secondary product. The source material and the ion conductive material may be the same, or different, materials, and if different materials, they must both be present in the chamber 11 when current is passed to form primary product 16.

The source material and precursor material may be conveyed in the same or different fluids, at the same time or at different times. The chamber 11 has an outlet 15, through which reaction product such as, for example, an organometallic compound is removed. Spent fluid or fluids containing depleted source material and precursor reagent may leave chamber 11 through outlet 15. The function of inlet 12 and outlet 15 may be changed from time to time by reversing fluid flow through chamber 11.

The second type or geometry of reactor device is shown schematically in Figure 1b. In this type of device the volume used for ion conduction is separated from that used for precursor addition and transfer.

The reactor device of the second type comprises a chamber 11 in which is located two electronically conductive substrates forming electrodes, working electrode 13, and counter electrode 14. In use the electrodes 13, 14 are connected to an electrical supply so that a

potential is applied between the electrodes 13, 14. The chamber 11 has an inlet 12 for receiving one or more fluids which are carried through chamber 11 to an outlet 15 along a fluid pathway 17 adjacent to electrode 13 but not between electrodes 13 and 14.

5 The reactor device of the second type shown in Figure 1b involves a separation of the volumes within the chamber 11. The volume 11a that is used for ion conduction is separated from the volume 11b that is used for the reaction of the precursor and reagent addition and transfer of the products of the reaction by the working electrode 13 which is permeable to allow material transfer across the electrode 13. In this way the primary product and
10 precursor reactant are brought into contact within the volume 11b to form secondary product which may be transferred into the adjacent fluid flow path 17.

The permeability of the electrode 13 may be achieved by using as structure with pores, or vias, such as a mesh or an array of strips, or by using an electrode material that is inherently
15 permeable to the primary product or the fluid containing precursor reagent and secondary product.

A further requirement of the second type of geometry is that a counter electrode 14 is located within the chamber 11, but out of the flow path 17 of the precursor reagent, and that
20 that region 18 of chamber 11, between electrodes 13 and 14, contains ionically conductive material, at least during the electrolytic generation of primary product 16 at electrode 13.

Region 18 may be furnished with inlet and outlet tubes not shown in Figures 1a and 1b, or may be occupied by a static ion conductive phase which may be a fluid, semi-solid, or solid
25 ion conductor. The ion conductive phase may contain or consist of the source material. Source material for electrochemical conversion to primary product may be introduced to region 18 or the flow path 17 depending on the selected chemistry. Preferably this arrangement allows primary products, produced at the working electrode 13 by the electrochemical reaction on the source material by passage of electrical current through the
30 ion conductive material between electrodes 13 and 14, to be presented through the electrode 13 and interact with precursor reagent in the adjacent flow path 17.

Electrical current passage between electrodes 13 and 14 through region 18 of chamber 11 causes electrochemical formation of a primary product such as, for example, a metal deposit
35 16, at electrode 13. The fluid entering chamber 11 along flow path 17 adjacent to electrode

13 is, or contains, a precursor reactant such as, for example, an alkyl halide, to form a secondary product such as, for example, an organometallic compound, by reaction with the primary product.

5 The fluid pathway 17 may not occupy that part of chamber 11 between electrodes 13 and 14. The primary product 16 electrochemically deposited on one or more surfaces of the substrate 13 is, in use, exposed to the precursor reagent in the chamber 11. The primary product 16 as, for example, a sacrificial layer of a metal on electrode 13 will react with the precursor reagent to form the secondary compound.

10

As explained above with regards to devices of the first type, with devices of the second type, the source material and precursor material may be conveyed in the same or different fluids, at the same time or at different times.

15 The chamber 11 has an outlet 15, through which reaction product such as, for example, an organometallic compound is removed. Spent fluid or fluids containing depleted source material and precursor reagent may leave chamber 11 through outlet 15. The function of inlet 12 and outlet 15 may be changed from time to time by reversing fluid flow through chamber 11.

20

For devices of both the first and second type, the source material and ion conductive material may be the same, or different, and if different, must both be present in the chamber 11 when electrical current is passed between the electrodes 13, 14 to form primary product 16. The source material and precursor material may enter the chamber in the same or
25 different fluids at the same or different times.

The primary product 16 is generated from the source material by charge transfer at the working electrode 13. Where the primary product 16 is generated by a reductive process, as where the primary product is a metal produced by electrochemical reduction of a metal salt
30 or compound at the working electrode 13, that working electrode is connected as a cathode. This is achieved by connecting the electrodes 13 and 14 of the electrochemical cell into an external electrical circuit which maintains a potential bias between the electrodes such that conventional current flows from the working electrode 13 into the external circuit. Most generally this corresponds to the working electrode 13 as cathode being biased at a potential
35 negative with respect to the counter electrode 14 as anode as indicated schematically in

Figures 1a and 1b.

Alternatively, where the primary product 16 is generated by an oxidative process, as where the primary product is for example a halogen generated from a halide salt source material at
5 the working electrode 13, that working electrode is connected as an anode. This is achieved by connecting the electrodes 13 and 14 of the electrochemical cell into an external electrical circuit which maintains a potential bias between the electrodes such that conventional current flows from the counter electrode 14 into the external circuit. Most generally this corresponds to the working electrode 13 as cathode being biased at a potential positive with
10 respect to the counter electrode 14 as cathode.

In operation the primary product 16 such as, for example, a sacrificial metal layer is electrochemically deposited on the electrode 13 by connecting the electrode 13 as a cathode and the electrode 14 as an anode in an electrical circuit. An ionically conductive material is
15 presented in the space between the electrodes 13 and 14 and a source material that may be a salt or redox active compound of the metal is presented at least to the working electrode 13. Application of a potential difference between the electrodes 13, 14, causes an electrical current to flow between the anode and cathode, thereby causing the primary product 16 (such as, for example a metal) to be electro-deposited on the working electrode 13.
20

In discontinuous mode operation, the electrochemical generation of primary product 16 is carried out in the absence of precursor reagent until sufficient primary product has been deposited on the working electrode 13. The electrical potential maintaining current through the cell between the anode and cathode is removed, and the organic precursor reagent is
25 caused to flow through the chamber 11 along flow path 17 to react with the primary product 16. This mode of operation is effectively a "discontinuous" or batch process.

In the embodiment just described, the primary product 16 is deposited prior to introducing the precursor reagent into the chamber 11. In an alternative embodiment, continuous mode
30 operation, the primary product 16 may be electrochemically generated at the same time as carrying out the passage of precursor reagent through fluid path 17 and reaction of the precursor reagent with the primary product 16. This mode of operation is effectively a "continuous" process.

Operation of various embodiments of the invention and the structures of various micro-engineered reactor devices constructed in accordance with the present invention, are illustrated in Figures 2 to 17.

- 5 Figure 2 shows schematically a continuous process in a reactor of the first type where there is a continuous flow through the chamber 11 of ionically conductive reagent mix containing source material, which may be a salt (e.g. M^+Y^-) and a precursor reagent (e.g. R-X). Source material (e.g. M^+Y^-) is caused to flow in flow path 17 between energised electrodes 13 and 14 to produce electrolytic primary product 16 (e.g. M^0) in flow path 17 at or adjacent to
10 electrode 13, which primary product can then react with organic precursor reagent (e.g. R-X) to produce useful secondary product (e.g. M-R). The primary product is formed on the working electrode as an adherent deposit (as represented schematically in the upper half of Figure 2), or it may pass into the fluid flow as solution or suspension as represented schematically in the lower half of Figure 2. It is not necessary that an electrolytic
15 intermediate primary product 16 (e.g. M^0) be identifiably formed. The useful secondary product (e.g. M-R) may be carried by fluid flow to a subsequent junction 19 to which a further reactant (e.g. R'-W) is brought through conduit 20 for mixing and reaction (e.g. $M \rightarrow R-R'$). Tertiary product R-R' is carried away in flow through output conduit 21. Reagent R'-W and tertiary product R-R' may be compounds which would be subject to alteration if they passed
20 through the electrochemical cell section e.g. where R'-W could not be introduced in the feed stream to the electrochemical cell. The simplest structure achieving the above is represented diagrammatically in Figure 2 where the indicated process involves reduction of M^+ at the negatively polarised working electrode 13 operating as the cathode.
- 25 Alternative processes may involve reaction with primary product 16 formed by an oxidative process (e.g. Cl_2 generated from source material containing Cl^-) formed where the positively biased working electrode 13 operates as the anode.

Although electrochemical conversion of a singly charged positive ion M^+ is shown, the
30 process is applicable to source materials containing multiply charged, negatively charged, and even neutral species as long as they are electrochemically active. The charge and the relative importance of electrophoretic migration, diffusion, and advective processes may affect the material transfer to electrodes. In the simple structure shown schematically in Figure 2, the anode and cathode both directly contact the reagent stream and products from
35 both the anodic region and the cathodic region will be carried into subsequent reaction

zones. These may include side products from both anodic and cathodic electrode regions. Side products from the counter electrode 14 that are not directly involved in the required reaction may be diverted from subsequent reaction zones by suitable flow arrangements.

5 Methods of diverting unwanted products from the reactor zones are indicated diagrammatically in the device of Figure 3. This may involve separating flows from around the counter electrode 14 and the working electrode 13 with the required products leaving chamber 11 through outlet 15, and unwanted products from the region adjacent to electrode 14 passing along an output conduit 22.

10

Electrodes may be positioned outside the flow stream leading to subsequent reaction sites as indicated in Figure 4:

As indicated in Figure 4, the counter electrode 14 may be positioned in an outlet conduit 22 15 outside the flow stream 17 adjacent to electrode 13 as long as a sufficiently ionically conductive pathway can be maintained between electrodes 13 and 14. Unwanted products are carried away through conduit 22 without contaminating the desired products passing through outlet 15.

20 As in indicated Figure 5, the feed streams to the anode 14 and cathode 13 may be different, with flow of source material and precursor reagent from inlet 12 flowing into the chamber 11 adjacent to electrode 13, and fluid from inlet 23 flowing past electrode 14. The two fluids may be of different composition and may be immiscible as long as both have sufficient ionic conductivity to maintain a conductive path between anode 14 and cathode 13.

25

As well as separating the products from the two electrodes by flow arrangements as indicated above, the fluid paths could be controlled by addition of an ion permeable barrier between the anodic and cathodic regions. This might be a porous sheet, dialysis membrane, ion exchange membrane, or region of gelled or otherwise immobilised electrolyte.

30

As well as separating the products from the two electrodes 13, 14 by flow arrangements as indicated above, the fluid paths could be controlled positioning an ion permeable barrier 24 between the regions adjacent to the electrodes 13, 14. This barrier 24 divides the chamber 11 into cathode and anode compartments as shown in Figure 6. The barrier 24 could be a

porous sheet, dialysis membrane, ion exchange membrane, or a region of gelled or otherwise immobilised electrolyte.

One or more of the electrodes may be constructed as a porous or mesh type electronically
5 conductive structure as shown in Figure 7. This can increase electrode surface area and a porous body may be used to establish a region within the chamber 11 through which part of the fluid passes. Within a porous electrode structure the diffusion and thermal conduction distances through solution to the electrode material are decreased. In the device of Figure 7 the working electrode 13 for primary product formation and reaction takes the form of an
10 electronically conductive porous body. Such a porous electrode could be used in combination with an ion permeable membrane of the type represented in Figure 6.

In the reactor devices shown in Figures 2 to 17, the dimensions of the channels through which the fluids flow, are such that reagents flowing past the working electrode 13 or
15 electrode 14 may effectively be carried, for example, by diffusion, to the electrode surface to react with the respective electrode. The electrodes 13, 14 may form part of the channel wall (as shown in Figures 2 to 6) or may be discrete structures separate from the channel or chamber walls. The electrodes may additionally be constituted as porous blocks or meshes of electronically conductive material. Fluid may be passed over the surface of a porous
20 electrode or be pumped to flow through the porous electrode so that electrode processes and electrode position may occur at the pore walls.

Variants with porous electrodes may be based on other options described here and used with continuous or discontinuous operation.

25

Although shown for continuous operation, the structure of Figures 2 to 7 above may also be employed for discontinuous operation. In this mode, an electrical current is passed between the electrodes 13, 14 to produce a primary product, for example a metal such as lithium, which is retained at, or adjacent to the working electrode 13. The region adjacent electrode
30 13 is thus loaded with the primary product. Subsequently, a precursor reagent, or solution of that precursor reagent, is presented to the electrode 13 that is loaded with primary product, such that, the reagent reacts with the primary product to produce a secondary product.

The reaction between primary product and precursor reagent need not involve electrical
35 current passing through the device, and the precursor reagent solution need not be ionically

conductive. This secondary product may dissolve in a fluid containing the precursor reactant, and may be carried by that fluid to a further reaction site within the device. Alternatively, the primary product when formed may be deposited within the chamber 11 or outlet channel 15 or in a receptacle at the exit from outlet channel 15.

5

Another fluid may be passed in contact with the secondary product, either deposited in the device or held in the fluid in which it is generated, to receive the secondary product by dissolution or transfer between fluids, and carry the secondary product from the electrode region, and that flow may carry the secondary product to a further reaction site externally or
10 within the device.

Operation of a reactor device in discontinuous mode using two fluids passing alternately through the reactor device is illustrated in Figure 8.

15 In Figure 8A, an ionically conductive solution from inlet 23 (solution of M^+Y^- , e.g. a Lithium salt) flows through the chamber 11 and an electrical current is passed between the electrodes 13, 14, to cause the accumulation of a primary product 16 (M^0 e.g. deposition of Lithium metal at the cathode) at the electrode 13. Once sufficient deposit has built up, the electrical current is stopped, and the fluid flows are changed, as indicated in Figure 8B, so
20 that electrolyte flow from inlet 23 is terminated and a precursor reagent fluid (R-X solution) is introduced through inlet 12. The reagent fluid reacts with the primary product 16 deposited on cathode 13 generating a product which is carried to a junction 19 with a second reagent flow from inlet conduit 20 allowing mixing and reaction at and beyond the junction 19.

25 As represented in Figures 8A and 8B, the junctions between different fluid flows are open, and flow control is exercised by changing pressures and flows at the inlets 12, 23 and 20. For micro-devices this is often adequate, and may be used where a small level of contamination of one fluid with another may be tolerated. It may however be advantageous to insert valve structures at one or more of the junctions inlets 12, 23 and 20 to control the
30 flows of fluids and to control contact between the fluids.

In those instances, where the solution conveying the precursor reagent to the electrode 13 loaded with primary product does not dissolve or carry away the secondary product that is formed, a third fluid may be introduced into the cycle through an inlet 24 as indicated in
35 Figure 9. The use of a third fluid stream may prove useful even where the product can be

dissolved or carried away in the second fluid. Greater control and flexibility of system operation may be achieved by interposing a solvent or different fluid between the ionically conducting fluid introduced through inlet 23 and a precursor introduced through inlet 12. This may also ensure that mixing between those fluids is minimised thereby reducing product contamination and side reactions.

Arrangements for linking inlets 12, 20, 23, or 24 of various fluid sources may be chosen for convenience in fabrication or sequence of operation as shown in Figure 10, and may include use of valves 25 as shown in Figure 10. In Figure 11, the valve is shown as a rotary valve for selectively connecting one of the inlets 12, 23, or 24 to the chamber 11.

Figure 12 shows a reactor device of the second type or geometry based on the design represented in Figure 1b. In the reactor device of Figure 12 the chamber 11 is divided by the electrode 13, into a region 18 containing ionically conducting material for providing an ionic conduction path for electrolysis and a fluid path 17 for carrying the precursor reagent. Regions 17 and 18 are separate but adjacent, and are separated by a permeable working electrode 13, which must be porous, or otherwise permeable, to allow primary product 16 and precursor reagent to contact and react to form the secondary product.

As shown in Figure 12, fluid flow along pathway 17 carries secondary product to junction 19 to mix and react with another reagent from entrance 20. The working electrode 13 may be in the form of a porous block through which fluid flowing along the flow path 17 passes in a manner similar to that shown for devices of the first type in Figure 7. Similarly, the counter electrode 14 may be in the form of a porous block through which are passed ionically conductive fluid containing material to support electrochemical processes at the counter electrode. Similarly there may be multiple entrances to that part of the chamber 11 occupied by fluid flow 17 so as to allow changes of reactant and solvent in a similar way to that described above in relation to that the devices of Figures 9 and 10. Such arrangements may incorporate valves as in Figure 11.

In reactor devices of the type represented in Figure 12, ionically conductive fluid, which may contain source material for the electrolytic generation of the primary product and other species to support electrolytic reaction at the counter electrode 14, may flow to contact electrode 14. This fluid is brought into and out of region 18 of chamber 11 by conduits 26 and 27. Ionically conductive fluid may occupy region 18 up to the electrode 13, or there may

be a solid or semi-solid ion conductor layer 28 intervening between the ionically conductive fluid and electrode 13 as shown in Figure 12.

Figure 13 shows schematically a variation of the reactor device of Figure 12 in which there is provided a permeable layer of ionic or electronic conductor 29 between a fluid ion conductive solution contacting electrode 14, and ion conductor layer 28, which may be fluid, solid or semi-solid, contacting electrode 13. Also represented in Figure 13 is a variation on the construction of electrode 13 such that it takes the form of a mesh or set of interconnecting strips allowing deposition of primary product 16 over the surface of ion conductor 28 in the
5
10
15
20
vias through electrode 13. The permeable layer 29 may be an electronic conductor such as, for example, Mercury (or a structure containing Mercury or an amalgam) where the transferring species is a mercury soluble metal such as sodium. Presence of a selectively permeable layer as indicated for layer 29 allows use of chemically incompatible ionically conductive materials on either side of the layer. For example an aqueous salt solution can contact electrode 14 and sodium beta alumina contact electrode 13 but the two electrolytes should not directly contact due to hydrolysis reactions which would damage the sodium beta alumina. An intervening layer chemically compatible with both ion conductive layers and which transfers sodium or sodium ions allows use of such chemically incompatible layers in combination. In principle multiple layers of conductors with suitable permeability and chemical compatibility may be employed.

In principle, the reactor devices of the second type may be used with both solid and fluid electrolytes, but it is advantageous to employ ionic conductor adjacent to the working electrode 13 which is either a solid or semi-solid such as an electrolyte fluid immobilised by a porous structure or gel. The arrangements represented in Figures 12 and 13 may be used
25
30
for carrying out a process such as organometallic reagent production. Electrolysis in the ion conduction pathway section generates reduction product M^0 (e.g. Lithium metal) at the porous electrode, which reacts with precursor R-X (e.g. an alkyl halide) generating the reagent M-R (e.g. alkyl lithium compound). Side products including M-X (e.g. lithium halide) may also be produced. Product M-R and side products generated in the same region may be carried away in the fluid flow as shown in Figures 12 and 13.

A variety of structures and materials may be used to form the electrolytic cell and ion conducting pathway as long as they maintain ionic or electronic continuity between

electrodes 13 and 14 and allow transfer of species required to allow the electrolytic formation of primary product at electrode 13.

Truly solid-state ion conductors based on ceramic or crystalline materials tend to have transport number at or near 1 for the mobile ion, which reduces problems with concentration polarisation within the electrolyte. Examples such as β -Alumina, or Nasicon are attractive as Na^+ conductors with transport number of 1. Conductivities rise with temperature but values as high as $\sim 10^{-3}$ siemens/cm at room temperature are achieved so that limitations on throughput due to low conductivities are not excessive. Lithium and potassium analogues of the ceramic sodium ion conductors also, though usually with somewhat lower conductivities. Li_3N crystals have high Lithium ion conductivity perpendicular to the c axis. A range of Lithium conductors based on mixed oxide (Si, Ge, P, Zn, Ge, and V) matrices is also known. Other truly solid ion conductors are for Ag^+ , Cu^+ , H^+ cations, and F^- , and O^{2-} anions. The anionic conductor, such as LaF_3 , and doped ZrO_2 are likely to prove of limited utility for organic synthesis due to relatively low conductivity at moderate temperatures, but may be applicable for high temperature reactions. Some Ag^+ ion conductors, especially those related to AgI (e.g. silver rubidium iodide) have quite high conductivities, and may be useful in formation of organo-silver compounds or as electrolytes for use in combination with other source materials for generating other organometallics. Cu^+ conductors are also known but are generally of lower conductivity than analogous Ag^+ conductors. Solid state proton conductors have conductivities which in many cases depend on the presence of water and for the most part will be limited to use with water compatible chemistries, may provide a means of carrying out electrochemical hydrogenations or even dehydrogenations in devices of the second type or geometry.

Polymer based ion conductors are widely applied in the battery industry for Li^+ ions in particular. They are probably more truly immobilised liquid electrolytes as there is some anionic migration that can lead to polarisation. Examples have been applied in rechargeable systems where Li metal is deposited as either free metal or within graphitic matrices. There may be more limitations with the use of such polymeric systems arising from polymer and Lithium salt solubility in the fluid used to carry precursor to, and product from the working electrode. Polymer and solvent systems may generally be characterised as ether/polyether type materials that could be compatible with a range of lithium metal based organic synthetic processes. Lithium ion conductors in combination with graphite matrices to form Lithium or

other species permeable electrodes are suitable for use in devices of the second type or geometry.

5 The same liquid electrolytes used for reactor devices of the first type or geometry may be used in devices of the second type or geometry with the porous working electrode, perhaps on a porous substrate, held at the interface between the electrolyte and precursor/product transport fluid(s). This may be an immiscible fluid interface or may exist as a graded interface within the porous electrode where the fluids are miscible or have some mutual solubility.

10

The reactor device of the present invention can link to a mixer / reactor stage for rapid consumption of the product reagent as indicated in Figures 12 and 13.

15 The counter electrode 14 within the electrochemical cell will require a source of the ions to be transferred. This may be provided by the electrode material itself (e.g. if it is an alkali metal, or alloy or amalgam of an alkali metal, or an electronically conductive intercalation compound of an alkali metal). A solution of the relevant ions may be provided as a layer adjacent to the counter electrode and waste products removed to avoid polarisation and contamination problems. This replenishment, either continuously or intermittently may be
20 achieved as indicated in Figures 12 and 13 through conduits 26, 27.

Although the number of types of ions which may be used within the ionically conductive phase in the electrochemical cell may be quite limited, it will be possible in some cases to generate organometallic reagents of other metals by providing those metals in compounds
25 within the flow 17 adjacent to electrode 13. These source materials in solution may be employed either alone or simultaneously with precursor reagent as indicated earlier for discontinuous or continuous mode operation of the synthetic devices.

30 Figures 1a to 12 and the description pertaining to those figures have shown only two electrodes in each device. It is to be understood that that reactor devices according to the invention may have, and could be constructed with, multiple electrodes carrying out the functions of the working electrodes 13 and counter electrodes 14 shown in Figures 1a to 13.

35 As shown diagrammatically in Figure 14, further electrodes 30, 31 may be incorporated to carry out other functions. One or more reference electrodes may be incorporated in a device

to allow the monitoring and control of the working electrode potential. Such a reference electrode will contact the ionically conductive phase between electrodes 13 and 14, and where it is to be used as part of a circuit to control working electrode potential, then the reference electrode 30 will most usually be placed relatively closely to electrode 13 as shown
5 in Figure 14. Other electrodes 31 may be positioned in the fluid flow stream to monitor potentials which allow sensing of fluid composition, and other non electrochemical sensors, for example optical or thermal sensors, may also be used. In operation the output from sensors in the device may be used to control potentials applied and current passed through the device and to control fluid input and output rates.

10

As shown diagrammatically in Figure 15, a heat exchanger structure 32 may be incorporated in the device. Such thermal control structures may include fluid cooled or heated structures as well as electrical heaters and Peltier coolers and multiple heat control structures may be distributed throughout the device. Such thermal control structures may be positioned
15 adjacent reaction zones as indicated schematically in Figure 15 where a heat exchanger is shown adjacent to the chamber 11 and particularly adjacent one or more of the electrodes, and a further heat exchanger structure 33 adjacent to the reaction zone following junction 19.

20 As shown diagrammatically in Figure 16, where the primary product 16 is not deposited adherently to the working electrode 13 but taken up into the fluid flow 17, fluid consisting of or containing precursor reagent may be passed into the reaction chamber at a junction 34 through an entry conduit 35 downstream of the primary product generation region to mix and react with the primary product at and adjacent to the junction 34.

25

As shown diagrammatically in Figure 17 the region where primary product is formed and or reacted with precursor reagent may be subjected to some radiative stimulus e.g. UV light through a window or aperture 36 from a source 37. Such stimulus may be to enhance formation or reaction of the primary product or as part of a sensor system to monitor
30 reaction.

The use of additional electrodes, thermal control structures, and supplementary radiative stimulus as represented in Figures 14, 16, and 17 may be applied to devices of both first and second types.

35

In reactor devices of the second type the face or surface of an electrode at which the primary

product is formed may be different to that to which precursor material is initially presented. In such arrangements the electrode structure at which primary product is formed must be such as to allow material transfer between faces or surfaces of the electrode to enable contact between primary product and the precursor material. Electrodes that are permeable to the primary product may achieve this or where electrodes are formed with materials or structures providing pores or vias through the electrodes through which primary product or precursor or fluids containing primary product or precursor can pass. Physical pores or vias may be provided by forming the electrodes from porous materials or as meshes or strips.

Where the primary product is an amalgam forming metal, the electrode permeable to the primary product may be formed at least partially as a film or layer of Mercury. A porous body or sheet of material that is wetted by mercury may support the mercury layer. Graphite is permeable to some metallic and some non-metallic species such as Lithium and Fluorine, and Graphite layers or films may be used to form permeable electrodes where such species are the primary product. Where the primary product is hydrogen, the electrode permeable to the primary product may be formed as a film or layer of Palladium or other metals (e.g. Lanthanides, and their alloys, Misch metal) having high hydrogen permeability. Hydrogen permeable metals may act as catalysts for the hydrogenation or reduction of precursor reagents.

Most generally, the materials used for electrode construction in the devices will conduct electrical charge exclusively by electronic means. Such electrode materials include metals, many semiconductors, conductive carbons, and some electronically conductive polymers and ceramics. In device of second type geometry with such electrodes the primary product must be formed at a contact between the electrode and ionically conductive material. In such cases the electrode must be permeable to the primary product or be formed with materials or structures providing pores or vias through the electrodes through which primary product or precursor and secondary product, or fluids containing products or precursor can pass.

Alternatively the materials used for electrode construction may be mixed conduction materials. Mixed conduction materials are those which are able to conduct electricity by both ionic and electronic pathways. In devices of second type geometry the ionic conductivity of such mixed conduction type electrodes can allow generation of the primary product at the face away from the ion conductive material which constitutes the electrolyte layer in the electrochemical cell. Where such mixed conduction electrodes are used the electrode within a device of second type geometry need not be permeable to primary product or precursor or secondary product or solutions thereof. Tungsten bronzes are a well-known class of mixed

conduction material. Sodium tungsten bronzes, which may be represented by the formula Na_xWO_y , have composition ranges where both electronic and Na^+ ion conduction occurs.

In the reactor devices show in Figures 1a to 17 the face, or surface, of an electrode at which the primary product is formed may be the same as that to which source material is presented. This will usually be the case where the source material is supplied to the same surface or face as the ionically conducting phase intervening between electrodes through which the electrolytic current is passed. This will include cases where the source material constitutes part of the ionically conducting phase.

Alternatively, in reactor devices of the second type, the face, or surface, of an electrode, at which the primary product is formed, may be different to that to which source material is initially presented, so long as the electrode structure, or material, is such as to allow transfer of the source material to the site of primary product formation. This may be achieved by electrodes that are permeable to the source material, or fluid containing the source material, or where the electrodes are formed with pores or vias passing through the electrodes through which source material, or fluids containing source material, can pass. Physical pores or vias may be provided by forming the electrodes from porous materials or as meshes or strips.

The source material may be a salt or redox active compound for conversion to the primary product, or fluid containing source material and is preferably at least part of the ionically conductive material intervening between electrodes during the electrochemical generation of primary product. The source material which is converted electrochemically to the primary product may provide all or part of the ionic conductivity, or the ionic conductivity may be provided by supporting electrolyte ions which may not be involved in the electrochemical process at one or more of the electrodes.

Alternatively, the source material or that fluid containing source material, and the ionically conductive material between the electrodes may be different provided that, during the electrolytic process, the source material can access at least part of the junction between ionically conductive material and any electrode at which the primary product is to be formed. This may be achieved where the source material and ionically conductive material, each of which may be in solid or fluid form, both contact the same electrode surface. The source material and ionically conductive material may be either mixed miscible or immiscible phases or contact the electrode as strips or streams.

Alternatively access by source material to at least part of the junction between ionically
conductive material and any electrode at which the primary product is to be formed may be
achieved by electrodes at the boundary between the source material, or fluid containing the
source material, and the ionic conductor material being formed as strips or meshes or with
5 pores or vias through the electrode or where the electrode material is permeable to the
source material. The ionically conductive material may be a fluid or alternatively may be a
solid such as a ceramic ion conductor or semi-solid material such as an ion conductive
polymer or gel. Alternatively a combination of solid or semi-solid, and fluid ion conductive
phases may be used as an ion conductive structure or assembly of phases intervening
10 between electrodes to allow electrochemical generation of the primary product. The solid or
semi-solid ion conductor materials may contain mobile species that are converted at an
electrode to the primary product. The mobile species within a solid or semi-solid ion
conductor which are converted at an electrode to the primary product may include the ions
which maintain conductivity, as for example the sodium ions in sodium beta alumina. Where
15 those mobile species constitute the source material, other supply of source material, in for
example a fluid phase, is optional. Additionally the electrode material may be a mixed ion
and electronic conducting material and the mobile ions within that constitute the source
material as long as they can be replenished from adjacent phases which may be the ion
conductive material or fluid containing the relevant ions or source thereof.

20

The reactor device of the present invention involves regions for electrochemical generation
of primary product, and for reaction of primary product with precursor reagent to generate
secondary product. These regions may be the same or different and further regions and
reaction zones and for mixing and reaction of products and reagents may be incorporated
25 into the device. The device may contain regions for controlling the temperature of the
electrochemical generation and reaction zones. Heat may be generated in the
electrochemical cell by the combination of current and cell resistance, by the electrochemical
transformations, and by chemical reactions such as those between primary products and
precursor reagents.

30

Operation of reactor devices according to the present invention involves a number of
transport processes that are affected by the construction and dimensions of the reactor so
that the preferred device dimensions are within the range appropriate for micro-engineering
techniques. Processes involved typically include electro-migration, electrodeposition, and
35 diffusion of materials and reagents to reaction sites such as electrodes and electrodeposits,
mixing of fluid reagent streams, reaction, and heat generation or consumption and heat
transport. In general, as will be shown below, rates of material transport and formation, and

transfer of heat from, or to, the fluids and reaction sites is improved by fabricating devices where distances across structures and fluid flows are small and fall within the range applicable to micro-engineering techniques.

5 Typically the generation of primary products involves electro-migration of ions carrying the electrolytic current and electromigration or diffusion of source materials to the electrode at which the primary product is formed. The primary products may remain where formed or transfer into a fluid flow to be carried to a separate reaction site. Within the ionically
10 conducting body or layer, heat will be evolved due to resistive heating at a rate given by the product of the current and the voltage drop. Heat may also be generated, or, less commonly absorbed, as a result of the electrochemical reactions at the electrodes including conversion of source material to primary product. Maintenance of a desired temperature regime will be aided by minimising thermal transport distances across fluids and walls to heat exchangers, heat sinks, or heat sources.

15

Precursor materials are brought by fluid flow to the primary product, either at the deposition site or a separate reaction site. In either case the precursor materials must be brought into contact with the primary product and this will typically involve diffusive transfer across the stream carrying the precursor material to transfer the precursor material to the surface of the
20 primary product or to mix the precursor material and primary product streams where both are held in a fluid phase. Rates of reaction between primary product and precursor can be transport limited, and such transport limitations on rates will be reduced by minimising material transport distances across fluid layers.

25 Some generation or absorption of heat will be associated with reaction of primary product and precursor material to produce a secondary reaction product. Where the primary product is a reactive material such as an alkali metal deposit the reaction will generally be exothermic. Whether heat is evolved or absorbed, maintenance of stable temperature regimes is improved by short thermal transport distances from the reaction site to heat
30 exchangers, sinks, or sources across intervening fluid layers and wall materials.

Reaction of secondary reaction product carried by flow to a further reaction site will similarly involve mixing, heat generation or absorption and heat transfer and enhancement of rates of diffusive transport and thermal conduction will be achieved by minimising the relevant
35 transport distances.

The speed and efficiency of each of the processes described is affected by the device

geometry and dimensions and preferably devices of micro-engineered dimensions are employed to enable rapid and efficient mass and heat transport.

5 For electrochemical reagent generation the preferred dimensions are governed especially by the requirement to maximise current to increase production rate while avoiding excessive voltage drops and heat generation within the body of the electrochemical cell and at electrodes. Close coupling of the electrochemical cell to cooling surfaces allows fast heat removal but the ionically conducting electrolyte layers should be sufficiently thin to ensure that heat generated within the electrolyte can be efficiently removed. For devices employing
10 relatively poorly ionically conductive non-aqueous electrolyte phases, it is desirable to minimise electrical resistance between electrodes by arranging that the electrolyte layer thickness should be low. This condition applies where the electrolyte is a fluid or for polymer immobilised electrolytes.

15 Ceramic ion conductors are commonly operated at elevated temperatures to increase ionic conductivity and their thermal conductivity is generally relatively high. However it is still preferable that such electrolyte layers are employed as moderately thin structures within the synthetic devices to reduce operating voltages required at the relatively low temperatures compatible with synthetic organic chemistry. Electrochemical reactions are located at or very
20 near electrode surfaces and the transfer of ions and source materials for generation of primary products is a controlling factor in the rate of product generation for devices according to the present invention.

As explained above, using micro-engineering techniques it is possible to form conduits or
25 flow channels with depth dimensions down to $\sim 1\mu\text{m}$. Though, in general, channels with depths of 10-100 μm are more conveniently fabricated, and allow significantly greater throughputs, and lower flow resistance. Channel widths and lengths are generally defined by lithographic techniques, and may range from a few micrometers to centimetre dimensions. By using combinations of such conduits or flow channels, transit and mixing times of the
30 order of seconds down to milliseconds in liquids, and microseconds in gases may be achieved.

Material transfer to and from electrodes across the ionically conductive electrolyte or flow streams may occur by either electromigration, or diffusion. For thin electrochemical cells it is
35 facile to provide relatively large electrical field gradients with only moderate potentials applied across the cell; under such conditions transport by electromigration will be fast. Typically ionic mobilities will be of the order $\sim 10^{-4} \text{ cm}^2\text{V}^{-1}\text{s}^{-1}$, or 1 $\mu\text{m/s}$ for a field gradient of 1

V/cm. It is not difficult to provide field gradients of 10-1000 V/cm in relatively thin ($\sim < 1\text{mm}$) electrochemical cells with the result that electromigration times across fluid or solid electrolyte layers of less than 1 second are readily accessible.

5 Regions for reaction or mixing may be considered as a channels or chambers of depth d and length l , where t is the transit time for fluid flowing along the length of a channel. Temperature changes can be related to the residence time t over which the processes causing heat generation or consumption occur, to the heat generation or consumption rates, to the thermal capacity of fluids and other materials in the device, and to the thermal time
10 constant for cooling processes which will be a function of thermal diffusivity, and dimensions such as distance across fluid and other layers to conductive heat sink structures. In order that close control be exercised over the temperatures within the material transport and reaction regions, it is should be ensured that thermal time constants associated with a region are low.

15

If any of the materials, such as the source materials, electrolytes, reagents, products or solvents are thermally labile then temperature rises should be limited. In any case the yields or rates of processes generating first and second products are likely to be temperature dependent and so control of temperature in the device is desirable. In general temperature
20 control is improved by maintaining short thermal transfer distances and is therefore readily improved in micro-engineered devices. The performance of the heat transfer process may generally be related to a dimensionless parameter of the form $\mu t/d^2$ where μ is thermal diffusivity, t is time allowed for heat transfer, and d is distance to a conductive heat sink surface. Where $\mu t/d^2 > \sim 1$ then thermal equilibrium has been largely achieved. Taking t in
25 $\mu t/d^2 = 1$ as a thermal time constant and rearranging gives $t = (d^2/\mu)$ and clearly this is decreased for small values of d . Some example values relating thermal diffusivities, conduction lengths and time constants are tabulated below.

These values indicate that for short thermal response times of less than one second, liquid
30 layer thickness should be 100 μm or less. For cases where energy transfer rates are low these constraints may not apply. In practice where a structure and its contents form a composite layer with different values of μ and d , the evaluation of the heat transfer characteristics is inevitably more complex but it is commonly adequate to identify the most thermally resistant layer and base design calculations on that. Where layers of reagent fluids
35 and solvent are involved, it will usually be adequate to ensure that those are sufficiently thin to avoid maintaining excessive temperature differences, and to contain them by more conductive structures, such as thin metal, glass, or ceramic constructions, linked to heat

sinks or sources such as heat exchangers, heat pipes, Peltier coolers, or resistive heaters.

On the micro scale smaller quantities of liquid are used and diffusional distances within the liquid are dramatically lowered allowing for rapid diffusion. The diffusion rate may be affected
5 by many different factors such as chemical kinetic factors and transport of dissolved material in the solvent by convective, advective, or diffusive processes. Within the microfabricated devices, the cross channel dimensions generally ensure that low Reynolds laminar flow conditions apply. Mixing and reaction of species from adjacent flow streams or for species to
10 cross the flow streams. Turbulent fluid transport is generally absent in devices of micro-engineered dimensions so that movement of species across flow streams proceeds by molecular migration mechanisms such as diffusion or electromigration. Where diffusive transfer is the limiting factor then the rate of diffusion is related to the length of the path through which the molecule diffuses and the geometry of the liquid body. Diffusive transfer
15 rates will generally be inversely related to the path length or square of the path length depending on whether the conditions for steady state or transient diffusion apply.

Diffusive transfer will be required where the species to be electrochemically transformed is uncharged, or does not travel through the field region, and also for uncharged species
20 involved in non electrochemical processes taking place at the electrode. Diffusive transfer is involved where the source material is not a charged species which can be brought by electromigration to the electrode for conversion, and diffusive transfer can still be controlling for charged species where other ionic species, as supporting electrolyte, carry most of the current and reduce field gradients. Further the precursor materials required to react with
25 primary product to generate secondary product will in general not be charged species. The length of time diffusively transferred source and precursor materials need to be resident adjacent to the working electrode can be estimated on the basis of diffusion processes where the distance to the electrode surface across a flow carrying such materials is taken as the characteristic distance for diffusion calculations. Although a full analysis of the diffusion
30 process can be complex, it is generally adequate to consider the diffusive process will be close to complete when the dimensionless parameter $Dt/d^2 \gg 1$. This corresponds to near equilibrium, or completion of the diffusive process. (D is diffusion coefficient, t is time allowed for mass transfer, and d is the distance across fluid to the surface (electrode) at which conversion takes place.). Values for residence time based on diffusion provide minimum
35 guide values as longer times may be required if reaction kinetics at the electrode surface are not sufficiently fast, and if other mass transfer process introduce delays e.g. dissolution of solid reactive products and their diffusive transfer from the surface.

Acceptable values for the reactor device dimensions and residence time within the electrochemical conversion stage will depend on the stability of the reactive product to be formed, and the desired throughput.

- 5 Typically diffusion coefficients (D) in non-viscous fluids for low to moderate molecular weight species of the size range of interest (Molecular weights of a few hundred of chemicals) will be in the range 10^{-5} to 10^{-7} cm^2s^{-1} . Taking a value for D of 5×10^{-6} cm^2s^{-1} , the approximate time t for diffusive transfer times across a path length (l) may be derived from expressions of the type $Dt/d^2 = 0.01$ to 1, where $Dt/d^2 = 0.01$ approximates to a diffusion front reaching a distance d from source plane, and $Dt/d^2 = 1$ corresponds to near completion of the diffusive process (concentration gradient across d being nearly eliminated). Approximate times t for reaching diffusive equilibration ($Dt/d^2 = 1$) at different path lengths (d), in which the dissolved material must travel, based on $d = 5 \times 10^{-6}$ or 5×10^{-7} cm^2s^{-1} are tabulated below in the table of diffusive mixing times:

15

d micrometers	D 10^{-6} cm^2s^{-1}	t seconds for $Dt/d^2 = 1$	D 10^{-6} cm^2s^{-1}	t seconds for $Dt/d^2 = 1$
1	5	0.002	0.5	0.02
3	5	0.018	0.5	0.18
10	5	0.2	0.5	2
30	5	1.8	0.5	18
60	5	7.2	0.5	72
100	5	20	0.5	200
300	5	180	0.5	1800
1000	5	2000	0.5	20000

- About 50% of the diffusive transfer will occur in about a tenth of the above times (corresponding to $Dt/d^2 \sim 0.1$). On the basis of the above table relatively rapid equilibration by diffusion alone will occur within 100 seconds where the required transport distance d is of the order of or less than 100 μm . The relevant distance d for the mixing of two fluid streams will be that from the furthest edge of the channel where the two fluids meet. For transfer of material to or from a surface, such as to a primary product deposit on an electrode, d is the distance across the fluid stream or layer to that surface. In micro-engineered devices where distance d is made small, the diffusion controlled transport, mixing, and reaction times are decreased and controlled by the distance d .

25

For processes operating under transport control, reactant consumption and product flux from the reaction zone of a device depends on the transit time for fluid flow through the reaction zone and on the time for completion of cross flow diffusive processes in that zone. Selecting flow rates so that reaction zone fluid flow transit times and cross flow diffusion completion times are similar will result in reaction flux per unit volume of device improving as distance d is decreased. This may result in greater heat fluxes from reaction and/or ohmic (Joule) heating but as thermal time constants similarly decrease with d the temperatures within the device do not rise excessively. Values of dimension d in the range 1000 to 50 μm correspond approximately to diffusion limited reaction fluxes equivalent to current density values of 0.001 to 1 Amp / cm^2 , an acceptable range for electrodes in micro-engineered devices. For devices with larger value for d the reaction flux rates will tend to be lower due to diffusion limitation and so production rates per unit device volume will be lower. It is an advantage therefore that the distance across channels or chambers for mixing or transfer of reagent to reactive deposits be low and this dimension in devices according to the present invention should be 10 to 3000 μm , and preferably in the range 30 to 300 μm .

Where mixing processes other than diffusive mixing are ineffective, the preferred approximate maximal distance across a channel, or chamber, in the direction which material is required to diffuse is 300 μm . Required residence time within a channel or chamber sufficient to allow diffusive mixing will depend on the value of that dimension. This dimension along with channel width determines the cross sectional area of the channel, and fluid throughput will depend on the cross sectional area and length of a channel or chamber and on the fluid flow speed. Although channel length may be quite extended, especially if drawn tubular structures are used in the construction. However where the channels or chambers are required to incorporate micro-engineered structures such as electrodes, and especially if they are to be rendered by conventional micro-engineering techniques on substantially planar substrates, it is desirable that overall lengths and widths be limited. Typically flow speeds readily achievable for liquids in micro-fluidic systems without excessive pressure drives range up to 10 cm/s, and are preferably in the range 0.01 to 1 cm/s. Appropriate lengths for channels or chambers in which diffusive processes are allowed to proceed to completion will range up to 10 cm, and preferably lie in the range 0.1 to 3 cm.

It is not necessary for the purposes of the present invention that laminar flow conditions are maintained for fluid flows within the device. Channels and chambers may be made large enough to support turbulent mixing with distances across channels of greater than 0.1 cm and more conventionally of 1 cm or greater generally being required. Where mixing is to be induced by simple flow of fluids through channels and chambers, the mixing and mass

transfer across flow will not be efficient at these dimensions. However efficient mixing may be induced by employing pulsed or reciprocating flows or by employing mechanical agitation of fluid by structures such as stirring paddles or magnetic stirring bars.

5 The dimensions in the mixer/reaction stages will be governed by the same sort of diffusion processes as indicated above for the electrochemical primary product generation stage and reaction with precursor to generate secondary product. Where two laminar streams run together, the diffusion distance d controlling mixing time will again be the channel depth. Where reaction is very fast and one stream has an excess of reagent then the rate limiting
10 diffusion distance will tend to reduce to that fraction of the channel width corresponding to fluid from the second stream. This will be the case for single and multiphase flows. For multiphase processes the limiting mass transfer distances and times may be altered somewhat, but if the phases are immiscible liquid it is likely that the total result will not change substantially, except as indicated above or if inter-phase transfer is kinetically
15 hindered. If one phase is gaseous then mass transfer limitations are likely to reside entirely in the liquid phase, and be set by the distances across that phase. Reactions may of course not be mass transport limited. Where kinetic limitations apply for single phase reactions it may be adequate to carry out partial or complete mixing in micro-engineered structures and then transfer the product to a holding container for process completion. For multiphase
20 processes the degree of subdivision of the phases and the interface geometry will depend critically on how the fluids are contained and moved.

The above indicates that for reaction times in the 0.1-10 second range, channel depths of ~10 - 1000 μm are indicated, and that preferably channel depth will be in the range 30 to 300
25 μm . The earlier table on diffusive mixing times indicated that if mixing and reaction in millisecond time scales are required for liquid reagents, then the channel depth would have to be ~1 μm . Total flow rates achievable under those conditions would be quite low (~1 cc/h or less for 1 cm wide channels). The table below shows values for fluid throughput and transit times for channels some example dimensions. The combinations of transit times and
30 diffusion distances correspond to significant to full diffusive mixing for species of moderate molecular weights. Limitations to channel length and therefore available transit times at any given flow rate will depend on the size of the structure that can conveniently be fabricated. Values for the required drive pressure for laminar flows in these channels are indicated in the table below.

Flow rate cc /hour (for 1 cm width)	Mean transit Time t sec	Channel height and Diffusion distance d micrometers	Channel transit length cm	Pressure drop bar (for viscosity 1 cPoise)
1	0.1	7	0.04	3.7E-03
10	0.1	7	0.39	3.7E-01
100	0.1	7	3.93	3.7E+01
1000	0.1	7	39.28	3.7E+03
1	1	22	0.12	3.7E-04
10	1	22	1.24	3.7E-02
100	1	22	12.42	3.7E+00
1000	1	22	124.22	3.7E+02
1	10	71	0.39	3.7E-05
10	10	71	3.92	3.7E-03
100	10	71	39.28	3.7E-01
1000	10	71	392.83	3.7E+01

It is clear for these short to moderate transit times that flow rates will generally need to be restricted to less than 100 cc/ hour if channel lengths or pressure drops are not to be excessive. These flow rates are for 1 cm width channels and relate linearly to channel width.

Multiphase reaction depends on being able to maintain a useful inter-phase contact area. This becomes more difficult as dimensions are reduced. While microcontactors and mesh structures of the type described previously (see International Patent Publication No WO 97/39814). may be applied where channel depths are 20 μm or greater, the balance between pressures required to drive flow and surface tension forces below that point would tend to produce slugging flow in the phases. Reaction may be maintained in slugging flow but slug dimensions will control rates and flow rates and recirculation induced within the slugs and not according to the diffusive processes appropriate to simple laminar flows.

15

The electrolysis cell may constitute a rechargeable and or demountable cartridge that can be removed to enable the primary product (e.g. a metal deposit) or source material to be replenished away from the process generating the secondary product (e.g. an

organometallic product), or alternatively, to enable the primary product (metal deposit) to be consumed in generating a secondary product (e.g. an organometallic product) away from site of the electrochemical process.

5 A fluid pumping means is preferably connected to the reactor device, including to the electrochemical cell where fluid electrolytes or sources of redox active materials are employed. Such fluid pumping means may, as appropriate to the selected fluids, include centrifugal pumps, diaphragm pumps, peristaltic pumps, electrosmotic flow generating structures, magnetohydrodynamic pumps, syringe pumps, and fluid reservoirs positioned to
10 maintain hydrodynamic heads to drive fluid flow. Valves and flow regulators may be included in fluid pathways leading to and from the device.

In the reactor devices described in Figures 1a to 17, the electrode 13 at which primary product is formed is termed "the working electrode" and is shown as being held at negative
15 potentials (i.e. cathodic) whilst the electrode 14 is held at a positive potential (anodic). This will be consistent with generation of alkali metals from their compounds and salts, but working electrodes may be held at whatever potential is consistent with the conversion of source material to primary product, and this may include positive potentials. The figures are generally represented as simple planar assemblies but other geometries including cylindrical
20 assemblies and stacked sheets may be employed.

Multiple anodes and cathodes and arrays of such electrodes may be employed, and devices may incorporate one or more reference electrodes allowing the potentials of other electrodes to be monitored or controlled.

25

Examples of types of chemistry that could be carried out in synthetic devices incorporating electrochemical cells according to this invention are described below to illustrate but not to limit the invention.

30 1 Formation of sodium, lithium, or potassium alkoxide or phenoxide.

Electrolysis is carried out in reactor devices of first or second types to produce lithium metal as the primary product. Solutions of lithium salts or Lithium ion solid or polymeric conductors may be used to provide ion conductive material and source material. Alkyl
35 halide in solution as precursor reactant is flowed up to contact lithium metal electrodeposited on a cathode to react with the lithium and form lithium alkyls that may

be carried away in solution by a solvent. Stages in the chemistry are represented below. The process may be applied to other organohalide precursor materials such as sodium or potassium or lithium as long as sodium/lithium/potassium does not directly attack parts or other substituents of the organic group. This process is shown below.

5



where Y⁻ is an anion such as CF₃CO₂⁻

10

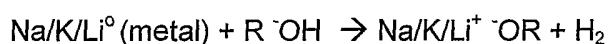

where R = C₁H₃, C₂H₅, C₃H₇, C₄H₉, Ph, substituted Ph, or heteroaryl, or substituted heteroaryl,

15

With lithium precursors, solubility of side product lithium halides may be an issue. Lithium bromide and iodide are relatively soluble in many organic solvents, may not interfere with subsequent reactions of lithium alkyls, and organo-iodides and bromides are therefore the preferred precursor reactants. It is preferable to ensure that excess Li metal is available to avoid consumption of lithium alkyl produced by further reaction with precursor (R-X + Li-R → Li⁺X⁻ + R-R), and this may be achieved by carrying out an initial electrode charging process to build up a Li⁰ deposit or by employing discontinuous mode operation. Lithium salt electrolysis and lithium alkyl formation may be carried out in ether solvents allowing continuous operation of devices of the first type, but discontinuous operation and devices of the second type may also be employed.

25

The sodium, potassium or Lithium alkyl produced may be carried by fluid flow to a mixer stage to carry out a wide range of chemistries established for those reagents.

30 2

Sodium Naphthalenide formation.

Electrolysis depositing sodium metal may be combined with a flow of naphthalene solution to generate the sodium naphthalenide product that may be used subsequently as a reagent. This process does not involve generation of low solubility halides or problems with reaction of product and precursor (naphthalene). Devices of the second

type based on sodium beta alumina as ion conductor are suitable. The overall reaction may be written as:

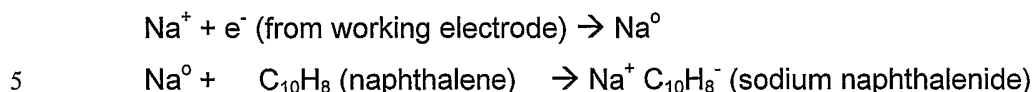

Sodium naphthalenide appears to exist as Na^+ associated with a radical anion. Similar reagent are derived from anthracene (hence sodium anthracenide), and others related to aromatic precursors. Similar reagents may be derived from lithium and other electropositive metals.

Similarly potassium naphthalenide may be synthesised using potassium as the source material, and naphthalene as the precursor. Also sodium naphthalenide can be synthesised using sodium as the source material and naphthalene as the precursor.

15

3 Synthesis of sodium /potassium/lithium anthracenides.

The present invention can be used for the synthesis of sodium anthracenide, potassium anthracenide, or lithium anthracenide by using sodium, potassium, or lithium as the source material and anthracene as the precursor.

20

4 Synthesis of sodium/potassium/lithium phenanthrenides.

The present invention can be used to synthesise sodium phenanthrenide, or potassium phenanthrenide or lithium phenanthrenide by using sodium, or potassium or lithium as the source material and phenanthrene as the precursor.

25

5 Conversion of organo tin compounds.

An example reaction would be of the type below:

30

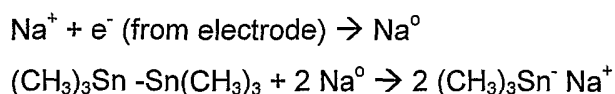

35

The sodium compound can then be reacted at a later mixer/reactor stage e.g. with organo-halides to add a further organic group to the tin.

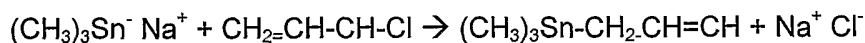

6 Generation of sodium /potassium/lithium alkoxides or phenoxides.

5 Sodium alkoxides or potassium alkoxides or lithium alkoxides can be synthesised using the present invention. In accordance with the following process

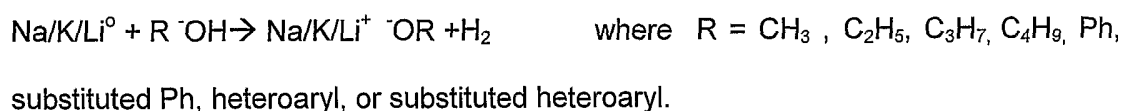

10

Sodium ethoxide and other alkoxides which could be similarly produced e.g. isopropoxide, are widely used in chemical synthesis. Hydrogen gas evolved during synthesis will generally not interfere with other reactions but may cause unwanted flow disturbance in the device. Mixtures of alkoxides and salts may be produced from esters without hydrogen evolution.

15

7 Removal of halides from aromatics by sodium metal.

20

Halides can be removed from aromatics using the present invention in accordance with the following process

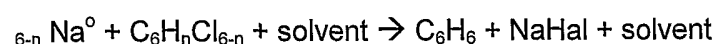

where Hal = Cl, Br, or I.

For example, $\text{Na} + \text{C}_6\text{H}_n\text{Cl}_{6-n} + \text{sodium metal} + (\text{proton source solvent, e.g. alcohol}) \rightarrow$

25

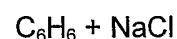

The addition of a proton source may need to be spatially separated by adding it at a mixer stage following the reaction of aromatic halide with the electro deposited sodium metal.

30

8 Birch reduction

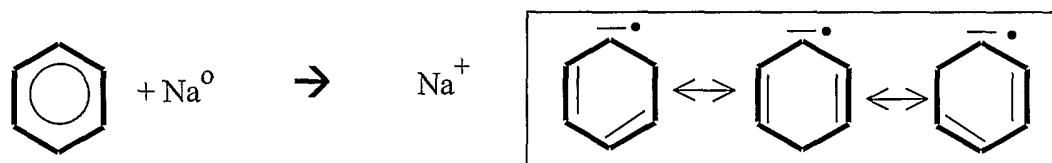

Reactions of this type may be possible in type devices of the second type with solid sodium ion conductor if compatibility with the solvent can be established, or alternatively sodium salts soluble in liquid ammonia could be used as electrolyte and source material in devices of the first type.

An example is :-

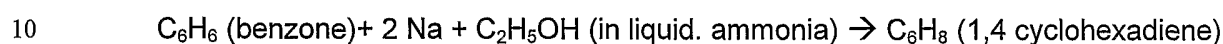

The reaction goes via radical anion that abstracts protons from alcohol.

9 Generation of Grignard reagents.

15

The overall reaction is:

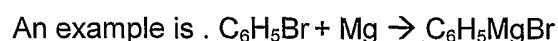
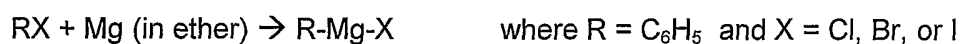

The reaction is carried out in ether solvents, and solvents such as ethers facilitate the reaction in that they co-ordinate Mg and stabilise the reagent. While electrolytic deposition of Mg^0 from organic solutions is possible, it may also be produced by reduction of dissolved magnesium compound by alkali metal such as sodium which may therefore be employed as the primary product as indicated for other reaction sequences.

25

Similarly for making organometallic reagents for metals whose ions are not mobile within reasonably conductive solid phases, e.g. metals with multiply-charged ions such as Mg, Zn, Cd, Sn, Al, the preferred method will be to provide those metals in solution

and either directly electro-deposit or carry out a conversion using electro-deposited alkali metal in devices of either first or second type.

10 Generation of halogenated products.

5

This could include generation of products containing fluorine, chlorine, bromine or iodine. The primary product may be elemental halogen such as chlorine produced by electrochemical oxidation of a soluble halide.

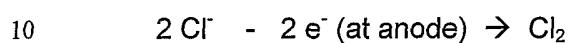

The chlorine may react with a range of organic species to produce direct chlorination products by addition (to unsaturated bonds) or substitution. Alternatively the chlorine may be converted to an inorganic reactive intermediate. For example PCl_3 and PCl_5 may be formed as secondary products by reaction of chlorine with phosphorus which may be supplied suspended or dissolved in a fluid stream. These secondary products may be reacted within the device with further reagents such as carboxylic acids to generate products such as acyl chlorides.

20 11 Generation of ylids from phosphonium salt cations by the Wittig reaction and reaction of ylid and aldehyde to generate alkenes. For example:

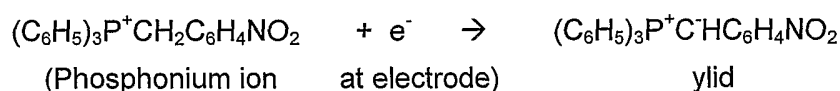

25

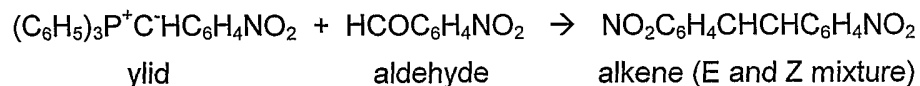

30 It will be appreciated that the cartridge and methods described above may be performed on the macro scale but especially may be applied on the micro scale by generating microfabricated cartridges or systems.

In this disclosure, the term "fluid" means a gas or supercritical liquid or either an aqueous or non-aqueous liquid. Preferably the fluids are liquids. Preferably a fluid containing salt or other redox active compounds of the metal to be electrodeposited is ionically conductive but

35

may be non conductive provided an ionically conductive material is provided to link the working and counter electrodes.

5 Additional mixing elements may be added to the reactor device if needed, such as, for example small vanes or deflectors that are shaped and positioned in the chamber and/or the inlet to, or outlet from, the chamber to cause the fluid to swirl or mix.

10 A number of chemistries may be considered for operation in the reactor devices described, but the generation of alkali metals electrochemically and their reaction with organic reagents to form organometallic reagents such as sodium naphthalenide or lithium alkyls are preferred.

15 Therefore such a reactor device may find use on the laboratory bench of a synthetic chemist and be scaled up or scaled out by use of multiple or array devices for manufacture methods. For example the output conduit of a first reactor of the present invention may be connected in flow series to an inlet conduit of another reactor constructed in accordance with the present invention.

20 Similarly, a plurality of series connected reactors may be provided on a common structure. One or more arrays of series connected reactors may be arranged relative to another one or more arrays of series connected reactors on a common structure. This concept is not unlike that of a components built on an integrated circuit chip but in this case the components are micro-engineered reactors.

25 Importantly reactor devices according to the invention may be applied in the conversion of dangerous waste chemicals and solvents into less dangerous forms, especially but not limited to the conversion and clean up of halogenated products such as PCBs (polychlorinated biphenyls) and CFCs (chlorinated fluorocarbons). Such conversions may proceed by direct reaction of primary product metal such as sodium with the chemical to be converted, or by generation of a secondary product such as sodium naphthalenide that is then mixed and reacted with the chemical to be converted. The use of sodium naphthalenide as a decomposition/clean-up reagent for PCBs has been reported, as has reactive dehalogenation of CFCs by sodium metal. These wastes may be subjected to direct treatment in devices according the present invention with electrochemically generated alkali metal (e.g. sodium) or by means of cartridges with electrochemically generated alkali metal according to the present invention.

35

CLAIMS

- 1 A micro-engineered reactor for performing chemical synthesis, said reactor comprising
- 5 (a) a reaction chamber and an electrochemical cell in close communication with the interior of the reaction chamber;
- (b) said reaction chamber being of micro-engineered dimensions and having micro-engineered inlet and outlet conduits for conveying fluids to, and from, the reaction chamber;
- 10 (c) said cell comprising at least two electrodes positioned and arranged relative to each other to define a space between them, which, in at least one mode of use of the cell, receives an ionically conductive fluid that is, or contains, a redox-active source material, and forms an electrically conductive path between the electrodes through which an electrical current passes when an electrical potential is applied to
- 15 the electrodes so as to electrolyse the source material and form a primary product at, or adjacent to, a surface of an electrode within the interior of the reaction chamber;
- (d) means for introducing into the reaction chamber a precursor material that will react with the primary product to produce a secondary product, and
- 20 (e) means for conveying the secondary product away from the reaction chamber through said outlet conduit.
- 2 A reactor according to claim 1 wherein at least one of the electrodes has a surface at which, in use, the primary product is formed, and the surface is located within, or forms
- 25 a part of a boundary wall of, the reaction chamber.
- 3 A reactor according to any one of the preceding claims wherein at least one of the

electrodes has a surface at which, in use, the primary product is formed, made of, or coated with, a sacrificial material that will react with the source material to form the primary product,

5 4 A reactor according to claim 3 wherein the cell further includes an electro-depositing means for selectively applying an electrical charge to each of the electrodes in the presence of an ionically conductive fluid that contains ions of the sacrificial material, thereby to cause the sacrificial material to be deposited on the electrode or electrodes and replenish the sacrificial material that is consumed by the electrolysis.

10

5 A reactor according to claim 3 or claim 4 wherein the electro-depositing means is operable to deposit the sacrificial material on the surface of the respective electrode or electrodes prior to, or during reaction of the sacrificial material with the source material to form the primary product.

15

6 A reactor according to claim 4 or claim 5 wherein the electro-depositing means is operable to deposit the sacrificial material on the surface of the respective electrode or electrodes prior to, or during reaction of the sacrificial material with the source material to form the primary product.

20

7 A reactor according to any one of claims 4 to 6 wherein the electro-depositing means comprises means for applying a negative charge to one of the electrodes and a positive charge to the other electrode, and a fluid supply means is provided for introducing a source of an organic fluid containing a salt in which a cation is the
25 sacrificial material to be deposited on the negatively charged electrode, and a means is provided for generating an electrical field between the two electrodes so as to cause

electro-deposition of the material on to the surface of the negatively charged electrode.

- 8 A reactor according to any one of claims 4 to 6 wherein the electro-depositing means comprises means for applying a negative charge to one of the electrodes and a positive charge to the other electrode, and a fluid supply means is provided for introducing a source of an organic fluid containing a salt in which an anion is the sacrificial material to be deposited on the positively charged electrode, and a means is provided for generating an electrical field between the two electrodes so as to cause electro-deposition of the material on to the surface of the positively charged electrode.
- 10
- 9 A reactor according to claim 7 or claim 8 wherein the organic fluid that contains the ions of the sacrificial material is also the organic reagent that will react with the deposited material to produce the primary product.
- 15 10 A reactor according to any one of claims 7 to 9 wherein the organic fluid that contains the ions of the sacrificial material is also the precursor that will react with the deposited material to produce the secondary product.
- 20 11 A reactor according to any one of the preceding claims wherein at least one of the electrodes is made of a fluid permeable material and defines a part of the boundary wall of the reaction chamber through which a fluid source material permeates to react at a surface of the fluid permeable electrode that is in communication with the interior of the reaction chamber to form the primary product.
- 25 12 A reactor according to claim 11 wherein a second chamber is formed on a side of the fluid permeable electrode that is remote from the interior of the reaction chamber, and

an electrode of the cell is located in the second chamber, said fluid permeable electrode being made of a material that allows a primary product created by electrolysis of a source material within the second chamber to permeate through the permeable electrode into the interior of the reaction chamber and to react with the precursor material to form the secondary product.

5

13 A reactor according to claim 11 wherein the second chamber has an inlet conduit for the supply of fluid containing fresh source material to the second chamber and an outlet for removal from the second chamber of fluids depleted of said source material.

10

14 A reactor according to any one of claims 11 to 13 wherein a fluid permeable ionic or electronic conductor is provided between the electrodes so as to define a first region on one side of the conductor where an ion conductive solution is retained in contact with the one of the electrodes, and a second region on the other side of the said conductor, where an ion conductive layer, which may be fluid, solid, or semi-solid, is in contact with the fluid permeable electrode.

15

15 A reactor according to claim 14 wherein the conductor is mercury or an amalgam.

20 16 A reactor according to any one of the preceding claims wherein the cell is a rechargeable cartridge.

17 A reactor according to any one of the preceding claims wherein there is provided a fluid pumping means connected to the reactor for pumping the fluids through the reactor.

25

- 18 A reactor according to any one of the preceding claims wherein the source material and the precursor are present in a common fluid.
- 19 A reactor according to any one of claims 1 to 17 wherein the source material is present
5 in a first fluid and the precursor is present in a second fluid.
- 20 A reactor according to any one of the preceding claims wherein the outlet conduit of the reaction chamber is divided into two or more discrete outlet paths.
- 10 21 A reactor according to claim 20 wherein at least one or more discrete outlet paths are connected to an inlet conduit of another reactor constructed in accordance with any one of claims 1 to 20.
- 15 22 A reactor according to claim 20 or claim 21 wherein one of the electrodes of the cell is located in, or forms part of, the wall of the reaction chamber and one of the electrodes of the cell is located in or forms part of the wall of a conduit defining one of the discrete outlet paths.
- 20 23 A reactor according to any one of the preceding claims wherein the reaction chamber is constructed, dimensioned and arranged to define a plurality of adjacent flow paths through the reaction chamber via respective pairs of an inlet conduit and an outlet conduit.
- 25 24 A reactor according to any one of the preceding claims wherein there is provided an ion permeable barrier located between an anode and a cathode of the cell so as to define an anodic compartment adjacent the anode on one side of the ion permeable

barrier and a cathodic compartment adjacent the cathode on the other side of the ion permeable barrier.

25 A reactor according to claim 24 wherein the barrier is selected from the following
5 materials, namely a porous or permeable sheet, a dialysis membrane, an ion exchange membrane, a region of gelled electrolyte or a region of immobilised electrolyte.

26 A reactor according to any one of the preceding claims wherein at least one of the electrodes is a porous block through which fluids may flow.

10

27 A reactor according to any one of the preceding claims wherein there is provided a first discrete inlet conduit for supplying the source material, a second discrete inlet conduit for supplying the precursor, and a third discrete conduit for supplying a flushing fluid for removing the secondary product from the reaction chamber.

15

28 A reactor according to claim 27 wherein valve means are provided for selectively opening and closing each of the first, second or third inlet conduits.

20

29 A reactor according to any one of the preceding claims wherein one or more reference electrodes means is provided in the reaction chamber or cell for monitoring and controlling the electrical potential applied to the electrodes of the cell.

30 A reactor according to claim 29 wherein one or more monitoring electrode means is provided for monitoring the composition of the products produced in the reactor.

25

31 A reactor according to any one of the preceding claims wherein there is provided

within, or adjacent to, the reaction chamber, a heat exchanger for controlling the temperature of at least a region of the interior of the reaction chamber.

32 A reactor according to any one of the preceding claims wherein the output conduit is
5 connected in flow series to an inlet conduit of another reactor constructed in accordance with any one of the preceding claims.

33 A reactor according to claim 32 wherein a plurality of series connected reactors are
10 provided on a common structure.

34 A reactor according to claim 32 or claim 33 wherein one or more arrays of series
connected reactors are arranged relative to another one or more arrays of series
connected reactors on a common structure.

15 35 A method of performing chemical synthesis comprising the steps of:

- (a) providing a reactor constructed in accordance with any one of claims 1 to 34
- (b) presenting a source material to the space between at least two electrodes;
- (c) electrolysing the source material to form a primary product at, or adjacent to,
20 a surface of the electrode that communicates with the interior of the reaction chamber; and,
- (d) contacting the primary product in the reaction chamber with a precursor that will react and/or mix with the primary product to produce a secondary product.

25 36 A method according to claim 35 including the step of removing the secondary product from the reaction chamber.

37 A method according to claim 36 including the step of reacting the secondary product with a material that is a precursor for use in a further reaction, or a series of further reactions, to produce a final product.

5

38 A method for preparing a synthetic organic compound comprising the steps of:

- (a) providing a micro-engineered reactor constructed in accordance with any one of claims 1 to 34 wherein at least one of the electrodes is made of, or coated with, a sacrificial material that will react with the precursor to form the secondary product;
- 10
- (b) presenting a source material to at least the electrode that consists of, or has deposited thereon, the sacrificial material;
- (c) electrolysing the source material and allowing the electrolysed source material to react with the sacrificial material to form the primary product at, or adjacent to a surface of the electrode; and,
- 15
- (d) contacting the primary product in the reaction chamber with a precursor that will react with the primary product to form the said organic compound.

39 A method for preparing a synthetic organic compound comprising the steps of:

- 20 (a) providing a micro-engineered reactor constructed in accordance with any one of claims 1 to 35 wherein at least one of the electrodes is made of, or coated with, a sacrificial material that will react with the precursor to form the secondary product;
- (b) presenting an organic source material to at least the electrode that consists of, or has deposited thereon, the sacrificial product;
- 25 (c) electrolysing the source material and allowing the source material to react with the sacrificial material to form the secondary product at, or adjacent to a surface of the

electrode; and,

(d) contacting the primary product in the reaction chamber with a precursor that will react with the primary product to form the said organic compound.

5 40. A method according to claim 38 or claim 39 further including the step of replenishing the consumed sacrificial material by electro depositing material on at least one of the electrodes.

10 41. A method according to claim 40 wherein the sacrificial material is deposited on the respective electrode or electrodes by connecting the electrodes to an electrical supply whereby one of the electrodes forms a cathode and the other forms an anode, and the method includes the steps of presenting to the cathode, a fluid containing a salt in which a cation is the sacrificial material, and applying an electrical field between the cathode and an anode thereby to deposit the sacrificial material on the cathode.

15

42. A method according to claim 40 wherein the sacrificial material is deposited on a surface of the respective electrode by connecting the substrate to an electrical supply whereby one of the electrodes forms a cathode and the other forms an anode, and the method includes the steps of presenting to the anode, an ionically conductive fluid
20 containing a salt in which an anion is the sacrificial material, and applying an electrical field between the cathode and an anode thereby to deposit the sacrificial material on the anode.

25 43. A method according to claim 41 or claim 42 wherein a fluid containing the salt is presented to the electrodes whilst simultaneously applying an electrical charge to the electrodes thereby to deposit the sacrificial material onto at least one electrode, and

the source material is subsequently presented to the electrodes and allowed to react electrolytically with the sacrificial material to form the primary product

44. A method according to claim 41 or claim 42 wherein a fluid containing the salt is presented to the electrodes whilst simultaneously applying an electrical charge to the cathode thereby to deposit the sacrificial material onto at least one electrode, and the source material is presented to the electrodes simultaneously with the salt, and allowed to react with the deposited sacrificial material to form the primary product.
45. A method according to claim 35 wherein the reactor is constructed in accordance with any one of claims 12 to 15 and said method includes steps of:
- (a) introducing into the second chamber a fluid containing said source material; and
 - (b) electrolysing said source material in said second chamber so as to produce said primary product at a surface of the fluid permeable electrode that is in communication with the interior of the reaction chamber.
46. A method according to any one of claims 35 to 45 for the synthesis of lithium, or sodium, or potassium alkyls wherein the source material is derived from solutions of lithium, or sodium, or potassium salts, or solid or polymeric ion conductors thereof, and the precursor is an alkyl halide that reacts with the source material to form lithium, or sodium, or potassium alkyls as the secondary product.
47. A method according to any one of claims 35 to 45 for the synthesis of Sodium Naphthalenide wherein the source material is sodium, the precursor is naphthalene and the secondary product is sodium Naphthalenide.

48. A method according to any one of claims 35 to 45 for the synthesis of potassium Naphthalenide wherein the source material is potassium, the precursor is naphthalene and the secondary product is potassium Naphthalenide.
- 5 49. A method according to any one of claims 35 to 45 for the synthesis of Sodium anthracenide wherein the source material is sodium, the precursor is anthracene and the secondary product is sodium anthracenide.
- 10 50. A method according to any one of claims 35 to 45 for the synthesis of potassium anthracenide wherein the source material is potassium, the precursor is anthracene and the secondary product is potassium anthracenide
- 15 51. A method according to any one of claims 35 to 45 for the synthesis of Sodium phenanthrenide wherein the source material is sodium, the precursor is phenanthrene and the secondary product is sodium phenanthrenide
- 20 52. A method according to any one of claims 35 to 45 for the synthesis of Potassium phenanthrenide wherein the source material is potassium, the precursor is phenanthrene and the secondary product is potassium phenanthrenide
- 25 53. A method according to any one of claims 35 to 45 for the conversion of organotin compounds wherein the source material is sodium, the precursor is an organotin compound.
54. A method according to claim 53 for carrying out the conversion of organotin compounds by a reaction of the type

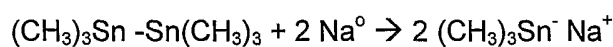
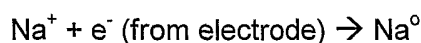

55. A method according to claim 54 wherein the sodium compound is further reacted with
5 an organo halide in accordance with the following formula:

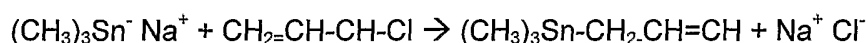

- 56 A method according to any one of claims 35 to 45 for the generation of sodium, lithium
or potassium alkoxide or phenoxide in accordance with formula

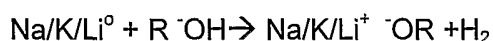
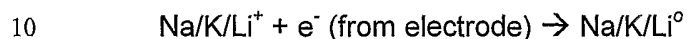

where R = CH₃, C₂H₅, C₃H₇, C₄H₉, Ph, substituted Ph, heteroaryl, or substituted
heteroaryl

- 15 57 A method according to any one of claims 35 to 45 for the removal of halides from
aromatics by sodium metal in accordance with the reaction

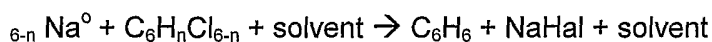

- 20 where Hal = Cl, Br, or I

- 58 A method according to any one of claims 35 to 45 for carrying out a Birch Reduction of
compounds in accordance with the reaction:

25

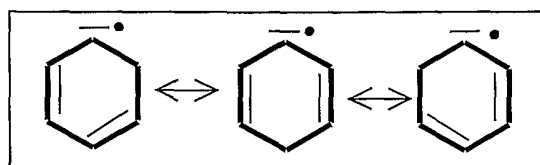
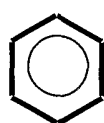

$C_6 H_6$ (benzene) + 2Na + $C_2 H_5 OH$ (in liquid ammonia) \rightarrow $C_6 H_8$ (1,4 cyclohexadiene).

59 A method according to any one of claims 35 to 45 for the generation of Grignard reagents in accordance with the reaction:

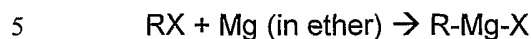

where $R = C_6H_5$, and $X = Cl, Br, \text{ or } I$

60 A method according to claim 59 wherein the reaction is:

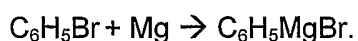

10

61 A method according to any one of claims 35 to 45 for the generation of halogenated products wherein the source material is a soluble halide, the primary product is a halogen produced by the electrochemical oxidation of the soluble halide, and the halogen is reacted with an organic precursor to produce a secondary halogenated product by addition to unsaturated bonds or by substitution.

15

62 A method according to any one of claims 35 to 45 for the generation of halogenated products wherein the source material is a soluble halide, the primary product is a halogen produced by the electrochemical oxidation of the soluble halide, and the halogen is reacted with an inorganic precursor to produce an inorganic reactive intermediate.

20

63 A method according to claim 61 or claim 62 wherein the halogen is chlorine, the inorganic precursor is phosphorus, and the secondary product is PCl_3 or PCl_5 .

25

64 A method according to any one of claims 61 to 63 wherein the secondary product is reacted in the reaction chamber with a carboxylic acid to generate acyl chloride products.

5 65 A method according to any one of claims 35 to 45 for the generation of ylids from phosphonium salt cations by the Wittig reaction and the reaction of ylids and aldehyde to generate alkenes in accordance with the formulae :

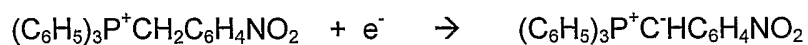

1/9

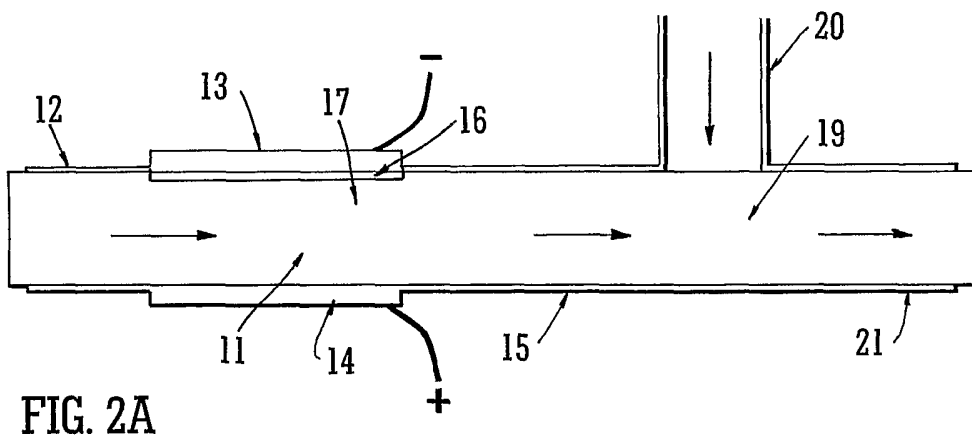
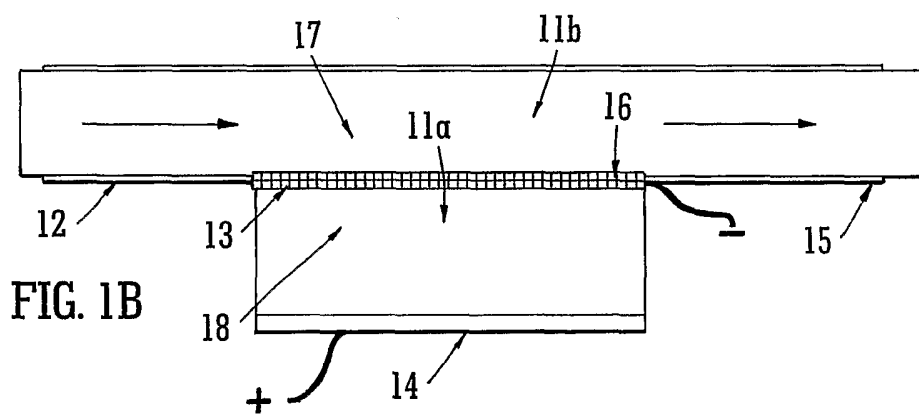
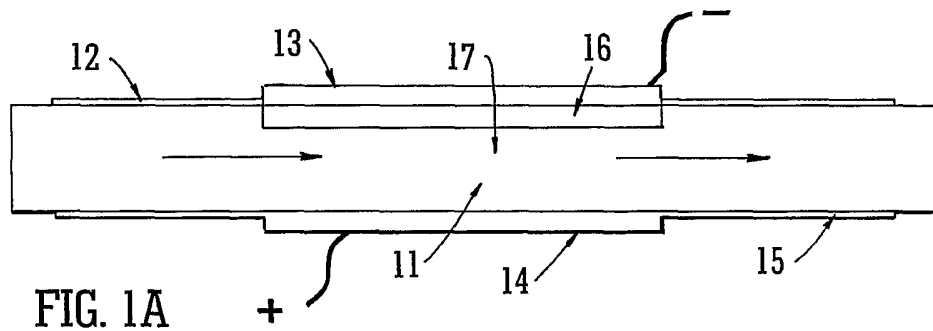

2/9

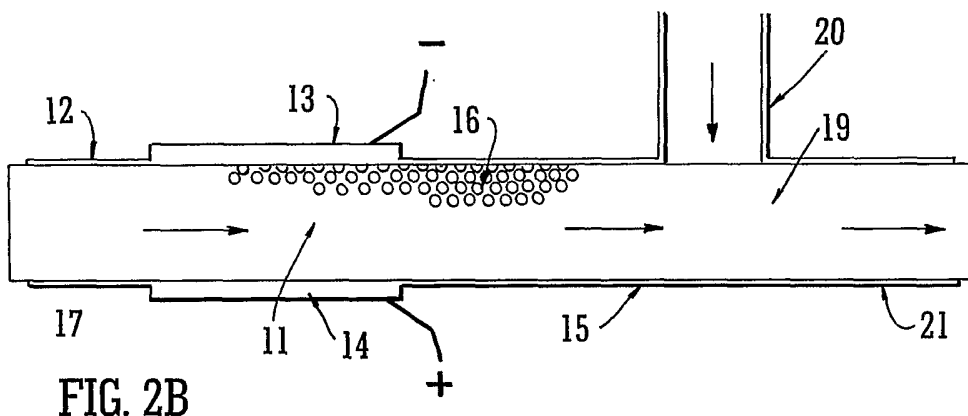

FIG. 2B

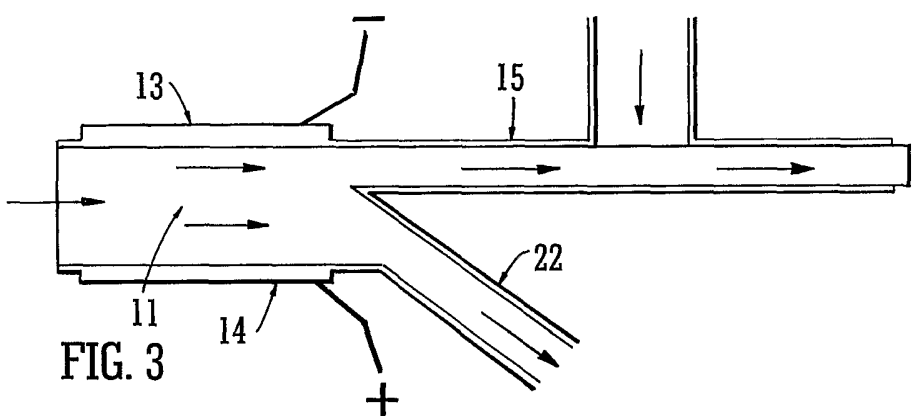

FIG. 3

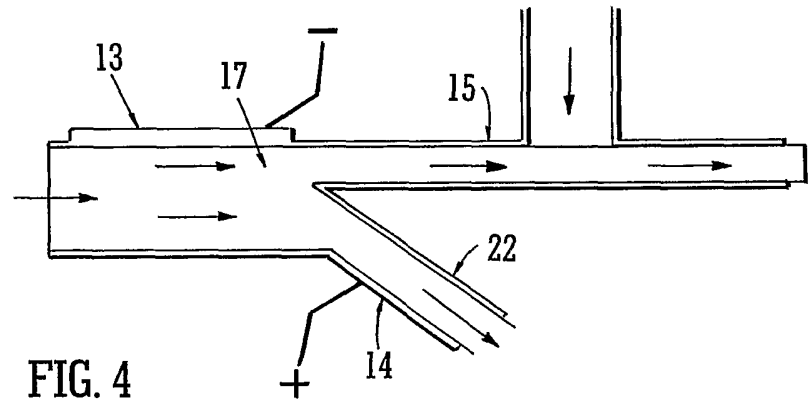
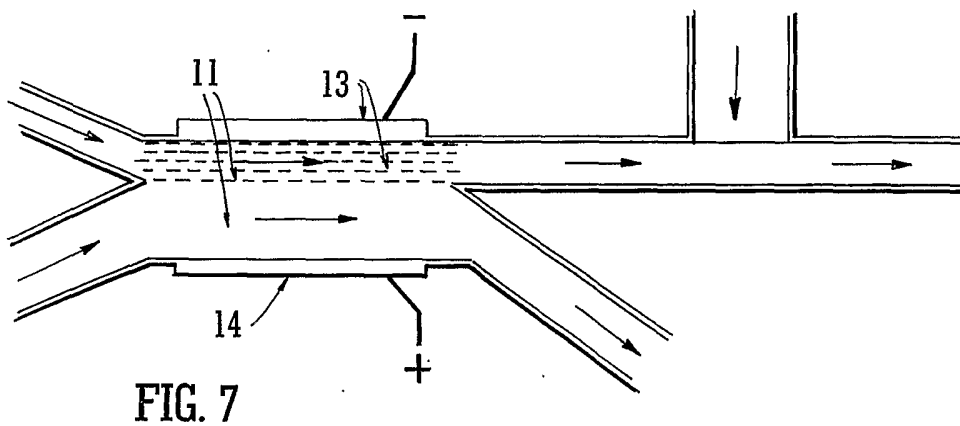
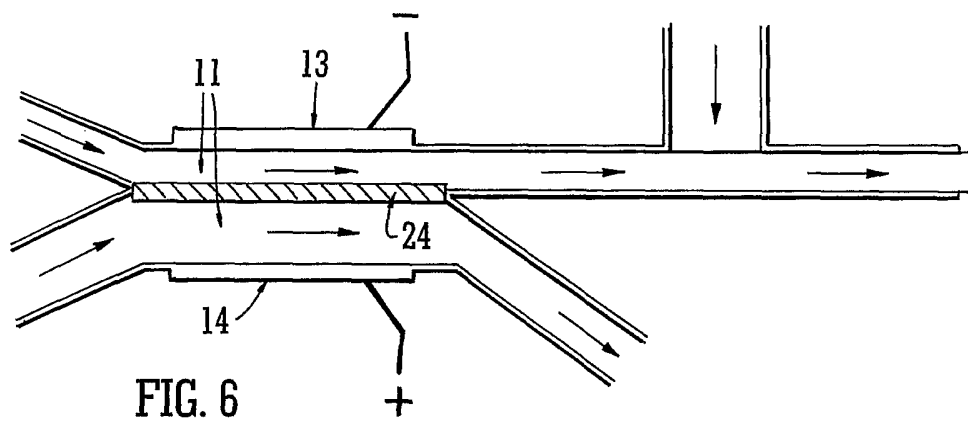
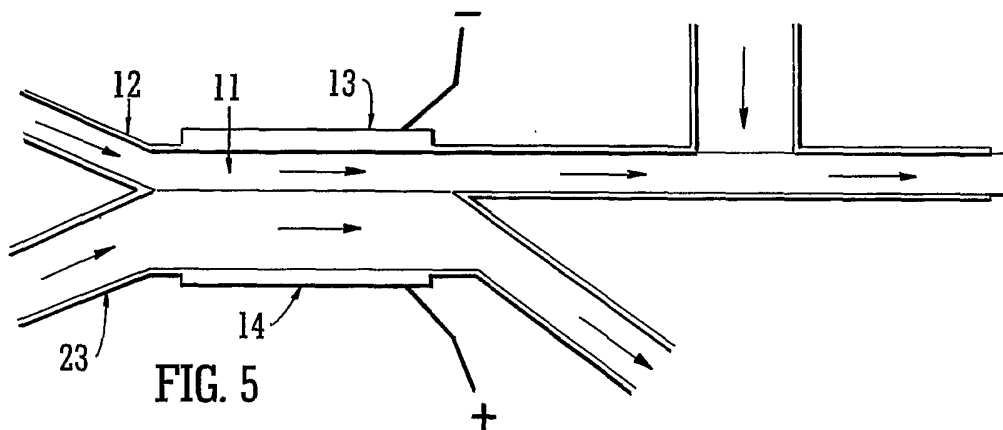
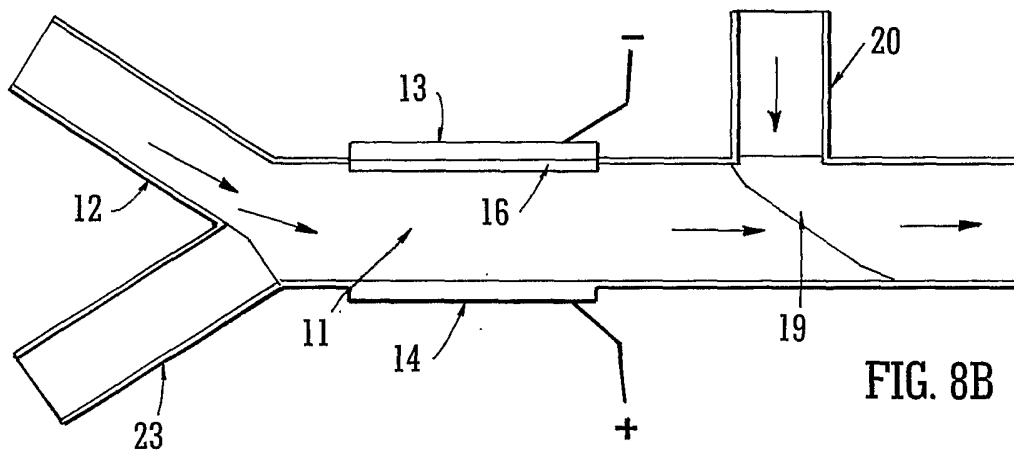
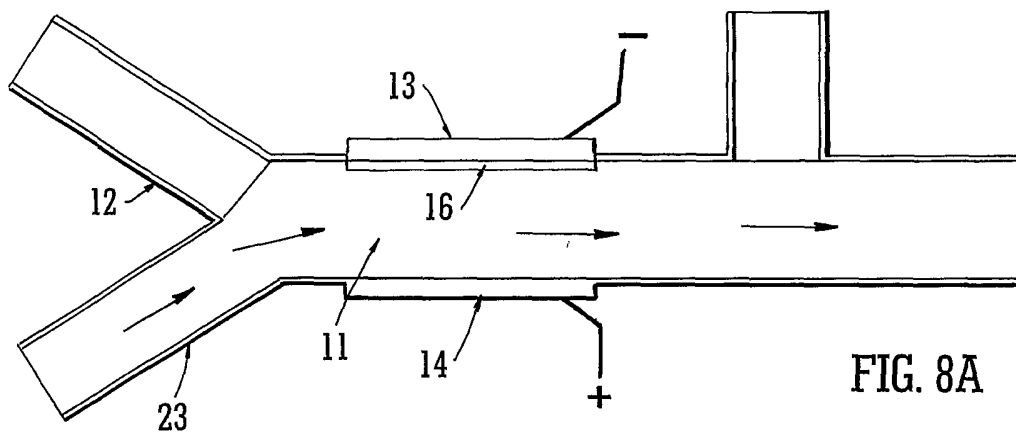

FIG. 4





5/9

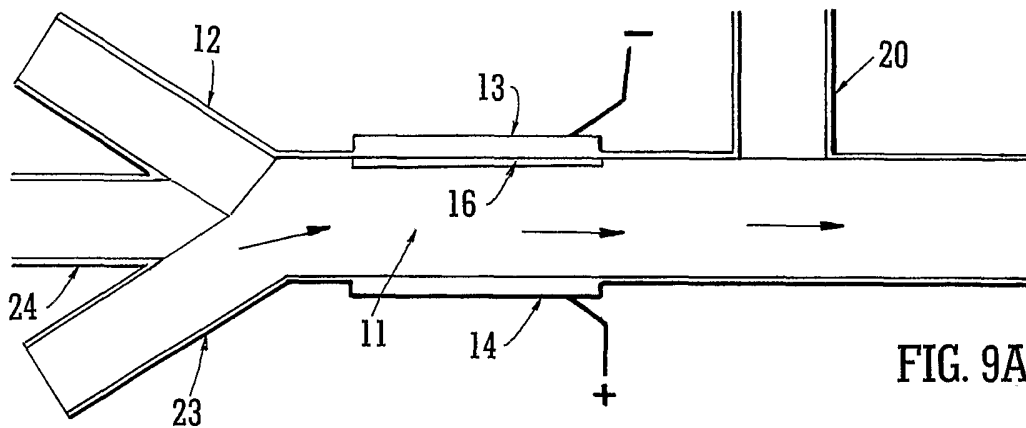

FIG. 9A

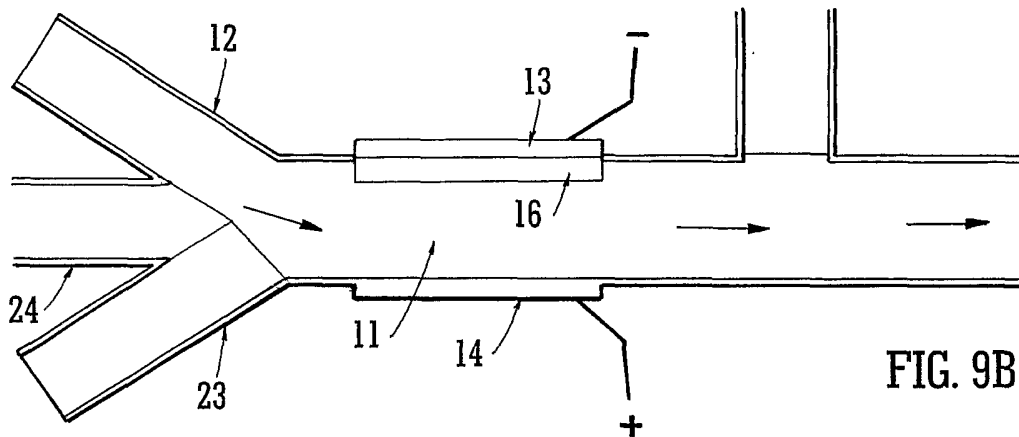

FIG. 9B

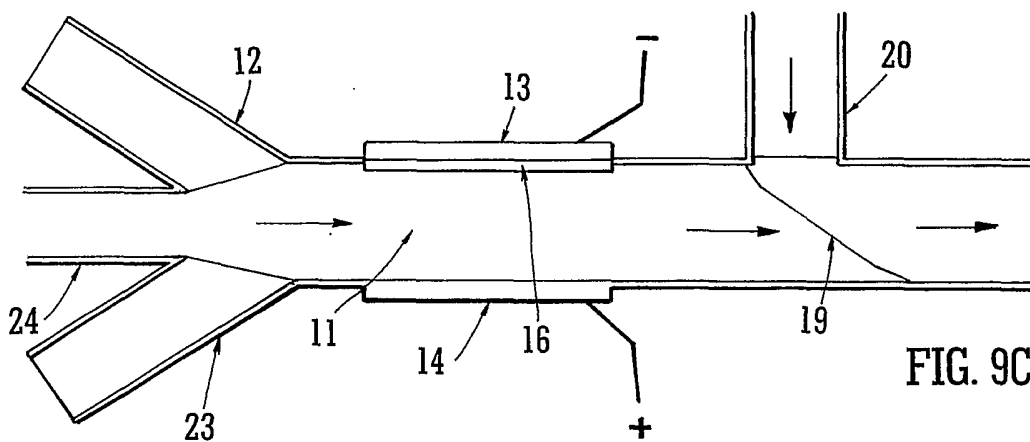

FIG. 9C

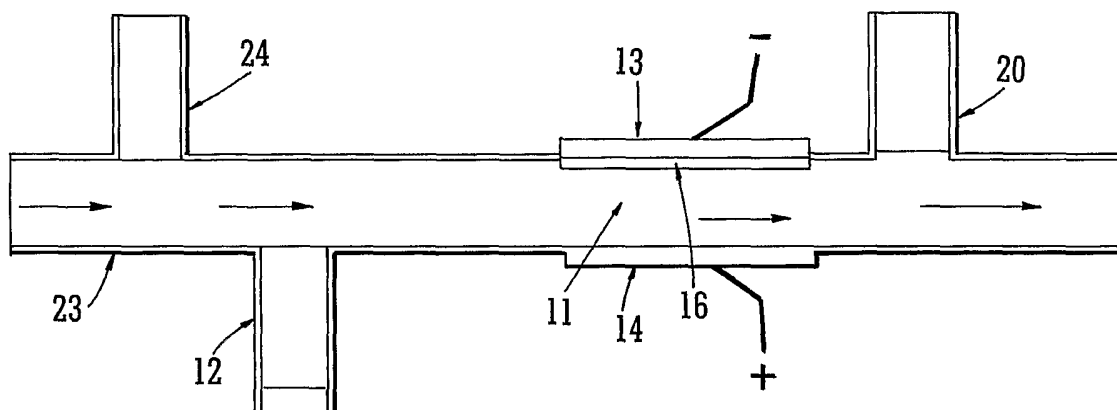

FIG. 10

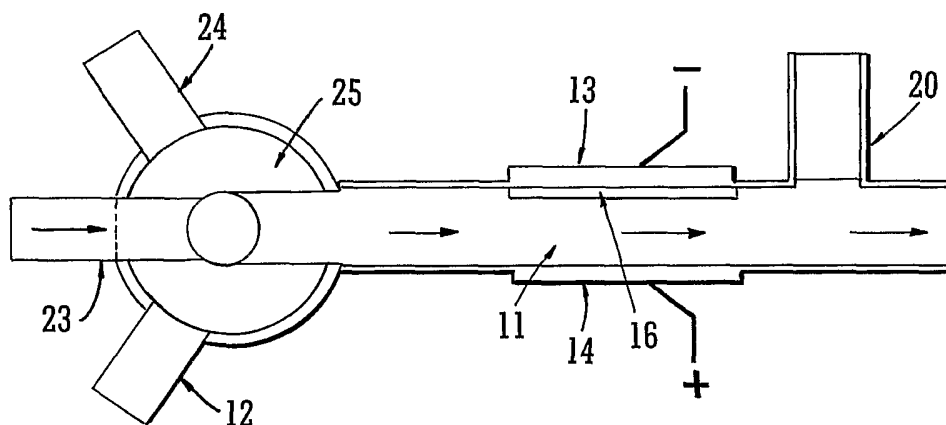

FIG. 11

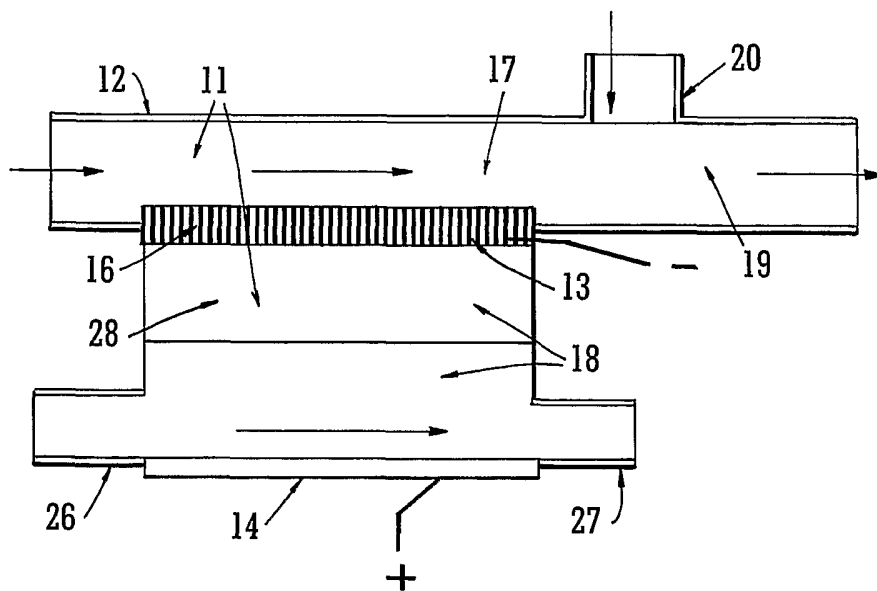

FIG. 12

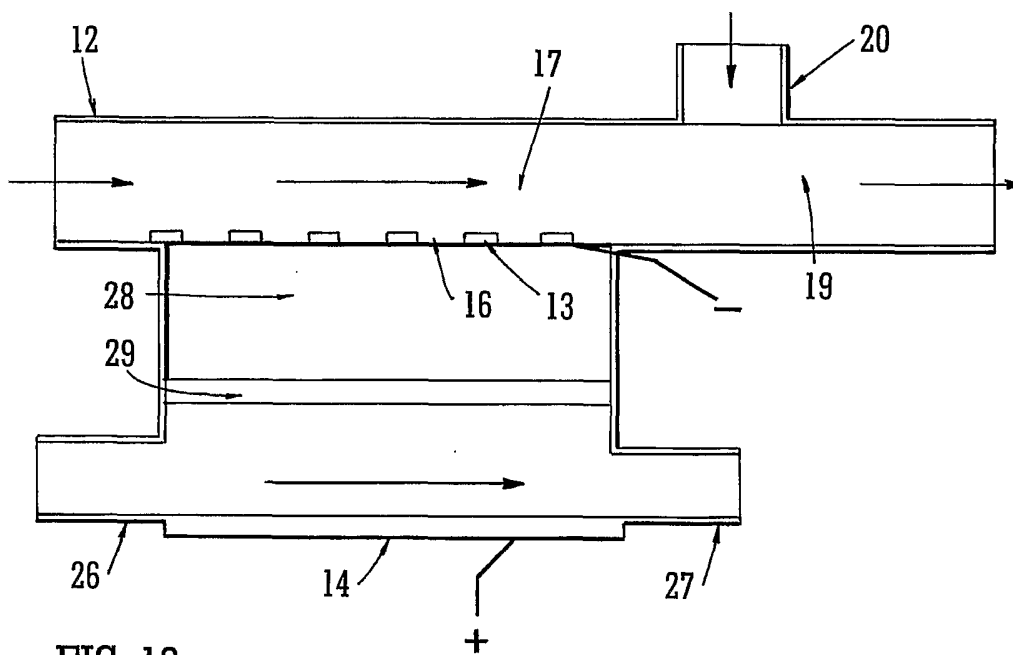

FIG. 13

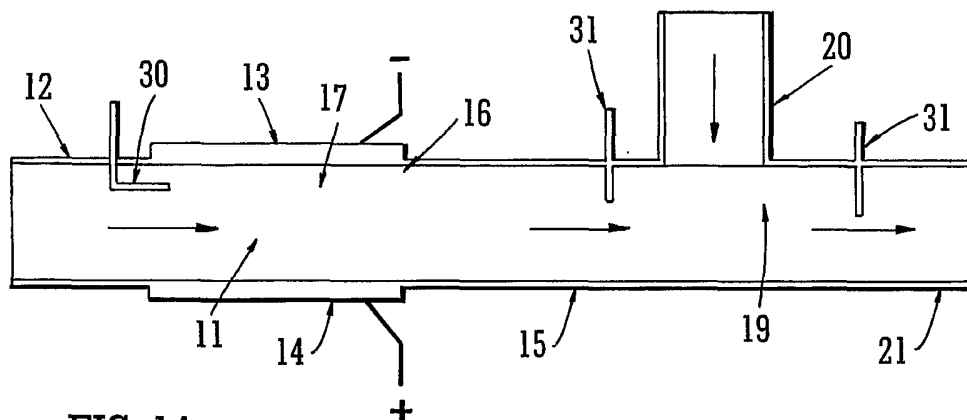

FIG. 14

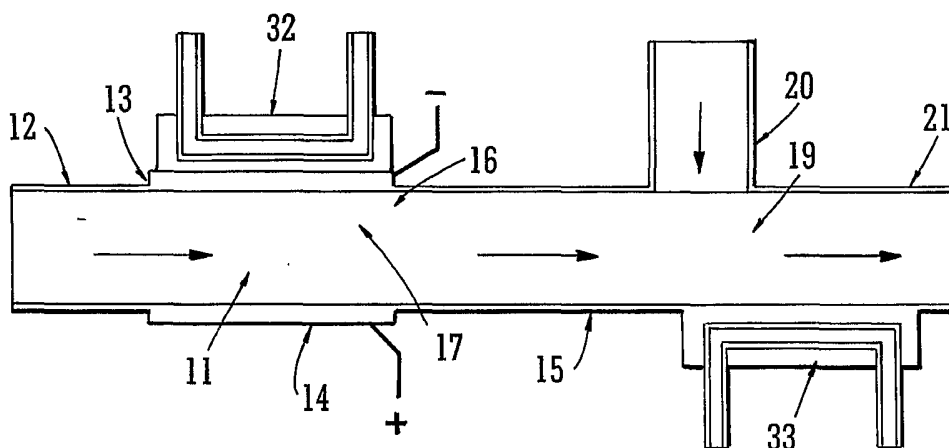

FIG. 15

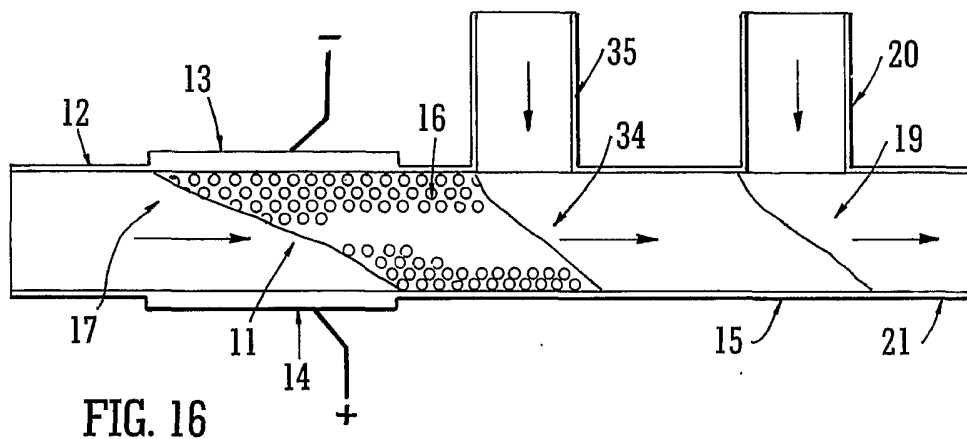

FIG. 16

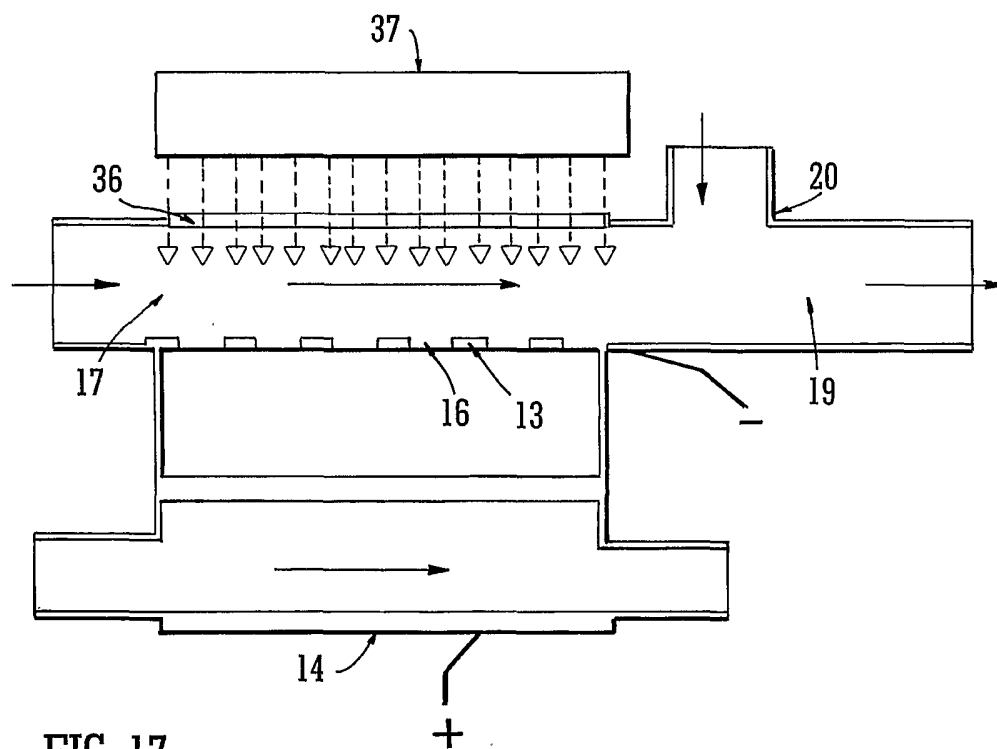

FIG. 17