

(19) World Intellectual Property  
Organization  
International Bureau



(43) International Publication Date  
18 November 2004 (18.11.2004)

PCT

(10) International Publication Number  
**WO 2004/099005 A2**

- (51) International Patent Classification<sup>7</sup>: **B65D**
- (21) International Application Number:  
PCT/US2003/034267
- (22) International Filing Date: 28 October 2003 (28.10.2003)
- (25) Filing Language: English
- (26) Publication Language: English
- (30) Priority Data:  
10/282,583 29 October 2002 (29.10.2002) US
- (71) Applicant: **ALCOA CLOSURE SYSTEMS INTERNATIONAL, INC.** [US/US]; 6625 Network Way, Suite 200, Indianapolis, IN 46278 (US).
- (72) Inventor: **GOLDMAN, Anatoliy, Y.**; 10635 East County Road, 600N, Indianapolis, IN 46234 (US).
- (74) Agents: **BEIRIGER, Tracey, D.** et al.; Eckert Seamans Cherin & Mellott, LLC, Alcoa Technical Center, 100 Technical Drive, Alcoa Center, PA 15069-0001 (US).
- (81) Designated States (*national*): AE, AG, AL, AM, AT (utility model), AT, AU, AZ, BA, BB, BG, BR, BY, BZ, CA, CH, CN, CO, CR, CU, CZ (utility model), CZ, DE (utility model), DE, DK (utility model), DK, DM, DZ, EC, EE (utility model), EE, EG, ES, FI (utility model), FI, GB, GD, GE, GH, GM, HR, HU, ID, IL, IN, IS, JP, KE, KG, KP, KR, KZ, LC, LK, LR, LS, LT, LU, LV, MA, MD, MG, MK, MN, MW, MX, MZ, NI, NO, NZ, OM, PG, PH, PL, PT, RO, RU, SC, SD, SE, SG, SK (utility model), SK, SL, SY, TJ, TM, TN, TR, TT, TZ, UA, UG, UZ, VC, VN, YU, ZA, ZM, ZW.
- (84) Designated States (*regional*): ARIPO patent (GH, GM, KE, LS, MW, MZ, SD, SL, SZ, TZ, UG, ZM, ZW), Eurasian patent (AM, AZ, BY, KG, KZ, MD, RU, TJ, TM), European patent (AT, BE, BG, CH, CY, CZ, DE, DK, EE, ES, FI, FR, GB, GR, HU, IE, IT, LU, MC, NL, PT, RO, SE, SI, SK, TR), OAPI patent (BF, BJ, CF, CG, CI, CM, GA, GN, GQ, GW, ML, MR, NE, SN, TD, TG).
- Published:**  
— *without international search report and to be republished upon receipt of that report*
- For two-letter codes and other abbreviations, refer to the "Guidance Notes on Codes and Abbreviations" appearing at the beginning of each regular issue of the PCT Gazette.*

(54) Title: CONTAINER CLOSURE WITH A MULTI-LAYER OXYGEN BARRIER LINER

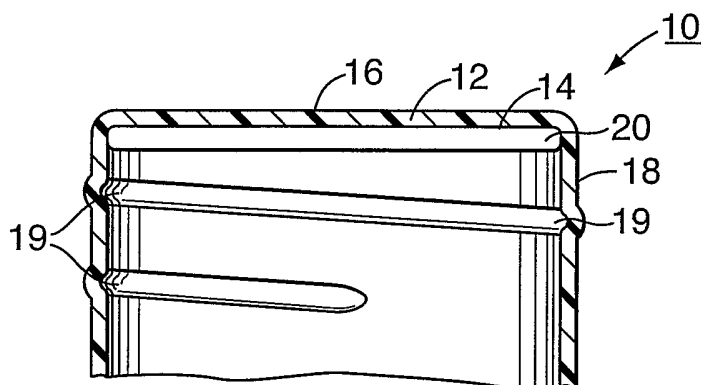

(57) Abstract: A container closure (10) with a multiple layer liner (20). The liner comprises a nylon gas transmission barrier (26) and a non-nylon layer (22) bonded by an adhesive layer (24). The nylon gas transmission barrier (26) may contain an additional passive gas transmission component comprising an in-situ polymerized inorganic clay. An additional active gas transmission component comprising a chemically reactive scavenger may be incorporated into at least one layer of the multiple layer liner (20). Materials of the liner are selected for their process conditions and resulting resistance to degradation.

WO 2004/099005 A2

## CONTAINER CLOSURE WITH A MULTI-LAYER OXYGEN BARRIER LINER

Field of the Invention

[0001] This invention is directed to container closures that provide a barrier to gases, particularly oxygen, carbon dioxide and nitrogen, that may transfer to or from the container sealed by the closure. The invention particularly pertains to a multiple layer closure liner with a nylon gas barrier, and at least one associated layer which provides the desired mechanical sealing with a container. Alternatively or additionally, a scavenging material may be incorporated into the nylon and/or non-nylon layers of the liner. Nanoparticles may be incorporated into the passive nylon barrier layer.

Background of the Invention

[0002] Closures for containers are effective barriers if the closures can both be adequately sealed onto a container after the container is filled, and can be subsequently opened easily by a consumer. To this end, so-called composite closure constructions, including an outer molded plastic shell, and an inner, disc-like sealing liner, have proven to be highly commercially successful, providing the desired sealing properties, while facilitating convenient consumer use. Closures of this type are illustrated in U.S. Patent Nos. 4,497,765 and 4,938,370, both hereby incorporated by reference.

[0003] Container closures that are designed to prevent the transfer of gases to or from the container may include a liner that may be made of multiple layers. Ethylene vinyl acetate ("EVA") is a common liner material and is known to provide a suitable seal of the closure to the container while also maintaining an opening torque in a range that is easily applied by the end user or consumer.

[0004] EVA closure liners are known to have a relatively high gas transmission rate, which presents a particular problem when the container to be sealed contains a carbonated beverage. In order to maintain the carbonated quality of the beverage, a particular carbon dioxide gas pressure must be maintained in the container. Carbonated beverages have a limited shelf life due, at least in part, to the gas transmission properties of the EVA liner.

[0005] Another problem with liners or closures that have a relatively high gas transmission rate is that oxygen may enter the container. Oxygen can degrade the taste of a carbonated beverage over time and may adversely affect other properties of the product in the container. This can be particularly problematic in the case of beer and other fermented beverages.

[0006] Reduction of gas transmission to or from containers has been improved by careful selection of container materials; however, a significant amount of gas transmission to or from the container still takes place through the closure. Some container formulations have included types of nylon. Closure liners that have been designed to reduce the amount of gas transmission through the closure have included polyvinylidene chloride ("PVDC"), polyethylene naphthalene ("PEN"), ethylene vinyl alcohol co-polymer ("EVOH"), and mixtures of these polymers. Because the EVA material does not provide a complete barrier to gas transfer this material has been layered with other compositions but, where EVA is tied to polyolefinic layers, the layers may delaminate in a relatively short period of time.

[0007] Metal or plastic closures for use with containers carrying beer, juice or soft drinks have included liners of a polymeric heterogeneous blend of unvulcanized and uncrosslinked butyl rubber and a thermoplastic polymer. Foamed polymer sealing layers have been used to retard, but not completely prevent, the migration of oxygen and carbon dioxide through container closures. However, the shelf life of products with these foamed liners may be only slightly improved with a retardation of oxygen migration, as there exists an obvious relationship between the rate of oxygen ingress to the container and the shelf life of the product.

[0008] Multiple layer closure liners have been used to inhibit gas transfer to and from containers. One example of a multiple layer closure liner has a gas barrier layer of ethylene vinyl alcohol copolymer ("EVOH") sandwiched between layers of EVA. These liners are formed by coextrusion process to prevent the gas barrier layer from being exposed to moisture. The EVOH barrier liners typically were comprised of nine coextruded layers. The layers of such liners may be bonded via an adhesive, or tie, layer to polyolefinic layers. These liners also may delaminate in a short period of time. Also, the effectiveness of EVOH as a barrier is reduced in environments with greater than about 70-80% of relative humidity. In container headspace, such as that for soft drink bottles, relative humidity may reach levels of 95-100%. Liners of this type were generally expensive and did not perform well.

[0009] Accordingly, there exists a need for a closure liner that provides an improved barrier to gas transfer to and from the container. There is further a need for such liners to avoid degradation while maintaining or improving the ease of manufacture of the liners.

[0010] The invention provides such a liner and method for making the liner that results in a closure that is more impervious to gas transfer, resists degradation and delamination and is

easily manufactured. These and other advantages of the invention, as well as additional inventive features, will be apparent from the description of the invention provided herein.

#### Brief Summary of the Invention

[0011] The multiple layer liners of the present invention are for container closures that inhibit ingress of oxygen and egress carbon dioxide or other transfer gases into and from the container. Closures with liners of the type described here are particularly useful for sealing and storing bottles of beverages that are subject to taste degradation or reductions in quality associated with a loss of carbonation or introduction of oxygen. Such beverages in particular include carbonated soft drinks and beer.

[0012] The invention provides a container closure with an outer shell having a top wall portion and a cylindrical side wall portion depending from the top wall portion. The closure includes a multiple layer liner positioned adjacent to an inside surface of the outer shell. The liner includes at least one nylon barrier layer, at least one non-nylon layer, and an adhesive layer bonding the nylon barrier layer to non-nylon layer.

[0013] In one form, the non-nylon material is an ethylene vinyl acetate-based material. In another form, the non-nylon layer is a combination of ethylene vinyl acetate and a polyolefinic material.

[0014] In another form of the invention, the closure further comprises an active scavenging material within the layer of ethylene vinyl acetate-based material. In a further form, the active scavenging material is selected specifically to react with a chemical selected from the group consisting of oxygen, carbon dioxide and nitrogen.

[0015] In one form, the passive nylon barrier incorporates inorganic nanoparticles, such as mineral clay material, as a passive barrier to gas transmission. The incorporation of the nanoparticles is accomplished by an in situ polymerization method. Alternatively or additionally, a reactive scavenging material may be incorporated into the nylon and/or non-nylon layers of the liner.

[0016] In a preferred embodiment, the passive nylon barrier layer, EVA layer, and the adhesive layer originate from materials having processing parameters in overlapping and/or adjacent ranges. The resulting multiple-layer liners have an adhesive strength of at least 8.5 pounds per inch.

[0017] In one form the invention is a process for manufacturing a container closure liner, the process includes the steps of selecting a nylon barrier material having a range of processing parameters, selecting a material based on ethylene vinyl acetate having processing parameters

in a range overlapping, or adjacent to, the nylon barrier materials processing parameters, selecting a tie material having processing parameters in a range overlapping the processing parameters of the nylon barrier material and the material based on ethylene vinyl acetate, and co-extruding the nylon barrier material, the tie material and the material based on ethylene vinyl acetate.

[0018] In yet another form, the invention is the container liner produced by the co-extrusion process described herein.

[0019] In yet another form, the invention is a multilayer liner for use in sealing a container, the liner comprising a co-extrusion of a passive barrier of nylon, a tie layer of adhesive material on the passive barrier of nylon, and two outer layers of non-nylon material.

[0020] Other features and advantages of the present invention will become readily apparent from the following detailed description, the accompanying drawings and the appended claims.

#### Brief Description of the Drawings

[0021] Figure 1 is a cross-section of a closure with a liner embodying the invention.

[0022] Figure 2 is a cross-section of the liner embodying the invention.

[0023] Figure 3 is an exploded view of a closure with a liner embodying the invention.

[0024] Figure 3a is a view of section 3a-3a of Figure 3.

[0025] Figure 4 is a schematic representation of a co-extrusion process that may be used to form the multi-layer co-extruded liners described herein.

[0026] Figure 5 is a graph that depicts the oxygen transmission rate across a sample of ethylene vinyl acetate based material ("EVA") at 80 percent relative humidity and 100% oxygen concentration.

[0027] Figure 6 is a graph that depicts the carbon dioxide transmission rate across a sample of ethylene vinyl acetate based material ("EVA") at 80 percent relative humidity and 100% carbon dioxide concentration.

[0028] Figure 7 is a graph that depicts the oxygen and carbon dioxide transmission rates across a sample nylon layer that contains nanoparticles at 100% carbon dioxide concentration and 100% oxygen concentration, respectively.

[0029] Figure 8 is a graph depicting relative humidity at two different temperatures at 5.5° and 23° of about between 95-100% relative humidity in a headspace in a bottle of beer.

[0030] Figure 9 is a graph that depicts the oxygen and carbon dioxide transmission rates across a sample of a multiple layer liner of the present invention at 100% carbon dioxide concentration and 100% oxygen concentration, respectively.

[0031] Figure 10 is a graph depicting the kinetics of oxygen transmission rate for three different multi-layer films at 100% oxygen concentration.

[0032] Figure 11 is a comparison of process temperatures for material layers of a closure liner.

[0033] Figure 12 depicts an example of operating parameters for a run of a process that may be used to produce the multi-layer liners described herein.

[0034] Figure 13 is a graph depicting a range of process temperatures for various nylons and other polymers.

[0035] Figure 14 is a bar graph depicting the adhesive strength of the co-extruded multi-layer liners as measured by T-peel testing.

[0036] Figure 15 is a graph that depicts the removal torque required to remove a closure with a liner of the present invention as compared to a standard liner of ethylene vinyl acetate.

#### Detailed Description of the Invention

[0037] While the present invention is susceptible of embodiment in various forms, there is shown in the drawings and will hereinafter be described a presently preferred embodiment of the invention, with the understanding that the present disclosure is to be considered as an exemplification of the invention and is not intended to limit the invention to the specific embodiment illustrated.

[0038] Referring to Figures 1-3, a closure **10** has an outer shell **12** with an inside surface **14** of a top wall portion **16**, and a cylindrical side wall portion **18** that originates at the top wall portion **16** and depends from the top wall portion **16** as an annular skirt to form a cup-shaped closure **10**. The inside surface of the cylindrical side wall portion **18** has helical screw threads **19** that engage corresponding screw threads of an associated container (not shown). A multiple layer liner **20** is positioned adjacent to the inside surface **14** of the top wall portion **16** of the outer shell **12** of the closure **10**. For use in container closures, the multiple layer liner **20** may be positioned adjacent to the top wall portion **16** only, or may extend along a portion of the cylindrical side wall portion **18**.

[0039] The multiple layer liner **20**, as depicted in Figure 2, has an EVA-based material layer **22** attached by a tie layer or adhesive layer **24** to a nylon layer **26**. The EVA-based material may be an EVA<sub>1</sub> material or an EVA<sub>2</sub> material. An example of the EVA<sub>1</sub> material layer **22** is

DF-6442, commercially available from W.R. Grace in Epernon, France. EVA<sub>1</sub> is based on EVA and another polyolefinic material. An example of EVA<sub>2</sub> material is DF-6601, commercially available from W.R. Grace in Epernon, France. EVA<sub>2</sub> is a mixture of EVA and another polyolefinic material and also a scavenger is incorporated into the mixture. Further, the liner **20** of Figure 2 in accordance with the preferred form has a second adhesive layer **28** that bonds the nylon layer **26** to a second layer of EVA-based material **30**. The EVA-based material layers **22** and **30** are also known as skin layers because they are the outermost layers of the multiple layer liner **20**. The second layer of EVA-based material **30** usually faces the headspace **31** within a container sealed by the closure **10**. Several nylon formulations were found to have varying levels of effectiveness as a gas transfer barrier in a closure. One suitable nylon containing the nanoparticles is XA-2908 and is commercially available from Honeywell International in Morristown, N.J. Another nylon, XE-2945, may also be used and is also available from Honeywell. Another suitable nylon is a nylon copolymer, Grivory HB FE 4581, available from EMS Chemie (North America) in Sumter, South Carolina. The tie layers **24** are typically functionalized polyolefins and may be, for example, PX-108 ("PX") available from Equistar Chemical Co., Cincinnati, Ohio.

[0040] Materials based on EVA in combination with another polyolefinic material have not before been used in multilayer structures. The EVA- layers **22** described here are each of a thickness in the range of about 10 mils to about 12 mils. The tie layers **24** are about 0.3 to 0.8 mils thick, and preferably between about 0.3 and about 0.5 mils. The nylon layer **26** is about 1.0 mil to about 1.5 mils thick. Figure 4 is a schematic representation of a co-extrusion process that may be used to produce the multi-layer structures described herein

[0041] Additional reduction of gas transfer to and from the container may be achieved by the substitution of nylon with a nylon nanocomposite material. The nanoparticles within the nanocomposite material may be, for example, clay particles and may account for about 2% to about 5% by weight of the nylon layer **26**. Preferably, the clay particles are mineral clay particles. An example of a suitable inorganic nanoparticle is montmorillonite.

[0042] Figure 5 is a graph depicting the oxygen transmission rate across a sample of EVA, herein known as EVA<sub>1</sub> where the EVA does not contain a scavenger, at varying temperatures. As the temperature exceeds 42°C, the oxygen transmission rate increases significantly. Figure 6 is a graph depicting the carbon dioxide transmission rate across a sample of EVA<sub>1</sub> at varying temperatures. Similar to the transmission rate increase for oxygen with increasing

temperature, the carbon dioxide transmission rate increases significantly at temperatures exceeding 42°C.

[0043] Figure 7 depicts the oxygen and carbon dioxide transmission rates across a sample of nylon containing the nanoparticles as described earlier. The oxygen transmission rate at 42°C begins to increase as depicted in Figure 7; however, the value remains much lower than the oxygen transmission rate across EVA<sub>1</sub> as depicted in Figure 5. Similarly, the carbon dioxide transmission rate at 42°C and above in Figure 7 remains significantly lower than the carbon dioxide transmission rate across EVA<sub>1</sub> as depicted in Figure 6. Some containers that store beverages obtain relative humidity levels of between 95-100%, such as the levels obtained in bottles of beer as exemplified in Figure 8. The oxygen permeability of materials in the nylon family perform as well in very high relative humidity environments of 95-100% as they do in moderate relative humidity environments and in environments with relative humidity of between 70-80%. In fact, some nylons, such as MXD-6 perform at the same level or better in the 95-100% relative humidity range than they do in moderate relative humidity environments and in the relative humidity range of 70-80%. Good inhibition of oxygen permeability is important in closure applications.

[0044] Figure 9 depicts the oxygen and carbon dioxide transmission rates across a multiple layer film of the configuration depicted in Figure 2. The oxygen transmission rate is further reduced from the values depicted in Figure 6. The carbon dioxide transmission rate depicted in Figure 9 is essentially the same as the rate depicted in Figure 7. Figure 8 suggests that the majority of the reduction in oxygen transfer across the liner is due to the passive barrier nylon layer containing the nanoparticles. Figure 10 depicts the kinetics of oxygen transmission rate across multiple layer films.

[0045] The nylon layer **26** of the multiple layer liner **20** acts as a good barrier and significantly inhibits gas transmission to and from the container. Additional active inhibition of gas transmission to and from the container may be achieved by the incorporation of active scavengers to react with oxygen, carbon dioxide, or other transfer gases. Examples of active scavengers are polyamides, sulfite oxygen scavengers and ascorbate in combination with a sulfite. An example of an EVA<sub>2</sub> where the layer contains a scavenger is DF-6601, described earlier. It is important to have adequate water vapor transmission rate ("WVTR") through layers of the liner that contain a scavenger in order to provide adequate moisture to the scavenger because moisture is a trigger to begin scavenger activity. In addition to inhibiting oxygen permeability, the EVA-based materials of the present invention also provide WVTR

to provide adequate scavenger activity. Another suitable example of EVA<sub>2</sub> is DF-30375, also from W.R. Grace, Epernon, France. Examples of suitable EVA<sub>1</sub> materials (having no oxygen scavenger) include DF-6442, described earlier, and DF-30376, both also available from W.R. Grace, Epernon, France. Active scavengers have a capacity and once the capacity has been utilized, the passive nylon barrier, that may contain nanoparticles, and multiple layers of the liner are still in place. The capacity of the scavenger may be increased within the closure liner by incorporating the scavenger into more than one layer of EVA when multiple layers of EVA are used in the liner. Preferably, the scavenger is included in the EVA layer that is closest to the contents, i.e., facing the headspace **31**, of the container to be sealed by the closure **10**.

[0046] The multiple layer liner **20** is co-extruded, suitably cut and fitted into the container closure **10**. The co-extrusion process is simplified by the selection of material layers that have overlapping process parameters, or process parameters that are in a range near to the process parameters of the materials of the adjacent layers. The preferred nylon is XA-2908. This nylon contains nanoparticles that provide an additional passive barrier to gas transfer.

[0047] The range of processing temperatures determined by this invention to be useful for co-extruding the materials of the liner are listed in Figure 11 for each material used in the multiple layer liner. The dashed lines indicate extension beyond the ordinarily acceptable temperature ranges at which these materials are processed according to the invention described herein. The solid lines, such as those that surround DF 6442, DF 6601 and XA-2908 in Figure 11, indicate standard temperatures at which these materials are known to be successfully processed. The extension of the processing temperature parameter is extended of the co-extrusion for any one material only after the co-extrusions are shown to be stable and reproducible. The materials used are selected for their overlapping or adjacent processing temperature parameter with the materials that will be used in the co-extrusion. Therefore, the liner within the closure of the present invention is a co-extrusion of the materials having similar or overlapping process parameters. Figure 12 depicts an example of operating parameters for a run of a process that may be used to produce the multi-layer liners described herein. By selecting material layers of the multi-layer liner that have similar or overlapping or adjacent process parameters, the resulting liner is resistant to degradation and delamination. Figure 13 depicts the standard range of processing temperatures for three types of nylon (MXD-6, Nylon-6, Nylon-66) and four other polymers (polyethylene terephthalate ("PET"), polyethylene ("PE"), polypropylene ("PP") and ethylene vinyl alcohol ("EVOH")).

The diagramming of materials that may potentially be used in combination such as in Figures 11 or 13, aids in the selection of combinations of materials for co-processing and co-extrusion applications.

[0048] Aside from their barrier properties, nylons, such as Nylon 6, are also useful for barrier closures due to their properties of puncture, tear and abrasion resistance, and for their thermoformability. To obtain the narrowest range of temperatures required for manufacture of the structure of the closures disclosed herein, the nylon 6 preferably has a low melting temperature.

### **Determination of Strength of Adhesion**

[0049] The adhesive load of liners manufactured by this method was analyzed. Samples of the co-extruded multi-layer material were tested as they came off-line and then again after 48 hours or more. The adhesive load was measured using the method prescribed by American Society for Testing and Materials ("ASTM") D1876-2001. Results from the adhesive test are summarized in Table 1 and depicted in bar graph form in Figure 14.

[0050] For the following example Structures, T-peel testing was used to determine adhesive load as an indication of adhesive strength. These example structures, of course, should not be construed as in any way limiting the scope of the invention.

#### **STRUCTURE 1**

[0051] This example is the co-extrusion with a core material of the nylon copolymer Grivory HB EF 4581, tie material of PX on both sides of nylon copolymer in the co-extrusion and the EVA<sub>1</sub> known as DF-6442 on both outer surfaces of the laminate. This Structure may be summarized as EVA<sub>1</sub>/PX/Grivory HB EF 4581/PX/EVA<sub>1</sub>. Figure 14 includes examples of Structure 1 co-extrusions having both 1 and 1.5 mils thickness of Grivory HB EF 4581.

#### **STRUCTURE 2**

[0052] This example is the co-extrusion with a core material of the nylon XA-2908, tie material of PX on both sides of XA-2908 in the co-extrusion and the EVA<sub>1</sub> (DF-6442) on both outer surfaces of the co-extrusion. This Structure may be summarized as EVA<sub>1</sub>/PX/XA-2908/PX/EVA<sub>1</sub>.

#### **STRUCTURE 3**

[0053] This example is the co-extrusion with a core material of the nylon XA-2908, tie material of PX on both sides of the XA-2908 in the co-extrusion and EVA<sub>1</sub> (DF-6442) on one outer surface of the co-extrusion and the EVA<sub>2</sub> known as DF-6601 on the opposite outer surface of the co-extrusion. This Structure may be summarized as EVA<sub>1</sub>/PX/XA-

2908/PX/EVA<sub>2</sub>. Figure 14 includes examples of Structure 3 co-extrusions having both 1 and 1.5 mils thickness of XA-2908.

#### STRUCTURE 4

[0054] This example is the co-extrusion with a core material of the nylon copolymer HB EF 4581, tie material of PX on both sides of nylon copolymer in the co-extrusion and the EVA<sub>1</sub> DF-6442 on one outer surface of the co-extrusion and the EVA<sub>2</sub> DF-6601 on the opposite outer surface of the co-extrusion. This Structure may be summarized as EVA<sub>1</sub>/PX/ Grivory HB EF 4581/PX/EVA<sub>2</sub>.

#### STRUCTURE 5

[0055] This example is the co-extrusion with a core material of XA-2908, tie material of PX on both sides of the XA-2908 the co-extrusion and the EVA<sub>2</sub> DF-6601 on both opposite, outer surfaces of the co-extrusion. This Structure may be summarized as EVA<sub>2</sub>/PX/ XA-2908/PX/EVA<sub>2</sub>.

[0056] Table 1. Summary Of T-Peel Testing (ASTM D1876-2001) Of Individual Sheet Specimens 1-4 (reported in pounds per inch).

Structure	Spec. 1	Spec. 2	Spec. 3	Spec. 4	Avg.	Std. Dev.
1	8.72	9.74	8.08	8.30	8.72	0.84
1	7.82	10.30	9.50		9.20	1.26
1	9.46	9.40	9.02		9.30	0.24
1	10.02	9.10	9.60		9.58	0.46
2	9.24	8.98	11.24		9.82	1.24
2	9.84	11.68	9.88		10.46	1.06
3	10.42	9.58	9.40	10.44	9.96	0.54
3	10.44	10.30	11.00	11.14	10.72	0.38
4	9.62	7.52	8.60		8.58	1.06
4	9.76	7.58	5.80		7.72	1.98
3	9.70	10.76	11.66		10.70	0.98
3	11.72	7.90	11.17		10.44	2.20

### Removal Torque Testing

[0057] Removal torque was tested across a range of time and conditions. Containers with closures applied were cycled through several conditions and tested at various stages for removal torque. Bottles sealed with the closures having the multi-layer co-extruded liners described herein were moved from one controlled temperature area to another as described. Containers sealed with the standard multi-layer EVA (“Tri-Shield”) liner material included an EVOH barrier layer. The standard EVA liner is a nine-layer liner with EVOH as a barrier layer. Closures with liners were sealed onto containers and conditioned at a temperature of 95°F for two days and then stored at ambient temperature (roughly 70°F) for 24 hours. Removal torque was then measured. Then containers were conditioned at 40°F for 10 days and transferred to ambient temperature for 24 hours prior to having removal torque tested. Then the closed containers were conditioned at 95°F for two days and then returned to ambient temperature for 24 hours prior testing removal torque. Then the closed containers were conditioned again at 40°F for 10 days, returned to ambient temperatures for 24 hours and tested for removal torque.

[0058] Closures containing the multiple layer liner with a nylon core were similarly sealed onto containers, conditioned and stored. Figure 15 depicts a graph comparing the torque required to remove the closures from the containers. The term “N1” generally refers to Structures 2, 3, and 5 described herein and the term “N4” generally refers to Structures 1 and 4 described herein. The multiple layer liner with the nylon core performs better than the standard material and does not require significant additional torque to open the container under any of the conditions observed.

[0059] Closures **10** having only a passive nylon barrier **26** and a tie layer **28** bonding a layer of EVA<sub>1</sub> or EVA<sub>2</sub> material **30** to the passive nylon barrier also serve as good barriers against ingress and egress of gases such as oxygen, carbon dioxide and nitrogen. The EVA<sub>1</sub> or EVA<sub>2</sub> layer **28** will face the headspace **31** and form a seal with the container.

[0060] All references, including publications, patent applications, and patents, cited herein are hereby incorporated by reference to the same extent as if each reference were individually and specifically indicated to be incorporated by reference and were set forth in its entirety herein.

[0061] The use of the terms “a” and “an” and “the” and similar referents in the context of describing the invention (especially in the context of the following claims) are to be construed to cover both the singular and the plural, unless otherwise indicated herein or

clearly contradicted by context. Recitation of ranges of values herein are merely intended to serve as a shorthand method of referring individually to each separate value falling within the range, unless otherwise indicated herein, and each separate value is incorporated into the specification as if it were individually recited herein. All methods described herein can be performed in any suitable order unless otherwise indicated herein or otherwise clearly contradicted by context. The use of any and all examples, or exemplary language (e.g., "such as") provided herein, is intended merely to better illuminate the invention and does not pose a limitation on the scope of the invention unless otherwise claimed. No language in the specification should be construed as indicating any non-claimed element as essential to the practice of the invention.

[0062] Preferred embodiments of this invention are described herein, including the best mode known to the inventors for carrying out the invention. Of course, variations of those preferred embodiments will become apparent to those of ordinary skill in the art upon reading the foregoing description. The inventors expect skilled artisans to employ such variations as appropriate, and the inventors intend for the invention to be practiced otherwise than as specifically described herein. Accordingly, this invention includes all modifications and equivalents of the subject matter recited in the claims appended hereto as permitted by applicable law. Moreover, any combination of the above-described elements in all possible variations thereof is encompassed by the invention unless otherwise indicated herein or otherwise clearly contradicted by context.

## WHAT IS CLAIMED IS:

1. A container closure, comprising:
  - an outer shell having a top wall portion and a cylindrical side wall portion depending from the top wall portion; and
  - a multiple layer liner positioned adjacent to an inside surface of the outer shell, the liner comprising at least one nylon barrier layer, at least one non-nylon layer, and an adhesive layer bonding the nylon barrier layer to non-nylon layer.
2. The container closure of claim 1 wherein the non-nylon layer is an ethylene vinyl acetate-based material.
3. The container closure of claim 2 further comprising an active scavenging material within the layer of ethylene vinyl acetate-based material.
4. The container closure of claim 3 wherein the active scavenging material is selected specifically to react with a chemical selected from the group consisting of: oxygen, carbon dioxide and nitrogen.
5. The container closure of claim 1 wherein the non-nylon layer is a combination of ethylene vinyl acetate and a polyolefinic material.
6. The container closure of claim 1 further comprising an inorganic particulate material within the nylon layer.
7. The container closure of claim 6 wherein the inorganic particulate material is a mineral clay material.
8. The container closure of claim 6 wherein the inorganic particulate material is montmorillonite.
9. The container closure of claim 8 wherein the nylon layer was made by incorporation of the mineral clay material into a nylon matrix by in situ polymerization method.
10. The container closure of claim 1 wherein the barrier material is a composite material.

11. The container closure of claim 10 wherein the composite material is a nanocomposite with a nylon matrix which was made by in situ polymerization.
12. A container closure, comprising:
  - a closure shell having a top wall portion and a cylindrical side wall portion depending from the top wall portion;
  - a multiple layer liner positioned adjacent to an inside surface of the closure shell, the liner comprising at least one passive nylon barrier layer, at least a first skin layer sealing the closure to the container, and an adhesive layer bonding the passive nylon barrier layer to the skin layer; and
  - wherein the nylon barrier layer, skin layer, and the adhesive layer originate from materials having processing parameters in overlapping or adjacent ranges.
13. The container closure of claim 12 wherein the multiple layer liner has an adhesive strength of at least 8.5 pounds per inch.
14. The container closure of claim 1 wherein the multiple layer closure liner further comprises a second skin layer of material based on ethylene vinyl acetate, wherein the second skin layer incorporates an oxygen scavenger.
15. The container closure of claim 14 wherein the first skin layer also incorporates the oxygen scavenger.
16. The container closure of claim 14 wherein the second skin layer toward a headspace of the container.
17. A process for manufacturing a container closure liner, the process comprising the steps of:
  - selecting a nylon barrier material having a range of processing parameters;
  - selecting a material based on ethylene vinyl acetate having processing parameters in a range overlapping, or adjacent to, the nylon barrier materials processing parameters;
  - selecting a tie material having processing parameters in a range overlapping the processing parameters of the nylon barrier material and the material based on ethylene vinyl acetate; and
  - co-extruding the nylon barrier material, the tie material and the material based on ethylene vinyl acetate.

18. The container closure liner produced by the process of claim 17.
19. A multi-layer liner for use in sealing a container, the liner comprising:  
a co-extrusion comprising:  
a passive barrier of nylon;  
a tie layer of adhesive material on the passive barrier of nylon; and  
two outer layers of a non-nylon material.
20. The multi-layer liner of claim 19 further comprising an active scavenging material within one layer where the one layer is the passive barrier of nylon or one of the outer layers of the non-nylon material.

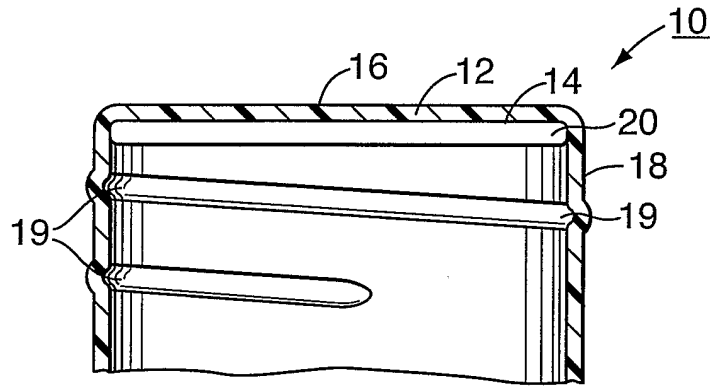

FIG. 1

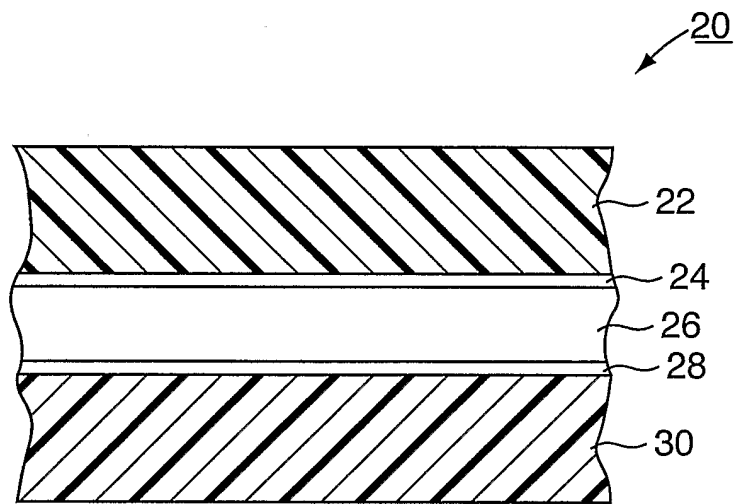

FIG. 2

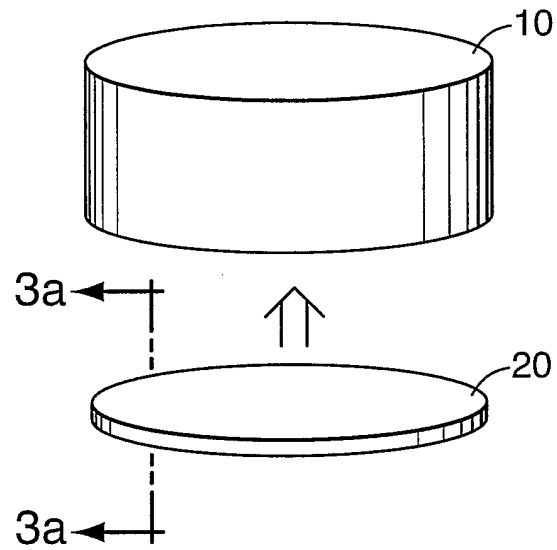

FIG. 3

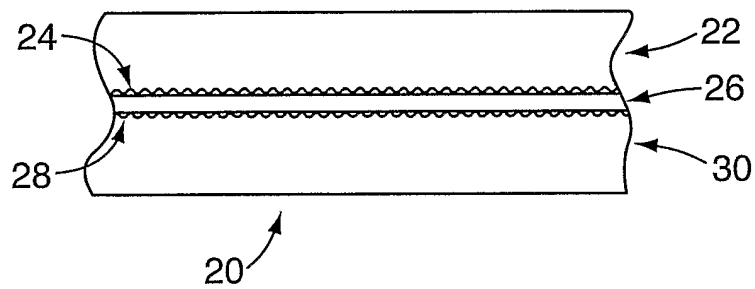

FIG. 3a

### MULTI-LAYER CO-EXTRUSION PROCESS

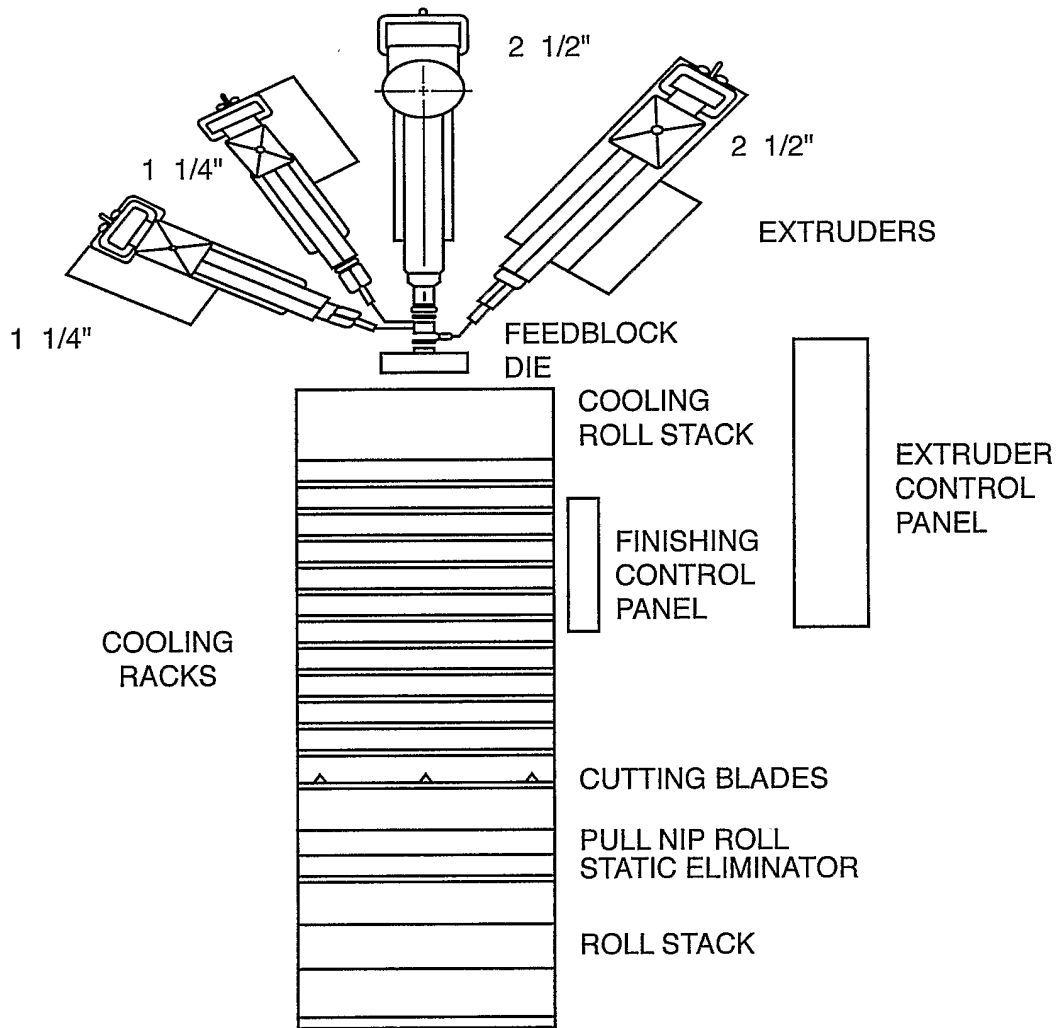
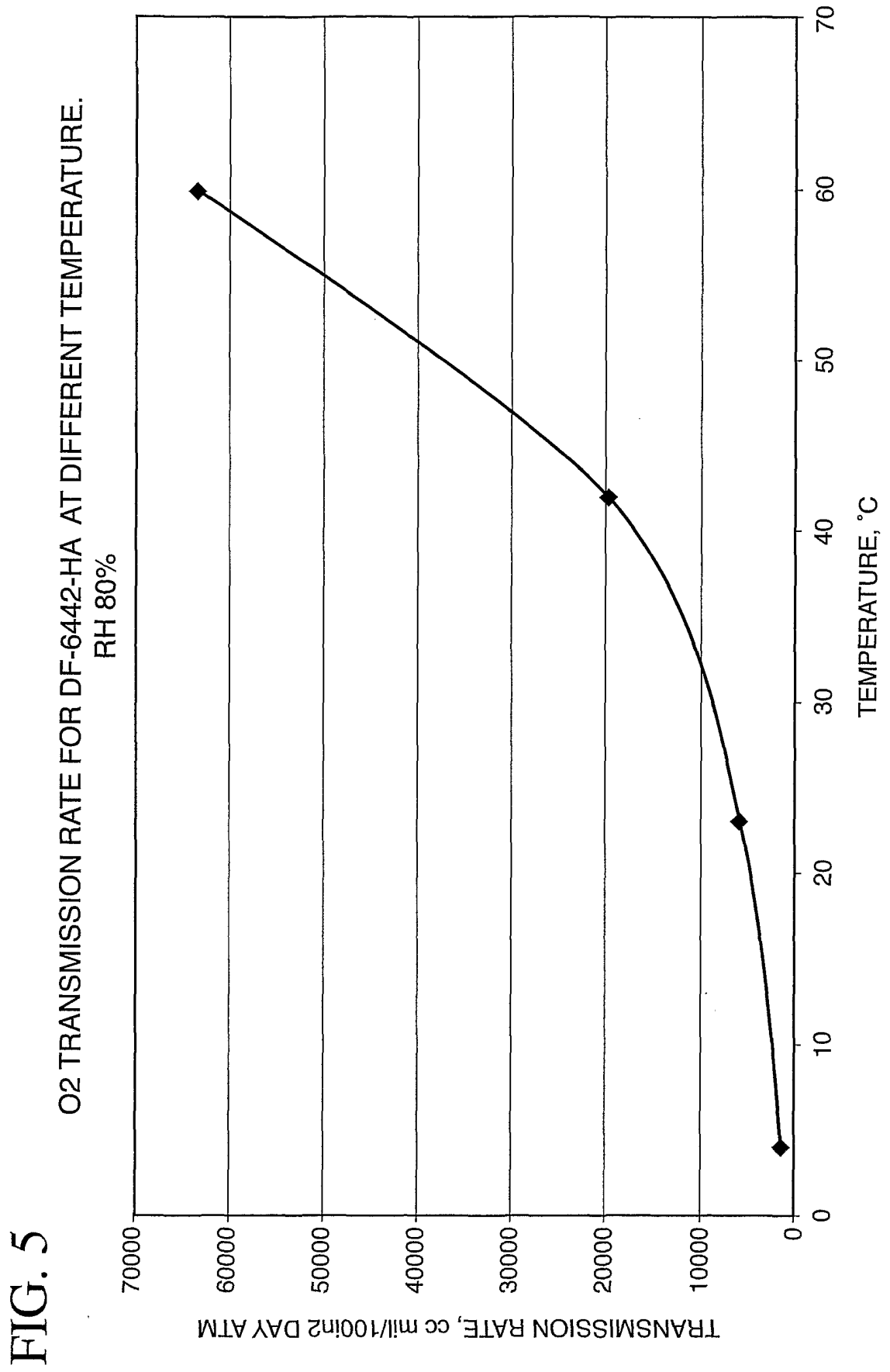
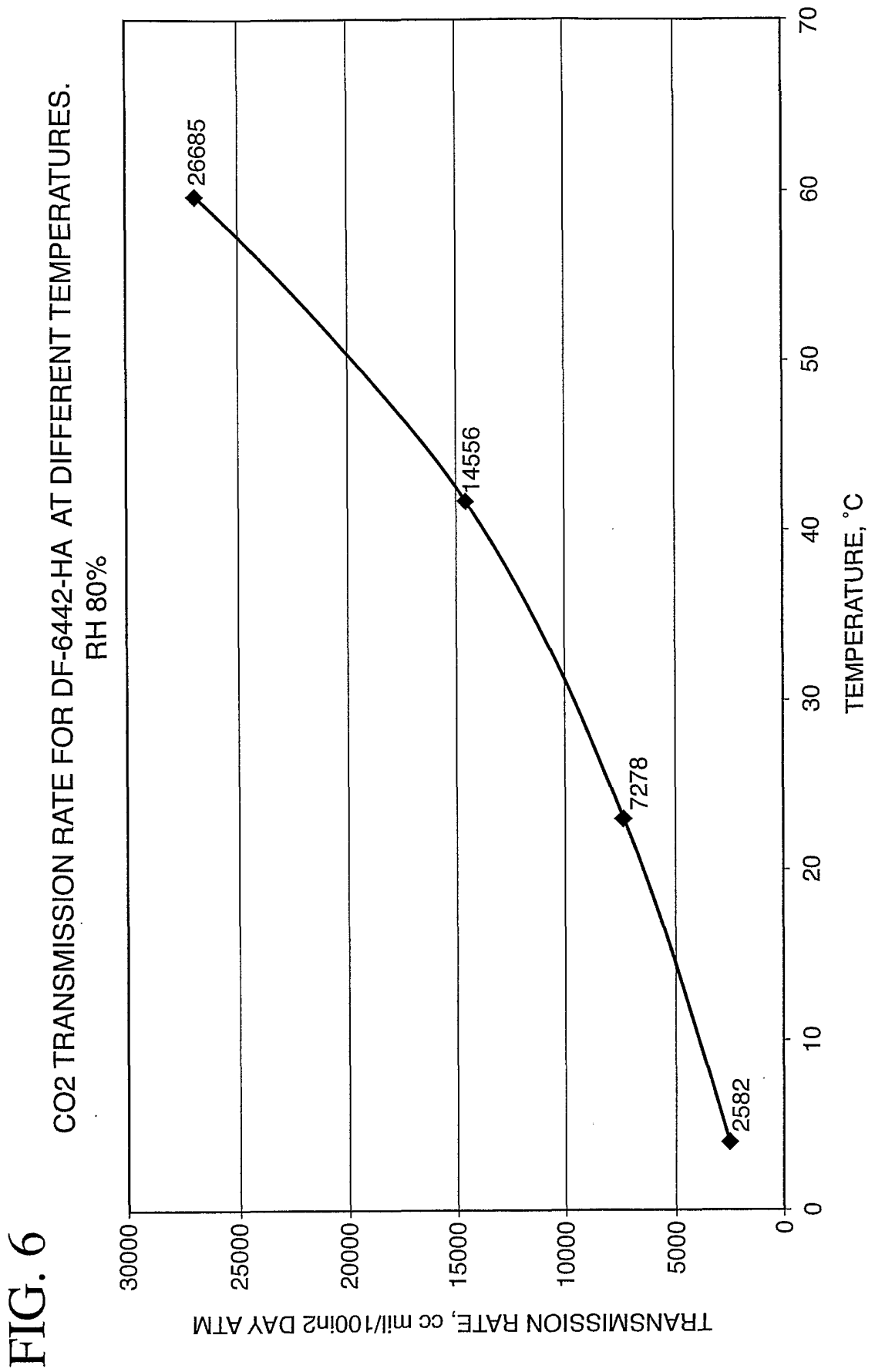

FIG. 4





**FIG. 7** COMPARISON BETWEEN O2 AND CO2 TR OF NANO-NYLON AT DIFFERENT TEMPERATURES. RH 80%

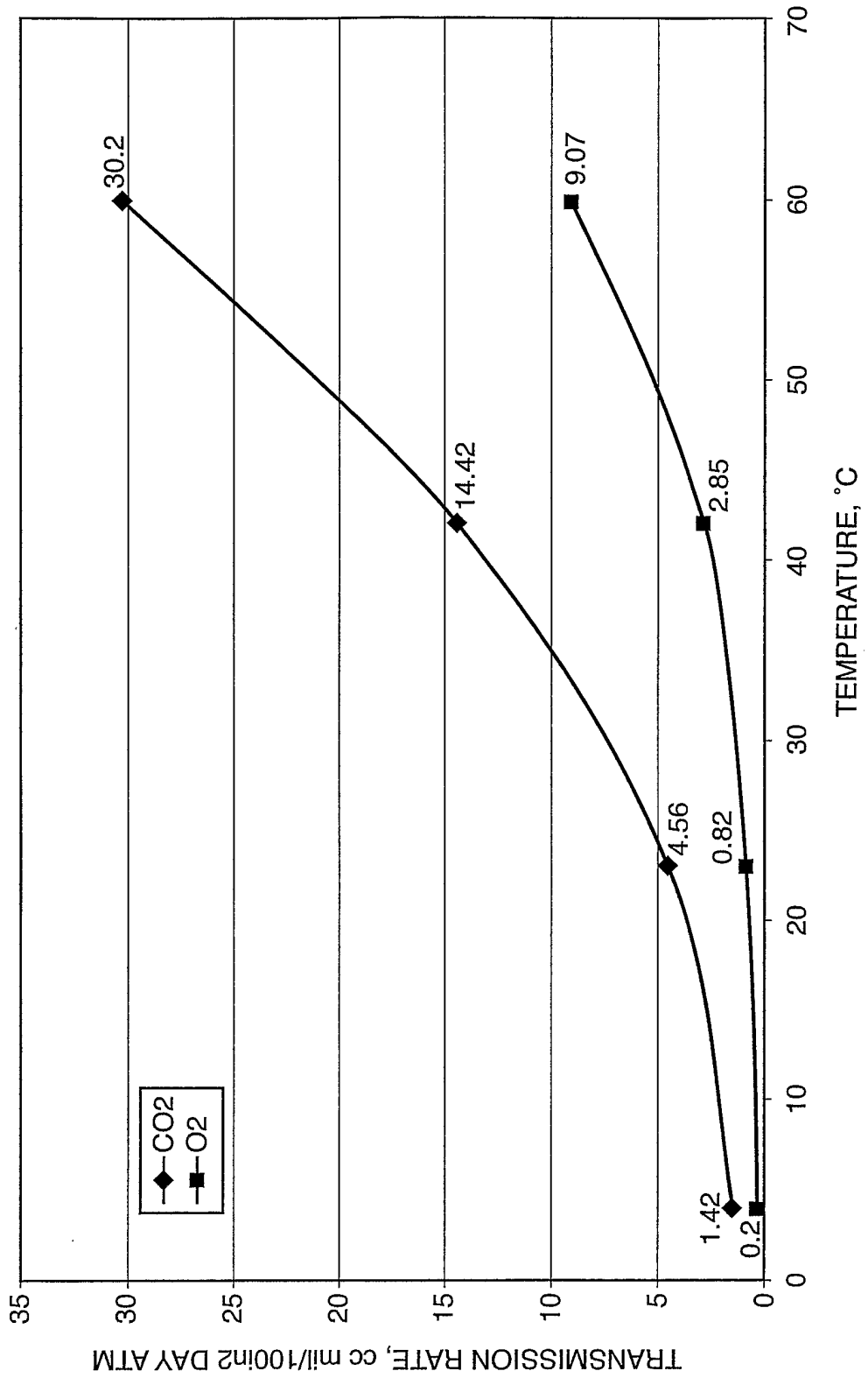

FIG. 8 TEMPERATURE - HUMIDITY TEST

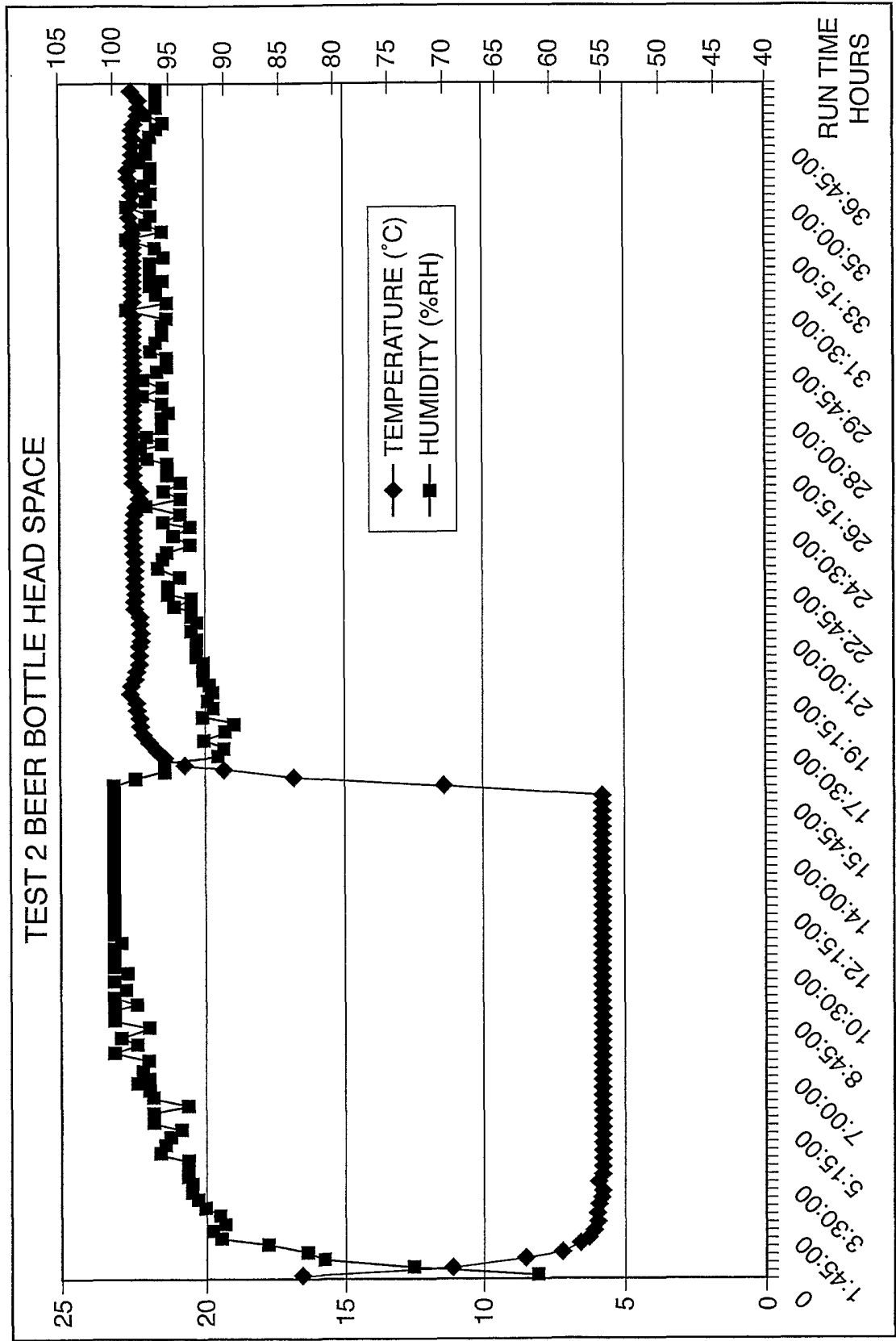
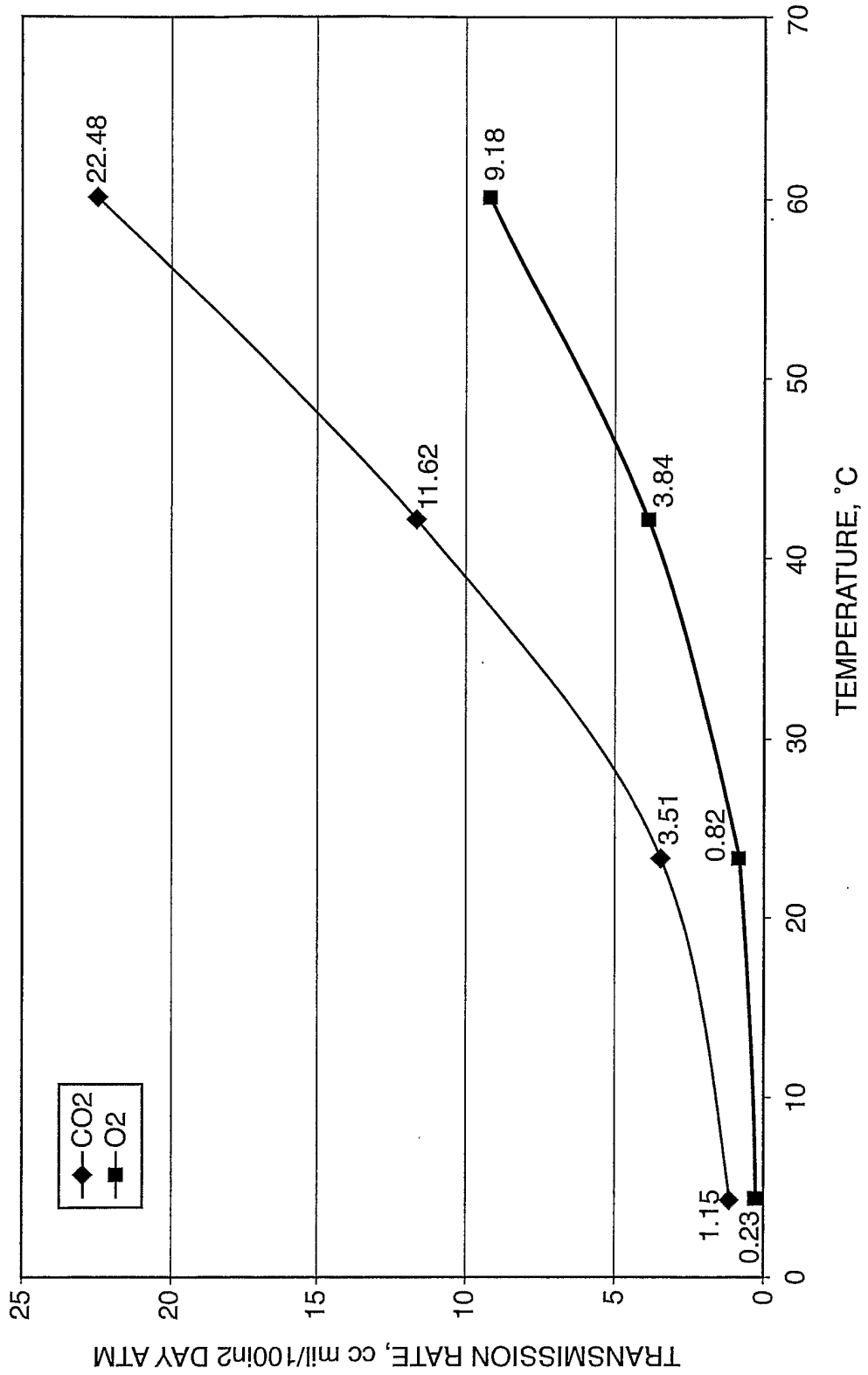

FIG. 9

COMPARISON BETWEEN O2 AND CO2 TR OF MULTI-LAYER FILM WITH NANO-NYLON AT DIFFERENT TEMPERATURES. RH 80%



**FIG. 10**  
OXYGEN TRANSMISSION RATE FOR MULTI-LAYER FILMS  
AT 23°C AND 80% RH

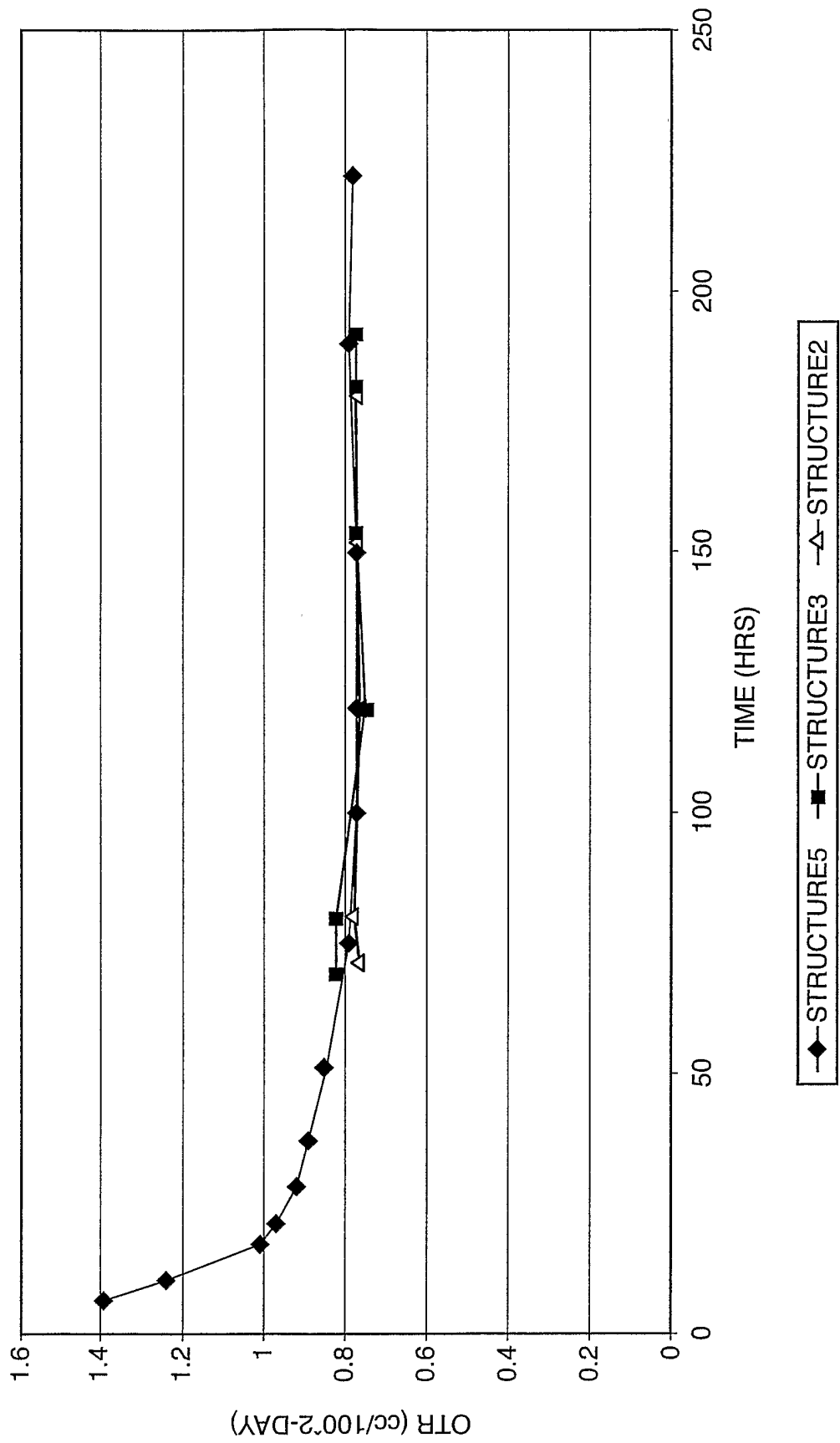



FIG. 12

LINE RUN SHEET

RESIN	DF 6442	X-2908	PX 108	DF 6601
RPM	34	40	24	22
PRES. (PSI)	540/530			11320
		TEMPERATURE °C		
ZONE 1	331	380	359	300
ZONE 2	331	449	370	320
ZONE 3	340	450	374	330
ZONE 4	341			340
GATE	N/A	450	372	
ADAPTOR	N/A	N/A		340
ACT MELT	330	445	380	332
FEED TUB. 1		456	371	
FEED TUB. 2	N/A	N/A	TOP CHILL	
FEED BL. 1	446		ROLL	91
FEED BL. 2	446		CENTER	
DIE 1	455		CHILL ROLL	105
DIE 2	455		BOTTOM	
DIE 3	454		CHILL ROLL	100



FIG. 14

T-PEEL SHEET DATA  
ALCOA CSI CONSTRUCTIONS

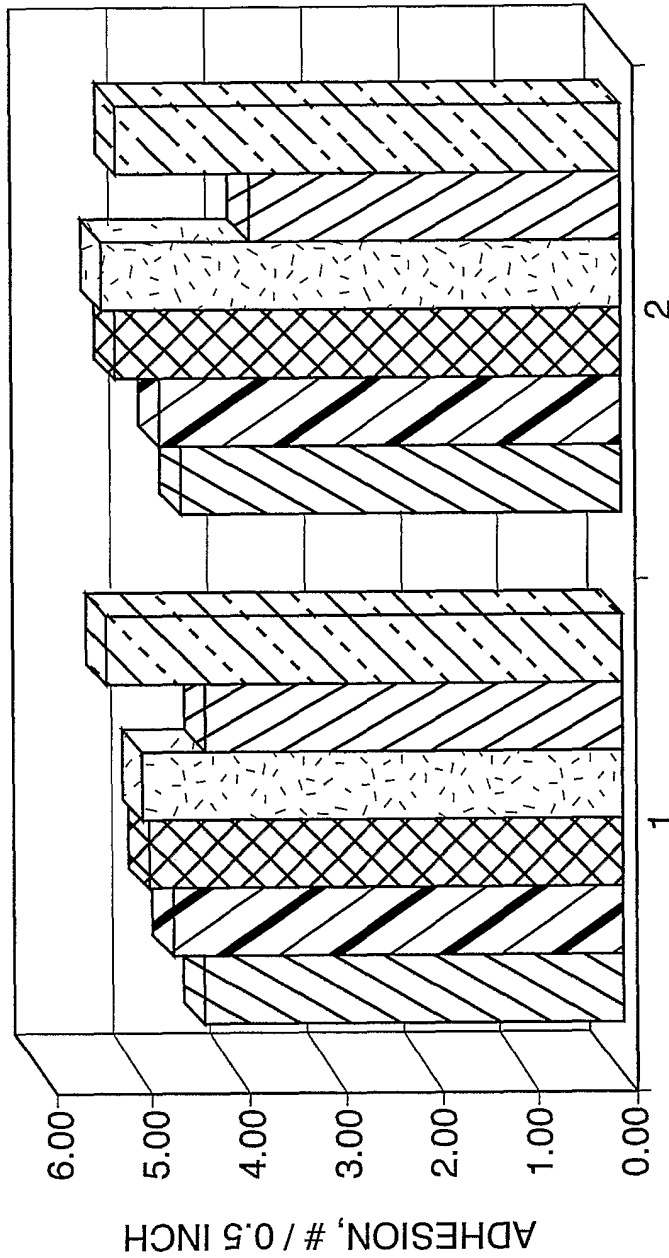

RUN NUMBER / CONSTRUCTION

1 = LEFT SIDE; 2 = RIGHT SIDE

- ▨ EVA1/PX/N4/PX/EVA1
- ▩ EVA1/PX/N1/PX/EVA2
- ▧ EVA1/PX/N4/PX/EVA2
- ▦ EVA1/PX/N1/PX/EVA1
- ▤ EVA1/PX/N4/PX/EVA1
- ▣ EVA1/PX/N1/PX/EVA2

FIG. 15

REMOVAL TORQUE ACROSS TIME AND CONDITIONS  
+/- 3 SIGMA

