

[54] **APPARATUS FOR CONTINUOUSLY CASTING TUBES**
 [76] Inventor: **Alfred J. Wertli**, Poststrasse 15,
 8406 Winterthur, Switzerland
 [22] Filed: **Aug. 6, 1970**
 [21] Appl. No.: **61,701**

[30] **Foreign Application Priority Data**
 Aug. 8, 1969 Switzerland.....12261/69
 [52] U.S. Cl.....164/283
 [51] Int. Cl.....B22d 11/12
 [58] Field of Search.....164/273, 260, 261,
 164/83, 283, 82, 85

[56] **References Cited**

UNITED STATES PATENTS

3,578,065	5/1971	Langer.....	164/85
3,481,391	12/1969	Nowak.....	164/85 X
1,748,851	2/1930	Smith.....	164/283
3,268,959	8/1966	Babel et al.....	164/85 X
2,707,813	5/1955	Dickson.....	164/85 X

3,078,527	2/1963	Valyi et al.....	164/83 X
3,487,876	1/1970	Bucci.....	164/85 X
3,506,059	4/1970	Burkart et al.....	164/82
3,398,780	8/1968	Yearley.....	164/88 X
3,650,311	3/1972	Fritsche.....	164/52

FOREIGN PATENTS OR APPLICATIONS

607,386	8/1960	Italy.....	164/85
---------	--------	------------	--------

Primary Examiner—H. A. Kilby, Jr.
Assistant Examiner—V. K. Rising
Attorney—Kenyon and Kenyon Reilly Carr and Chapin

[57] **ABSTRACT**

In apparatus for the continuous casting of tubing the core mandrel is hollowed for a portion of its length with the wall thickness of the hollowed portion progressively decreasing in the direction of withdrawal of the cast tube. The shape of the hollowed portion can be varied to control the flow of heat through the mandrel to produce the desired effect on the solidification process. A cooling fluid can be supplied to the mandrel cavity, if desired.

14 Claims, 1 Drawing Figure

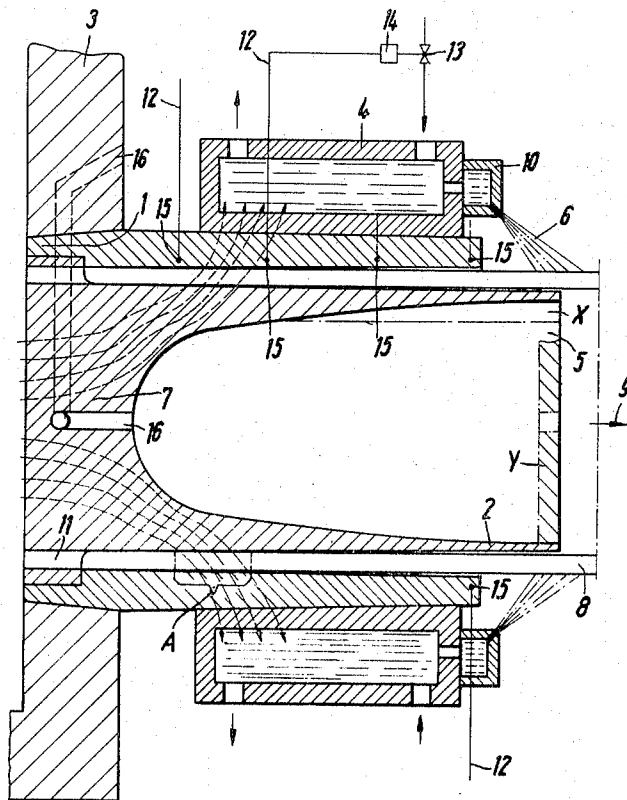

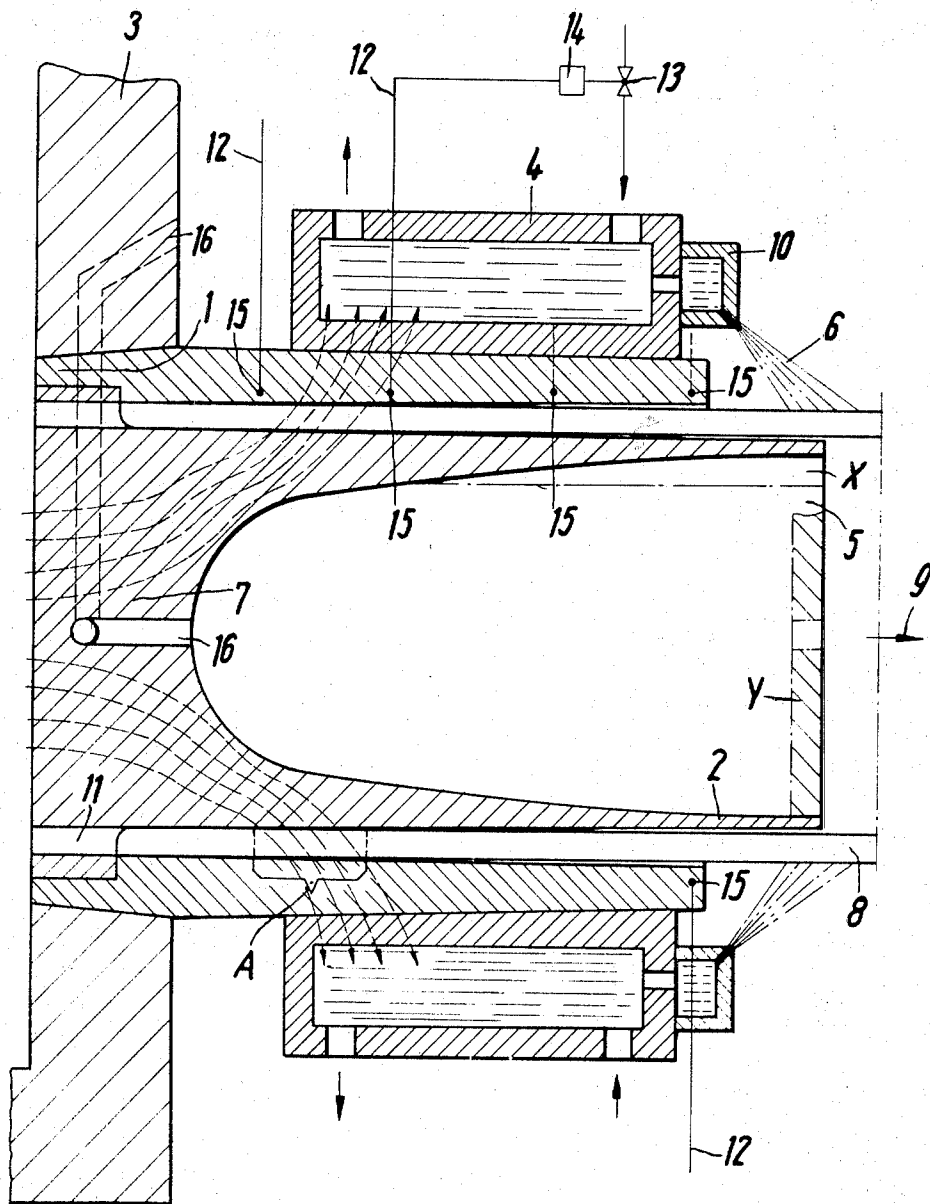

Inventor:

ALFRED J. WERTLI

BY

Tenyon & Tenyon Kelly Carr & Chapin
ATTORNEYS

APPARATUS FOR CONTINUOUSLY CASTING TUBES

BACKGROUND OF THE INVENTION

This invention relates to the continuous casting of tubes, and more particularly to apparatus for the continuous casting of tubes from metals such as cast iron, copper, and copper alloys.

Apparatus for continuous casting of metal tubes is well known and in its usual form comprises an elongated hollow mold connected at one end to and serving as the outlet of a furnace for supplying molten metal to be cast. A mandrel is positioned coaxially within the mold to serve as a core. The annular space between the outer surface of the mandrel and the inner surface of the mold thus becomes a conduit for the molten metal flowing from the furnace. The lengths of the mold and mandrel must be sufficient so that the molten metal will have solidified before leaving the other end of the mold. To assist in cooling the metal being cast, the outside of the mold is usually surrounded by a cooling means, such as a circulating water jacket.

In the prior casting apparatus, solid mandrels have been used. However, such mandrels have conducted large quantities of heat away from the melt in the furnace with the heat flowing generally from the melt axially into the inner end of the mandrel through the complete cross-section of the mandrel to the outer end of the mandrel. Thereafter, being evenly distributed over the mandrel surface, the heat flow passes radially into the solidifying tube surrounding the mandrel and thence into the mold outside the tube into the cooling means. Because of this large heat loss, additional heat must be supplied to the furnace as well as additional coolant to the cooling means. Besides increasing fuel costs and required cooling capacity, the high heat flow through the solid mandrel delays the cooling of the cast tube thereby reducing the casting speed, i.e., the linear rate of production of cast tubing.

In addition, with this heat flow distribution resulting from the use of a solid mandrel, it is not possible over a long period of time to keep the solidification zone of the cast tube at the same point between the inner and outer ends of the mold. Thus, for instance, varying temperatures of the melt with resulting changes in the heat flow may cause an outward displacement of the solidification zone and lead to a break-out of the melt through the outer end of the mold.

The even distribution of heat flow over the entire mandrel surface also may have an adverse effect on the metallurgical changes which occur during the solidification process as, for example, on the graphite formation when casting iron.

Accordingly, it is an object of this invention to reduce the rate of heat lost through the mandrel in apparatus for continuous casting of tubes.

It is another object of the invention to control the heat flow through the mandrel so that solidification takes place in a predetermined zone between the inner and outer ends of the mold.

It is another object of the invention to provide apparatus for the continuous casting of tubes in which the heat flow from the mandrel via the cast tube into the cooling device takes place mainly in the predetermined solidification zone.

SUMMARY OF THE INVENTION

Briefly, the invention provides apparatus for continuous casting of tubes by means of an elongated wall defining the hollow mold and coaxial inner core mandrel connected to a furnace for supplying molten metal in which the mandrel is hollow for a portion of its length, with the thickness of the wall defining the hollow portion or cavity progressively decreasing in the direction of withdrawal of the cast tube.

This hollow mandrel design makes it possible in a simple manner to establish both the distribution and also the magnitude of the heat flow in such a way that most of the heat from the mandrel passes into the cooling device in the solidification zone, because the narrowing of the heat conductive cross-section along the mandrel leads to a concentration of the heat flow into the solidification zone. Thereby, no bread-out of the melt can occur, which has a favorable effect on both the economics and operating safety of the apparatus.

By varying the shape of the mandrel cavity according to the invention, the heat transfer into the inner wall of the casting can be influenced to achieve any desired effect on the solidification process such as, for example, on the graphite formation when casting iron. In addition, when casting nonferrous metals, particularly metals having high thermal conductivity, a considerable increase in the casting speed can be achieved by reducing the heat transfer with an appropriately shaped hollow mandrel. Thus, for thin-walled copper tubes speeds up to about 100 cm/min. can be achieved.

These and other objects and advantages of the invention will become more apparent from the following detailed description and appended claims taken in conjunction with the accompanying drawings in which:

The FIGURE schematically represents a vertical section through a part of a continuous casting apparatus according to the invention.

DESCRIPTION OF THE PREFERRED EMBODIMENTS

Referring to the drawing, an elongated hollow mold 1 having a cylindrical core mandrel 2 positioned coaxially therein is mounted at one end in the wall of a holding furnace 3 and extends outwardly therefrom. The mandrel 2 has a support flange at its inner end which fits into a corresponding recess in the mold 1 and has spaced openings 11 for the passage of the molten metal from the furnace 3 into the annular space between the mandrel and mold to form cast tube 8. The direction of withdrawal of the cast metal is indicated by an arrow 9.

The mandrel 2 is hollow for part of its length to define a cavity 5 substantially in the shape of a bell-shaped recess having an increasing cross-sectional area in the direction in which the cast tube 8 is withdrawn from the mold; so that the wall thickness of the mandrel decreases in the direction of withdrawal of the tube 8 from the mold. The heat flow in the mandrel corresponds approximately to the pattern indicated by the broken lines, the solidification zone of the melt being in the region designated as A. It is clear that the reduction of cross-sectional area of mandrel 2 due to cavity 5 not only sharply reduces the surface area of the mandrel available for transferring heat from the melt, thus limiting the amount of heat lost, but also effectively restricts the heat flow substantially to the region A.

The mold 1 is provided with a surrounding cooling means such as jacket 4, through which flows a fluid coolant such as water. A secondary cooling device 10 is connected to the cooling jacket 4. Secondary cooling is achieved by spraying coolants against the tube 8 in the zone 6. Advantageously, the mandrel extends into the secondary cooling area 6 of the casting which provides an additional safeguard against a break-out. The mold 1 and mandrel 2 are of heat-resistant material which cannot be wetted with molten metals.

Instead of holding the mandrel 2 in a recess of the mold by the flange 7 it is also possible to provide a threaded connection between the two parts. The outer surface of the mandrel can be slightly tapered instead of cylindrical, the direction of taper being in the direction of withdrawal of the tube 8. If the mandrel wall is so thin that breaking of the wall must be taken into account, it is possible to provide a number of longitudinally extending rib-like reinforcements on the inside of the endangered wall area. One such reinforcement is indicated by way of example at X. Instead of such rib-like reinforcements on the end of the mandrel it is also possible to insert a disc into the mandrel to reinforce the mandrel wall. Such a disc is shown in part at Y.

It can be advantageous to provide a means of cooling the inner wall of mandrel 2, for example, by inert gas or by a liquid cooling medium. The cooling medium can pass through a channel 16 in the furnace wall, radially through the wall of the mold 1, then through the flange 7 between two adjacent openings 11, and thence into mandrel cavity 5. Bore 16 is indicated partially in broken lines.

As described earlier, the casting 8 is cooled by a flow of coolant through the cooling jacket 4 and additionally, if desired, by the open spray at 6. It can be most advantageous to vary the coolant flow in response to temperature variations occurring during the casting process. For this purpose, temperature sensors such as thermocouples 12 can be arranged at appropriate points 15. These sensors provide amplifier 14 with an electrical signal which is proportional to the temperature at the points 15. The output of amplifier 14 actuates control valve 13 to vary the flow of coolant to the jacket 4 and spray 6. It will be appreciated that the temperature sensors ultrasonic measuring can be used to control flow of coolant to mandrel cavity 5 as well as to the external cooling means.

The foregoing description of the preferred embodiments of the invention is by way of example only and is not intended to limit the scope of the invention as defined by the appended claims.

What I claim is:

1. An apparatus for the continuous casting of tubes from metal of the type having a furnace for containing a molten metal, an elongated hollow mold connected at one end to the furnace for receiving the molten metal, a mandrel disposed within the mold to serve as a core for forming a cast tube in the annular space between the outer surface of the mandrel and the inner surface of the mold, said tube solidifying before emerging from the other end of the mold, and cooling means surrounding the outer surface of the mold to define a solidification zone therebetween, wherein the improvement comprises:

said mandrel being hollow for a portion of its length to define an internal cavity within said mandrel, said cavity within said solidification zone having an

increasing cross-sectional area in the direction in which the cast tube is withdrawn from said mold and said mandrel having a wall thickness within said solidification zone about said cavity progressively decreasing in the direction in which the cast tube is withdrawn from the mold to provide a narrowing heat conductive cross-section for concentration of the heat flow into the solidification zone.

2. An apparatus in accordance with claim 1 wherein the hollow portion of the mandrel has approximately the shape of a bell, the opening of which faces said other end of the mold.

3. An apparatus in accordance with claim 1 wherein the outer surface of the mandrel is tapered inwardly in the direction in which the cast tube is withdrawn from the mold.

4. An apparatus in accordance with claim 1 wherein the cooling means surrounding the mold comprises a jacket having circulating coolant supplied thereto and means connected to said jacket for spraying a portion of said circulating coolant on the cast tube as it emerges from the other end of the mold and said mandrel extends beyond the end of the mold to support the tube in the region being cooled by said spray.

5. An apparatus in accordance with claim 4 which comprises

means positioned adjacent the cast tube in the mold for providing an electrical signal in response to changes in temperature of the cast tube and

flow control means responsive to said electrical signal for varying the amount of coolant circulating to said jacket to counteract the temperature changes of the cast tube.

6. An apparatus in accordance with claim 1 which comprises means for conducting a cooling fluid to the hollow portion of said mandrel for cooling the mandrel.

7. An apparatus in accordance with claim 6 wherein the cooling fluid is an inert gas.

8. An apparatus in accordance with claim 1 wherein said mandrel includes at least one longitudinally rib-like reinforcement on the inside wall of said mandrel.

9. An apparatus in accordance with claim 1 which further includes a reinforcing disc inserted in the mouth of said mandrel for reinforcing the wall of said mandrel.

10. The combination of

a stationary elongated hollow mold;

a cooling means surrounding said mold; and

a mandrel disposed within said mold to define a stationary annular space therebetween for a continuous casting of a metal tube therein, said mandrel having a cavity formed therein with an increasing cross-sectional area in the direction in which the metal tube is withdrawn from said mold and a wall defining said cavity said wall having a progressively decreasing thickness to the end of said wall in said direction.

11. The combination as set forth in claim 10 wherein said mandrel is fixedly secured in said mold at an end opposite said cavity.

12. The combination as set forth in claim 10 wherein said wall has a cylindrical outer surface.

13. The combination as set forth in claim 10 wherein said mandrel is of a length at least equal to the length of said mold and wherein said mold and same mandrel extend in said direction from a common transverse

5

6

plane located at one end of each said mold and said mandrel.

includes a first portion of spherical shape with the smallest spherical radius thereof within the plane of said cooling means.

14. The combination as set forth in claim 2 wherein said bell shape of said hollow portion of said mandrel

* * * * *

5

10

15

20

25

30

35

40

45

50

55

60

65

UNITED STATES PATENT OFFICE
CERTIFICATE OF CORRECTION

Patent No. 3,734,166 Dated May 22, 1973

Inventor(s) ALFRED J. WERTLI

It is certified that error appears in the above-identified patent and that said Letters Patent are hereby corrected as shown below:

Column 2, line 4, delete "wall defining the".

Column 4, line 50, before "mandrel" insert "--stationary--".

Column 4, line 50-51, delete "stationary".

Signed and sealed this 26th day of November 1974.

(SEAL)
Attest:

McCOY M. GIBSON JR.
Attesting Officer

C. MARSHALL DANN
Commissioner of Patents

UNITED STATES PATENT OFFICE
CERTIFICATE OF CORRECTION

Patent No. 3,734,166 Dated May 22, 1973

Inventor(s) Alfred J. Wertli

It is certified that error appears in the above-identified patent and that said Letters Patent are hereby corrected as shown below:

Column 2, line 18, "bread" should be -- break -- .

Column 3, line 45, delete "ultrasonic measuring " .

Column 4, line 50, before "mandrel" insert --stationary--.

Signed and sealed this 25th day of December 1973.

(SEAL)

Attest:

EDWARD M. FLETCHER, JR.
Attesting Officer

RENE D. TEGTMEYER
Acting Commissioner of Patents