

(19) **DANMARK**

(10) **DK/EP 2877779 T3**



Patent- og  
Varemærkestyrelsen

(12) **Oversættelse af  
europæisk patentskrift**

- 
- (51) Int.Cl.: **F 21 V 31/00 (2006.01)** **F 21 V 17/00 (2006.01)** **F 21 V 29/00 (2015.01)**
- (45) Oversættelsen bekendtgjort den: **2020-07-13**
- (80) Dato for Den Europæiske Patentmyndigheds bekendtgørelse om meddelelse af patentet: **2020-05-06**
- (86) Europæisk ansøgning nr.: **13823052.9**
- (86) Europæisk indleveringsdag: **2013-07-26**
- (87) Den europæiske ansøgnings publiceringsdag: **2015-06-03**
- (86) International ansøgning nr.: **US2013052235**
- (87) Internationalt publikationsnr.: **WO2014018846**
- (30) Prioritet: **2012-07-26 US 201261675859 P**
- (84) Designerede stater: **AL AT BE BG CH CY CZ DE DK EE ES FI FR GB GR HR HU IE IS IT LI LT LU LV MC MK MT NL NO PL PT RO RS SE SI SK SM TR**
- (73) Patenthaver: **Signify North America Corporation, 200 Franklin Square Drive, Somerset, NJ 08873, USA**
- (72) Opfinder: **GRAJCAR, Zdenko, 80 Luce Line Ridge, Orono, Minnesota 55359, USA**
- (74) Fuldmægtig i Danmark: **Plougmann Vingtoft A/S, Strandvejen 70, 2900 Hellerup, Danmark**
- (54) Benævnelse: **INTEGRERET KREDSLØBSMODULÆRBELYSNING**
- (56) Fremdragne publikationer:  
**EP-A1- 2 383 508**  
**WO-A1-2009/077177**  
**KR-A- 20100 108 797**  
**KR-A- 20120 031 277**  
**US-A1- 2007 041 220**  
**US-A1- 2011 204 780**  
**US-A1- 2011 241 559**  
**US-A1- 2012 008 331**



# DESCRIPTION

## BACKGROUND

**[0001]** This disclosure relates to lighting assemblies. More specifically this disclosure relates to methods and apparatus involving lighting integrated with a conduit.

**[0002]** Lighting can be an important consideration in some applications. In commercial or residential lighting, for example, various types of lighting systems have been commonly used for general illumination. For example, common lighting systems that have been used include incandescent or fluorescent lamps.

**[0003]** More recently, LEDs (light emitting diodes) are becoming widely used devices capable of illumination when supplied with current. Typically, an LED is formed as a semiconductor diode having an anode and a cathode. In theory, an ideal diode will only conduct current in one direction. When sufficient forward bias voltage is applied between the anode and cathode, conventional current flows through the diode. Forward current flow through an LED may cause photons to recombine with holes to release energy in the form of light.

**[0004]** The emitted light from some LEDs is in the visible wavelength spectrum. By proper selection of semiconductor materials, individual LEDs can be constructed to emit certain colors (e.g., wavelength), such as red, blue, or green, for example.

**[0005]** In general, an LED may be created on a conventional semiconductor die. An individual LED may be integrated with other circuitry on the same die, or packaged as a discrete single component. Typically, the package that contains the LED semiconductor element will include a transparent window to permit the light to escape from the package.

**[0006]** As the cost of manufacturing LED lighting assemblies continues to decrease, real world applications increase. For example, LED lighting assemblies are beginning to be used in barn settings where preexisting electrical conduits exist to provide lighting from more traditional lighting assemblies. There is a need for LED lighting assemblies that will attach and connect to preexisting electrical conduits such that the lighting assemblies may easily replace existing lighting. Further a need exists for such lighting assemblies to be water tight for high pressure cleaning operations that occur in such facilities.

**[0007]** Therefore a principle object of the present disclosure is to provide an integral conduit modular lighting assembly that is interchangeable with preexisting electrical conduit;

**[0008]** Another object of the present disclosure is to reduce manufacturing costs associated with making an integral conduit modular lighting assembly.

**[0009]** US 2011/0204780 A1 discloses a method for forming a light source including receiving an LED light module having a plurality of LEDs on a silicon substrate coupled to a flexible printed circuit and bonding the LED light module directly to a heat-sink with a thermal adhesive.

**[0010]** US 2011/0241559 A1 discloses an apparatus and associated methods involving a light module adapted to mount to an open face of a conduit body. The light module may include an electrical interface for making operative electrical connection to conductors disposed within the conduit body.

#### **BRIEF SUMMARY OF THE INVENTION**

**[0011]** An invention is set out in the independent claims. In an aspect of the disclosure, an integral conduit modular lighting system that has a light board having circuitry that is secured to a heat sink with an adhesive layer. The heat sink not only provides heat conveying advantages, but also provides surfaces for the adhesive layer and a gasket in order to securely connect the lighting system to a preexisting conduit body such that the lighting system will withstand a high pressure wash without leakage to the board. Further the lighting system is adapted to attach to preexisting electrical conduit bodies to provide easy and inexpensive installation of the modular lighting system.

#### **BRIEF DESCRIPTION OF THE DRAWINGS**

##### **[0012]**

Fig. 1 is a perspective view of an illustrative free range-style chicken coop installation with an exemplary embodiment of an integral conduit modular (ICM) lighting system;

Fig. 2 is a front perspective view of an integral conduit modular lighting system with the lens removed;

Fig. 3 is a back perspective view of an integral conduit modular lighting system;

Fig. 4 is a schematic circuit diagram of an integral conduit modular lighting system;

Fig. 5A is a front plan view of an integral conduit modular lighting system;

Fig. 5B is a front plan view of a conduit body and integral conduit modular lighting system;

Fig. 6 is a front plan view of an integral conduit modular lighting system secured to a conduit body; and

Fig. 7 is a front plan view of a substrate having electrical components thereon.

## DETAILED DESCRIPTION OF A PREFERRED EMBODIMENT OF THE INVENTION

**[0013]** FIG. 1 shows a perspective view of an illustrative free range-style chicken coop installation with an exemplary embodiment of an integral conduit modular (ICM) lighting system. In this example, a coop installation 100 includes a frame 105 and a number of bays 105 disposed on rows of three bays on both a lower level and an upper level. In an illustrative example of egg production, a number of chickens may spend at least part of their time in the bays where they may receive food, air, water, and they may also deposit eggs. In some coop installations, the eggs may roll down a ramp (not shown) to an egg collection/conveyer system (not shown).

**[0014]** On the lower level of the coop installation 100, an interior volume of each of the bays 110 is illuminated by an integral conduit modular lighting system that includes sections of electrical conduit 115 connected to corresponding ports of a number of integral light modules (ILMs) 120. Each of the ILMs 120 includes a conduit body 125 and a light engine 130 attached to an open longitudinal face of the conduit body 125. For the depicted lower level of bays 110, the conduit 115 and ILMs 120 are positioned to direct from a peripheral position outside the frame 105 and toward a central midline of the coop installation 100. The ILMs 120 are positioned substantially in an upper portion of the bays 110 of the lower level to promote sufficient illumination of the water and feed facilities within each of the bays 105. The ILM 120 may advantageously provide substantial illumination of food and water access facilities in the bays 110 while the bays are substantially populated with chickens.

**[0015]** By way of example, and not limitation, and in various implementations, the conduit 115 and/or the conduit body 125 may be of a standard or conventional type which may be used by electricians, for example, to install electrical wiring. In the depicted example, the conduit body 125 may be of the type of conduit body for rigid conduit that is commercially available in standard sizes, for example, from Thomas & Betts Corporation of Tennessee.

**[0016]** On the upper level of the coop installation 100, an interior volume of each of the bays 110 is illuminated by an integral conduit modular lighting system that includes sections of electrical conduit 140 connected to corresponding ports of a number of integral light modules (ILMs) 150. Each of the ILMs 150 includes a conduit body 155 and oppositely directed light engines 160a, 160b attached to opposing open longitudinal faces of the conduit body 155. For the depicted upper level of bays 110, the conduit 140 and the ILMs 150 are positioned to direct light outward from a central position along the midline of the coop installation 100. Each of the ILMs 150 in the upper level are positioned substantially in an upper portion of the bays 110 to provide sufficient illumination of the water and feed facilities within the bays 110 on either side of the midline of the coop installation 100. The ILM 150 may advantageously provide substantial illumination of food and water access facilities in the bays 110 while the bays are substantially populated with chickens.

**[0017]** In one embodiment as best shown in Fig. 2 the ILM 150 includes a light engine 160 that has a heat sink 165 that in one embodiment is a sheet of metal where first openings 170 are disposed through the heat sink 165 to align with openings on the conduit body 155. A second opening 175 is also disposed through the heat sink 165 to provide a pathway for wire connectors 180 that can include leads 185 for electrical connection to wiring within the conduit 140 to power the ILM 150.

**[0018]** A gasket 190 is secured to a first side 195 of the heat sink 165 and is of size and shape to mate with the perimeter of the conduit body 155. In this manner a sealing connection is formed between the ILM 150 and conduit body 155 when fasteners are used to secure the ILM 150 to the conduit. Specifically the gasket 190 is made of a flexible material that deforms when pressed against the conduit body 155 to form a water tight seal between the heat sink 165 and conduit body 155.

**[0019]** On a second side 200 of the heat sink 165 an adhesive layer 205 is provided that in a preferred embodiment is a heat conducting epoxy that not only adheres or secures a light board 210 to the heat sink 165, but also conveys heat from the light board 210 to the heat sink 165. The adhesive layer 205 can be any size and can be of size and shape to have openings disposed therethrough to accommodate fasteners used to connect the ILM 150 to the conduit body 155.

**[0020]** The light board 210 is a substrate that can be made out of any material including ceramic material or can also be a PCB, present a semiconductor die or the like such that the substrate can hold and electrically connect a plurality of electrical components 215. These electrical components 215 are best shown in the circuit diagram of Fig. 4.

**[0021]** In particular the circuit 220 on the board 210 receives power from an AC input 225. A fuse 230 is provided for circuit protection along with a metal-oxide varistor (MOV) 232 or zener diode before the AC current flows to a rectifier 235. Once rectified that current flow to a plurality of LEDs 240 and driving elements 245 such as transistors 250 used in combination with resistors 255 to form a bypass circuit 260 to control the operation of the LEDs 240. In one embodiment the transistors are MOSFETs, while in other embodiments the transistors are IGFETs or other similar transistors known in the art. In this embodiment the electrical components 215 are arranged as shown in Fig. 2 with the plurality of LEDs 240 centrally located on the board 210 with other electrical components 215 such as the rectifier 235 and driving elements 245 on the perimeter of the board 210 surrounding the LEDs to provided enhanced lighting diffusion.

**[0022]** A lens element 265 is secured to the adhesive layer 205 and surrounds the board 210. In this manner the lens 265 provides additional water tight protection to the board 210 to ensure the circuitry 220 on the board does not get wet during high pressure cleaning of the lighting as is common in an agricultural or barn setting. In addition the lens 265 is made of a transparent material to allow the light from the LEDs to be diffused throughout the dwelling or area containing the lighting assembly. In one embodiment the lens 265 is made of a plastic

material. The lens 265 also has openings 270 disposed therethrough that align with the openings in the adhesive layer 205, heat sink 165 and conduit body 155 so that fasteners 275 can be used to secure the ILM 150 to the conduit body 155.

**[0023]** Thus provided is a ILM 150 that is easy and inexpensive to manufacture. The ILM can be used to replace existing lighting in dwellings such as barns or other agricultural dwellings by using existing electrical conduits 115. Specifically, the ILM 150 has wire connectors 180 that connect to the existing conduit wiring and a structure designed to sealing secure to an existing conduit body 155. In particular, as a result of the use of a gasket 190, adhesive layer 205 and lens 265 the board 210 is sealed from exterior conditions preventing shortages when the ILMs 150 are washed with high pressure water. Thus, at the very least all of the objects have be met.

## **REFERENCES CITED IN THE DESCRIPTION**

This list of references cited by the applicant is for the reader's convenience only. It does not form part of the European patent document. Even though great care has been taken in compiling the references, errors or omissions cannot be excluded and the EPO disclaims all liability in this regard.

### **Patent documents cited in the description**

- [US20110204780A1 \[0009\]](#)
- [US20110241559A1 \[0010\]](#)

**Patentkrav****1.** Indretning til belysning, omfattende:

et kredsløbslegeme (155);

en lysplade (210);

5 elektrisk kredsløb (220) på lyspladen, idet lyspladen har en første side (195) og en anden side (200), der definerer modstående plane overflader; et lysmotormodul, der omfatter et array af lyskilder, der er anbragt på den første side af lyspladen med drivkredsløb (220), der er konfigureret til at forsyne elektrisk excitering til arrayet af lyskilder, hvor nævnte anden side  
10 indgriber med et klæbelag (205) for at fastgøre lysmotormodulet til en varmeafleder (165);

en pakning (190), der er fastgjort til varmeaflederen, hvor, når lysmotormodulet er sikkert monteret på kredsløbslegemet, pakningen indgriber med kredsløbslegemet for at forhindre vand i at trænge ind i

15 kredsløbslegemet; og

et linsemodul (265), der har en indre linseoverflade, der indgriber med og er fastgjort til klæbelaget for at tilvejebringe en vandtæt tætning for at forhindre at vand trænger ind på lyspladen og ind på det elektriske kredsløb.

20

**2.** Indretning ifølge krav 1 yderligere omfattende mindst et monteringshul til sikker montering af lysmotormodulet i en fast position i forhold til kredsløbslegemet.

25 **3.** Indretning ifølge krav 1, hvor kredsløbslegemet omfatter en industriel standard elektrisk forgreningsdåse.

**4.** Indretning ifølge krav 1, hvor de elektriske exciteringssignaler omfatter et vekselstrøms-(AC)-signal.

30

**5.** Indretning ifølge krav 1, hvor arrayet af lyskilder er lysudsendende dioder.

**6.** Indretning ifølge krav 1, hvor lyspladen er en trykt kredsløbsplade.

**7.** Fremgangsmåde til at installere en indretning til at belyse i en hønselhusinstallation (100) for at forhindre strømning af vand i indretningen, hvor fremgangsmåden omfatter:

- 5 at tilvejebringe et elektrisk kredsløb (115), der er forbundet til tilsvarende porte i et integreret lysmodul (120), der har et kredsløbslegeme (125), hvor nævnte integrerede lysmodul yderligere omfatter et array af lyskilder, der er anbragt på en lysplade (210), der har en første side (195) og en anden side (200), der definerer modstående plane overflader;
- 10 at klæbe lyspladen til en varmeafleder (165) med et klæbelag (205);
- at fastgøre en pakning (190) til en side af varmeaflederen modsat lyspladen;
- at fastgøre en linse (265) til varmeaflederen mod klæbelaget for at forsegle lyspladen fra vand; og
- 15 at montere varmeaflederen til kredsløbslegemet for at forhindre vand i at trænge ind i kredsløbslegemet.

**8.** Fremgangsmåde ifølge krav 7 yderligere omfattende trinnet med at presse pakningen mod kredsløbslegemet for at tilvejebringe en vandtæt tætning.

- 20 **9.** Fremgangsmåde ifølge krav 8, hvor pakningen er fremstillet af et fleksibelt materiale som deformeres, når pakningen presses mod kredsløbslegemet.

**10.** Fremgangsmåde ifølge krav 8, hvor arrayet af lyskilder er lysudsendende dioder.

25

# DRAWINGS

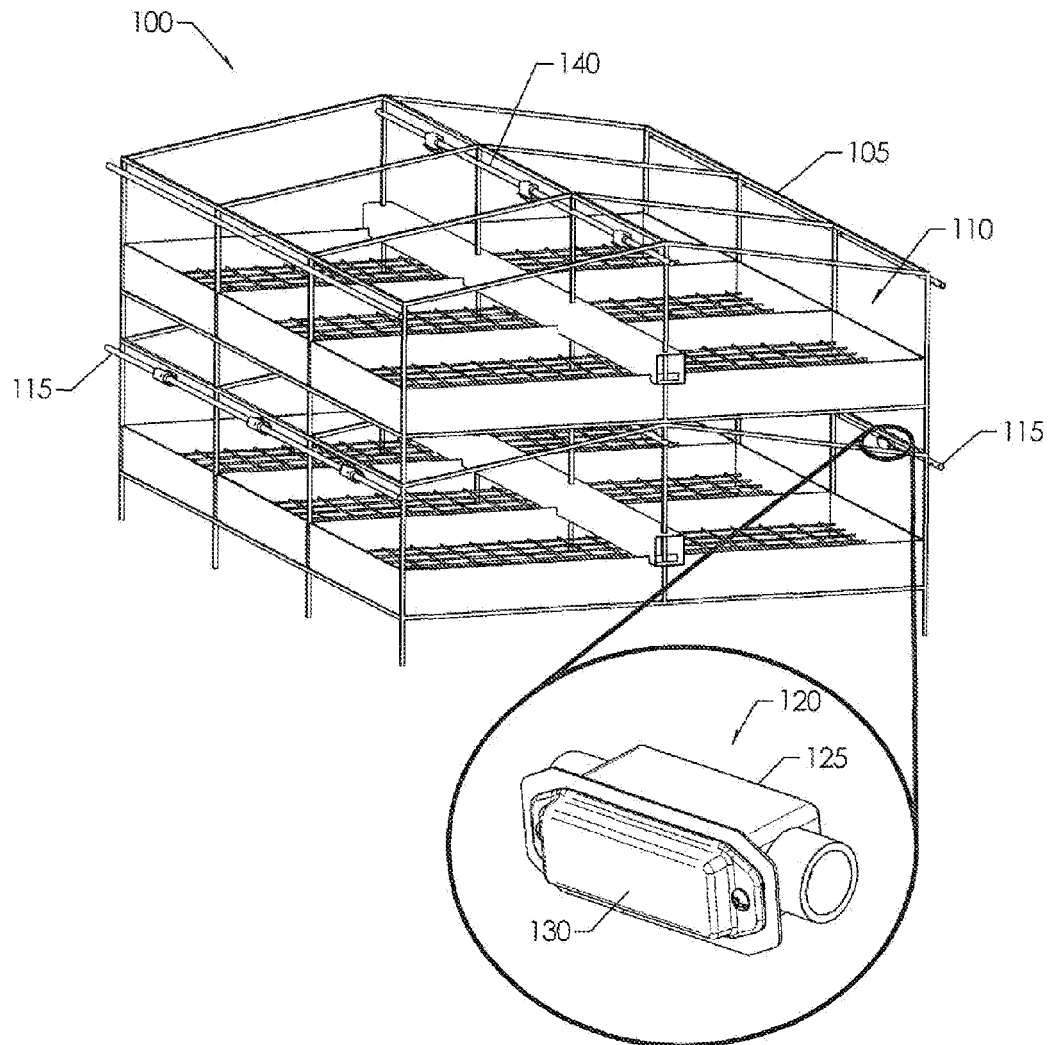

FIG. 1

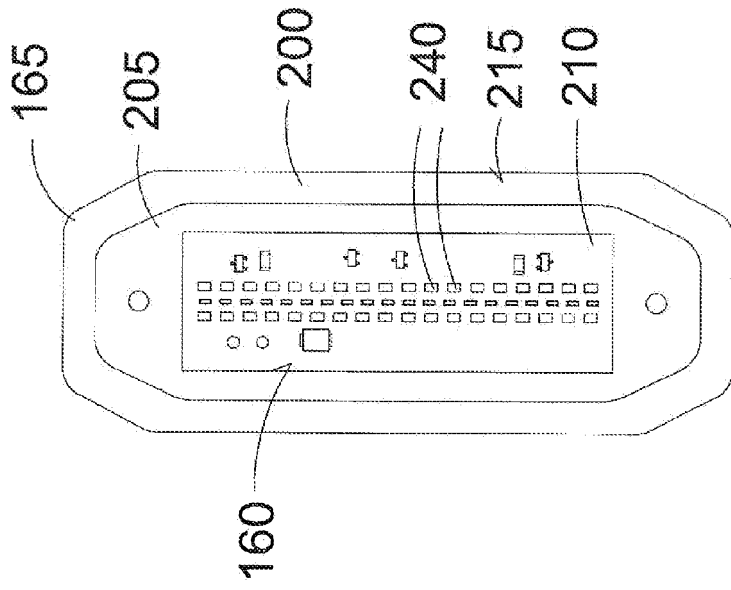

FIG. 2

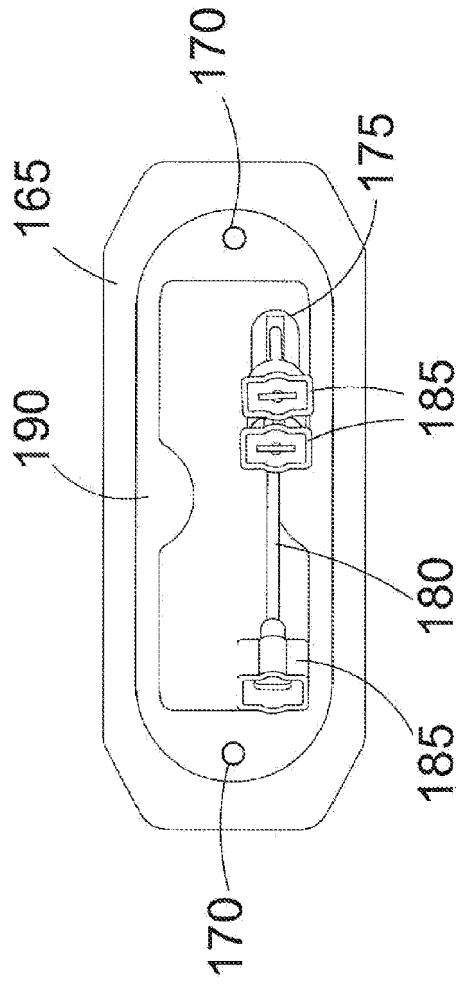

FIG.3

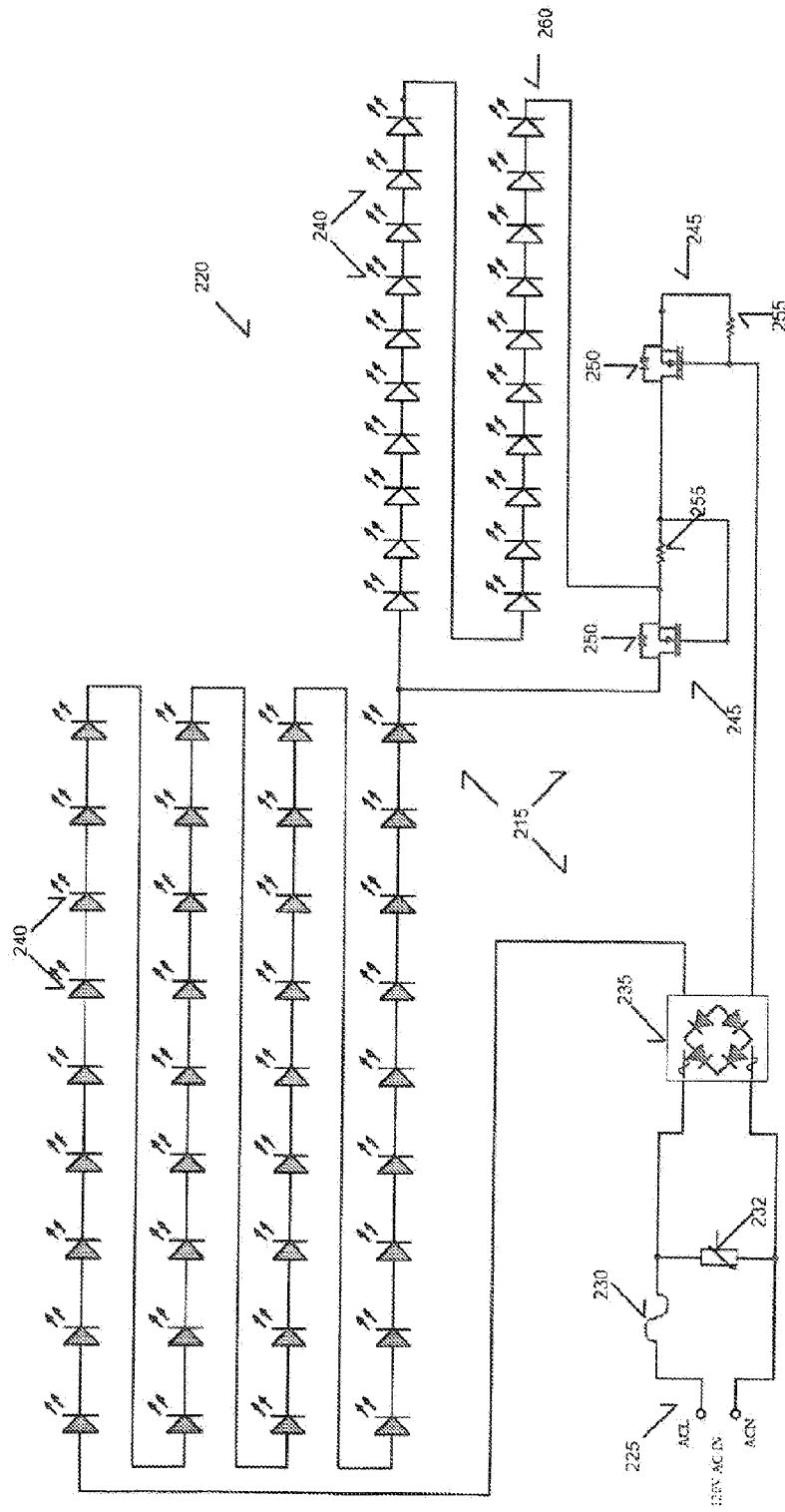

FIG. 4

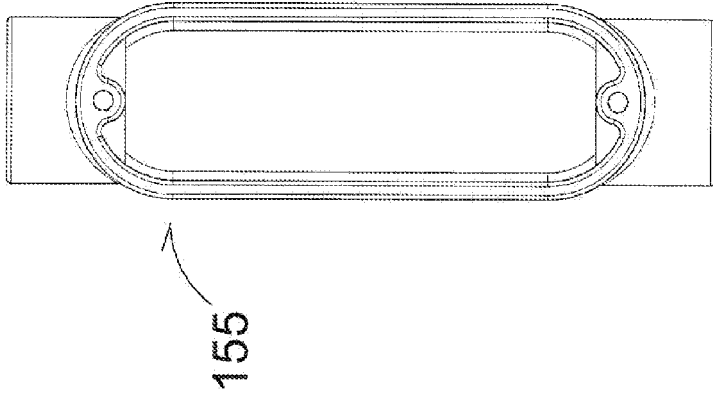

FIG. 5b

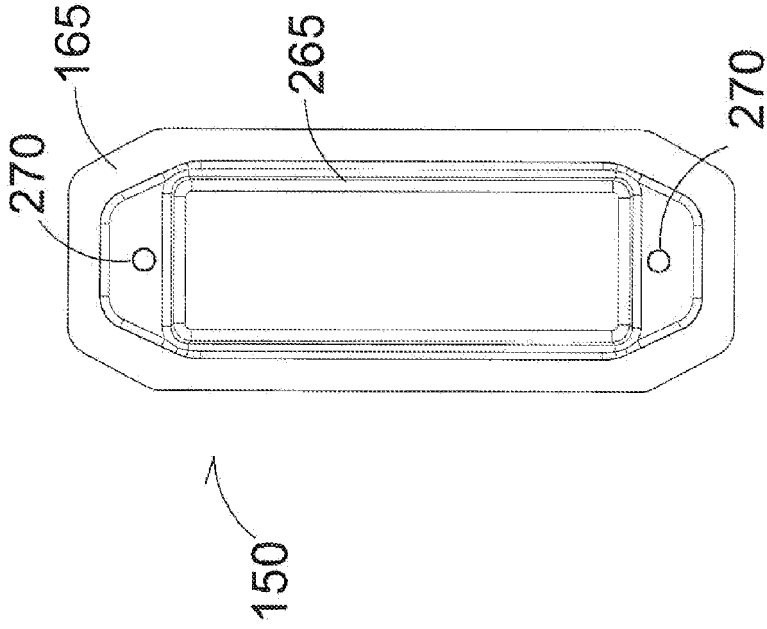

FIG. 5a

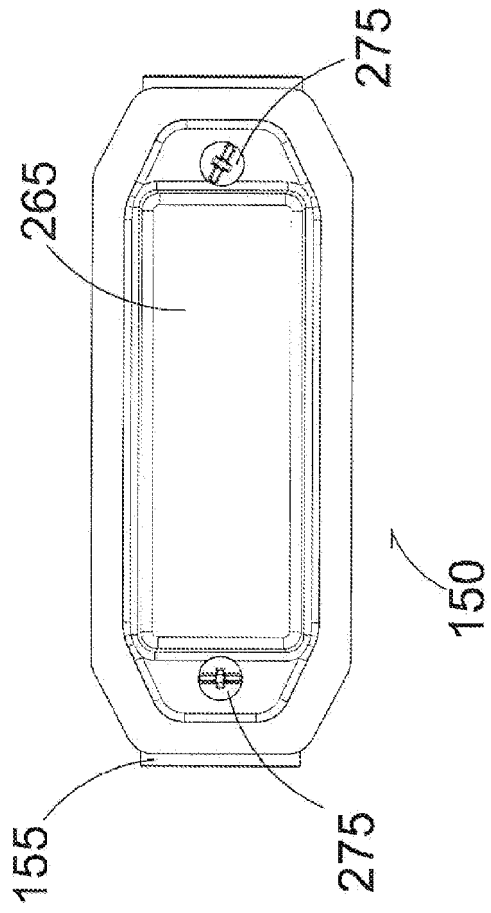

FIG.6

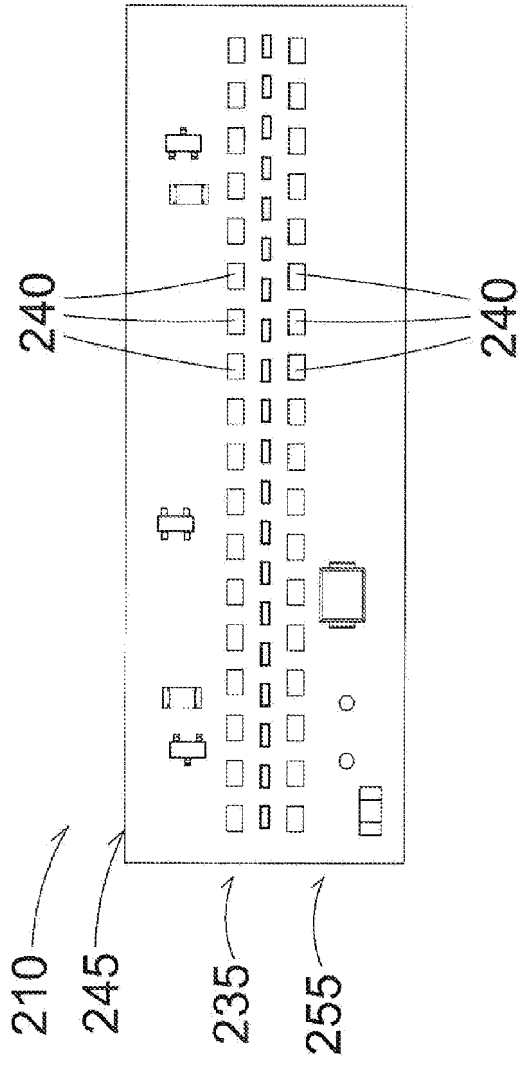

FIG.7