

**(12) STANDARD PATENT**  
**(19) AUSTRALIAN PATENT OFFICE**

(11) Application No. **AU 2014201219 B2**

(54) Title  
**Electronic device having detachable battery pack**

(51) International Patent Classification(s)  
**H05K 5/00** (2006.01)                      **H02J 7/00** (2006.01)

(21) Application No: **2014201219**                      (22) Date of Filing: **2014.03.05**

(30) Priority Data

(31) Number	(32) Date	(33) Country
<b>10-2013-0025394</b>	<b>2013.03.11</b>	<b>KR</b>

(43) Publication Date: **2014.09.25**

(43) Publication Journal Date: **2014.09.25**

(44) Accepted Journal Date: **2015.11.26**

(71) Applicant(s)  
**SAMSUNG ELECTRONICS CO., LTD.**

(72) Inventor(s)  
**CHOI, Jong-Min;CHUN, Hong-Moon**

(74) Agent / Attorney  
**Griffith Hack, GPO Box 1285, Melbourne, VIC, 3001**

(56) Related Art  
**US 2008/0193829**  
**FR 2835681**  
**US 5317247**  
**US 2010/0143793**  
**US 2008/0146293**

**ABSTRACT OF THE DISCLOSURE**

An electronic device may include a battery pack and a battery pack mount portion. The battery pack may be mounted or secured within the battery pack mount portion in such a way that the battery pack does not influence or apply pressure to neighboring structures. For examples, the battery pack may include at least one eat protrusion that is received within at least one recess formed in the battery pack mount portion.

2014201219 05 Mar 2014

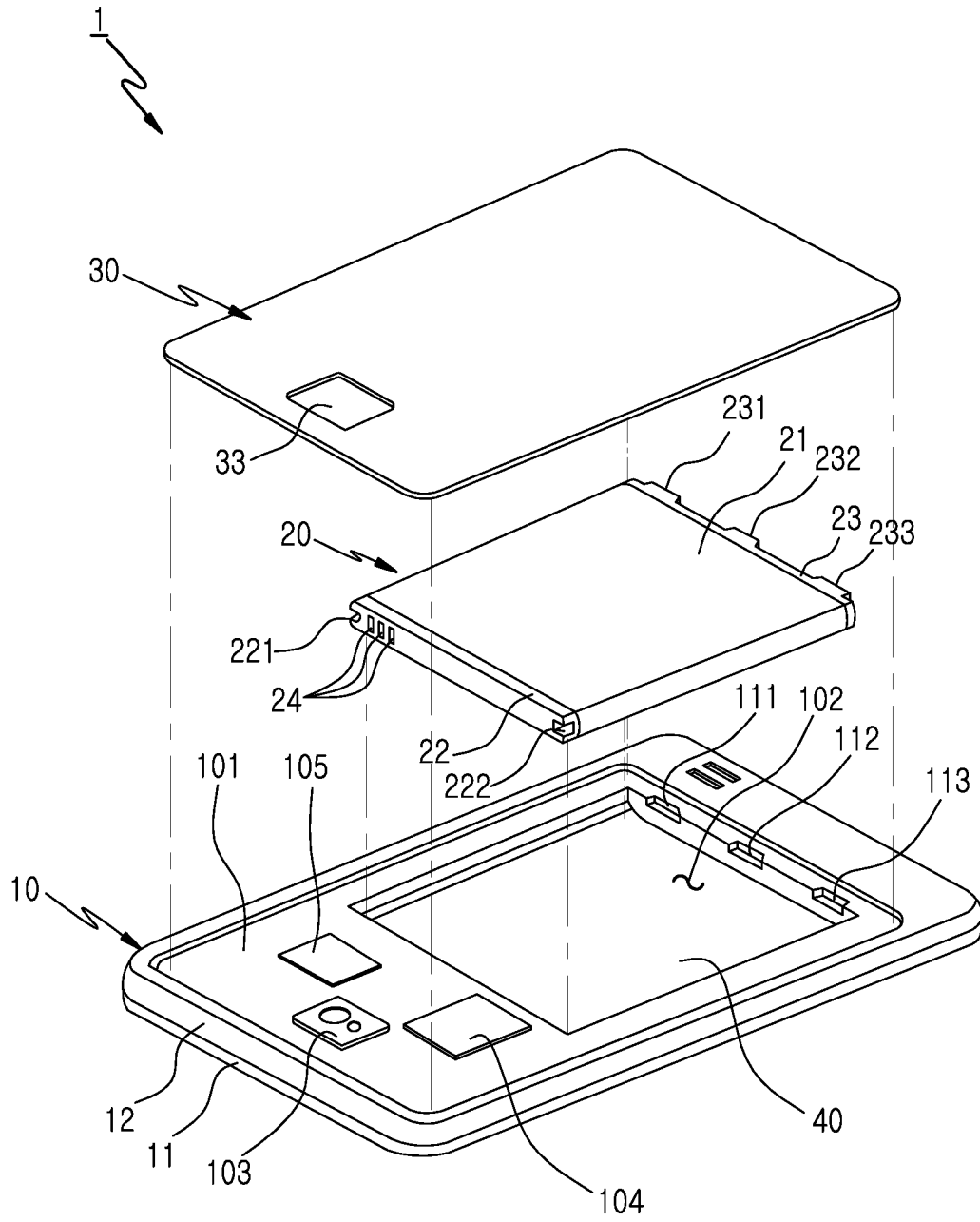

FIG.1

## ELECTRONIC DEVICE HAVING DETACHABLE BATTERY PACK

### 1. Field

The present disclosure relates to an electronic device having a detachable battery  
5 pack.

### 2. Background

As multimedia technology continues to develop, the functionality of electronic  
devices is increasing. Generally, there has been a convergence of technology such that a  
10 single device may perform functions that were previously performed by several different  
standalone electronic devices.

Mobile terminals are electronic devices that are commonly known as "smartphones."  
Mobile terminals have entered the mainstream of daily life. These mobile terminals often  
15 include a large-sized touch type display module and a mega-pixel camera module. The  
inclusion of such components enable a smartphone to not only provide a communication  
function, but also to provide other functions such as the ability to photograph pictures and  
record motion pictures. Mobile terminals may also reproduce multimedia contents such as  
music, moving pictures, and the like. They may also provide access a network to allow a  
20 user to browse the web or internet. As the performance of mobile terminals, *e.g.*, processor  
performance, continues to improve, the functionality of smartphones is increasing such that  
the primary function of these devices is no longer just communication.

The above-described electronic devices require a power supply means, such as a  
25 battery pack, which is capable of providing power for all of the above-described functions.  
Often, a battery pack is detachably installed within the electronic device, and may be  
separated from the electronic device and charged using a separate adapter for charging.

Generally, the increase in the functionality of electronic devices has caused a  
30 corresponding increase in the power requirements for such devices to operate. These power  
requirements have led to battery packs having a greater capacity to store power. As the  
capacity of power packs increases, the physical size of the battery pack has also increased. In  
the case of a mobile terminal, the battery pack typically occupies sixty (60) percent or more  
of the space within the mobile terminal. As the power requirements of electronic devices

continue to increase, the battery packs that power these devices are likely to become physically larger such that the space within the electronic devices that is occupied by the battery packs will correspondingly become greater.

When a battery pack having a large volume is mounted inside an electronic device, it is desirable that its position within the electronic device is maintained without influencing or being influenced (*e.g.*, applying excessive forces) by neighboring structures within the electronic device.

### SUMMARY OF INVENTION

In an embodiment, an electronic device may include a battery pack having a relatively large volume and a high capacity.

In another embodiment, an electronic device may include a battery pack that is configured such that it is not deformed (*e.g.*, by external forces acting upon the electronic device or between the battery pack and its neighboring components) after it is mounted in the electronic device.

In yet another embodiment, an electronic device may include a battery pack configured such that it is not deformed (*e.g.*, by external forces acting upon the electronic device or between the battery pack and its neighboring components) after it is mounted without separate limitation in design or extension of a space.

In a still further embodiment, an electronic device may include a battery pack that is easily detachable from the electronic device.

In yet a further embodiment, an electronic device may include a battery pack configured to prevent floating or movement of the mounted battery pack relative to other components of the electronic device and/or also to prevent destruction of the battery pack

In another embodiment, an electronic device may include a case frame having a battery pack mount portion and a battery pack mounted in the battery pack mount portion. The battery pack may be used as a power supply means. One or more seat protrusion may be formed to protrude to an outer direction from at least one end of the battery pack. A recess may be

formed in the battery pack mount portion. The seat protrusion may be seated within the recess. The seat protrusion may be hooked at the recess in such a way that it is seated in the recess such that the battery pack may not pressurize a backside of the battery pack mount portion.

5 An embodiment of the present invention also provides an electronic device comprising:

a battery pack;

a case frame having an opening forming a battery pack mount portion in which the battery pack is mounted; and

10 a sheet plate blocking the opening at a backside of the battery pack mount portion;

wherein the battery pack comprises:

a battery cell; and

15 first and second support bodies supporting the battery cell on opposing ends of the battery cell;

wherein the first support body includes either a recess or protrusion; and

wherein one or more seat protrusions protrude from the second support body to an outer direction;

wherein the battery pack mount portion comprises:

20 one or more seat recesses in which the one or more seat protrusions are seated; and

a protrusion or recess corresponding to the first support body recess or protrusion; and

25 wherein when the battery pack is mounted the one or more seat protrusions are supported by the seat recesses, and the first support body recess or protrusion is coupled to the corresponding protrusion or recess.

### BRIEF DESCRIPTION OF THE DRAWINGS

30 The above and other aspects, features and advantages of certain exemplary embodiments of the present invention will be more apparent from the following description taken in conjunction with the accompanying drawings in which:

FIG. 1 is an exploded perspective view of an electronic device having a battery pack

according an embodiment of the present disclosure;

FIG. 2 is a perspective view of a sheet plate is shown relative to an upper case frame of FIG. 1;

FIG. 3 is a cross-sectional view of the electronic device FIG. 1 shown with the battery pack mounted therein;

FIG. 4 is a cutaway perspective view of FIG. 1;

FIG. 5 is a plan view of a portion of the electronic device of FIG. 1;

FIG. 6 is a cutaway perspective view of a portion of the electronic device of FIG. 1 shown with the battery pack of FIG. 1 mounted therein;

FIG. 7 is a perspective views illustrating the battery pack of FIG. 1; and

FIG. 8 is a cutaway perspective view of a battery pack according to another embodiment of the present disclosure.

#### DETAILED DESCRIPTION

The following description with reference to the accompanying drawings is provided to assist in a comprehensive understanding of exemplary embodiments of the invention as defined by the claims and their equivalents. It includes various specific details to assist in that understanding but these are to be regarded as merely exemplary. Accordingly, those of ordinary skill in the art will recognize that various changes and modifications of the embodiments described herein can be made without departing from the scope and spirit of the invention. Also, descriptions of well-known functions and constructions are omitted for clarity and conciseness.

The terms and words used in the following description and claims are to be broadly construed in light of the present specification and are not to be limited to any particular dictionary definition as they are merely used by the inventor to enable a clear and consistent understanding of the invention. Accordingly, it should be apparent to those skilled in the art that the following description of exemplary embodiments of the present invention are provided for illustration purpose only and not for the purpose of limiting the invention as defined by the appended claims and their equivalents. Throughout the accompanying drawings, like reference numerals will be understood to refer to like parts, components, and structures.

It is to be understood that although a mobile terminal having a display module has been illustrated and explained in describing embodiments of the present invention, the presently described invention is not limited to a mobile terminal but is applicable to electronic devices more generally. For example, the present invention is applicable to various electronic devices having a detachable battery pack such as a Personal Digital Assistant (PDA), a laptop computer, a mobile phone, a smartphone, a netbook, a Mobile Internet Device (MID), an Ultra Mobile Personal Computer (UMPC), a tablet PC, a navigation, an MP3 player, etc.

In an embodiment, an electronic device may include a case frame having a battery pack mount portion and a battery pack mounted in the battery pack mount portion. The battery pack may be used as a power supply means. One or more seat protrusion may be formed to protrude to an outer direction from at least one end of the battery pack. A recess may be formed in the battery pack mount portion. The seat protrusion may be seated within the recess. The seat protrusion may be hooked at the recess in such a way that it is seated in the recess such that the battery pack may not pressurize a backside of the battery pack mount portion.

In a still further embodiment, a plurality of seat protrusions may protrude at predetermined intervals to an outer direction from one end of the battery pack.

In yet another embodiment, the seat protrusion may be formed to protrude in a rib shape from a side of the battery pack.

In yet another embodiment, the seat protrusion may be installed at a lower end of the battery pack.

In a still further embodiment, the seat protrusion may be at least one of support bodies formed of an insulating synthetic resin supporting a battery cell of the battery pack.

In a further embodiment, both a left and a right side of the battery pack mount portion may be formed in a bent shape entering in a direction of the battery pack mount portion toward a lower side thereof in order to support both the left and right sides of the battery pack.

In yet another embodiment, a backside of the battery pack mount portion may include at least one of a sheet plate, a plastic sheet, and a conductive tape mounted with a case frame such that it is separable.

5

In another embodiment, the battery pack may include a battery cell, a first support body formed of an insulating synthetic resin that is installed to support the battery cell on one side of the battery cell, and a second support body formed of an insulating synthetic resin that is installed in a direction facing the first support body.

10

In a further embodiment, the seat protrusion may be formed on the second support body.

In another embodiment, concave recesses may be formed in both a left and a right side of the first support body, and protrusions configured to fit in the concave recesses may protrude on a corresponding position of the battery pack mount portion.

15

In a still further embodiment, the battery pack mount portion may have a mount space that is positioned lower relative to a backside of the electronic device.

20

In another embodiment, the battery pack may be mounted in the battery pack mount portion and an upper side of the battery pack may be configured such that it is not higher relative to a backside of the electronic device.

25

In a still further embodiment, the seat protrusion may be configured such that it does not protrude beyond the upper side of the battery pack or the backside of the electronic device when the seat protrusion is seated in the recess.

FIG. 1 is an exploded perspective view illustrating an electronic device 1 having a battery pack 20 according to an embodiment of the present disclosure.

30

Referring to FIG. 1, the electronic device 1 may include a main body 10, a battery pack 20 that is detachably installed in the backside of the main body 10, and a cover 30 mounted in a portion of the backside of the main body 10, which is configured to protect the battery pack 20 and various components within the electronic device 1. In particular, the

cover 30 protects the battery pack 20 by inhibiting or preventing it from being exposed to the outside or detached from the electronic device. An opening 33 may be formed through the cover 30 through which a component (for example, a camera module 103) that is installed in the main body 10 of the electronic device 1 may pass through and exposed to the outside of the electronic device 1.

The main body 10 of the electronic device 1 may include an upper case frame 11 and a lower case frame 12 that are coupled to each other, and may receive various electronic components, which may perform various electronic function, therein. A large-screen display module (not shown) may be installed on the front side of the electronic device 1, and may include a touch sensor for receiving a data input.

A cover mount portion 101 may be formed in the backside of the electronic device 1, and various components may be exposed through the cover mount portion 101. The components that are exposed through the cover mount portion 101 may be detachably installed or operatively coupled to the electronic device 1. These components may include the battery pack 20 and other components such as a Subscriber Identity Module (SIM) card mount portion 104 in which a SIM card is installed, a memory card mount portion 105 in which a small memory card is installed, etc. The electronic device 1 may include the camera module 103, which may be exposed to the outside of the electronic device 1 to allow for photographing or shooting of an object.

Furthermore, the cover mount portion 101 may be configured such that the outer side of the cover mount portion 101 shares a side with the lower case frame 12 of the main body 10 when the cover mount portion 101 is coupled to the main body 10. The cover mount portion 101 may be formed to have a recess having a depth that is substantially the same thickness as the cover 30. Therefore, when the cover 30 is mounted in the lower case frame 12 of the electronic device 1, the cover 30 and the lower case frame 12 may be in the same plane. A plurality of hooking protrusions (not shown) may be formed at predetermined intervals along the edge of the cover 30. A plurality of hooking recesses (not shown) may be formed in the cover mount portion 101 of the main body 10 of the electronic device 1 so that the cover 30 may be fixed in the cover mount portion 101 in such a way that the hooking protrusions are forcibly fit into the hooking recesses.

A battery pack mount portion 102 may have a surface that is positioned along a plane that is lower than that of a surface of the cover mount portion 102. The battery pack 20 may be mounted within a recess that is formed in the cover mount portion 101. A separate sheet plate 40 may space the backside of the battery pack mount portion 102 apart from other components such as the display module. The sides of the battery pack mount portion 102 may support the sides of the battery pack 20.

The battery pack 20 may include a battery cell 21, a first support body 22, and a second support body 23. The first support body 22 and the second support body 23 may support the battery cell 21 at opposing ends thereof. The first and second support bodies 22 and 23 may be formed of an insulator, such as a synthetic resin.

The first support body 22 may include a plurality of terminals 24 that are electrically connected to the battery cell 21 inside the battery pack 20 and exposed to the outside of the battery pack 20. The terminals 24 may be electrically connected to a connector (not shown) installed in the battery pack mount portion 102 of the main body 10. Concave recesses 221 and 222 may be formed at opposing ends of the first support body 22 and coupled to protrusions that are formed in the battery pack mount portion 102 of the main body 10 to guide mounting of the battery pack 20 and to prevent detachment of the battery pack 20 from the battery pack mount portion 102. The concave recesses 221 and 222 may also or alternatively be formed at opposing ends of the first support body 22. Furthermore, similar recesses (not shown) may also or alternatively be formed at corresponding positions of the battery pack mount portion 102 of the main body 10, and coupled to corresponding protrusions (not shown) formed on the battery pack 20.

According to an embodiment of the present invention, a plurality of seat protrusions 231, 232, 233 may protrude at predetermined intervals from the second support body 23. When the battery pack 20 is mounted in the battery pack mount portion 102 of the main body 10, the seat protrusions 231, 232, 233 may be seated in recesses 111, 112, 113 having a groove shape at corresponding positions along a side of the battery pack mount portion 102. Consequently, when the battery pack 20 is mounted in the battery pack mount portion 102, the protrusions 231, 232, 233 formed in the battery pack mount portion 102 of the main body 10 fit in the concave recesses 111, 112, 113 of the first support body 22. Also, since the plurality of seat protrusions 231, 232, 233 of the second support body 23 are hooked at the

recesses 111, 112, 113 formed in the corresponding positions of the battery pack mount portion 102 of the main body 10, the battery pack 20 does not influence (*e.g.*, apply pressure or force to) the sheet plate 40 disposed on the lower side of the battery pack mount portion 102.

5

The described battery pack mount structure has a different configuration from the conventional battery pack mount structure. In the conventional art, only one side of the battery pack is supported by a battery pack mount portion, and the other side (for example, a second injection direction) is supported by a sheet plate disposed on the lower side of the battery pack mount portion.

10

Therefore, in the conventional art, after the battery pack is mounted in the battery pack mount portion of the main body, the battery pack will strike the sheet plate due to an external pressure or external impulse, which may result in the sheet plate becoming warped and deformed. Consequently, a mount tolerance of the battery pack has to be greater, resulting in the battery pack floating or moving arbitrarily and increasing the potential of a malfunction in electrical connection with the main body occurs.

15

Furthermore, since both the left and right of the battery pack mount portion are conventionally formed to support both sides of the battery pack using an assembly structure of the case frame of the electronic device, the battery pack is designed to be tightly mounted in the battery pack mount portion. The conventional configuration may result in deformation or destruction of the case frame of the electronic device when the volume or size of the battery pack increases, for example, from being fully or overly charged, causing it to press against neighboring structures or components.

20

In contrast, according to an embodiment of the present disclosure, the plurality of seat protrusions 231, 232, 233 are formed on the second support body 23, which is on a side of the battery pack 20, and the protrusions 231, 232, 233 are seated and hooked at the recesses 111, 112, 113 formed in the corresponding positions of the battery pack mount portion 102. Therefore, the first and second support bodies 22 and 23, which are located at upper and lower ends of the battery pack 20, have a self-support structure that is independent of the sheet plate 40. This configuration reduces the likelihood that, the sheet plate 40 will be deformed. Due to this support structure, both the left and right injected structures inside

30

the battery pack mount portion 102 of the case frame 11 of the electronic device 1 supporting both the left and right of the battery pack 20 may be designed to include a marginal space that may allow a volume increase in size of the battery pack 20 that may result from charging the battery pack 20.

5

FIG. 2 is a perspective view of the sheet plate 40 shown relative the upper case frame 11 of FIG. 1. FIG. 3 is a cross-sectional view of a portion of the electronic device 1 of FIG. 1 shown with the battery pack 20 mounted therein.

10

Referring to FIGS. 2 and 3, an opening 114 of a predetermined size is formed in the upper case frame 11. The opening 114 may be utilized as a space for mounting the battery pack 20 therein, and the sheet plate 40 may be disposed at a depth within the opening 114 to block the opening 114. The battery pack 20 may be mounted within the upper case frame 11, and may have a thickness that is substantially equal to the thickness of the upper case frame 11 minus the depth at which sheet plate 40 is disposed within the upper case frame 11.

15

The upper case frame 11 may be formed from a magnesium casting, and may, for example, be formed using die-casting but is not limited thereto and may be replaced by an injection material formed of a synthetic resin. The display module (not shown) of the electronic device 1 may be mounted on the upper side of the upper case frame 11.

20

Also, the sheet plate 40 may be formed of metal having a relatively fine thickness and strength. The materials for the sheet plate may be aluminum, SUS, etc. The sheet plate may be realized using a composite material such as GFRP and CFRP, which although not metal have similar properties to that of metal. Furthermore, the sheet plate 40 may be safely formed of inorganic materials such as glass or high polymer materials such as PC, etc.

25

As shown in FIG. 3, a seat surface 115 having a predetermined width may be formed in the opening 114 of the upper case frame 11 along the inner periphery of the opening 114 such that it is lower than the surface of the upper case frame 11, thereby forming a step threshold 116 in the boundary portion between the seat surface 115 and the upper case frame 11. Therefore, a predetermined portion of the edge of the sheet plate 40 contacts the seat surface 115 formed in the opening 114 of the upper case frame 11, and the sheet plate 40 is supported or guided by the step threshold 116 and seated upon and coupled to the seat

30

2014201219 28 Oct 2015

surface 115. At this point, the sheet plate 40 may be fixed to the upper case frame 11, for example, with an adhesive means such as bonding, a double-sided adhesive tape, etc. The step threshold 116 may be generated by a mechanical structure such as various ribs, etc. that are formed in the neighborhood of the inner edge of the opening 114 besides the seat surface.

5

Although sheet plate 40 is depicted in the appended figures as being rectangular, the sheet plate 40 may have other configurations. For example, the sheet plate may be formed in various shapes depending on the shape of the opening 114 of the upper case frame 11 to which the sheet plate is applied.

10

Referring to FIGS. 1 and 3, when the battery pack 20 is mounted in the electronic device 1, the concave recesses 221 and 222 formed in the first support body 22 of the battery pack 20 couple with corresponding protrusions (not shown) of the battery pack mount portion 102, and the plurality of seat protrusions 231, 232, 233 formed on the second support

15

body 23 are supported in a structure of being hooked at the recesses 111, 112, 113 of the battery pack mount portion 102 so that the sheet plate 40 is not influenced by the battery pack 20. In particular, even when an external force F (FIG. 3) is applied to the central portion of the battery pack 20 after the battery pack 20 is mounted in the battery pack mount portion 102, the sheet plate 40 is not struck by the battery pack 20 and is not deformed by the

20

external force F.

Since this structure allows the upper and lower ends, as well as the left and right sides of the battery pack 20, to be completely supported by the case frames 11 and 12 of the electronic device 1, the metal sheet plate 40 may be replaced by a lightweight plastic sheet or

25

a conductive tape, which may contribute to reduction of the entire thickness of the electronic device. Alternatively, the sheet plate 40 may be removed altogether, exposing the backside of the display module, and contributing to weight reduction and slimness of the electronic device 1.

30

FIG. 4 is a cutaway perspective view of FIG. 1 in which the battery pack 20 is mounted in the electronic device 1 according an embodiment of the present disclosure, FIG. 5 is a plan view partially illustrating a state where the battery pack 20 of FIG. 1 is mounted in the electronic device according to another embodiment of the present disclosure. FIG. 6 is a perspective view illustrating the battery pack 20 of FIG. 1 is mounted in the electronic

device according a still further embodiment of the present invention.

Referring to FIGS. 4 to 6, with the concave recesses 221 and 222 of the first support body 22 of the battery pack 20 coupled to corresponding protrusions (not shown) formed on the battery pack mount portion 102 of the main body 10 of the electronic device, the second support body 23 is lowered down in the direction of the battery pack mount portion 102. At this point, the seat protrusions 231, 232, 233 of the second support body 23 are hooked in such a way that the seat protrusions 231, 232, 233 are seated in the recesses 111, 112, 113 formed in the corresponding positions of the battery pack mount portion 102 so that both the upper and lower ends of the battery pack 20 may be supported.

As shown in FIG. 6, both the left and right of the battery pack 20 may be supported by the injection structure of the upper and lower case frames 11 and 12 of the main body 10.

As shown in FIG. 5, the seat protrusions 231, 232, 233 of the battery pack 20 and the recesses 111, 112, 113 formed in the upper case frame 11 of the battery pack mount portion 102 are designed such that an assembly interval (the space between each pair of opposing arrows of FIG. 5) is 0.1 mm or less so that left and right movement of the battery pack 20 is minimized after the battery pack 20 is mounted in the battery pack mount portion 102.

Also, as shown in FIG. 6, the space (the arrow portion of FIG. 6) between a support portion of the upper case frame 11 and lower case frames 12 for supporting the lateral sides of the battery pack 20 and the battery pack 20 may be about 0.05 mm or more, destruction of the case frame by a volume increase when the battery pack 20 is fully charged may be prevented in advance.

FIGS. 7 and 8 are perspective views illustrating a battery pack according an embodiment of the present disclosure.

Referring to FIG. 7, the battery pack 20 may include a battery cell 21, a first support body 22 and a second support body 23 installed at both ends of the battery cell. A pair of protrusions 223 and 224 which are different from the concave recesses 221 and 222 of the battery pack 20 of FIG. 1 may protrude from both ends of the first support body 22. A pair of concave recesses may be formed in the corresponding positions of the battery pack mount

portion 102 of the electronic device 1 in which the battery pack 20 is mounted. Also, a plurality of seat protrusions 231, 232, 233 may be formed having a predetermined shape on the second support body 23 so that the seat protrusions 231, 232, 233 may be seated in the recesses 111, 112, 113 in such a way that the seat protrusions 231, 232, 233 are hooked at the  
5 recesses 111, 112, 113 that are formed in the battery pack mount portion 102 of the main body 10.

With reference to FIG. 8, a battery pack 50, which is substantially similar to the battery pack 20 except in the ways explicitly stated herein, will now be described. The  
10 battery pack 50 includes a battery cell 51 and a seat rib 531 that extends in a widthwise direction along substantially an entire side of a support body 53 that is installed on one side of the battery cell 51.

Although not shown in the accompanying figures, in addition to the seat protrusions  
15 231, 232, 233 or the seat rib 531 protruding from the support body on one side of the battery pack 20 and 50 respectively, protrusions having a hooking structure may be formed in various shapes. Such protrusions, which facilitate securing or mounting the battery pack to battery pack mount portion 102 of the electronic device 1, may also prevent an external force from being transmitted to neighboring components (for example, the sheet plate, the display  
20 module, etc.).

The electronic device according to an embodiment of the present disclosure may prevent destruction of structures that neighbor the battery pack and of the battery pack itself by external force by allowing the battery pack to be easily detached, thereby preventing the  
25 force from being transmitted between the battery pack and its neighboring structures.

Although the invention has been shown and described with reference to certain exemplary embodiments thereof, it will be understood by those skilled in the art that various changes in form and details may be made therein without departing from the spirit and scope  
30 of the invention as defined by the appended claims and their equivalents. Therefore, the scope of the present invention should not be limited to the above-described embodiments but should be determined by not only the appended claims but also the equivalents thereof.

In the claims which follow and in the preceding description of the invention, except

where the context requires otherwise due to express language or necessary implication, the word “comprise” or variations such as “comprises” or “comprising” is used in an inclusive sense, i.e. to specify the presence of the stated features but not to preclude the presence or addition of further features in various embodiments of the invention.

5

It is to be understood that, if any prior art publication is referred to herein, such reference does not constitute an admission that the publication forms a part of the common general knowledge in the art, in Australia or any other country.

10

2014201219 28 Oct 2015

**CLAIMS:**

1. An electronic device comprising:  
 a battery pack;  
 5 a case frame having an opening forming a battery pack mount portion in which the battery pack is mounted; and  
 a sheet plate blocking the opening at a backside of the battery pack mount portion;  
 wherein the battery pack comprises:  
 10 a battery cell; and  
 first and second support bodies supporting the battery cell on opposing ends of the battery cell;  
 wherein the first support body includes either a recess or protrusion; and  
 wherein one or more seat protrusions protrude from the second support body  
 15 to an outer direction;  
 wherein the battery pack mount portion comprises:  
 one or more seat recesses in which the one or more seat protrusions are seated; and  
 a protrusion or recess corresponding to the first support body recess  
 20 or protrusion; and  
 wherein when the battery pack is mounted the one or more seat protrusions are supported by the seat recesses, and the first support body recess or protrusion is coupled to the corresponding protrusion or recess.
- 25 2. The electronic device of claim 1, wherein the sheet plate is disposed at a depth within the opening to block the opening, and wherein when the battery pack is mounted the battery pack overlies the sheet plate.
3. The electronic device of claim 1, wherein a plurality of the one or more seat  
 30 protrusions protrude at a predetermined interval to the outer direction from the second support body.
4. The electronic device of claim 1, wherein the one or more seat protrusions are formed to protrude in a rib shape from the second support body.

5. The electronic device of claim 1, wherein both a left and a right side of the battery pack mount portion is formed in a bent shape entering in a direction of the battery pack mount portion toward a lower side in order to support both a left and a  
5 right of the battery pack.

6. The electronic device of claim 1, wherein the electronic device has a backside, and wherein the battery pack mount portion has a mount space formed to be lower than the backside of the electronic device.

10

7. The electronic device of claim 6, wherein the one or more seat protrusions are configured such that they do not protrude beyond the upper side of the battery pack or the backside of the electronic device when the one or more seat protrusions are seated in the one or more seat recesses.

15

8. The electronic device of claim 1, wherein the electronic device includes a backside, and further comprises a detachable cover, the detachable cover being coupled to the battery pack mount portion and forming at least a portion of the backside of the electronic device.

20

9. The electronic device of claim 1, wherein the electronic device is a mobile terminal.

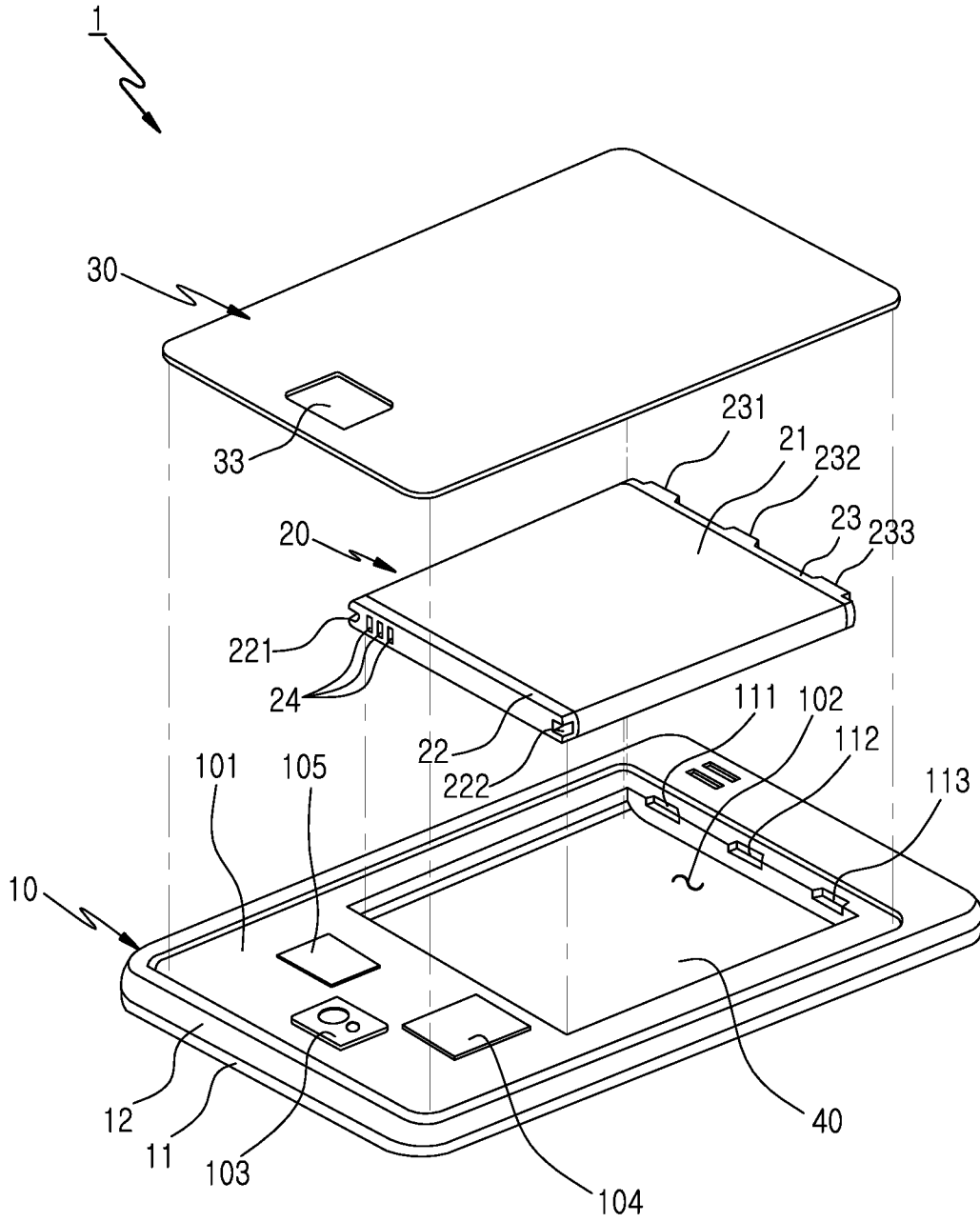

FIG.1

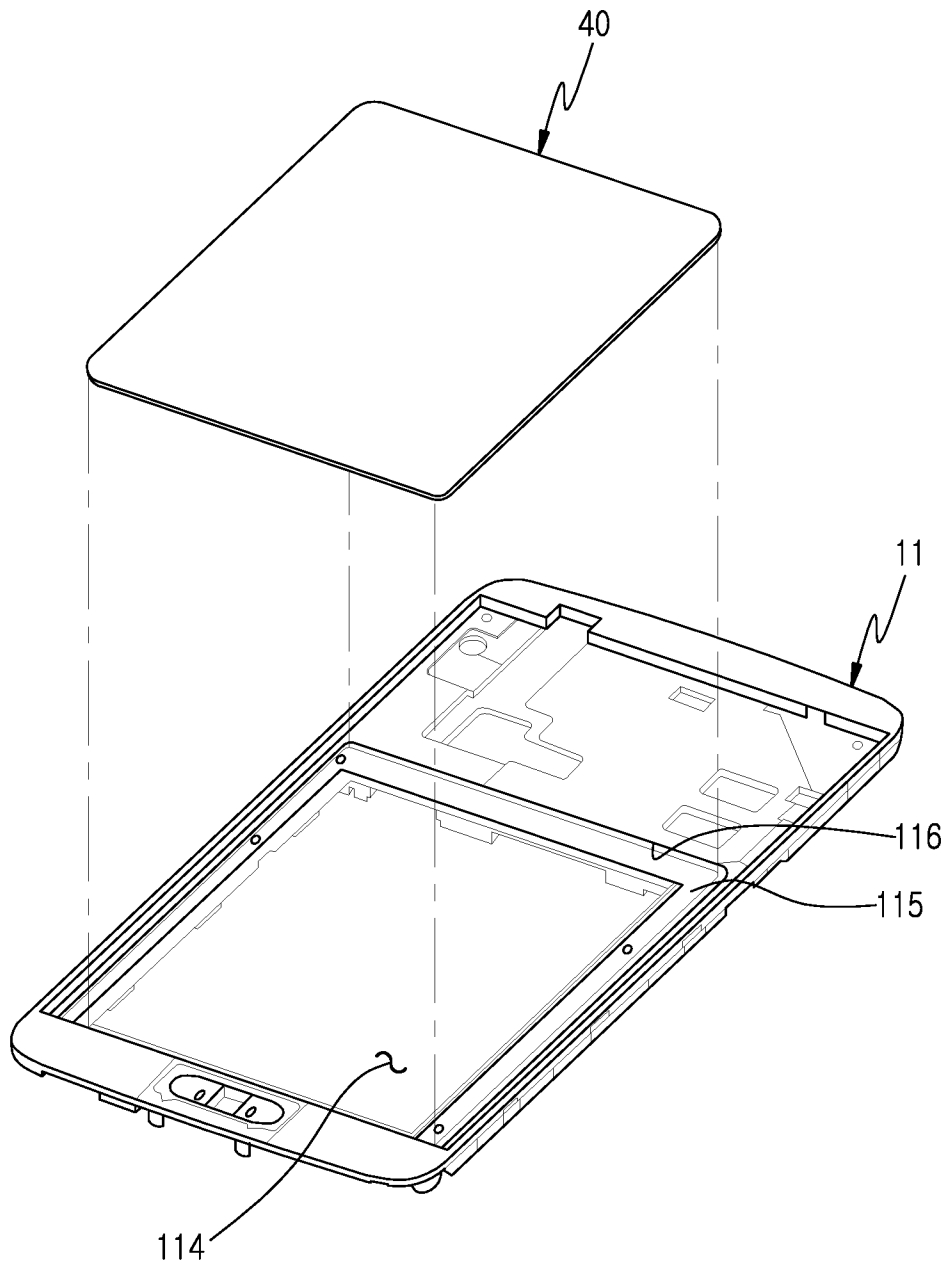

FIG.2

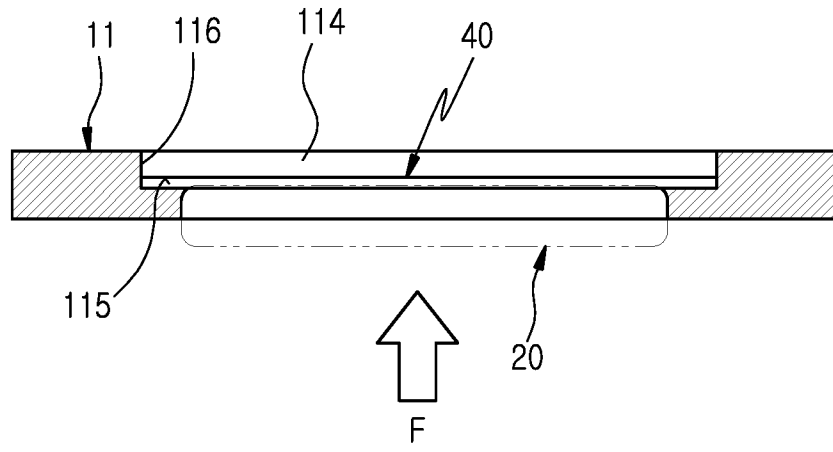

FIG.3

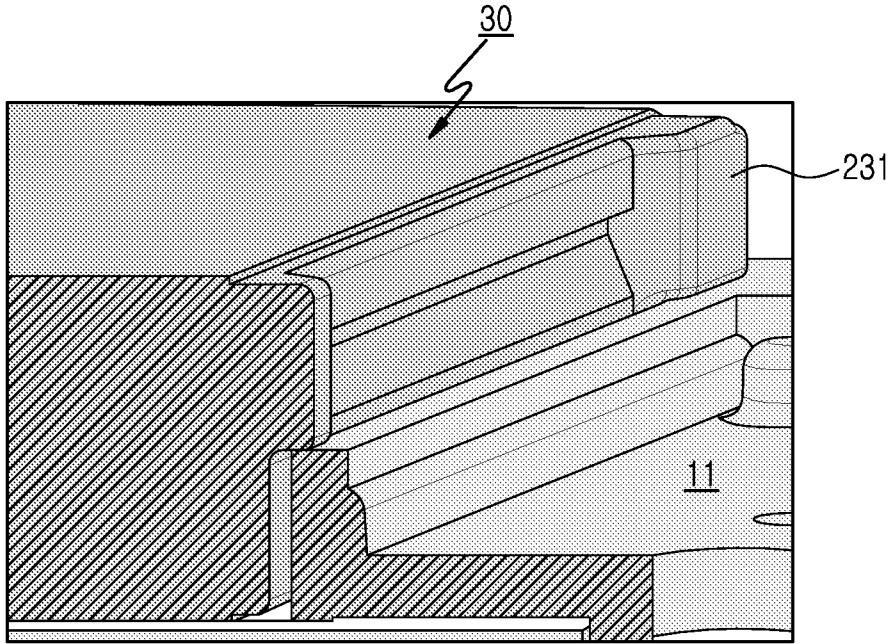

FIG.4

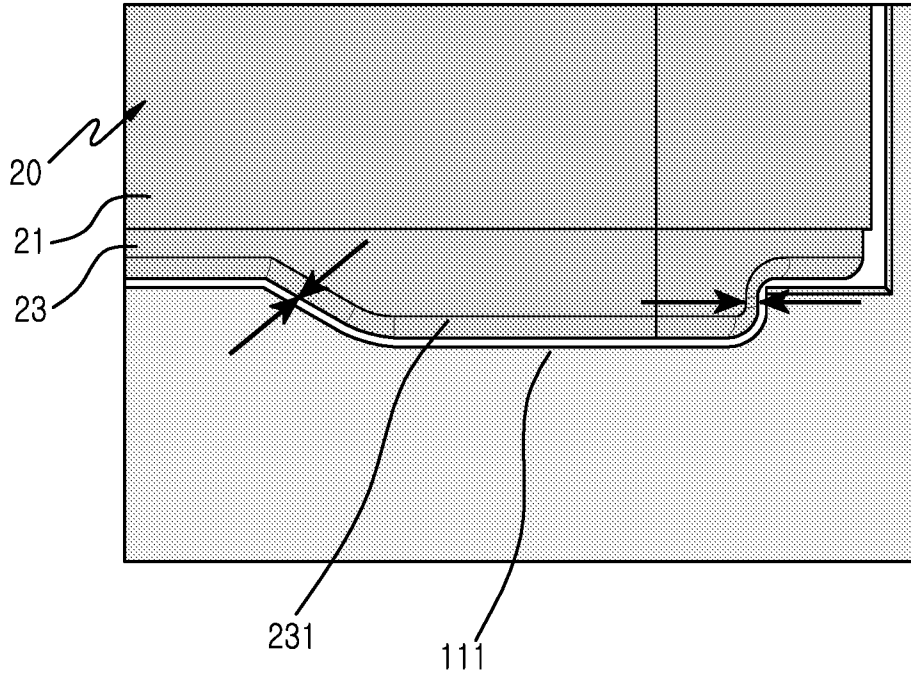

FIG.5

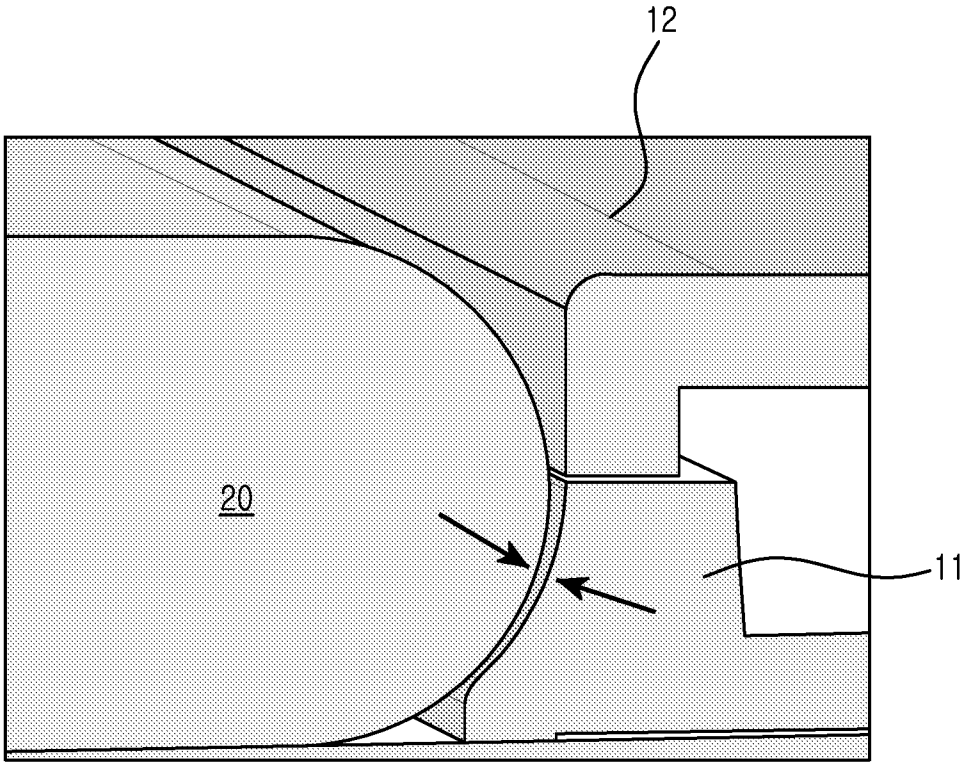

FIG.6

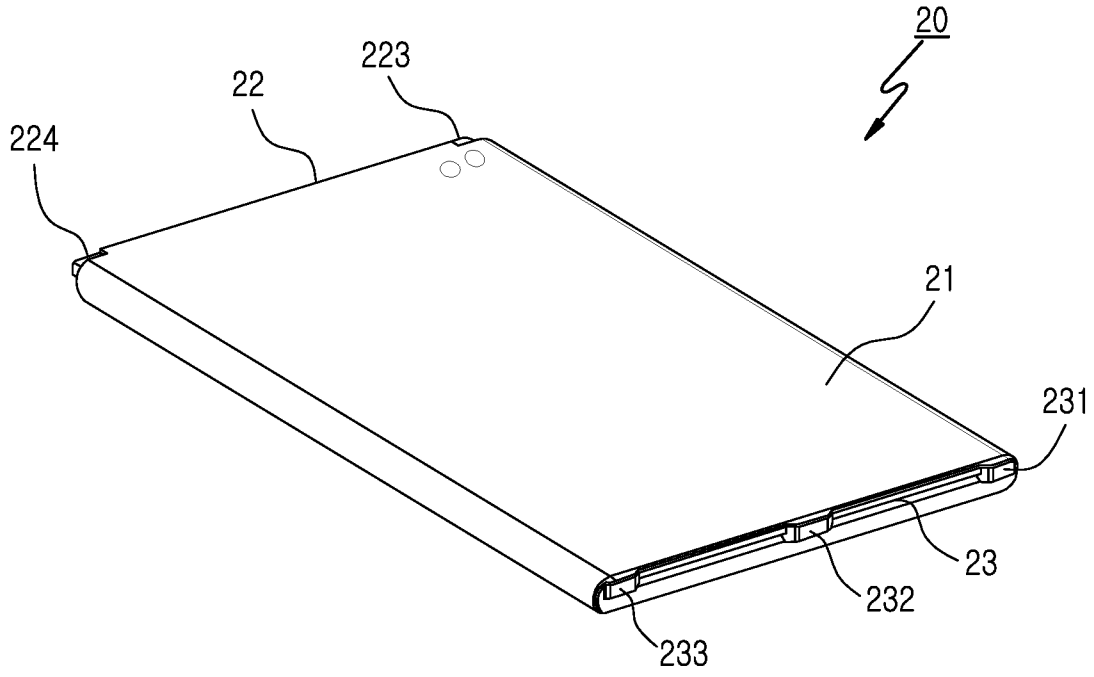

FIG. 7

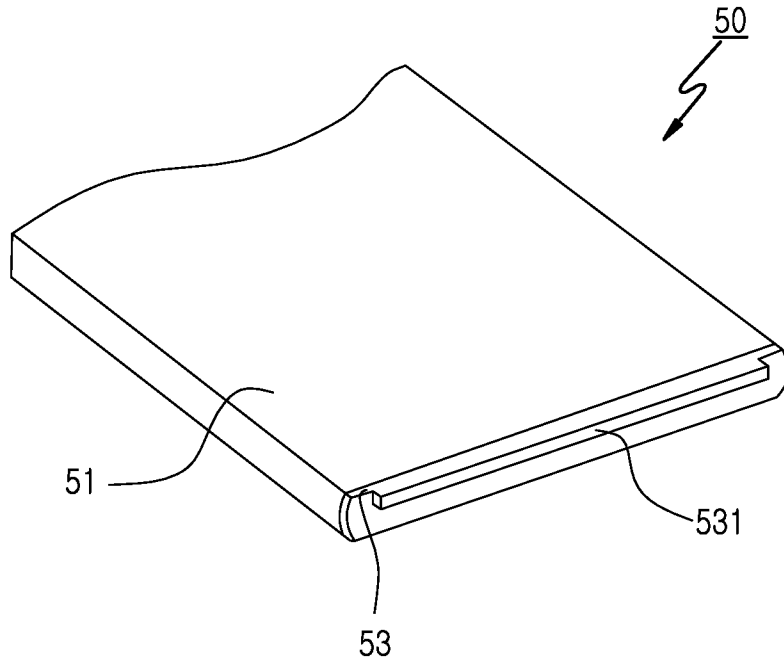

FIG. 8