

(19)



(11)

EP 3 085 437 B1

(12)

EUROPEAN PATENT SPECIFICATION

(45) Date of publication and mention of the grant of the patent:
19.09.2018 Bulletin 2018/38

(51) Int Cl.:
B01F 13/10 ^(2006.01) **B01F 15/00** ^(2006.01)
B01F 15/02 ^(2006.01) **B01F 15/04** ^(2006.01)

(21) Application number: **16166016.2**

(22) Date of filing: **19.04.2016**

(54) **SYSTEM AND METHOD FOR DELIVERY OF FLUIDS, IN PARTICULAR COLOURED FLUIDS**
SYSTEM UND VERFAHREN ZUR ABGABE VON FLUIDEN, INSBESONDERE FARBIGEN FLUIDEN
SYSTÈME ET PROCÉDÉ DE DISTRIBUTION DE FLUIDES, EN PARTICULIER DE FLUIDES COLORÉS

(84) Designated Contracting States:
AL AT BE BG CH CY CZ DE DK EE ES FI FR GB GR HR HU IE IS IT LI LT LU LV MC MK MT NL NO PL PT RO RS SE SI SK SM TR

(30) Priority: **20.04.2015 IT UB20150282**

(43) Date of publication of application:
26.10.2016 Bulletin 2016/43

(73) Proprietor: **INKMAKER S.r.l.**
10040 San Gillio (TO) (IT)

(72) Inventors:
• **MUSSO, CARLO**
I-10040 San Gillio (TO) (IT)

• **COMELLI, DAVIDE**
I-10024 Moncalieri (TO) (IT)

(74) Representative: **Reposio, Giancarlo et al**
c/o Metroconsult S.r.l.
Via Sestriere 100
10060 None (TO) (IT)

(56) References cited:
EP-A2- 2 452 996 **WO-A2-2012/123977**
US-A- 4 827 993 **US-A- 5 215 131**
US-A1- 2014 017 392

EP 3 085 437 B1

Note: Within nine months of the publication of the mention of the grant of the European patent in the European Patent Bulletin, any person may give notice to the European Patent Office of opposition to that patent, in accordance with the Implementing Regulations. Notice of opposition shall not be deemed to have been filed until the opposition fee has been paid. (Art. 99(1) European Patent Convention).

Description

[0001] The present invention relates to a system and a method for delivery of fluids, in particular coloured fluids, solvents, water-based paints, inks, etc. For example, document US4827993A relates to an automatic system for carrying a reservoir and metering liquid from the reservoir. Said document discloses a system according to the preamble of claim 1. Current fluid dosage systems make use of integrated dosage machines for correctly dosing the fluids in order to implement a final formula. A final formula is meant to be a compound obtained by means of a single fluid or a mixture of at least two fluids. Current integrated dosage machines comprise a fluid accumulation assembly, a dosage head, and a scale for dosing the components, i.e. the single fluids, in a sequential manner and for moving the containers in order to remove the final product.

[0002] However, such dosage machines must fill up one container at a time for each formula while adding all components sequentially, and this translates into slow production and low profits for the producers.

[0003] Moreover, current valve washing systems use water or solvents that, at the end of the washing process, create dirt and/or pollution. In particular, when solvent is used, its vapours dispersed in the working environment may cause explosions, thus jeopardizing the safety of the operators and of the entire working environment.

[0004] It is therefore one object of the present invention to provide a system and a method for delivery of fluids, in particular coloured fluids, which will improve automation and production times.

[0005] It is another object of the present invention to provide a system and a method for delivery of fluids, in particular coloured fluids, which will increase the finished product production volumes per time unit.

[0006] It is a further object of the present invention to provide a system and a method for delivery of fluids, in particular coloured fluids, which will respect the working environment while making it safer.

[0007] These and other objects of the invention are achieved by a system and a method for delivery of fluids as claimed in the appended claims, which are an integral part of the present description.

[0008] In brief, a system for delivery of fluids, in particular coloured fluids, is described herein, which is adapted to implement a dosage process wherein containers are filled up in order to obtain a finished product according to a given formula, said formula being representative of the dosage and/or composition of one or more fluids. The system according to the invention comprises the features of claim 1.

[0009] Further features of the invention are set out in the appended claims, which are intended to be an integral part of the present description.

[0010] The above objects will become more apparent from the following detailed description of a system and a method for delivery of fluids, in particular coloured flu-

ids, with particular reference to the annexed drawings, wherein:

- Figure 1 is a first schematic top view of a system according to the invention;
- Figure 2 is a second schematic top view of the system according to the invention;
- Figure 3 is a schematic representation of the system according to the invention;
- Figures 4A, 4B, 4C and 4D show steps of one example of operation of the system according to the invention;
- Figure 4E shows a further example of a system according to the present invention;
- Figure 5A shows a first configuration of a fluid magazine of the system according to the present invention;
- Figures 5B and 5C show a second configuration of a fluid magazine of the system according to the present invention.

[0011] With reference to Figures 1 and 2, there is schematically shown a system 1 for delivery of fluids according to the present invention. In particular, Fig. 1 and Fig. 2 show a schematic top view of the system 1.

[0012] The system 1 comprises a dosage line 3 and at least one magazine 5,7. Preferably, a first magazine 5 is arranged along a first side of the dosage line 3, and a second magazine 7 is arranged along a second side of the dosage line 3.

[0013] The dosage line 3 comprises motion means 31, e.g. an automatic conveyor, adapted to move, in the sense and direction of an arrow A, containers $B_1, B_2, B_3, \dots, B_n$ on support means of the dosage line 3, e.g. a roller track. The dosage line 3 comprises P stations $S_1, S_2, S_3, \dots, S_p$, wherein at each p-th station S an n-th container B and an i-th delivery actuator $E (E_1, E_2, E_3, \dots, E_i)$ can be placed, the latter being arranged in proximity to an opening of an n-th container B. Said i-th delivery actuator E allows delivering the fluid into the n-th container B.

[0014] The first magazine 5 and the second magazine 7 comprise delivery valves $V_1, V_2, V_3, \dots, V_m$, wherein a storage point $D_1, D_2, D_3, \dots, D_m$ corresponds to each one of them. Each delivery valve $V_1, V_2, V_3, \dots, V_m$ can be connected, through fluid transportation means, to a tank containing a certain fluid, in particular a coloured fluid. More in detail, the fluid transportation means comprise a delivery pump connected to the tank, and a tube with one end connected to the delivery pump; the other end of the tube is connected to the delivery valve V_m . It is clear that the fluid transportation means may comprise technical elements that are alternative to the above-mentioned ones.

[0015] Preferably, the dosage line 3 comprises washing modules $L_1, L_2, L_3, \dots, L_j$, each one of which is arranged in proximity to the dosage point. Furthermore, at every station S there is a scale that measures and de-

termines the weight of the container B; this is useful for determining the quantity of fluid delivered into the containers B when the latter are being filled with a fluid.

[0016] In general, it can be stated that, when the dosage process is running, at each station S there is one container B, one delivery actuator E, one scale, and, preferably, one washing module L.

[0017] The function of the washing module L is to wash, and possibly also dry, the delivery valves V once the dosage process has been completed. The term "dosage process" refers herein to an operating process during which the containers B are filled in order to obtain a finished product for each formula.

[0018] The system 1 further comprises a robot 9, in particular a robotic arm, which is free to move forwards and backwards in a longitudinal direction (reference arrow RO) and in a transversal direction (reference arrow RV) of the dosage line 3. The robot 9 is therefore adapted to pick up a delivery valve $V_1, V_2, V_3, \dots, V_m$ from a storage point $D_1, D_2, D_3, \dots, D_m$ and place it at a dosage point of the dosage line 3, i.e. on a delivery actuator $E_1, E_2, E_3, \dots, E_i$ in proximity to an opening of a corresponding container $B_1, B_2, B_3, \dots, B_n$.

[0019] With reference to Fig. 3, the system 1 comprises a control unit 11 configured for controlling and monitoring the operation and effectiveness of the whole system 1. More in detail, the control unit 11 comprises at least one processor and memory means (not shown in the drawings), which can execute machine instructions for checking and controlling the system 1. The control unit 11 is connected to the first magazine 5, the dosage line 3, the second magazine 7, and the robot 9; therefore, the control unit 11 can exchange data with said elements 3, 5, 7 and 9.

[0020] For example, the control unit 11 controls PLC ("Programmable Logic Controller") modules included in the dosage line 3, in the first magazine 5, and in the second magazine 7.

[0021] With reference to Figures 2, 4A, 4B, 4C and 4D, the following will illustrate in detail the operation of the system 1.

[0022] Let us consider that the whole dosage process will lead to obtaining a finished product, which will be the outcome of a formula.

[0023] Let us also assume that the formula of the example requires the use of four coloured fluids.

[0024] With reference to Fig. 4A, at step 1 a first container B_1 is positioned on the support means of the dosage line 3 while passing through and entry area 13 of the dosage line 3. The first container B_1 is *de facto* positioned at a first station S_1 , where there are a first delivery actuator E_1 and a first washing module L_1 , as well as a first scale. A robot 9 picks up, at a storage point D_1 , a first delivery valve V_1 associated with a first coloured fluid 17, and moves it towards the first delivery actuator E_1 , which will allow it to open, so that the first coloured fluid 17 will be delivered into the first container B_1 . While the first coloured fluid 17 is being delivered, the first scale con-

tinuously checks the weight of the first container B_1 , until it reaches a limit value dictated by the formula, e.g. 10% of the whole composition. When the first scale detects such limit value, the first delivery actuator E_1 will command the first delivery valve V_1 to close. At the end of step 1, the first container B_1 will thus only contain the first coloured fluid 17.

[0025] With reference to Fig. 4B, at step 2 the motion means allow the first container B_1 to translate or advance towards the second station S_2 (in the direction of the arrow A) and, preferably at the same time, a second container B_2 is positioned, from the entry area 13, onto the first station S_1 . It is worth specifying that it is the control unit 11 that controls the motion means for moving the containers B_n from a first station to a second station when the fluid reaches the limit value dictated by said formula.

[0026] As a consequence, the first delivery actuator E_1 commands the first delivery valve V_1 to open, thereby allowing the first coloured fluid 17 to be delivered into the second container B_2 . At the same time, preferably, the robot 9 picks up, from a storage point D_2 , a second delivery valve V_2 associated with a second coloured fluid 19, and moves it towards the second delivery actuator E_2 , which will allow it to open, so that the second coloured fluid 19 will be delivered into the first container B_1 . At the second station S_2 , a second scale checks the weight of the first container B_1 until it reaches a limit value dictated by the formula, e.g. 30% of the whole composition (in other words, the second coloured fluid 19 is delivered in a quantity equal to 20% of the entire composition). When the second scale detects such limit value, the second delivery actuator E_2 will command the second delivery valve V_2 to close; likewise, the first delivery valve V_1 will be closed at the first station S_1 for the first coloured fluid 17, which will have been delivered up to a limit value of 10% of the whole composition.

[0027] At the end of step 2 of the method, the first container B_1 will contain 10% of the first coloured fluid 17 and 20% of the second coloured fluid, whereas the second container B_2 will only contain 10% of the first coloured fluid 17.

[0028] With reference to Fig. 4C, at step 3 the motion means allow the first container B_1 to translate or advance towards the third station S_3 and the second container B_2 to translate or advance towards the second station S_3 . At the same time, preferably, a third container B_3 is positioned onto the first station S_1 .

[0029] As a consequence, the first delivery actuator E_1 commands the first delivery valve V_1 to open, thereby allowing the first coloured fluid 17 to be delivered into the third container B_3 , in compliance with the limit value dictated by the formula. The second delivery actuator E_2 commands the second delivery valve V_2 to open, thereby allowing the second coloured fluid 19 to be delivered into the second container B_2 , in compliance with the limit value dictated by the formula. At the same time, preferably, the robot 9 picks up, from a storage point D_3 , a third delivery valve V_3 associated with a third coloured fluid

21, and moves it towards the third delivery actuator E_3 , which will allow it to open, so that the third coloured fluid 21 will be delivered into the first container B_1 . At the third station S_3 , a third scale checks the weight of the first container B_1 until it reaches a limit value dictated by the formula, e.g. 60% of the whole composition (in other words, the third coloured fluid 21 will be delivered in a quantity equal to 30% of the entire composition).

[0030] When the third scale detects the limit value, the third delivery actuator E_3 will command the third delivery valve V_3 to close; also, the first delivery valve V_1 will be closed at the first station S_1 for the first coloured fluid 17 when a limit value of 10% of the whole composition is reached, and the second delivery valve V_2 will be closed at the second station S_2 for the second coloured fluid 19 when a limit value of 20% of the whole composition is reached.

[0031] At the end of step 3, the first container B_1 will contain 10% of the first coloured fluid 17, 20% of the second coloured fluid 19, and 30% of the third coloured fluid 21, whereas the second container B_2 will contain 10% of the first coloured fluid 17 and 20% of the second coloured fluid 19, and, finally, the third container B_3 will only contain 10% of the first coloured fluid 17.

[0032] With reference to Fig. 4D, at step 4 the motion means allow the first container B_1 to translate or advance towards a fourth station S_4 , the second container B_2 to translate or advance towards the third station S_3 , and the third container B_3 to translate or advance towards the second station S_2 . At the same time, preferably, a fourth container B_4 is positioned onto the first station S_1 .

[0033] As a consequence, the first delivery actuator E_1 commands the first delivery valve V_1 to open, thereby allowing the first coloured fluid 17 to be delivered into the fourth container B_4 , in compliance with the limit value dictated by the formula. The second delivery actuator E_2 commands the second delivery valve V_2 to open, thereby allowing the second coloured fluid 19 to be delivered into the third container B_3 , in compliance with the limit value dictated by the formula. The third delivery actuator E_3 commands the third delivery valve V_3 to open, thereby allowing the third coloured fluid 21 to be delivered into the second container B_2 , in compliance with the limit value dictated by the formula.

[0034] At the same time, preferably, the robot 9 picks up, from a storage point D_4 , a fourth delivery valve V_4 associated with a fourth coloured fluid 23, moves it towards the fourth delivery actuator E_4 , which will allow it to open, so that the fourth coloured fluid 23 will be delivered into the first container B_1 . At the fourth station S_4 , a fourth scale checks the weight of the first container B_1 until it reaches a limit value dictated by the formula, e.g. 100% of the whole composition (in other words, the fourth coloured fluid 21 will be delivered in a quantity equal to 40% of the entire composition).

[0035] When the fourth scale detects the limit value, the fourth delivery actuator E_4 will command the fourth delivery valve V_4 to close; also, the first delivery valve V_1

will be closed at the first station S_1 for the first coloured fluid 17 when a limit value of 10% of the whole composition is reached, the second delivery valve V_2 will be closed at the second station S_2 for the second coloured fluid 19 when a limit value of 20% of the whole composition is reached, and the third delivery valve V_3 will be closed at the third station S_3 for the third coloured fluid 21 when a limit value of 30% of the whole composition is reached.

[0036] At the end of step 4, the first container B_1 will contain 10% of the first coloured fluid 17, 20% of the second coloured fluid 19, 30% of the third coloured fluid 21, and 40% of the fourth coloured fluid 23. The second container B_2 will contain 10% of the first coloured fluid 17, 20% of the second coloured fluid 19, and 30% of the third coloured fluid 21. The third container B_3 will contain 10% of the first coloured fluid 17 and 20% of the second coloured fluid 19, whereas the fourth container B_4 will only contain 10% of the first coloured fluid 17.

[0037] Therefore, the first container B_1 will contain the finished product and can be picked up by a lift truck and removed through an exit 15 of the dosage line 3.

[0038] The steps of the dosage process just described represent, *de facto*, a transient during which the dosage line 3 is loaded with containers B and these are filled up with coloured fluids in order to obtain the finished product. Therefore, the dosage process can be continued by feeding containers B into the dosage line 3, as long as a user wants to keep the same composition formula. When the user decides to change the formula of the composition of the finished product, the dosage process will be considered to end. Note that the delivery valves V_m , once they have been placed at the dosage point E_i , will remain stationary throughout the duration of the dosage process. In other words, it is the control unit 11 that commands said delivery valves V_m , once they have been placed at the dosage point E_i , to remain stationary at the dosage point throughout the duration of the dosage process.

[0039] When a maximum number of containers B to be filled up is reached, the dosage line 3 will be emptied by removing the n-th container B.

[0040] When the dosage line 3 is clear, and therefore the production of finished products having a given formula is complete, the robot 9 will pick up each delivery valve V_m and position it at the corresponding washing module L_j . The washing modules L_j will wash, and possibly dry, the delivery valves V_m in such a way that, when the latter are moved to the corresponding storage points D_m , no dripping will occur in the environment. In particular, the washing modules L_j are hermetically sealed, so as to avoid any leakage of product (inks, solvents, dirty water, etc.) into the working environment.

[0041] As an alternative, the delivery valves V_m may be washed, and possibly dried, when the fluid for the current formula is no longer used during the dosage process, in particular when the dosage line 3 is going through the phase wherein the containers B are removed (final step of the dosage process).

[0042] The dosage head is that part of the support which comprises the washing modules L_j and the delivery actuators E_i . This part of the support can move horizontally and vertically relative to the plane of the dosage line 3. The horizontal motion of the dosage head occurs circularly with respect to a fixed point, since the dosage head is hinged at one point, and allows the space above the containers B_n to be easily cleared whenever necessary.

[0043] It is worth pointing out that all of the above-mentioned steps are checked and controlled by the control unit 11. In fact, the information about the formula to be applied is entered into the memory means of the control unit 11. More in detail, such formula information comprises the following data:

- order of delivery of the fluids, and hence which fluid must be associated to a station S_p ;
- quantity, in terms of weight and percentage of the whole composition, to be delivered into the containers B_n for each fluid;
- optionally, number of containers B_n to be filled up with the composition of a formula.

[0044] It is also important to stress that the association between a fluid and a station S_p allows saving time throughout the dosage process; in fact, said association will not change until the formula of the composition is changed. As a consequence, the robot 9 will advantageously have to carry out only a few operations in the transient phase of the dosage process for picking up the delivery valves V_m , and in the final phase of the dosage process for washing them and possibly storing them in the magazines 5, 7 (storage points D_m).

[0045] Preferably, the delivery valves V_m are stored in reverse order compared to the order in which the delivery valves V_m were picked up from their storage point D_m (during the initial transient phase of a dosage process). This will avoid any interference with the tubes connected to the delivery valves V_m .

[0046] In the example illustrated so far of the system 1 according to a first embodiment of the invention, there is a dosage line 3 with a plurality of stations S . However, in a second embodiment of the system 1 according to the invention, the dosage line 3 comprises just a single station S , where the robot 9 moves the delivery valves V_m in order to deliver the fluids. In this case, no movements of the containers B will occur on the dosage line 3, but as for the rest the operation of the system will remain unchanged.

[0047] Furthermore, in both the first and second embodiments of the system 1, it is possible to equip at least one station S with a plurality of delivery actuators E_i . In other words, each station S may have multiple delivery actuators E_i capable of receiving delivery valves V_m , so as to speed up the production process carried out by the system 1.

[0048] With reference to Fig. 4E, there is shown an

example of a dosage line 3 wherein two delivery actuators E_i are present at each station S .

[0049] With reference to Figs. 5A, 5B and 5C, two possible configurations of the first magazine 5 and second magazine 7 will now be described.

[0050] More in detail, Fig. 5A shows a side view of the system 1 as a whole.

[0051] As can be seen in Fig. 5A, according to a first configuration the first magazine 5 and the second magazine 7 comprise, respectively, a first cable drag chain 51 and a second cable drag chain 71. The first cable drag chain 51 and the second cable drag chain 71 comprise coupling means 52,72 adapted to connect the fluid transportation means 25, in particular a tube 25, to a tank located in the first magazine 5 or in the second magazine 7.

[0052] In particular, said coupling means 52,72 are arranged vertically with respect to the support plane of the first magazine 5 and of the second magazine 7, and one above the other. A tube 25 carrying a specific coloured fluid is connected to each coupling means 52,72.

[0053] A delivery valve V_m , designated by reference numeral 27, is connected to one end of the tube 25. Preferably, the tube 25 is flexible, and is therefore advantageously laid on a support line 29 that extends throughout the length of the dosage line 3. The support line 29 avoids any interference between the tubes 25 when they are arranged over the delivery actuators E_i . Preferably, each valve 27 may be provided with a fluid recirculation tube.

[0054] As previously illustrated, the robot 9 can move in two directions, i.e. longitudinally (arrow designated RO) and transversally (arrow designated RV) relative to the dosage line 3. More in detail, the robot 9 is an electromechanical arm equipped with a clamp 91 at one end, possibly an extensible one, which can work in the area comprised between the first magazine 5 and the second magazine 7, and at least throughout the length of the dosage line 3. Preferably, the robot 9 is anchored to a portal 8 provided with guiding means adapted to allow the same robot 9 to move in the two longitudinal and transversal directions.

[0055] In a variant of the invention, the robot 9 can also be used for moving the containers B_n along the dosage line 3 during the dosage process.

[0056] According to a second configuration, with particular reference to Figures 5B and 5C, the first magazine 5 and the second magazine 7 comprise a first monorail assembly 53 and a second monorail assembly 73, to which the fluid transportation means 25 can be connected. The first magazine 5 is identical to the second magazine 7, and therefore only the first magazine 5 will be described in detail. The first monorail assembly 53 comprises at least one monorail 31 where carriages 33 are arranged, which can translate in the direction of the monorail 31, said carriages 33 being each equipped with a support 34 for bearing the tube 25 that transports the coloured fluid from a drum 35 to the delivery valve V_m , designated by reference numeral 27, by means of a de-

livery pump 36. Preferably, the at least one monorail 31 is arranged parallel to the dosage line 3; the robot 9 can thus operate along all monorails 31, so as to be able to pick up the delivery valves V_m from their storage points D_m . In particular, the delivery valves V_m are positioned at the corresponding storage points D_m on a rack 37 which is also useful as a support for the tube 25.

[0057] Advantageously, said second configuration of the fluid magazine 5,7 allows the tube 25 to be easily extended because, when the robot 9 picks up and moves the delivery valve V_m on the delivery actuator E_i , the tube 25 will extend due to the carriages 33 running along the monorail 31.

[0058] The following will describe a method of delivery of fluids according to the present invention, adapted to implement a dosage process wherein containers B_n are filled up in order to obtain a finished product according to a given formula, said formula being representative of the dosage and/or composition of one or more fluids. Said method comprises the features of claim 14.

[0059] The method further envisages to:

- move a first container B_n from a first station to a second station, if the dosage line 3 comprises a plurality of stations S_p ;
- place a second container B_n at the entry of the dosage line 3;
- repeat the previous steps until a formula of a composition of said fluids is completed, i.e. until one wants to end the dosage process;
- associate a fluid with one station of the plurality of stations S_p comprised in the dosage line 3, said association remaining valid throughout the duration of the dosage process.

[0060] The dosage process may also end on the basis of the number of containers B_n to be filled up with the composition of a formula, i.e. when the preset number of containers B_n to be filled up is reached. For example, a user may store said preset number of containers B_n to be filled up into the memory means of the control unit 11, which will then verify, by means of a count sensor positioned along the dosage line 3, the number of containers B_n containing the finished product. When the preset number of containers B_n is reached, the dosage process will end.

[0061] The method optionally envisages to:

- wash, and possibly dry, at least one delivery valve V_m at the end of the dosage process.

[0062] The washing and drying operations may alternatively be carried out when the fluid for the current formula no longer needs to be used during the dosage process, in particular when the dosage line 3 is executing the step of removing the containers B (final step of the dosage process).

[0063] Preferably, at the end of the dosage process

(before or after the washing and/or drying operations), the robot 9 will bring the delivery valves V_m back to their respective storage points D_m . Preferably, the method according to the invention envisages to bring the delivery valves V_m back to their respective storage points D_m in reverse order compared to the order in which the same delivery valves V_m were picked up from their storage point D_m .

[0064] As an alternative, the method envisages to bring the delivery valves V_m back to their respective storage points D_m in an arbitrary order.

[0065] The present invention also relates to a computer program product which can be loaded into memory means of said control unit 11 and which is adapted to implement the method according to the invention.

[0066] The features of the present invention, as well as the advantages thereof, are apparent from the above description.

[0067] A first advantage of the system and method for delivery of fluids according to the present invention is that they ensure better system automation and shorter production times.

[0068] A second advantage of the invention is that it ensures higher production volumes of finished product.

[0069] A further advantage of the invention is that the working environment will be cleaner and safer for the operators.

[0070] The system and method for delivery of fluids described herein by way of example may be subject to many possible variations; it is also clear that in the practical implementation of the invention the illustrated details may have different shapes or be replaced with other technically equivalent elements.

[0071] For example, the system for delivery of fluids may comprise a plurality of dosage lines, in particular arranged side by side, so that production can be maximized.

[0072] In another variant, the robot may pick up the delivery valves V_m in a different order than that in which the fluids are loaded for the composition of the final formula.

Claims

1. System (1) for delivery of fluids, in particular coloured fluids, adapted to implement a dosage process wherein containers (B_n) are filled up in order to obtain a finished product according to a given formula, said formula being representative of the dosage and/or composition of one or more fluids, said system (1) comprising:

- at least one dosage line (3) comprising at least one station (S_p);
- at least one magazine (5,7) comprising delivery valves (V_m), wherein a storage point (D_m) corresponds to each one of them, and wherein they

are connected to a tank containing a fluid by means of fluid transportation means (25,36);
 - a robot (9) adapted to pick up at least one of said delivery valves (V_m) from said storage point (D_m) and place it at a dosage point of said at least one station (S_p);
 - a control unit (11), adapted to control and monitor said at least one dosage line (3), said at least one magazine (5,7), and said robot (9),

said system (1) being **characterized in that**

said at least one magazine (5,7) comprises a cable drag chain (51,71) comprising coupling means (52,72) adapted to connect said fluid transportation means (25) to said tank of said at least one magazine (5,7).

2. System (1) according to claim 1, wherein said at least one dosage line (3) comprises a plurality of stations (S_p) and is configured for moving said containers (B_n) from a first station to a second station of said plurality of stations (S_p), and said control unit (11) is configured for associating said fluid with a station of said plurality of stations (S_p) throughout the duration of said dosage process.
3. System (1) according to claim 2, wherein said at least one station (S_p) comprises a scale adapted to determine the weight of a container (B_n) during the delivery of said fluid, and wherein said control unit (11) commands the movement of said containers (B_n) from said first station to said second station when said fluid has reached a limit value dictated by said formula.
4. System (1) according to one or more of the preceding claims, wherein said control unit (11) commands said delivery valves (V_m), once they have been placed at said dosage point, to remain stationary at said dosage point throughout the duration of said dosage process.
5. System (1) according to one or more of the preceding claims, wherein said at least one station (S_p) comprises a washing module (L_j) arranged in proximity to said dosage point and adapted to wash said delivery valves (V_m) at the end of said dosage process.
6. System (1) according to the preceding claim, wherein said washing module (L_j) is adapted to dry said delivery valves (V_m) at the end of said dosage process.
7. System (1) according to one or more of the preceding claims, wherein said robot (9) moves said delivery valves (V_m) back to their respective storage points (D_m) after the end of said dosage process.

8. System (1) according to one or more of the preceding claims, wherein said at least one magazine (5,7) is arranged on at least one side of said at least one dosage line (3).
9. System (1) according to one or more of the preceding claims, wherein said robot (9) is free to move forwards and backwards in a longitudinal direction and in a transversal direction of said at least one dosage line (3).
10. System (1) according to one or more of the preceding claims, wherein said at least one dosage line (3) comprises motion means (31), in particular an automatic conveyor, adapted to move said containers (B_n) on support means of said at least one dosage line (3).
11. System (1) according to one or more of claims 1 to 9, wherein said robot (9) is adapted to move said containers (B_n) on support means of said at least one dosage line (3).
12. System (1) according to claim 1, wherein said coupling means (52,72) are arranged vertically with respect to a support plane of said at least one magazine (5,7), and one above the other.
13. System (1) according to one or more of claims 1 to 11, wherein said at least one magazine (5,7) comprises a monorail assembly (53,73) to which said fluid transportation means (25) can be connected.
14. Method of delivery of fluids using the system according to claim 1, in particular coloured fluids, adapted to implement a dosage process wherein containers (B_n) are filled up in order to obtain a finished product according to a given formula, said formula being representative of the dosage and/or composition of one or more fluids, said method comprising the steps of:
 - picking up, through a robot (9), a delivery valve (V_m) from a storage point (D_m) of at least one magazine (5,7) comprising a cable drag chain (51,71) that comprises coupling means (52,72) adapted to connect said fluid transportation means (25) to said tank of said at least one magazine (5,7) and placing it at a dosage point (E_j) of at least one dosage line (3);
 - commanding the delivery of said fluid, through a delivery actuator (E_i), into a first container (B_n) which is present at a station (S_p) of said at least one dosage line (3).
15. Method according to claim 14, wherein it is envisaged to:
 - move said first container (B_n) from a first station

- to a second station;
 - place a second container (B_n) at the entry (13) of said at least one dosage line (3);
 - repeat the previous steps until said formula is completed, i.e. until one wants to end said dosage process;
 - associate a fluid with at least one station (S_p), said association remaining valid throughout the duration of said dosage process.
16. Method according to claim 15, wherein said dosage process ends when a preset number of containers (B_n) filled up in accordance with said formula has been reached.
17. Method according to one or more of claims from 14 to 16, wherein it is envisaged to wash at least one of said delivery valves (V_m) at the end of said dosage process.
18. Method according to one or more of claims from 14 to 17, wherein it is envisaged to bring said delivery valves (V_m) back to their respective storage points (D_m), by means of said robot (9), at the end of said dosage process.
19. Method according to claim 18, wherein said step of bringing said delivery valves (V_m) back to their respective storage points (D_m) is carried out in reverse order compared to the order in which said delivery valves (V_m) were picked up from their storage point (D_m).
20. Method according to one or more of claims from 15 to 19, wherein said step of moving said first container (B_n) from a first station to a second station is carried out by said robot (9) during the dosage process.
21. Computer program product which can be loaded into a memory of said control unit (11) and which is adapted to implement the method according to one or more of claims from 14 to 20.

Patentansprüche

1. System (1) zur Abgabe von Fluiden, insbesondere farbigen Fluiden, das angepasst ist, einen Dosierprozess durchzuführen, wobei Behälter (B_n) gefüllt werden, um ein Endprodukt gemäß einer gegebenen Formel zu erhalten, wobei die Formel für die Dosierung und/oder Zusammensetzung eines oder mehrerer Fluide repräsentativ ist, wobei das System (1) umfasst:
- mindestens eine Dosierlinie (3) mit mindestens einer Station (S_p);
 - mindestens ein Magazin (5,7) mit Abgabever-

tilen (V_m), wobei ein Speicherpunkt (D_m) jedem von ihnen zugeordnet ist, und wobei sie mit einem Tank, der ein Fluid enthält, mittels Fluidtransportmitteln (25,26) verbunden sind;
 - einen Roboter (9), der angepasst ist, mindestens eines der Abgabeventile (V_m) vom Speicherpunkt (D_m) aufzunehmen und es an einem Dosierpunkt der mindestens einen Station (S_p) zu platzieren;
 - einer Steuereinheit (11), die angepasst ist, die mindestens eine Dosierlinie(3), das mindestens eine Magazin (5,7) und den Roboter (9) zu steuern und zu überwachen,

wobei das System (1) **dadurch gekennzeichnet ist, dass** das mindestens eine Magazin (5,7) eine Kabelschleppkette (51,71) umfasst, die Kupplungsmittel (52,72) umfasst, die angepasst sind, die Fluidtransportmittel (25) mit dem Tank des mindestens einen Magazins (5,7) zu verbinden.

2. System (1) nach Anspruch 1, wobei die mindestens eine Dosierlinie (3) mehrere Stationen (S_p) umfasst und eingerichtet ist, die Container (B_n) von einer ersten Station zu einer zweiten Station der mehreren Stationen (S_p) zu bewegen und die Steuereinheit (11) eingerichtet ist, das Fluid mit einer Station der mehreren Stationen (S_p) während der Dauer des Dosierprozesses zu assoziieren.
3. System (1) nach Anspruch 2, wobei die mindestens eine Station (S_p) eine Waage aufweist, die angepasst ist, das Gewicht eines Containers (B_n) während der Abgabe des Fluids zu bestimmen, und wobei die Steuereinheit (11) die Bewegung der Container (B_n) von der ersten Station zu der zweiten Station steuert, wenn das Fluid einen Grenzwert erreicht, der durch die Formel vorgegeben ist.
4. System (1) nach einem oder mehreren der vorhergehenden Ansprüche, wobei die Steuereinheit (11) die Abgabeventile (V_m) steuert, sobald sie an dem Dosierpunkt platziert worden sind, um während der Dauer des Dosierprozesses stationär zu bleiben.

5. System (1) nach einem oder mehreren der vorhergehenden Ansprüche, wobei die mindestens eine Station (S_p) ein Waschmodul (L_j) umfasst, das in Nähe zum Dosierpunkt angeordnet und angepasst ist, die Abgabeventile (V_m) am Ende des Dosierprozesses zu waschen.
6. System (1) nach dem vorhergehenden Anspruch, wobei das Waschmodul (L_j) angepasst ist, die Abgabeventile (V_m) am Ende des Dosierprozesses zu trocknen.

7. System (1) nach einem oder mehreren der vorhergehenden Ansprüche, wobei der Roboter (9) die Abgabeventile (V_m) zurück zu ihren entsprechenden Speicherpunkten (D_m) nach dem Ende des Dosierprozesses bewegt. 5
8. System (1) nach einem oder mehreren der vorhergehenden Ansprüche, wobei das mindestens eine Magazin (5,7) auf mindestens einer Seite der mindestens einen Dosierlinie (3) angeordnet ist. 10
9. System (1) nach einem oder mehreren der vorhergehenden Ansprüche, wobei der Roboter (9) frei ist, sich vorwärts und rückwärts in einer Längsrichtung und in einer Querrichtung der mindestens einen Dosierlinie (3) zu bewegen. 15
10. System (1) nach einem oder mehreren der vorhergehenden Ansprüche, wobei die mindestens eine Dosierlinie (3) Bewegungsmittel (31), insbesondere ein automatisches Förderband, umfasst, das angepasst ist, die Container (B_n) auf Haltemitteln der mindestens einen Dosierlinie (3) zu bewegen. 20
11. System (1) nach einem oder mehreren der Ansprüche 1 bis 9, wobei der Roboter (9) angepasst ist, die Container (B_n) auf Haltemitteln der mindestens einen Dosierlinie (3) zu bewegen. 25
12. System (1) nach Anspruch 1, wobei die Kupplungsmittel (52,72) vertikal bezogen auf eine Halteplatte des mindestens einen Magazins (5,7) und eines über dem anderen angeordnet sind. 30
13. System (1) nach einem oder mehreren der Ansprüche 1 bis 11, wobei das mindestens eine Magazin (5,7) eine Einschienenbahnordnung (53,73) aufweist, mit der die Fluidtransportmittel (25) verbunden werden können. 35
14. Verfahren zum Abgeben eines Fluids unter Verwendung eines Systems nach Anspruch 1, insbesondere farbiger Fluide, das angepasst ist, einen Dosierprozess durchzuführen, wobei Container (B_n) gefüllt werden, um ein Endprodukt gemäß einer gegebenen Formel zu erhalten, wobei die Formel für die Dosierung und/oder Zusammensetzung eines oder mehrerer Fluide repräsentativ ist, wobei das Verfahren die Schritte umfasst: 40
- Aufnehmen eines Abgabeventils (V_m) von einem Speicherpunkt (D_m) mindestens eines Magazins (5,7), das eine Kabelschleppkette (51,71) umfasst, die Kupplungsmittel (52,72) umfasst, die angepasst sind, die Fluidtransportmittel (25) mit dem Tank des mindestens einen Magazins (5,7) zu verbinden und sie an einem Dosierpunkt (E_i) mindestens einer Dosierlinie (3) zu platzieren, durch einen Roboter (9);
 - Steuern der Abgabe des Fluids durch einen Abgabeaktor (E_i) in einen ersten Container (B_n), der an einer Station (S_p) der mindestens einen Dosierlinie (3) angeordnet ist.
15. Verfahren nach Anspruch 14, wobei es vorgesehen ist zum: 45
- Bewegen des ersten Containers (B_n) von einer ersten Station zu einer zweiten Station;
 - Platzieren des zweiten Containers (B_n) am Eingang (13) der mindestens einen Dosierlinie (3);
 - Wiederholen der vorherigen Schritte bis die Formel vollständig ist, zum Beispiel bis jemand ein Ende des Dosierprozesses wünscht;
 - Assoziieren eines Fluids mit wenigstens einer Station (S_p), wobei die Assoziierung während der Dauer des Dosierprozesses gültig bleibt.
16. Verfahren nach Anspruch 15, wobei der Dosierprozess endet, wenn eine voreingestellte Anzahl von Containern (B_n), die in Übereinstimmung mit der Formel aufgefüllt wurden, erreicht worden ist.
17. Verfahren nach einem oder mehreren der Ansprüche 14 bis 16, wobei es vorgesehen ist, mindestens eines der Abgabeventile (V_m) am Ende des Dosierprozesses auszuwaschen.
18. Verfahren nach einem oder mehreren der Ansprüche 14 bis 17, wobei es vorgesehen ist, die Abgabeventile (V_m) zu deren entsprechenden Speicherpunkten (D_m) mittels des Roboters (9) nach dem Ende des Dosierprozesses zurückzubringen.
19. Verfahren nach Anspruch 18, wobei der Schritt des Zurückbringens der Abgabeventile (V_m) zu ihren entsprechenden Speicherpunkten (D_m) in umgekehrter Reihenfolge verglichen zu der Reihenfolge ausgeführt wird, in der die Abgabeventile (V_m) von ihrem Speicherpunkt (D_m) aufgenommen wurden.
20. Verfahren nach einem oder mehreren der Ansprüche 15 bis 19, wobei der Schritt des Bewegens des ersten Containers (B_n) von einer ersten Station zu einer zweiten Station durch den Roboter (9) während des Dosierprozesses ausgeführt wird.
21. Computerprogrammprodukt, das in einen Speicher der Steuereinheit (11) geladen werden kann und das angepasst ist, das Verfahren nach einem der Ansprüche 14 bis 20 auszuführen. 55

Revendications

1. Système (1) pour distribuer des fluides, en particulier

des fluides colorés, conçu pour mettre en oeuvre un procédé de dosage dans lequel des récipients (B_n) sont remplis de façon à obtenir un produit fini selon une formule donnée, ladite formule étant représentative du dosage et/ou de la composition d'un ou plusieurs fluides, ledit système (1) comprenant :

- au moins une ligne de dosage (3) comprenant au moins une station (S_p) ;
- au moins un magasin (5, 7) comprenant des robinets de distribution (V_m), dans lequel un point de stockage (D_m) correspond à chacun d'eux, et dans lequel ils sont reliés à un réservoir contenant un fluide par l'intermédiaire de moyens de transport de fluide (25, 36) ;
- un robot (9) conçu pour prendre au moins un desdits robinets de distribution (V_m) audit point de stockage (D_m) et le placer en un point de dosage de ladite au moins une station (S_p) ;
- une unité de commande (11) conçue pour commander et surveiller ladite au moins une ligne de dosage (3), ledit au moins un magasin (5, 7) et ledit robot (9),

ledit système (1) étant **caractérisé en ce que** ledit au moins un magasin (5, 7) comprend une chaîne porte-câble (51, 71) comprenant des moyens de couplage (52, 72) conçus pour relier lesdits moyens de transport de fluide (25) audit réservoir dudit au moins un magasin (5, 7).

2. Système (1) selon la revendication 1, dans lequel ladite au moins une ligne de dosage (3) comprend une pluralité de stations (S_p) et est configurée pour déplacer lesdits récipients (B_n) d'une première station à une deuxième station de ladite pluralité de stations (S_p), et ladite unité de commande (11) est configurée pour associer ledit fluide à une station de ladite pluralité de stations (S_p) pendant toute la durée dudit procédé de dosage.
3. Système (1) selon la revendication 2, dans lequel ladite au moins une station (S_p) comprend une balance conçue pour déterminer le poids d'un récipient (B_n) pendant la distribution dudit fluide, et dans lequel ladite unité de commande (11) commande le déplacement desdits récipients (B_n) depuis ladite première station à ladite deuxième station lorsque ledit fluide a atteint une valeur limite dictée par ladite formule.
4. Système (1) selon une ou plusieurs des revendications précédentes, dans lequel ladite unité de commande (11) commande lesdits robinets de distribution (V_m), une fois qu'ils ont été placés audit point de dosage, pour qu'ils restent fixes audit point de dosage pendant toute la durée dudit procédé de dosage.

5. Système (1) selon une ou plusieurs des revendications précédentes, dans lequel ladite au moins une station (S_p) comprend un module de lavage (L_j) disposé à proximité dudit point de dosage et conçu pour laver lesdits robinets de distribution (V_m) à la fin dudit procédé de dosage.
6. Système (1) selon la revendication précédente, dans lequel ledit module de lavage (L_j) est conçu pour sécher lesdits robinets de distribution (V_m) à la fin dudit procédé de dosage.
7. Système (1) selon une ou plusieurs des revendications précédentes, dans lequel ledit robot (9) replace lesdits robinets de distribution (V_m) à leurs points de stockage respectifs (D_m) après la fin dudit procédé de dosage.
8. Système (1) selon une ou plusieurs des revendications précédentes, dans lequel ledit au moins un magasin (5, 7) est disposé sur au moins un côté de ladite au moins une ligne de dosage (3).
9. Système (1) selon une ou plusieurs des revendications précédentes, dans lequel ledit robot (9) est libre de se déplacer vers l'avant et vers l'arrière dans une direction longitudinale et dans une direction transversale de ladite au moins une ligne de dosage (3).
10. Système (1) selon une ou plusieurs des revendications précédentes, dans lequel ladite au moins une ligne de dosage (3) comprend des moyens de déplacement (31), en particulier un convoyeur automatique, conçus pour déplacer lesdits récipients (B_n) sur des moyens de support de ladite au moins une ligne de dosage (3).
11. Système (1) selon une ou plusieurs des revendications 1 à 9, dans lequel ledit robot (9) est conçu pour déplacer lesdits récipients (B_n) sur des moyens de support de ladite au moins une ligne de dosage (3).
12. Système (1) selon la revendication 1, dans lequel lesdits moyens de couplage (52, 72) sont disposés verticalement par rapport à un plan de support dudit au moins un magasin (5, 7), et l'un au-dessus de l'autre.
13. Système (1) selon une ou plusieurs des revendications 1 à 11, dans lequel ledit au moins un magasin (5, 7) comprend un ensemble monorail (53, 73) auquel lesdits moyens de transport de fluide (25) peuvent être reliés.
14. Procédé de distribution de fluides utilisant le système selon la revendication 1, en particulier de fluides colorés, conçu pour mettre en oeuvre un procédé de dosage dans lequel des récipients (B_n) sont remplis

de façon à obtenir un produit fini selon une formule donnée, ladite formule étant représentative du dosage et/ou de la composition d'un ou plusieurs fluides, ledit procédé comprenant les étapes consistant à :

- prendre, au moyen d'un robot (9), un robinet de distribution (V_m) depuis un point de stockage (D_m) d'au moins un magasin (5, 7) comprenant une chaîne porte-câble (51, 71) qui comprend des moyens de couplage (52, 72) conçus pour relier lesdits moyens de transport de fluide (25) audit réservoir dudit au moins un magasin (5, 7) et le placer en un point de dosage (E_i) d'au moins une ligne de dosage (3) ;
- commander la distribution dudit fluide, au moyen d'un actionneur de distribution (E_i), dans un premier récipient (B_n) qui est présent au niveau d'une station (S_p) de ladite au moins une ligne de dosage (3).

15. Procédé selon la revendication 14, dans lequel il est envisagé de :

- déplacer ledit premier récipient (B_n) depuis une première station à une deuxième station ;
- placer un deuxième récipient (B_n) à l'entrée (13) de ladite au moins une ligne de dosage (3) ;
- répéter les étapes précédentes jusqu'à ce que ladite formule soit terminée, à savoir jusqu'à ce que l'on souhaite mettre fin audit procédé de dosage ;
- associer un fluide à au moins une station (S_p), ladite association restant valable pendant toute la durée dudit procédé de dosage.

16. Procédé selon la revendication 15, dans lequel ledit procédé de dosage prend fin lorsqu'un nombre prédéterminé de récipients (B_n) remplis selon ladite formule a été atteint.

17. Procédé selon une ou plusieurs des revendications 14 à 16, dans lequel il est envisagé de laver au moins un desdits robinets de distribution (V_m) à la fin dudit procédé de dosage.

18. Procédé selon une ou plusieurs des revendications 14 à 17, dans lequel il est envisagé de replacer lesdits robinets de distribution (V_m) à leurs points de stockage respectifs (D_m), au moyen dudit robot (9), à la fin dudit procédé de dosage.

19. Procédé selon la revendication 18, dans lequel ladite étape consistant à replacer lesdits robinets de distribution (V_m) à leurs points de stockage respectifs (D_m) est réalisée dans l'ordre inverse par rapport à l'ordre dans lequel lesdits robinets de distribution (V_m) ont été pris à leur point de stockage (D_m).

20. Procédé selon une ou plusieurs des revendications 15 à 19, dans lequel ladite étape consistant à déplacer ledit premier récipient (B_n) depuis une première station à une deuxième station est réalisée par ledit robot (9) pendant le procédé de dosage.

21. Programme informatique qui peut être chargé dans une mémoire de ladite unité de commande (11) et qui est conçu pour mettre en oeuvre le procédé selon une ou plusieurs des revendications 14 à 20.

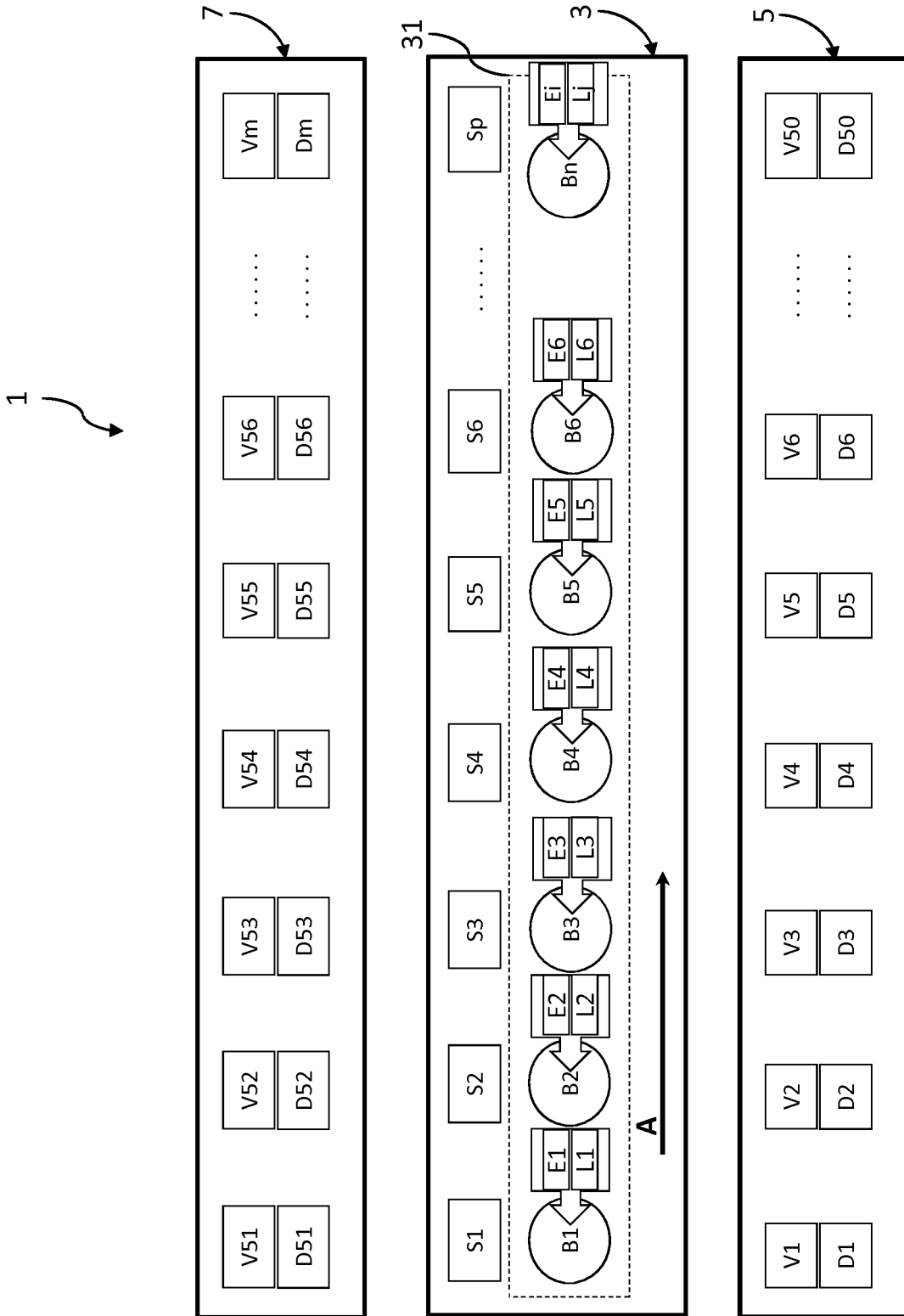

Fig. 1

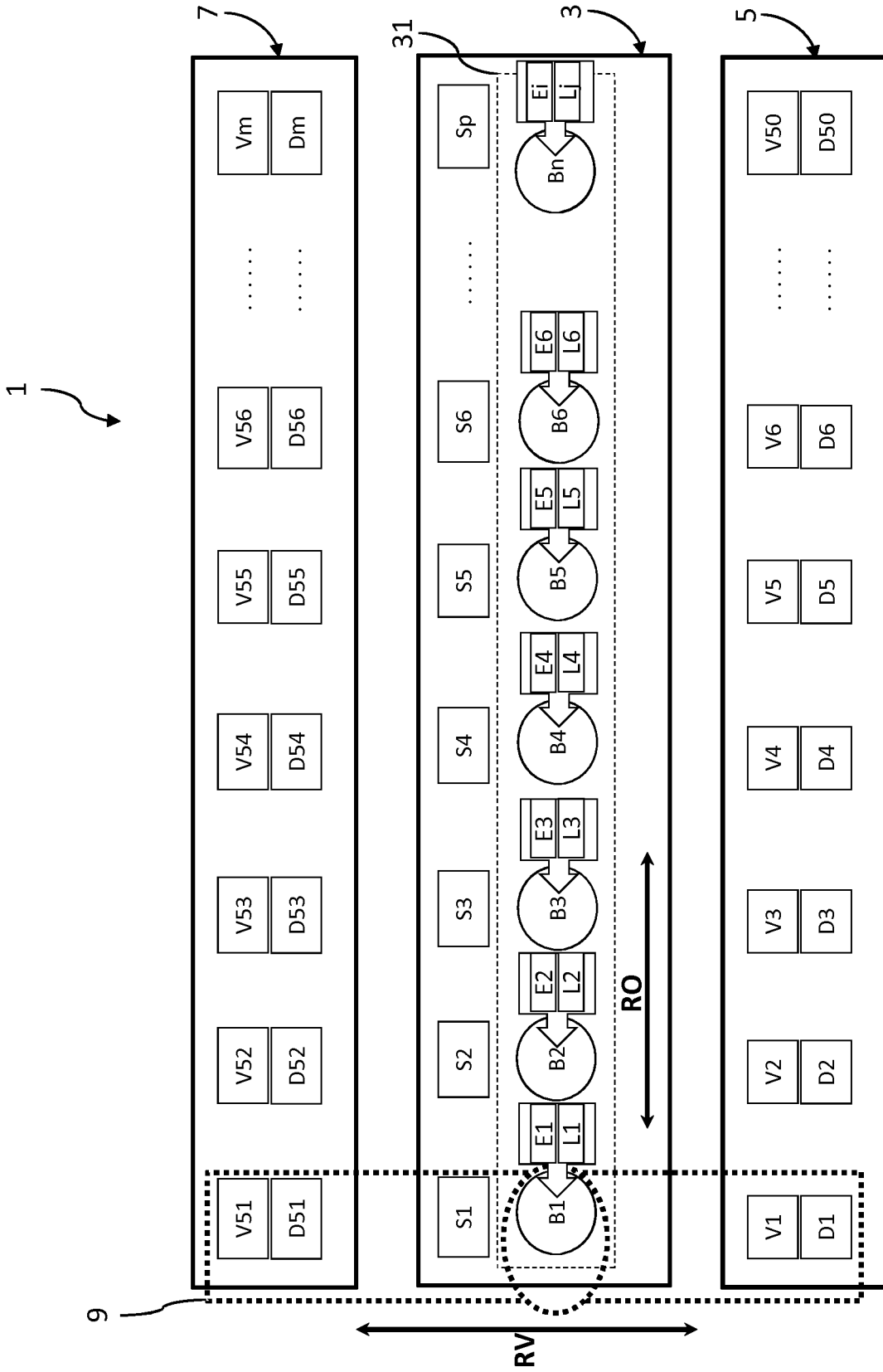

Fig. 2

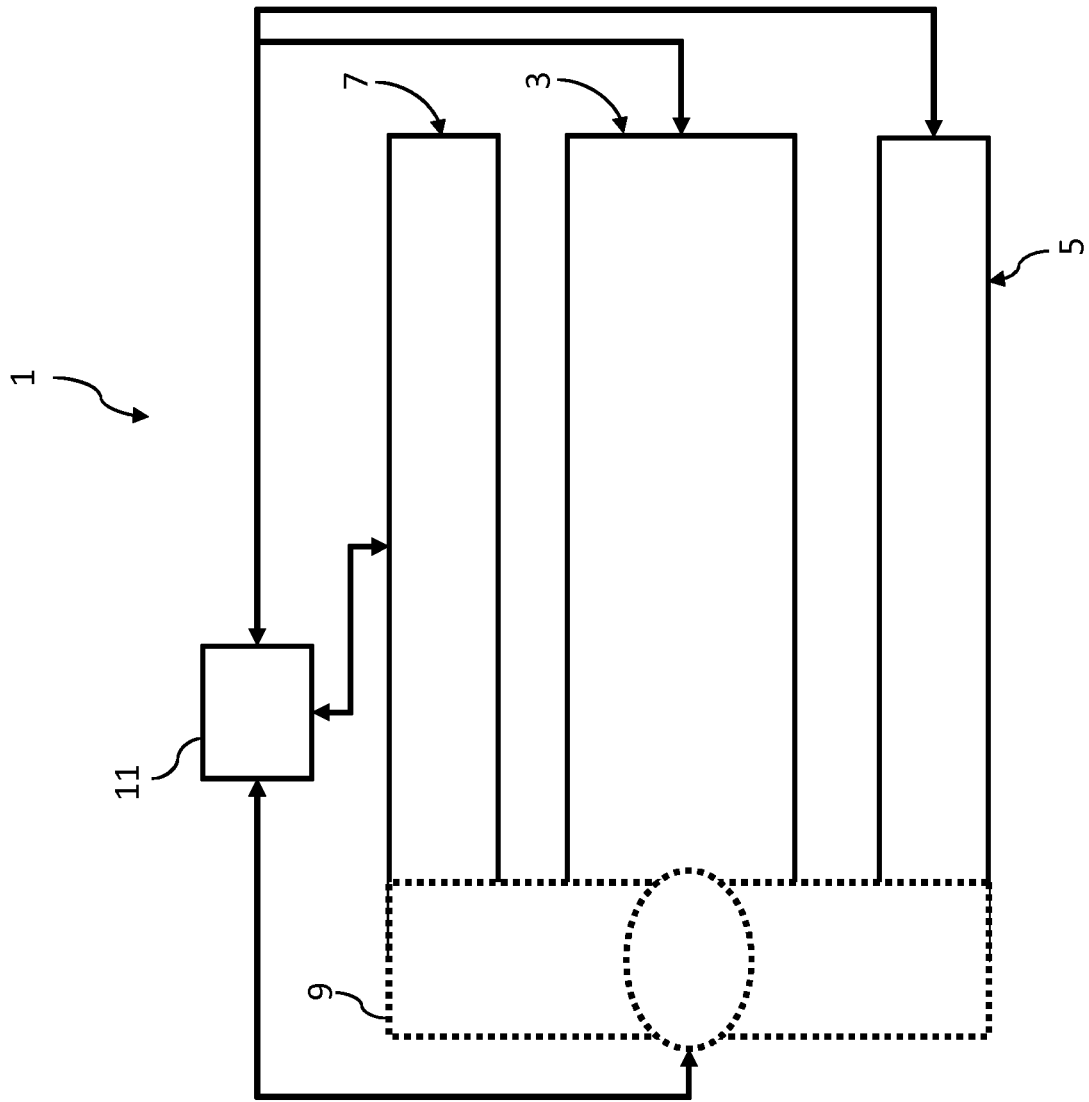

Fig. 3

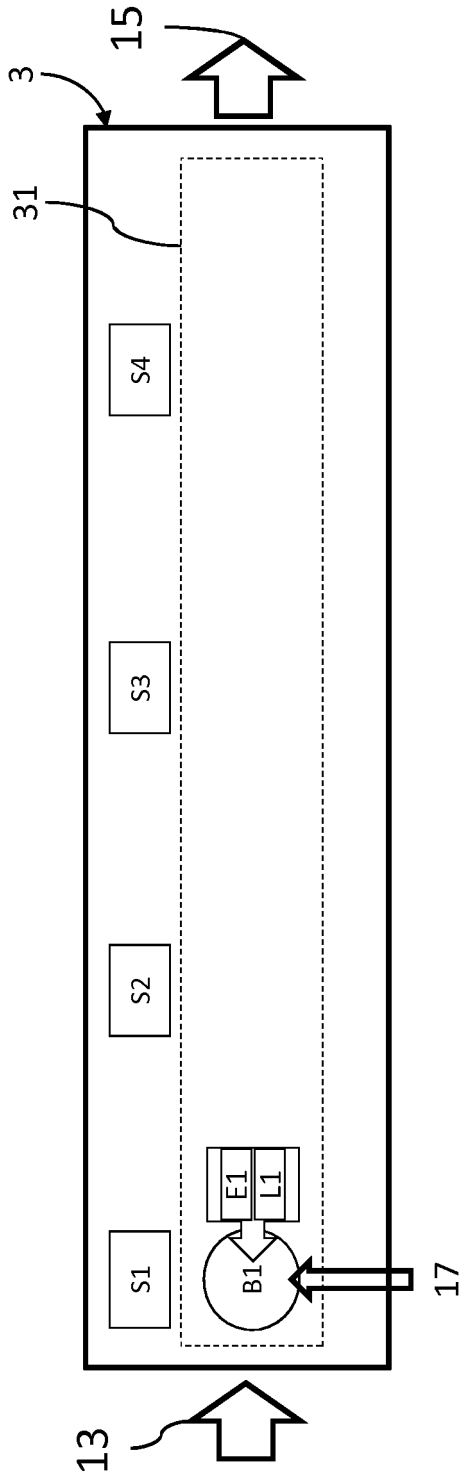

Fig. 4A

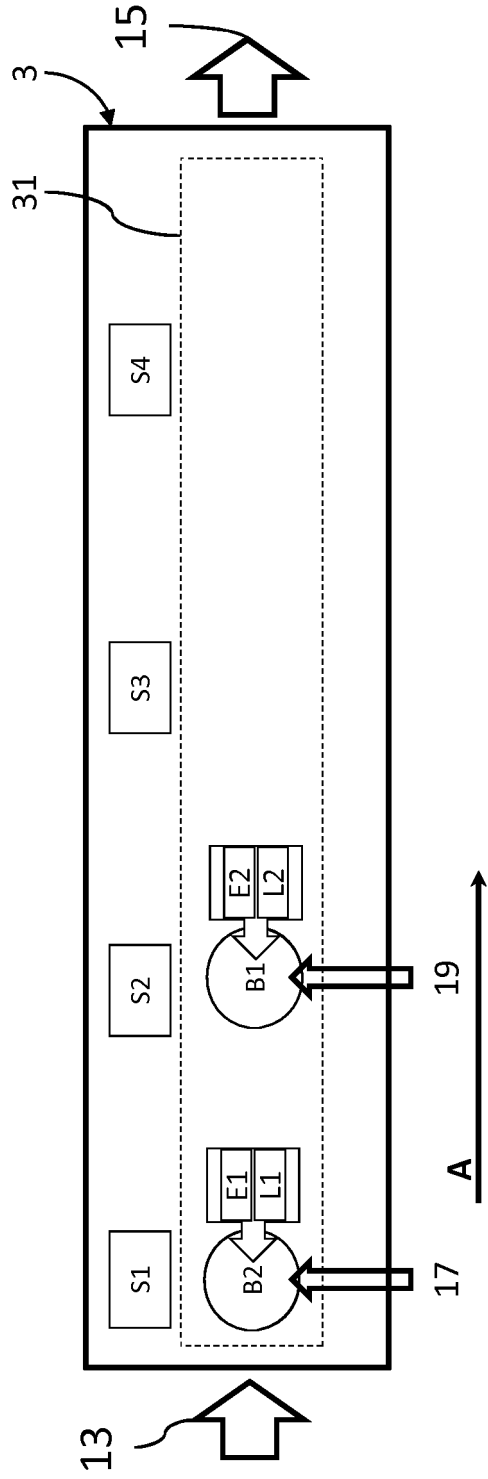

Fig. 4B

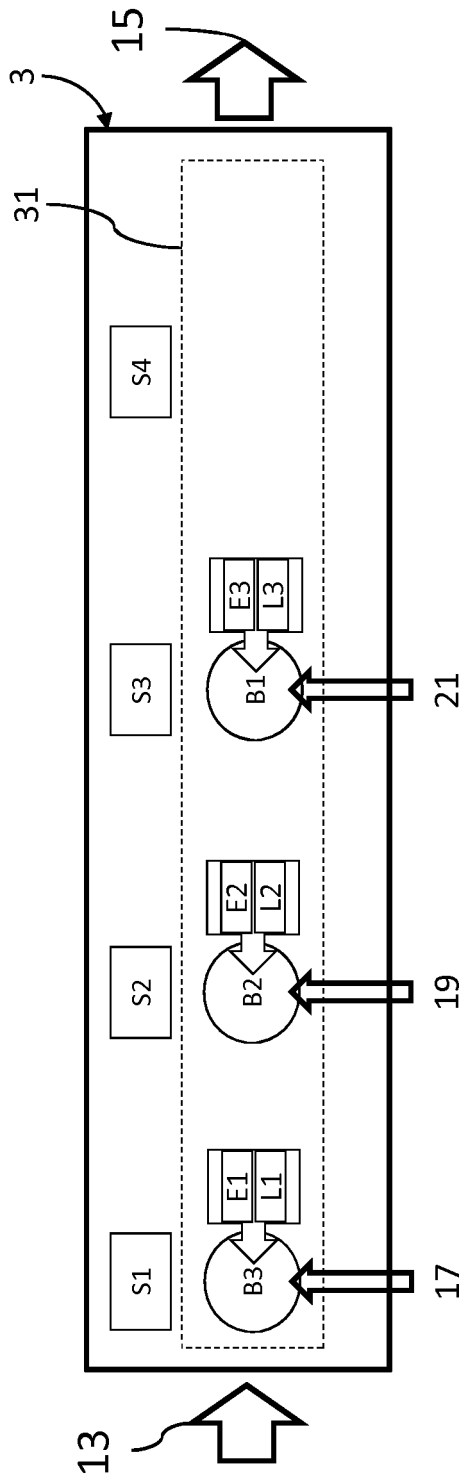

Fig. 4C

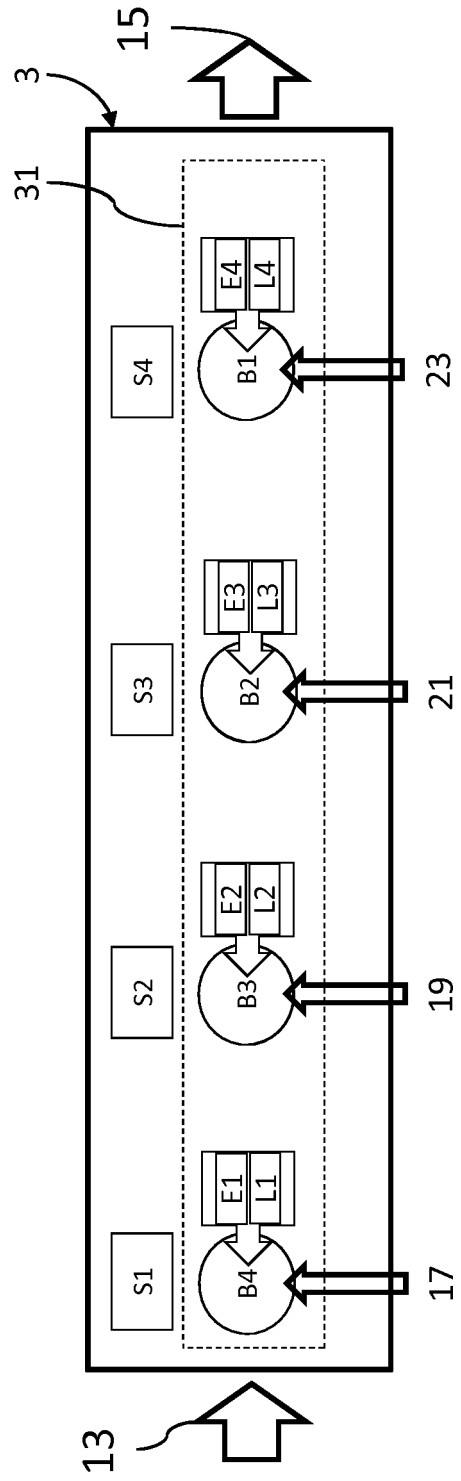

Fig. 4D

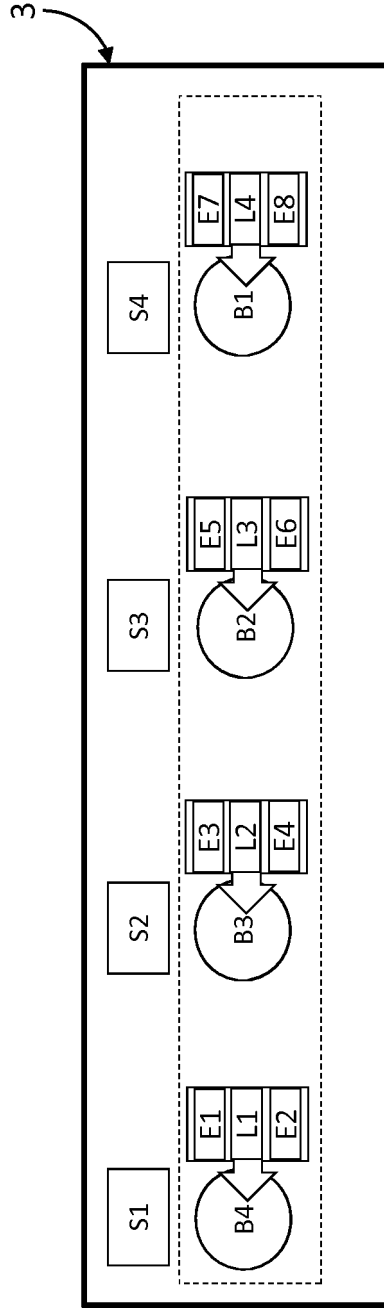

Fig. 4E

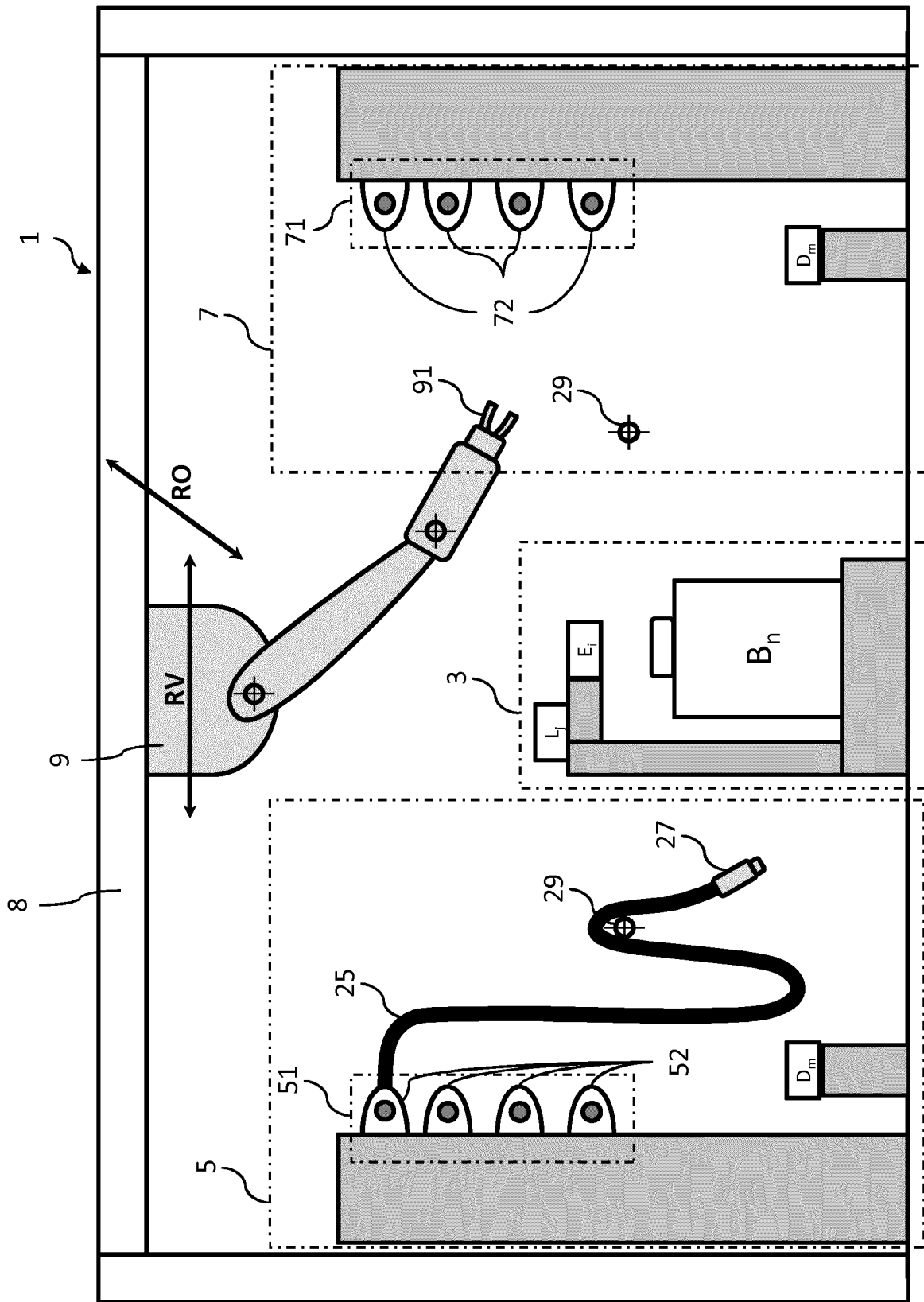

Fig. 5A

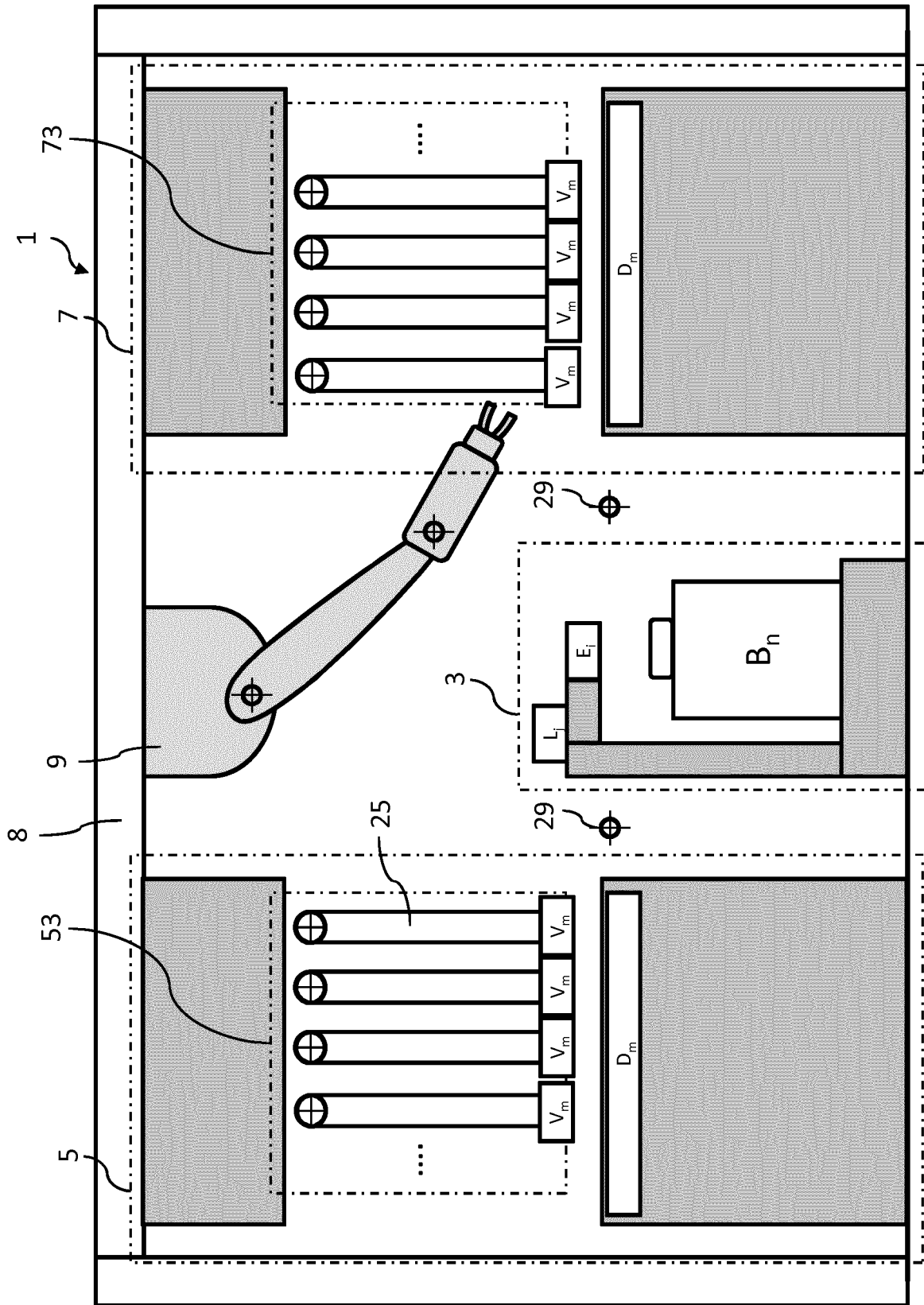

Fig. 5B

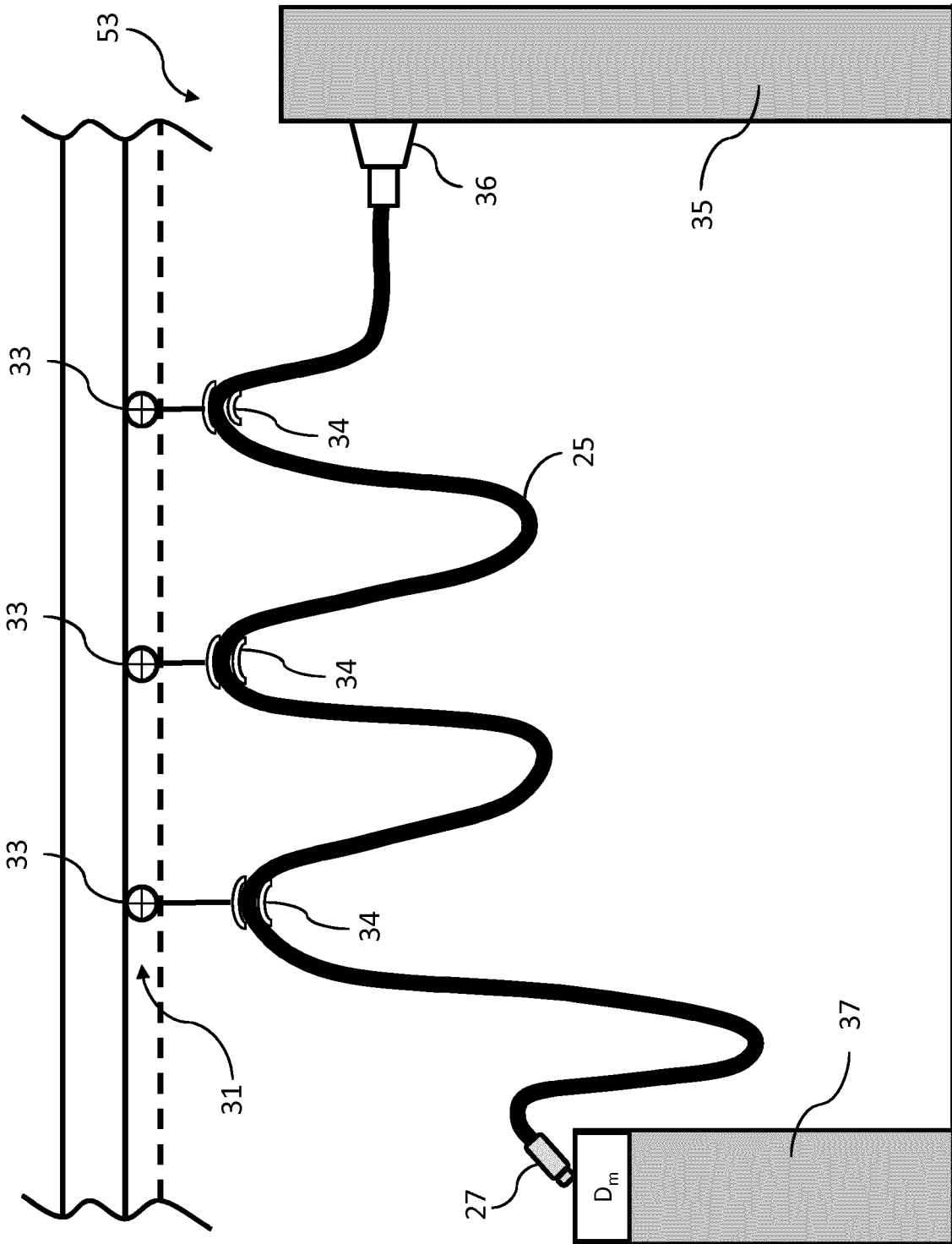

Fig. 5C

REFERENCES CITED IN THE DESCRIPTION

This list of references cited by the applicant is for the reader's convenience only. It does not form part of the European patent document. Even though great care has been taken in compiling the references, errors or omissions cannot be excluded and the EPO disclaims all liability in this regard.

Patent documents cited in the description

- US 4827993 A [0001]