

(19) World Intellectual Property  
Organization  
International Bureau



(43) International Publication Date  
20 January 2005 (20.01.2005)

PCT

(10) International Publication Number  
**WO 2005/006517 A1**

- (51) International Patent Classification<sup>7</sup>: **H02K 1/14**
- (21) International Application Number: PCT/IB2004/051199
- (22) International Filing Date: 12 July 2004 (12.07.2004)
- (25) Filing Language: English
- (26) Publication Language: English
- (30) Priority Data: 2003/01082 11 July 2003 (11.07.2003) TR
- (71) Applicant (for all designated States except US): **ARCELİK ANONİM ŞİRKETİ** [TR/TR]; E5 Ankara Asfaltı Uzeri, Tuzla, 34950 Istanbul (TR).
- (72) Inventors; and
- (75) Inventors/Applicants (for US only): **ACIKGOZ, Harun** [TR/TR]; Arcelik Anonim Sirketi, E5 Ankara Asfaltı Uzeri, Tuzla, 34950 Istanbul (TR). **EKIN, Cihat** [TR/TR]; Arce-lik Anonim Sirketi, E5 Ankara Asfaltı Uzeri, Tuzla, 34950 Istanbul (TR).
- (74) Agent: **ANKARA PATENT BUREAU**; Bestekar Sokak No.10, Kavaklıdere, 06680 Ankara (TR).
- (81) Designated States (unless otherwise indicated, for every kind of national protection available): AE, AG, AL, AM, AT, AU, AZ, BA, BB, BG, BR, BW, BY, BZ, CA, CH, CN, CO, CR, CU, CZ, DE, DK, DM, DZ, EC, EE, EG, ES, FI, GB, GD, GE, GH, GM, HR, HU, ID, IL, IN, IS, JP, KE, KG, KP, KR, KZ, LC, LK, LR, LS, LT, LU, LV, MA, MD, MG, MK, MN, MW, MX, MZ, NA, NI, NO, NZ, OM, PG, PH, PL, PT, RO, RU, SC, SD, SE, SG, SK, SL, SY, TJ, TM, TN, TR, TT, TZ, UA, UG, US, UZ, VC, VN, YU, ZA, ZM, ZW.
- (84) Designated States (unless otherwise indicated, for every kind of regional protection available): ARIPO (BW, GH, GM, KE, LS, MW, MZ, NA, SD, SL, SZ, TZ, UG, ZM, ZW), Eurasian (AM, AZ, BY, KG, KZ, MD, RU, TJ, TM), European (AT, BE, BG, CH, CY, CZ, DE, DK, EE, ES, FI, FR, GB, GR, HU, IE, IT, LU, MC, NL, PL, PT, RO, SE, SI, SK, TR), OAPI (BF, BJ, CF, CG, CI, CM, GA, GN, GQ, GW, ML, MR, NE, SN, TD, TG).
- Published:  
— with international search report

[Continued on next page]

(54) Title: MOTOR WITH MODULAR STATOR SEGMENTS

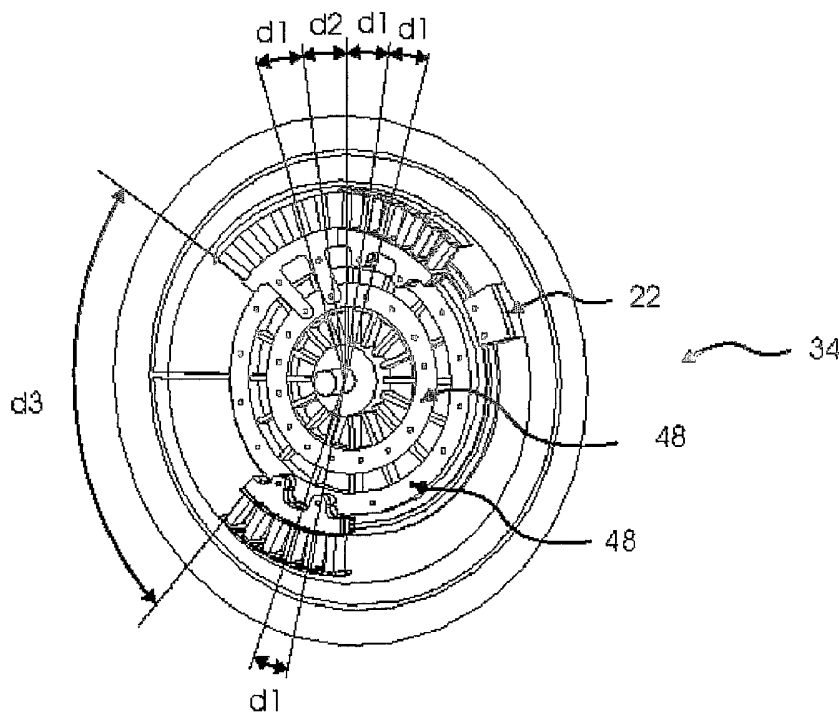

(57) Abstract: This invention is related to a motor (20), which operates at a desired number of torque and revolution by changing the quantity and the position of the stator segments (31).

WO 2005/006517 A1



---

*For two-letter codes and other abbreviations, refer to the "Guidance Notes on Codes and Abbreviations" appearing at the beginning of each regular issue of the PCT Gazette.*

## Description

### MOTOR WITH MODULAR STATOR SEGMENTS

- [001] The invention is related to a motor, which comprises a stator with attachable and detachable pieces.
- [002] In the state of art, the motors are designed to operate at a certain location where they provide the desired power, number of revolution etc., but when their location changes, producing a new motor with new parts, which are manufactured to meet the requirements of the new operating conditions is needed. For example, direct driven motors used in household appliances, particularly in washers/dryers, are designed respectively for each washer/dryer and can only be implemented to the washer/dryer that it's been designed for.
- [003] From the known embodiments of the art, in the US5818144 numbered American Patent, a linear motor is disclosed which utilizes more than one stator pieces instead of a circular shaped stator and which drives two sets of telescopic rotors and stators and a rotating drum.
- [004] The object of the invention is to provide a motor, which reaches the desired drive power by attaching and detaching many stator pieces which forms itself and which could be used in different appliances without the need of a special design.
- [005] The motor realized in order to attain the objects of this invention has been illustrated in the attached drawings, wherein;
- [006] Figure 1 – is a schematic view of a washer/dryer.
- [007] Figure 2 – is a perspective view of a tub on which a rotor and more than one stator group is placed.
- [008] Figure 3 – is a perspective view of a tub on which two stator groups are placed.
- [009] Figure 4 – is an exploded view of a motor comprising stator support on which a rotor, a sensor and more than one stator group is placed.
- [010] Figure 5 – is an exploded view of a stator wheel on which an adaptor part and more than one stator group is placed.
- [011] Figure 6 – is an exploded rear view of a rotor group.
- [012] Figure 7 – is a perspective front view of a stator support comprising more than one segment recesses.
- [013] Figure 8 – is a perspective front view of one or more stator segments, comprising many fixing points at different positions, which are fixed in the fixing points that are at different positions and a stator support on which a sensor is fixed .
- [014] Figure 9 – is a three dimensional front view of a stator segment.
- [015] Figure 10 – is a three dimensional rear view of a stator segment.
- [016] Figure 11 – is a three dimensional exploded view of a stator segment.
- [017] Figure 12 – is a perspective side by side view of two stator segments which have connection surfaces with fitting shapes to each other.

[018] The components in the figures have each been numbered corresponding the following:

- [019] 1. Household appliance
- [020] 2. Drum
- [021] 3. Tub
- [022] 4. Shaft
- [023] 20. Motor
- [024] 21. Control card
- [025] 22. Sensor
- [026] 30. Stator
- [027] 31. Stator segment
- [028] 32. Stack
- [029] 33. Winding
- [030] 34. Stator support
- [031] 35. Case
- [032] 36. Stator lamination
- [033] 37. Pole extension
- [034] 38. Winding roller
- [035] 39. Locking form
- [036] 40. Input socket
- [037] 41. Output socket
- [038] 42. Bridge
- [039] 43. Contact surface
- [040] 44. Contact extension
- [041] 45. Contact recess
- [042] 46. Segment recess
- [043] 47. Segment fixing point
- [044] 48. Wheel fixing point
- [045] 49. Stator outer surface
- [046] 60. Adapter part
- [047] 61. Adapter fixing point
- [048] 70. Rotor
- [049] 71. Rotor segment
- [050] 72. Rotor carrier
- [051] 73. Torque transmitter

[052] The motor (20), which is the subject of the invention, is used preferably in household appliances, particularly in washers /dryers comprising a drum (2) wherein laundry is put, a tub (3) wherein the drum (2) is placed and a shaft (4) which is connected with the drum or it is used in motor-driven bicycles.

[053] The motor (20) comprises a stator (30) which transforms the voltage it receives to a

magnetic field, a rotor (70) which moves with the field formed by the stator (30), a sensor which is required to determine the condition and the position of the stator (30) and the rotor (70) and a control card (21) which enables controlling the stator (30) and the rotor (70) of the motor.

- [054] The rotor (70) comprises even numbers of preferably two rotor segments (71) which has magnetic features for instance, lamination packet, which is made of magnetic materials or materials that could be magnetized, which is in a shape and/or number where it could form dipole, a rotor carrier (72) which is placed on rotor segments (71), a torque transmitter (73) which transmits torque to the parts to be rotated such as the drum (2) with the help of the driver of the rotor carrier (72), for example shaft (4), which is moved by the rotor segments (71).
- [055] The stator (30) comprises stator segments (31) having appropriate form to the rotor (70), fixed to other or used individually s at a required quantity and position according to the required motor (20) power, and or a stator support (34) which is fixed on stator segments (31) such as the tub (3).
- [056] In the preferred embodiment, the rotor segment (7) is composed of one or more magnets, the sensor(s) (22) are placed at an appropriate position and quantities in accordance to the rotor segments (71) and stator segments (31) quantity and position.
- [057] The stator segment (31) comprises one or more stacks (32) which composes itself, one or more windings (33) which are made by wrapping of insulated wires over the stacks (32) with copper link, a case (35) made of insulated material, preferably made of plastic, which prevents the stack (32) from coming out of its place, which enables fastening to stator support (34) thus preventing electrical leakage, one or more segment fixing points (47) which is shaped like a recess and/or an extension that enables fastening, a stator outer surface (49) which is shaped like a spring that ensures the air gap between itself and the rotor (70) to remain fixed peripherally at all condition.
- [058] Each of the stator segments (31), when they are required to be placed side by side with other stator segment, comprises a side contact surface (43) which enables side by side placement without leaving any gaps in between them in order to maintain continuity of flux and to prevent any loses, an input socket (40), which enables receiving the voltage that is transferred from the network voltage and/or from the previous stator segment (31), on the case (35) and which has a form appropriate to the required phase quantity, a conductive bridge (42) which carries the voltage from the input socket (40) to the other winding (33) which has the same phase in the stator segment (31), an output socket (41) which has a form appropriate to the phase quantity and which carries the voltage received from the network, the previous stator segment (31) or the bridge (42) to the next stator segment (31) and/or the network connection.
- [059] Stator support (34) comprises one or more wheel fixing points (48) which have a shape of a recess and/or an extension that is appropriate to the segment fixing point (47), which ensures through its position and surface shape the distance (d2) between

the middle axes of the windings (31) located at the point where the stator segments are placed adjacent to each other and the distance (d1) between the middle axes of the windings (33) to be equal, which ensures the distance (d3) between the stator segments (31) which are placed on itself that are not adjacent but next to each other and the distance (d1) between each middle axis of the winding (33) to be a whole number multiple, which establishes contact without leaving any gaps between the side contact surfaces in such a way that it prevents any losses in order to ensure the continuation of flux between the stator segments (31) which are placed adjacent to each other, which ensures the air gap between the stator segments (31) and the rotor (70) to remain fixed and which fastens the stator segments (31) and which prevents the stator segments (31) from coming out of their places after they are fastened.

[060] Stator segments (31) are fastened on the stator support (34) in order to reach the maximum possible number of torque and revolution, in a circular form which encircles the rotor (70), in a way that it forms a full circular shape or in a circular shape formed by the rotor (70) that encircles it for lower number of torque and revolution, in a way that it partially forms a circular shape that provides the maximum force, in a position and quantity where the magnetic forces which are brought about when the voltage required is applied to reach the desired number of torques and revolution damaging the appliance on which they are placed on is prevented. The total number of the windings (33), which are on the stator segments (31) are fixed on the stator support (34), are a whole number multiple of the phase number required to be applied. The total number of windings (33), which are on the stator segments (31) are fixed adjacent to each other on the stator support (34) are also a whole number multiple of the phase number required to be applied and the distances (d1) between the whole middle axis of the winding (33) which are fixed adjacently on the stator segments (31) are equal.

[061] The stack (32) comprises more than one stator laminations (36) that form itself by overlapping each other.

[062] The stator segments (31), preferably manufactured in standard sizes, which are mounted in such a way that the segment fixing points (47) correspond to the wheel fixing points (48) by means of snap-fit, locking and preferably screws, meets all of the terms easily and also provides mounting convenience. Thus, the cost and process of production is decreased.

[063] In the preferred embodiment of the invention, the stator segment (31) is composed of two stacks (32) which have winding (33) in between them and which are fastened to each other with tight fitting. In this embodiment, more than one stator laminations (36) which form one of the stacks (32), comprises a pole extension (37) wherein one end is connected to other extension while the other end remains open and a locking form (39) located at the end which remains open. The stator segment (31) comprises a winding roller (38), which enables, preferably with the help of the pole extension (37), to fasten on the winding. The other stack (32) which forms the stator segment (31) is comprised

of more than one lamination plates (36) which are connected to each other and which has a form appropriate to that of the case (35) which prevents the winding (33) from coming out of the pole extension (37) by having a form appropriate to the locking form (39).

[064] In this embodiment, stacks are formed by placing the stator laminations (36) one after the other at a desired quantity, fixing them together preferably by welding and/or by driving in pins. Apart from the stator laminations (36), winding (33) is formed by winding coil wire on winding roller (38) at a desired quantity. The coil wires on the winding are preferably coated with enameled material for insulation purposes. The winding roller (38) on the winding (33), is fixed on the pole extension (37), which is in the stack (32) and with the help of the locking form (39) both of the stacks (32) are rammed together. Thus, parting of the stacks (32) from each other and protruding of the windings (33) from their places, which are wedged in between, the stacks are prevented. After the prevention of the stacks (32) parting from each other, a case (35) is fixed on both ends and it is fastened on the stator support (34) with screws and the cable connections from the winding (33) are connected to each other, to the input socket (40) and the output socket (41).

[065] The edges of the contact surface (43) are formed by the side edges of the case (35) and the middle part is formed by the side surface of the stack (32). When the stator segment (31) is used side by side with another stator segment (31), the contact surface of the two stator segments are in contact with each other. The stator segments' (31) windings (33), which are placed side by side, are connected to each other with the help of the input socket (40) and output socket (41) according to the required pole structure and the phase difference.

[066] The motor, which is the subject of the invention, is designed both with a stator (30) comprised of one or more stator segments (31) which possess features, such as winding number, pole number, size etc., that provide the maximum number of torque and revolution that enables the household appliance to function and a rotor (70) which moves around the stator (30) and which is formed in a circular shape by the rotor segments (71) so that it encircles the circle formed by the stator (30) in a 360 degrees and it enables the household appliance (1) to operate at low power by placing stator segments (31), at a quantity less than the number of the stator segments (31) that could provide maximum power and equal to the required power, at appropriate quantities and positions in the same and/or different bodies without the need to make a different design even at powers lower than the maximum power.

[067] In the preferred embodiment, the positions of the sensor (22), preferably Hall Sensor, the rotor (70) and the stator (30) are determined in relation to each other, the data obtained is processed by means of a control card (21) and operating and controlling the motor (20) at desired revolutions is ensured. The sensor (22), which is preferably placed in plastic protector, is fastened on the drum (2) or on the tub (3). In

another embodiment of the invention, the sensor (22), during the production of the drum (2) which is preferably made of plastic, is placed in a casting and by being integrated with the material injected inside the casting it is taken out of the casting together with the drum (2) and it is used. The sensor (22) is placed in an appropriate quantity and positions according to the rotor segments' (71) and stator segments' (31) quantity and position.

[068] In another embodiment of the invention wherein the sensor (22) isn't used, the motor is preferably composed of a stator (30) and a rotor (70) which are placed in such a way that they operate at a fixed speed.

[069] The stator segments (31) of the motor (20), which is the subject of the invention, are placed preferably in a way that they are geometrically symmetrical to each other and that they divide a circle angularly into gaps with equal angles. In cases where they are not placed symmetrically or with equal angles, they are placed in positions and quantities wherein they possess geometry to damp the undesired forces that could take place.

[070] The motor (20), which is the subject of the invention, can be composed of one or more stator segments (31), which have the same windings (33) quantity or of stator segments (31), which have different wire coil quantities (turn number) or different winding (33) quantities appropriate to the used phase quantity. For example, in one of the embodiments of the invention, instead of a 3 stator segments (31) composed of 12 windings (33) which are placed at 120 degree angles, 4 stator segments (31) composed of 9 windings (33) which are placed at 90 degree angles could be used which is appropriate to the rotor (70) that is composed of one or more rotor segments (71), preferably magnets placed side by side and which has a circular shape that has a diameter same as the tub. These embodiments, if used in, for example, 3 phased voltage and wherein, for instance 1, 2, 3, codes are given for each phase, 12 units of windings (33) are connected to bridges which enable them to operate (42) in a "123123123123" manner and 9 units of windings (33) are connected to bridges which enable them to operate (42) in a "123123123" manner and where each stator segment's phase defined as "1" and the other stator segments phase defined as "1" are connected to each other through input socket (40) and output socket (41) and are connected to the network according to the defined codes.

[071] In another embodiment of the invention the stator support (34) comprises one or more segment recesses (46) which fastens the stator segments (31) and which prevents them from coming out of their places, which comprise a wheel fixing point (48) which has a shape of a recess and/or an extension that is appropriate to the segment fixing point (47) which ensures through its position and shape the distance (d2) between the middle axis of the winding (31) located at the point where the stator segments are placed adjacent to each other is equal to the distance (d1) between middle axis of the windings (33), which ensures the distance (d3) between the stator segments (31)

which are placed on itself that are not adjacent but next to each other, is equal to a whole number multiple of the distance (d1) between each middle axis of the windings (33) , which establishes contact without leaving any gaps between the side contact surfaces in such a way that it prevents any loses in order to ensure the continuation of flux between the stator segments (31) which are placed adjacent to each other, which ensure the air gap between the stator segments (31) and the rotor (70) to remain fixed, which are fixed on the stator segments (31), which has a form appropriate to the form of the stator segments (31) and which does not obstruct the stator segments' (31) operation or performance and their connection to each other according to the phase difference that is to be applied.

[072] In another embodiment of the invention, the stator support (34); comprises one or more adapter parts (60) which fastens the stator segments (31) and which prevents them from coming out of their places, which comprise a adapter fixing point (61) which has a shape of a recess and/or an extension that is appropriate to the segment fixing point (47) and wheel fixing point (48), which ensures through its position and shape the distance (d2) between the middle axis of the windings (31) located at the point where the stator segments are placed adjacent to each other is equal to the distance (d1) between windings (33), which ensures the distance (d3) between the stator segments (31) which are placed on itself that are not adjacent but next to each other is equal to a whole number multiple of the distance (d1) between each middle axis of the winding (33) , which establishes contact without leaving any gaps between the side contact surfaces in such a way that it prevents any loses in order to ensure the continuation of flux between the stator segments (31) which are placed adjacent to each other, which ensure the air gap between the stator segments (31) and the rotor (70) to remain fixed and which are fixed on the stator segments (31).

[073] In one embodiment of the invention, the stator segment (31) comprises a side contact surface (43), which has a contact recess (45) and/or a contact extension (44) which are appropriate to its shape and which ensures contact without leaving any gaps between themselves. Thus, when a stator segment (31) is side by side with another stator segment (31), the contact extension (44) and/or contact recess (45) on the side contact surfaces (43) are interconnected to each other and are fixed to each other in such a way that there are not any gaps. In this way, there are not any gaps between the stator segments (31) placed in the segment recesses (46) and thus the motor's (20) malfunction and low performance due to flux obstruction is prevented.

[074] In another embodiment of the invention, the stator segment (31) is composed of a single winding (33) fixed on the stack (32) and a single winding roller (38) and these stator segments (31) with single windings (33) compose stator segments (31) which are grouped by bringing them together side by side at a desired quantity and by placing the stator segments (31) at a desired quantity and at a position a motor with a desired power is obtained. In this embodiment, the windings (33) are connected to the network

and to each other in accordance to the phase to be applied.

[075] In addition to all these, by changing the number of windings of the wires which compose the winding (33) without effecting each others' placement, motors which have the same windings (33) and stator segments (31) and with different powers could be obtained.

[076] With the embodiment, which is the subject of the invention, design flexibility, production convenience and motors, which obtain torque and revolution values in a short period of time is provided. In addition to design and production conveniences, very important time and cost advantages are obtained in production and services as the parts, which compose the motor (20), such as the stator segment (31), stator support (34), and rotor segment (71), can be manufactured, stored and assembled at standard sizes.

## Claims

- [001] A motor (20) comprising a stator (30) which is preferably used in household appliances, particularly washer/dryers and which converts the voltage to a magnetic field, a rotor (70) which encircles the stator (30) and which is in a shape and/or number where it could form dipole that moves with the field formed by the stator (30), which is formed by the rotor segment (71) preferably out of double magnetic or magnetized material, characterized by a stator (30) comprising, a side contact surface (43) which provides continuity of flux by ensuring a connection without any gaps when placed adjacently to one another and which prevents any losses, a stator outer surface (49) which is shaped like arc that ensures the air gap between itself and the rotor (70) to remain fixed peripherally at all condition, one or more segment fixing points (47) which is shaped like a recess and/or an extension that enables fastening, one or more stack (32), for instance lamination packet, made out of a flux conductive material which forms itself, one or more stator segments (31) comprising one or more winding (33) which are made by winding the stacks (32) with copper bar or insulated wires and a stator support (34) which is in a circular shape formed by the rotor (70) that encircles it in order to reach the maximum possible number of torque and revolution, which is in a circular shape formed by the rotor (70) that encircles it in order to form a full circular shape or for a lower level torque and revolution number, in a way that it partially forms a circular shape that provides the maximum force, in a position and quantity where the magnetic forces which are brought about when the voltage required is applied to reach the desired number of torque and revolution damaging the appliance on which they are placed on is prevented; the total number of the windings (33), which are on the stator segments (31) are fixed on the stator support (34), are a whole number multiple of the phase number required to be applied is the total number of windings (33), which are on the stator segments (31) are fixed adjacent to each other on the stator support (34) are also a whole number multiple of the phase number required to be applied and the distance (d1) between the middle axis of the winding (33) which are fixed adjacently on the stator segments (31) is equal for whole windings (33).
- [002] A motor (20) comprising one or more wheel fixing points (48) which have a shape of a recess and/or an extension that is appropriate to the segment fixing point (47) which enables fastening the stator segments (31) and which prevents them coming out of their places, as defined in claim 1 characterized with a stator support (34) comprising one or more segment recesses (46), which ensures through its position and shape, the distance (d2) between the middle axis of the windings (33) located at the point where the stator segments (31) are placed adjacent to each other is equal to the distance (d1) between middle axis of the

- windings (33) , which ensures the distance (d3) between the stator segments (31) which are placed on itself that are not adjacent but next to each other, is a whole number multiple of the distance (d1) between each middle axis of the winding (33) , which establishes contact without leaving any gaps between the side contact surfaces (43) in such a way that it prevents any loses in order to ensure the continuation of flux between the stator segments (31) which are placed adjacent to each other, which ensure the air gap between the stator segments (3) and the rotor (70) to remain fixed, which are fixed on the stator segments (31), which has a form appropriate to the form of the stator segments (31) and which does not obstruct the stator segments' (31) operation or performance and their connection to each other according to the phase difference that is to be applied.
- [003] A motor (20) comprising one or more adapter fixing points (61) which fastens the stator segments (31) and which prevents the stator segments (31) from coming out of their places after they are fastened, which has shape of a recess and/or extension that are appropriate to the segment fixing point (47) and wheel fixing point (48), as defined in claim one characterized with a stator support (34) comprising one or more adapter parts (60), which ensures through its position and surface shape the distance (d2) between the middle axis of the windings (31) located at the point where the stator segments (31) are placed adjacent to each other, is equal to the distance (d1) between middle axis of the windings (33) , which ensures the distance (d3) between the stator segments (31) which are placed on itself that are not adjacent but next to each other is a whole number multiple of the distance (d1) between each middle axis of the windings (33) , which establishes contact without leaving any gaps between the side contact surfaces (43) in such a way that it prevents any loses in order to ensure the continuation of flux between the stator segments (31) which are placed adjacent to each other, which ensures the air gap between the stator segments (31) and the rotor (70) to remain fixed and which are fixed on the stator segments (31).
- [004] A motor (20) as defined in Claim 1 characterized by a stator support (34) comprising one or more wheel fixing points (48), which ensures through its position and surface shape the distance (d2) between the middle axis of the winding (31) located at the point where the stator segments are placed adjacent to each other, is equal the distance (d1) between middle axis of the windings (33) , which ensures the distance (d3) between the stator segments (31) which are placed on itself that are not adjacent but next to each other, is a whole number multiple of the distance (d1) between each middle axis of the windings (33) , which establishes contact without leaving any gaps between the side contact surfaces (43) in such a way that it prevents any loses in order to ensure the continuation of flux between the stator segments (31) which are placed adjacent to each other, which ensures the air gap between the stator segments (31) and the

- rotor (70) to remain fixed and which are fixed on the stator segments (31), which fastens the stator segments (31) and which prevents the stator segments (31) from coming out of their places after they are fastened, which has shape of a recess and/or extension that are appropriate to the segment fixing point (47).
- [005] A motor (20) as defined in any of the Claims 1-4 characterized by a stator segment (31) comprising a side contact surface (43) having a plane form.
- [006] A motor (20) as defined in any of the Claims 1-4 characterized by a stator segment (31) comprising a side contact surface (43) which has a contact recess (45) and/or a contact extension (44) which are appropriate to its shape and which ensures contact without leaving any gaps between themselves.
- [007] A motor (20) as defined in any of the Claims above characterized with one or more sensors (22) which determine the state and positions of the stator (30) and/or rotor (70) and which are placed in accordance to the rotor segment (71) and stator segments (31) quantity and position.
- [008] A motor (20) as defined in Claim 6 characterized with a control card (21), which enables controlling the stator (30) and the rotor (70) in any desired way by the data received from the sensors (22).
- [009] A motor (20) as defined in any of the Claims above characterized with a stator segment (31) comprising a case (35) made of insulated material, preferably made of plastic, which prevents the stack (32) from coming out of its place, which enables fastening thus preventing electrical leakage.
- [010] A motor (20) as defined in any of the Claims above characterized with a stack (32) comprising more than one stator lamination (36) that is formed by overlapping each other.
- [011] A motor (20) as defined in Claim 10 characterized with a stator lamination (36) comprising a pole extension (37), which forms the stack (32) by joining together, wherein one end is connected to each other whilst the other remains open and a locking form (39) located at the end which remains open.
- [012] A motor (20) as defined in Claim 11 characterized with a stator segment (31) comprising a winding roller (38), which enables the winding (33) to be fixed on the pole extension (37).
- [013] A motor (20) as defined in Claim 12 characterized with a stator segment (31) which are placed side by side and which are connected to each other with the help of the input socket (40) and output socket (41) according to the required pole structure and the phase difference, comprises an input socket (40) which has a form appropriate to the required phase quantity, which enables receiving the voltage that is transferred from the network voltage on the case (35) and/or from the previous stator segment (31), a conductive bridge (42) which carries the voltage from the input socket (40) to the other windings (33) which has the same phase in the stator segment (31), which comprises an output socket (41) which

has a form appropriate to the phase quantity and which carries the voltage received from the network, the previous stator segment (31) or the bridge (42) to the next stator segment (31) and/or the network connection,

- [014] A motor (20) as defined in Claim 1-13 characterized with a stator segment (31), which are placed symmetrically to each other in order to prevent its body to be exposed to unwanted forces.
- [015] A motor (20) as defined in Claim 1-14 characterized with a stator segment (31) which are not symmetric to each other and which possess geometry to damp the undesired forces that could take place.
- [016] A motor (20) as defined in any of the Claims above characterized with a stator (30) which is connected to a drum (2) wherein laundry is put, a tub (3) wherein drum (2) is located, and a shaft (4) which is connected to the tub (3), which are used in washer/dryers, , and a rotor (70) which is placed on the tub (3) in such a way that it encircles stator (30) fixed on the tub (3) and which rotates the drum (2) by transferring the movement that it forms with shaft (4) that it is connected to.

[Fig. 001]

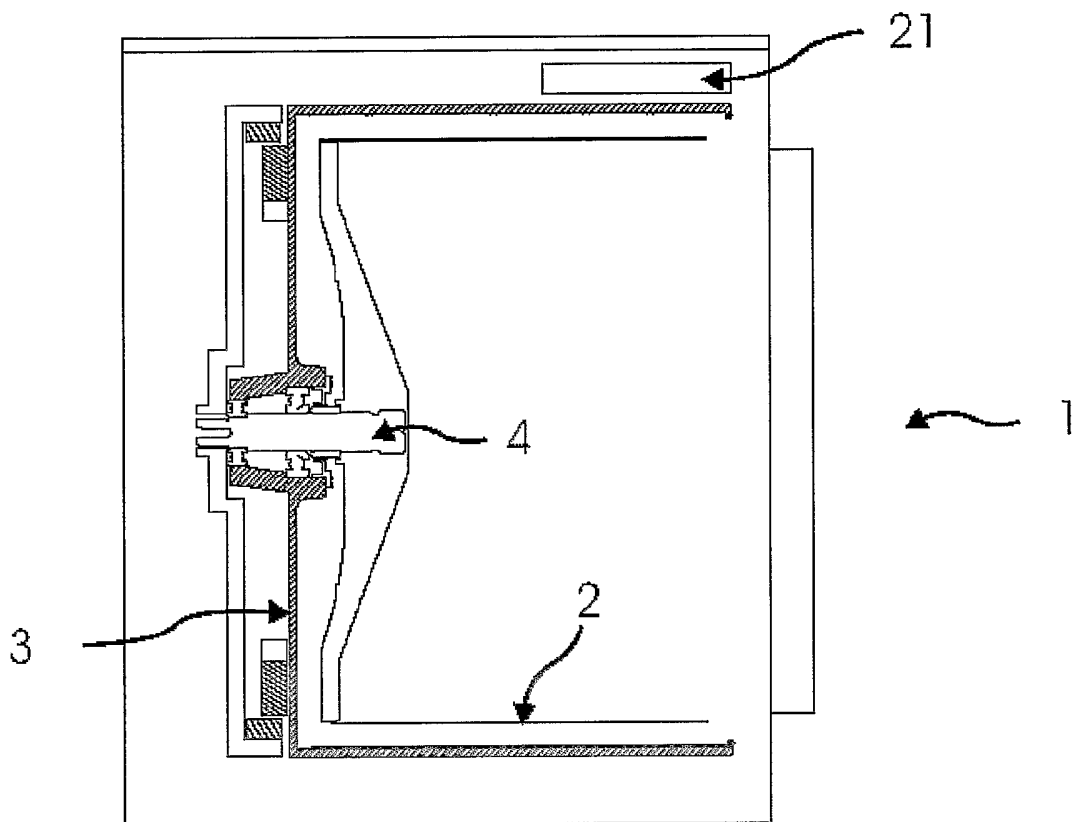

[Fig. 002]

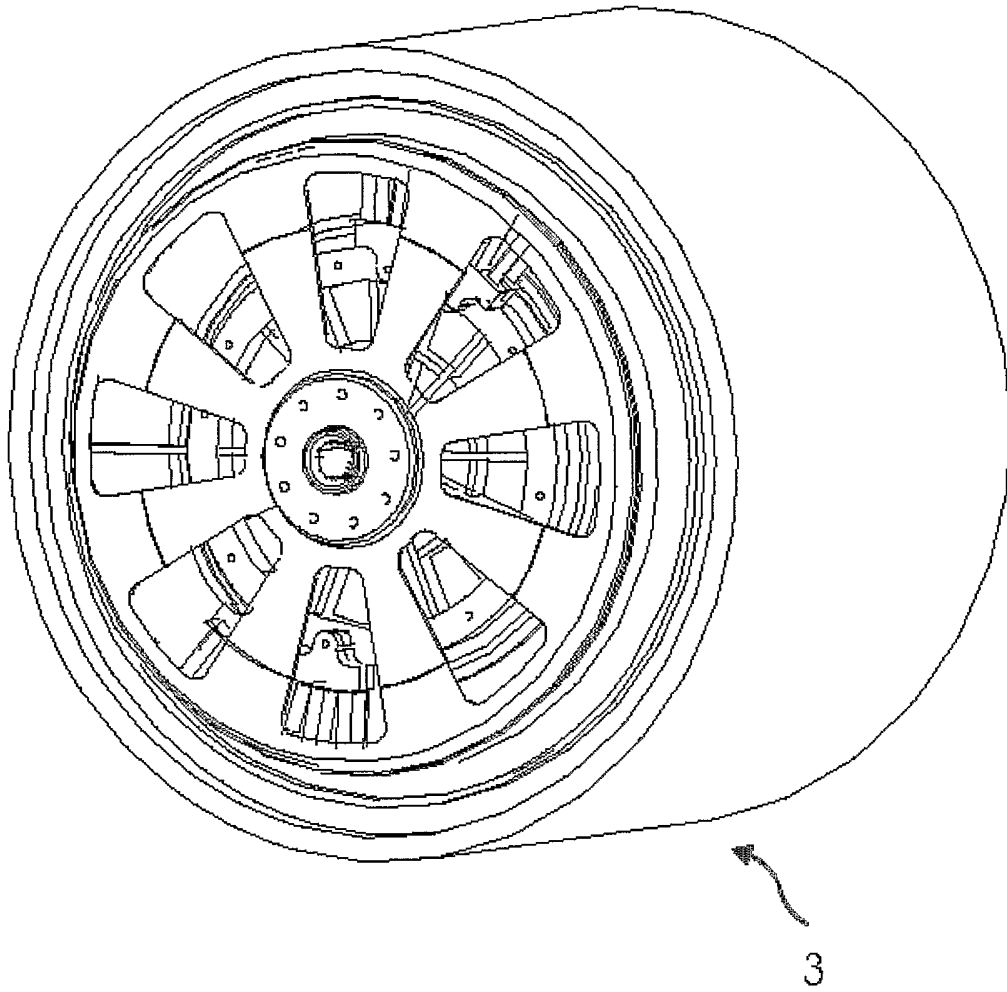

[Fig. 003]

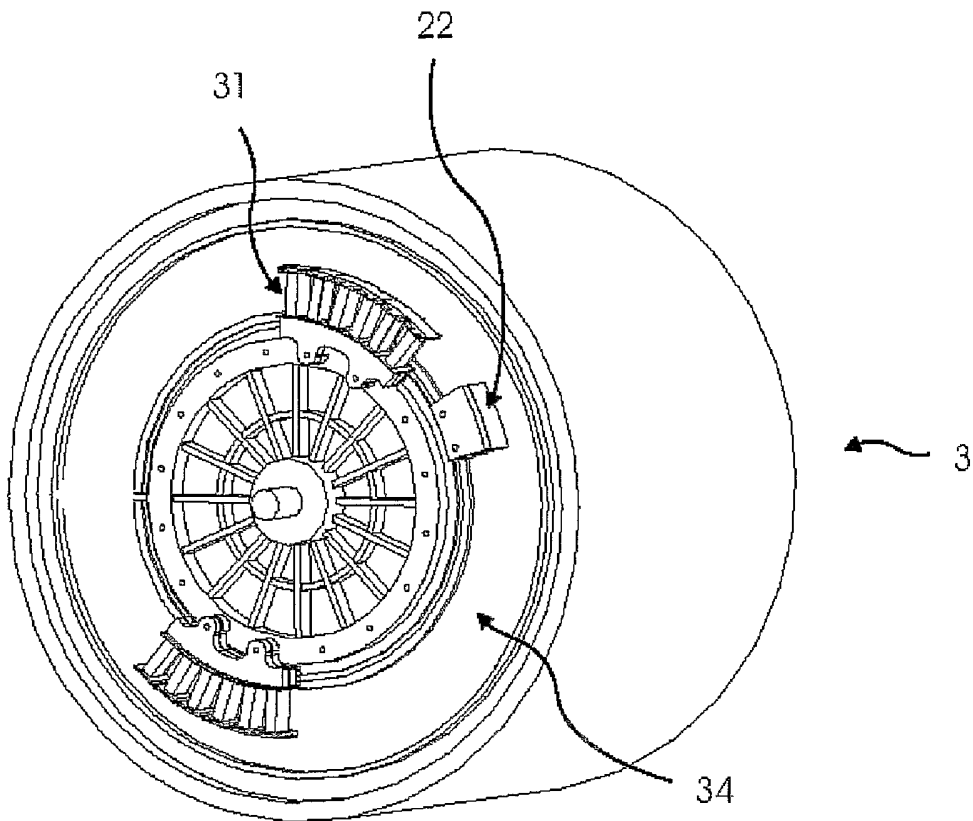

[Fig. 004]

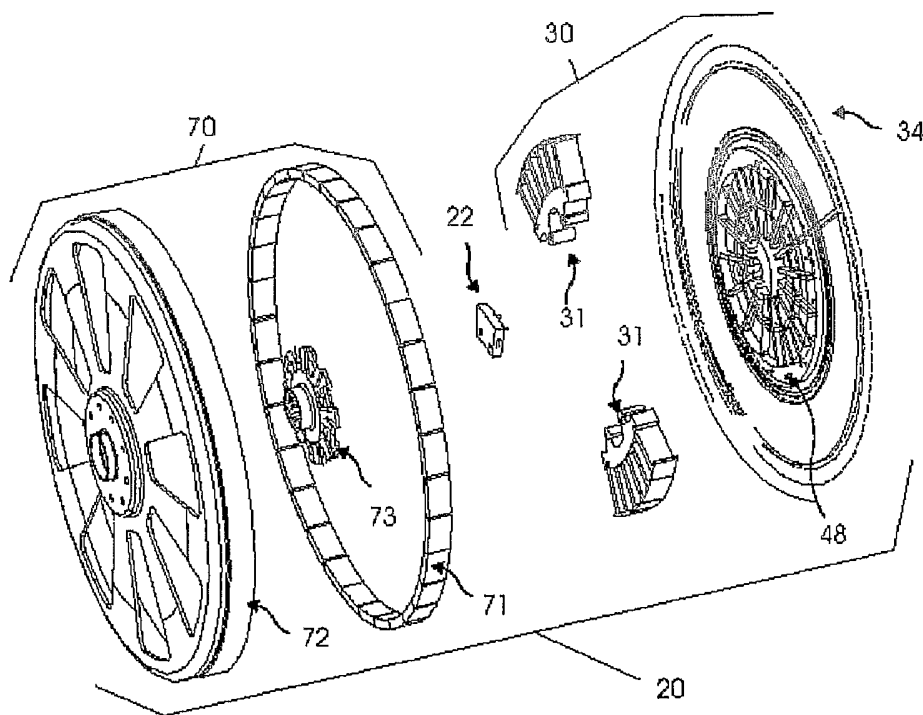

[Fig. 005]

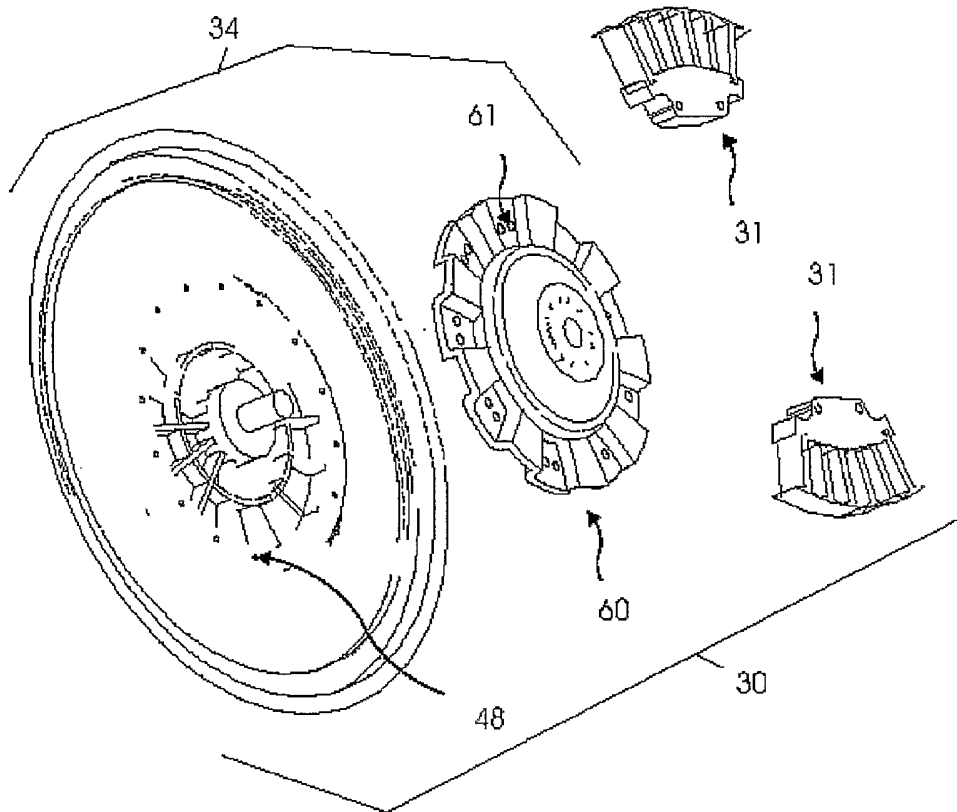

[Fig. 006]

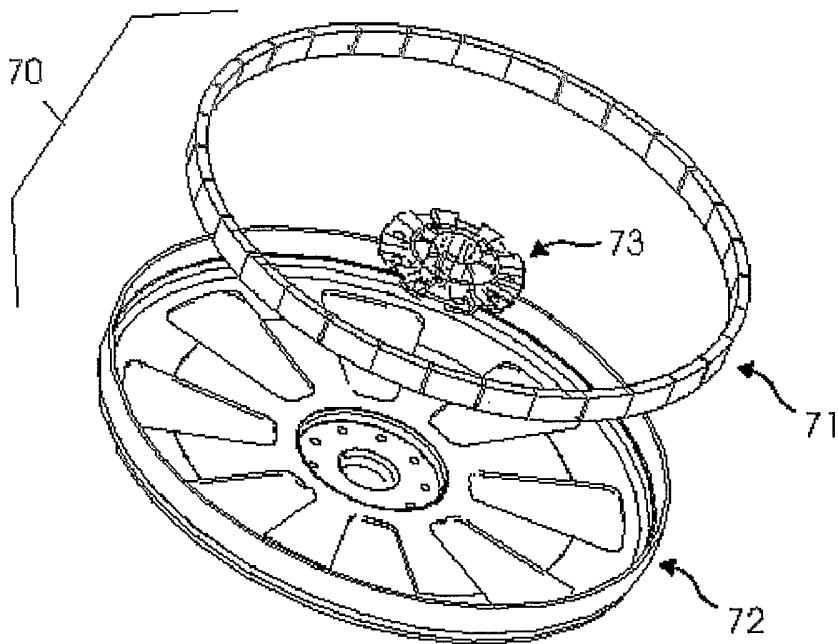

[Fig. 007]

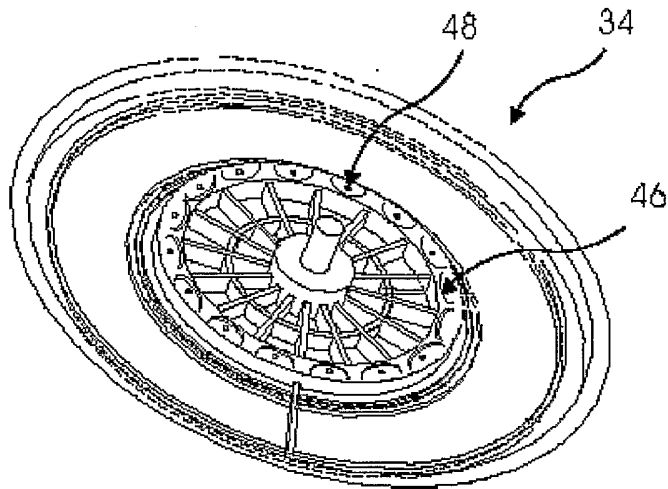

[Fig. 008]

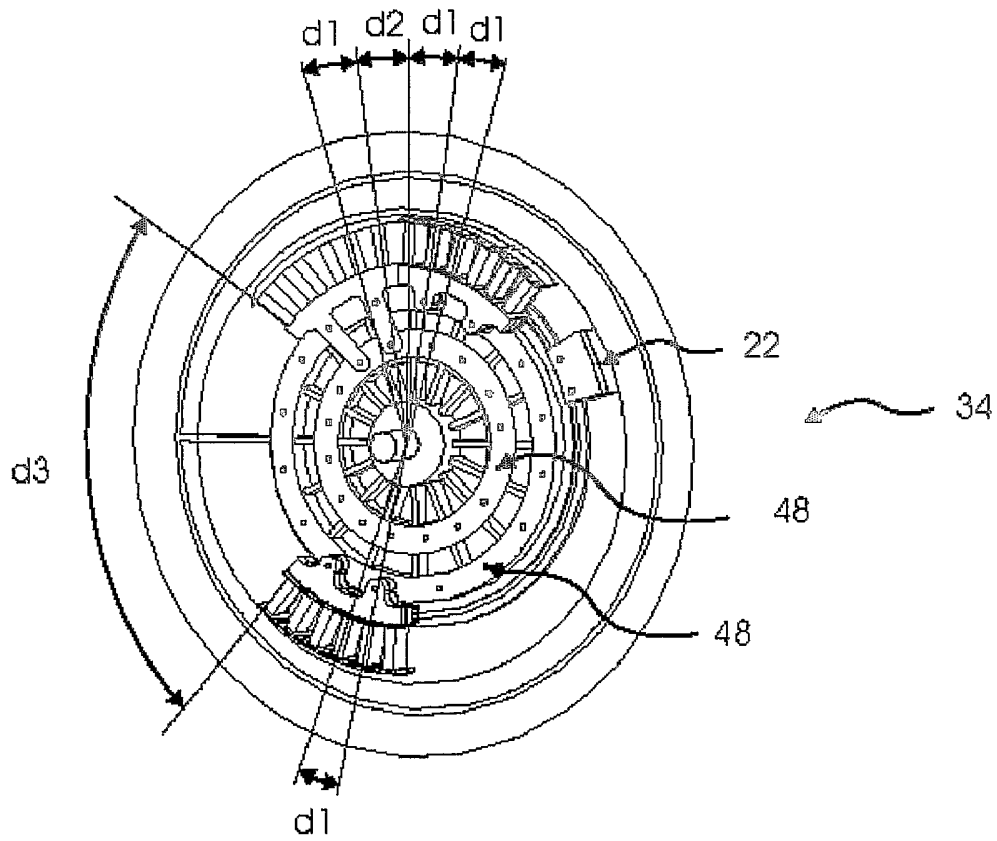

[Fig. 009]

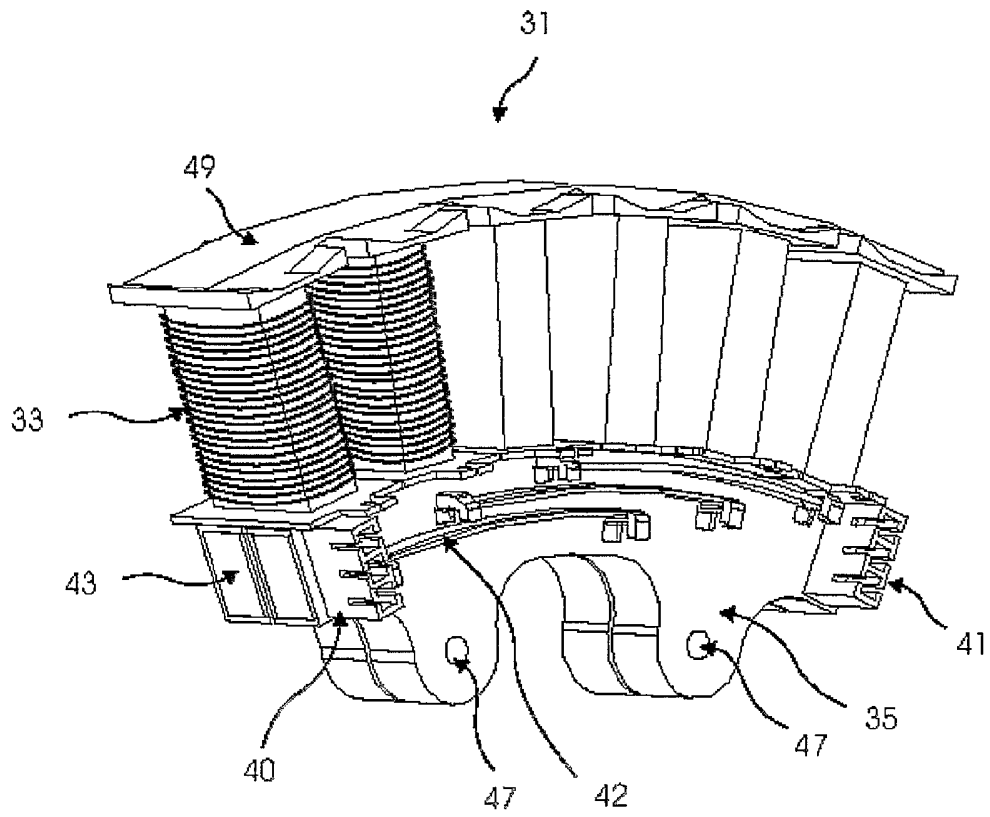

[Fig. 010]

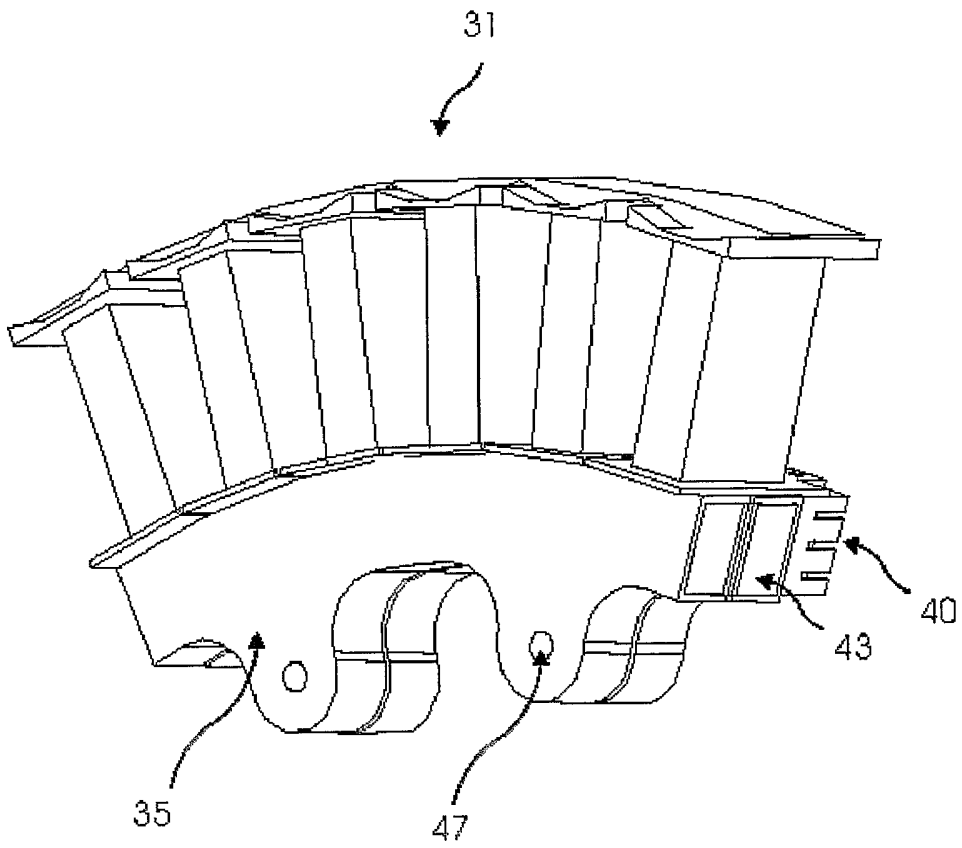

[Fig. 011]

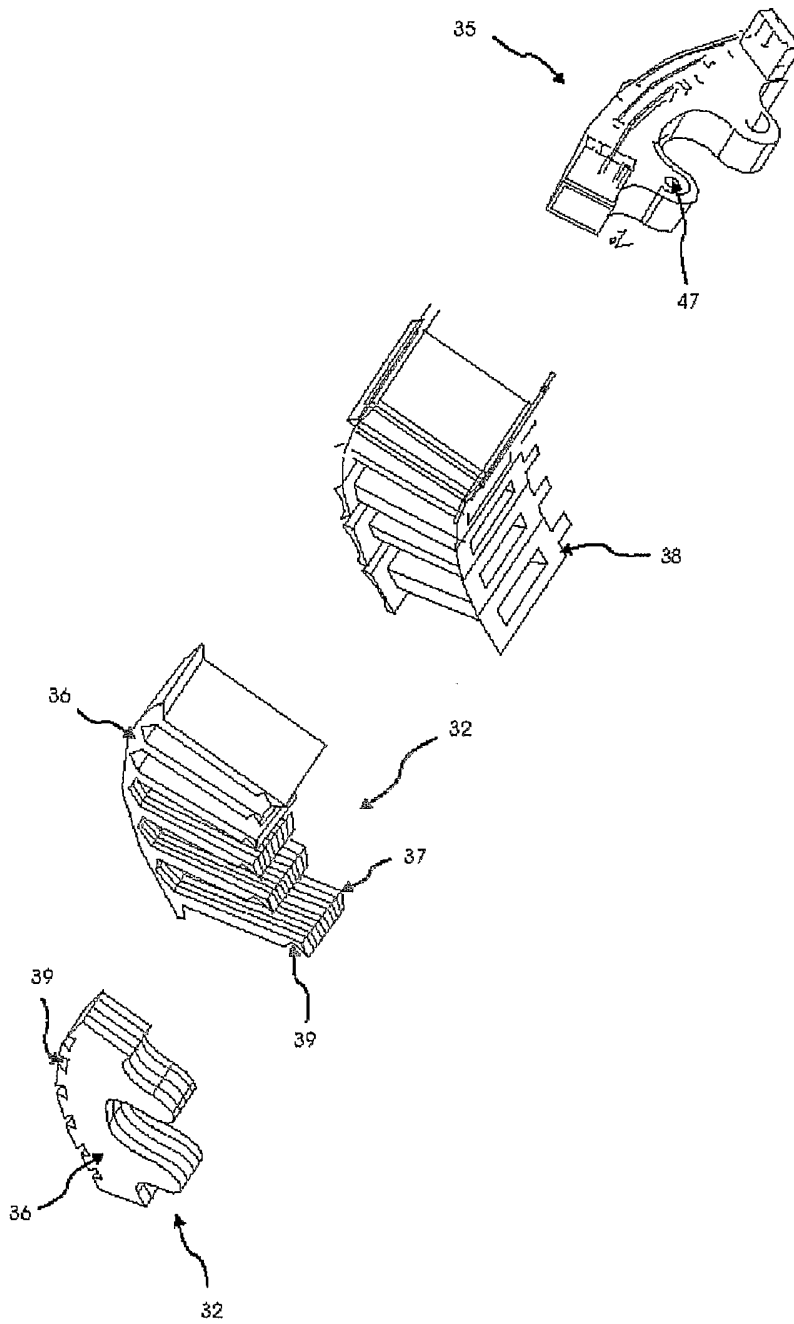

[Fig. 012]

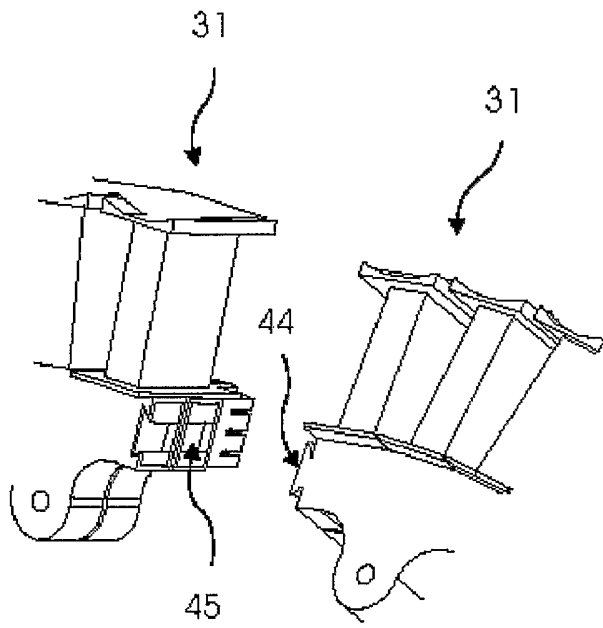

**INTERNATIONAL SEARCH REPORT**

International Application No

IB2004/051199

**A. CLASSIFICATION OF SUBJECT MATTER**

IPC 7 H02K1/14

According to International Patent Classification (IPC) or to both national classification and IPC

**B. FIELDS SEARCHED**

Minimum documentation searched (classification system followed by classification symbols)

IPC 7 H02K

Documentation searched other than minimum documentation to the extent that such documents are included in the fields searched

Electronic data base consulted during the international search (name of data base and, where practical, search terms used)

EPO-Internal

**C. DOCUMENTS CONSIDERED TO BE RELEVANT**

Category °	Citation of document, with indication, where appropriate, of the relevant passages	Relevant to claim No.
X	WO 03/047071 A (WAVECREST LAB LLC) 5 June 2003 (2003-06-05) figures 1-3,6 paragraph '0006! paragraph '0009! paragraph '0010! paragraph '0015!	1-16
X	US 2003/038556 A1 (ZALESSKI ANDREW ET AL) 27 February 2003 (2003-02-27) figures 8,11,14 paragraph '0003! paragraph '0069! - paragraph '0072! paragraph '0077! paragraph '0094!	1-16

Further documents are listed in the continuation of box C.

Patent family members are listed in annex.

° Special categories of cited documents :

- \*A\* document defining the general state of the art which is not considered to be of particular relevance
- \*E\* earlier document but published on or after the international filing date
- \*L\* document which may throw doubts on priority claim(s) or which is cited to establish the publication date of another citation or other special reason (as specified)
- \*O\* document referring to an oral disclosure, use, exhibition or other means
- \*P\* document published prior to the international filing date but later than the priority date claimed

- \*T\* later document published after the international filing date or priority date and not in conflict with the application but cited to understand the principle or theory underlying the invention
- \*X\* document of particular relevance; the claimed invention cannot be considered novel or cannot be considered to involve an inventive step when the document is taken alone
- \*Y\* document of particular relevance; the claimed invention cannot be considered to involve an inventive step when the document is combined with one or more other such documents, such combination being obvious to a person skilled in the art.
- \*&\* document member of the same patent family

Date of the actual completion of the international search

15 October 2004

Date of mailing of the international search report

28/10/2004

Name and mailing address of the ISA

European Patent Office, P.B. 5818 Patentlaan 2  
NL - 2280 HV Rijswijk  
Tel. (+31-70) 340-2040, Tx. 31 651 epo nl,  
Fax: (+31-70) 340-3016

Authorized officer

Le Chenadec, H

## INTERNATIONAL SEARCH REPORT

International Application No

IB2004/051199

C.(Continuation) DOCUMENTS CONSIDERED TO BE RELEVANT		
Category *	Citation of document, with indication, where appropriate, of the relevant passages	Relevant to claim No.
X	DE 100 36 339 A (BAYERISCHE MOTOREN WERKE AG) 7 February 2002 (2002-02-07) the whole document -----	1-16
A	DE 203 01 532 U (ZIEHL ABEGG AG) 3 April 2003 (2003-04-03) the whole document -----	1

# INTERNATIONAL SEARCH REPORT

Information on patent family members

International Application No

IB2004/051199

Patent document cited in search report	Publication date	Patent family member(s)	Publication date
WO 03047071	A	05-06-2003	US 2003193264 A1 16-10-2003
			CA 2464059 A1 05-06-2003
			EP 1446858 A2 18-08-2004
			WO 03047071 A2 05-06-2003
<hr/>			
US 2003038556	A1	27-02-2003	US 2001026101 A1 04-10-2001
			WO 03000017 A2 03-01-2003
			AU 5112401 A 15-10-2001
			WO 0176047 A2 11-10-2001
<hr/>			
DE 10036339	A	07-02-2002	DE 10036339 A1 07-02-2002
<hr/>			
DE 20301532	U	03-04-2003	DE 20301532 U1 03-04-2003
<hr/>			