

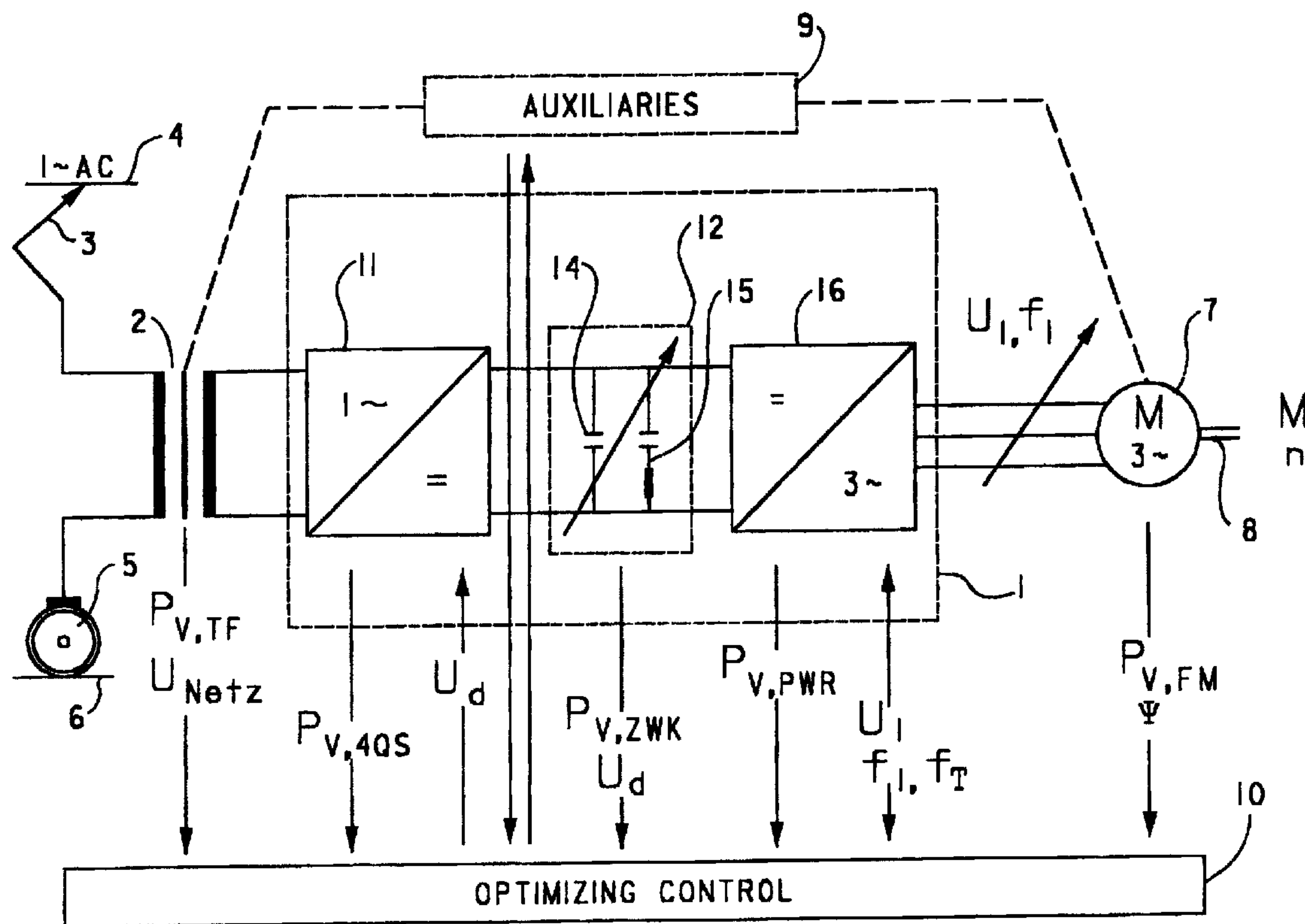

(86) Date de dépôt PCT/PCT Filing Date: 2000/07/04  
 (87) Date publication PCT/PCT Publication Date: 2001/01/18  
 (45) Date de délivrance/Issue Date: 2004/04/27  
 (85) Entrée phase nationale/National Entry: 2001/03/06  
 (86) N° demande PCT/PCT Application No.: EP 2000/006208  
 (87) N° publication PCT/PCT Publication No.: 2001/003965  
 (30) Priorité/Priority: 1999/07/07 (199 31 199.4) DE

(51) Cl.Int.<sup>7</sup>/Int.Cl.<sup>7</sup> B60L 15/20, B60L 9/28  
 (72) Inventeurs/Inventors:  
 KLOSE, CHRISTIAN, DE;  
 UNGER-WEBER, FRANK, DE  
 (73) Propriétaire/Owner:  
 BOMBARDIER TRANSPORTATION GMBH, DE  
 (74) Agent: FETHERSTONHAUGH & CO.

(54) Titre : PROCEDE DE COMMANDE D'UN SYSTEME D'ENTRAINEMENT DE PUISSANCE  
 (54) Title: METHOD FOR CONTROLLING A POWER DRIVE SYSTEM



(57) Abrégé/Abstract:

In order to minimize the energy required to operate a rail vehicle, within the drive system, which comprises an indirect converter 1 and a three-phase motor 7 that is supplied with power therefrom, the intermediate circuit voltage in the intermediate circuit 12 and/or the magnetic flux in the drive motor 7 are optimized according to the actual operating demands; optionally, the energy outlay for the auxiliaries 9 that cool these components is also included.

## Abstract

In order to minimize the energy required to operate a rail vehicle, within the drive system, which comprises an indirect converter 1 and a three-phase motor 7 that is supplied with power therefrom, the intermediate circuit voltage in the intermediate circuit 12 and/or the magnetic flux in the drive motor 7 are optimized according to the actual operating demands; optionally, the energy outlay for the auxiliaries 9 that cool these components is also included

21421-303

Method for Controlling a Power Drive System

The present invention relates to a method for controlling a high performance, variable-speed drive system.

DE 44 22 275 A1 describes a method for controlling  
5 a variable-speed, high-performance drive system in which two  
3-phase motors are each supplied with power by way of an  
associated pulse-type inverter from d.c. intermediate  
circuit that in its turn draws power from a supply network  
through a line rectifier. The drive motors produce a pull-  
10 out torque that always has to be greater than the torque  
that is to be produced. In addition, they must be designed  
for constant power consumption above a certain speed that is  
determined by the type point. In order to reduce  
interference variables such as oscillation moments or losses  
15 due to harmonic oscillations, in particular in the pulse-  
operation range, and thereby reduce the electrical and  
mechanical loads on the drive motors, as well as voltage  
stress on the indirect converter, in the speed range that is  
below the type point the intermediate circuit d.c. voltage  
20 is reduced in comparison to the maximally achievable  
intermediate circuit voltage, and in the speed range above  
the type point—starting from the reduced intermediate  
circuit voltage—it is raised in a speed-dependent transition  
to the maximal intermediate circuit voltage at the maximal  
25 speed of the drive motor. The line rectifier, which can be  
configured as a direct DC converter or as four-quadrant  
converters, are configured as four-quadrant converters when  
the drive motors also generate a retarding moment for the  
vehicle that is otherwise driven. In the driving mode, the  
30 motor voltages increase linearly from zero speed to the type  
point at a relatively constant magnetic flux, so that the  
maximal line voltage is reached at the type point. At motor

21421-303

speeds that are above the type point, the motor voltage remains constant when the flux decreases.

It is the objective of the present invention to describe a control method for controlling a high performance variable-speed drive system by means of which a much-improved energy balance for the drive system can be achieved.

According to the present invention, this objective has been achieved by method for controlling a high-performance, variable-speed drive system that comprises at least one drive motor and is designed for constant power consumption above a predetermined motor speed, and which is supplied with a variable intermediate circuit voltage through an indirect converter, said indirect converter being supplied with power from a power-supply network, the intermediate voltage being reduced relative to its maximal value in the motor-speed range above the predetermined motor speed, such that the intermediate circuit voltage is not reduced below minimal voltage that is determined by the supply network voltage during operation, and in the motor-speed range beneath the predetermined motor speed, proceeding from the reduced intermediate circuit voltage, there is a transition to maximal intermediate circuit voltage as a function of motor speed at maximal motor speed, in particular for rail vehicles that are supplied with driving energy from an electrical current collector or from the vehicle's dedicated diesel-electrical generator, characterized in that in the drive system, at motor speeds above the predetermined speed and up to the maximum speed, and in the lower range of the torque that is to be produced or retarded by the drive motor, the intermediate circuit voltage is held, at least largely, to the low value that it has below the predetermined motor speed.

21421-303

The invention also provides control system for controlling a high-performance, variable-speed drive system that comprises at least one drive motor and is designed for constant power consumption above a predetermined motor speed, and which is supplied with a variable intermediate circuit voltage through an indirect converter, the intermediate circuit voltage being reduced relative to its maximal value in the motor-speed range below the predetermined motor speed such that the intermediate circuit voltage is not reduced below a specific minimal voltage that is determined by the main power supply voltage (contact wire), and in the motor-speed range above the predetermined motor speed, proceeding from the reduced intermediate circuit voltage, there is a transition to the maximal intermediate circuit voltage at maximal motor speed, said transition being dependent on the motor speed, in particular for rail vehicles, characterized in that in the drive system, the intermediate circuit voltage at drive-motor speeds in block operation of the inverter and in the lower range of the torque that is to be generated or braked by the drive motor is, largely at least, to a value that corresponds to the intermediate circuit voltages in the intermediate circuit below the predetermined speed of the drive motor, and is so adjusted that there is a minimal loss of power for the overall drive system, at every working point.

The method according to the present invention takes account of the fact that, in the motor-speed range above the type point, which is to say in the range of full modulation of the inverter,

at the particular motor speeds in the lower range of the associated drive moment that is to be produced or the braking moment that is to be delivered, the associated intermediate circuit voltage does not have to be raised to the increased value as predetermined by the prior art. According to the present invention, the intermediate circuit voltage can be represented by an improved characteristic mapping in the form

$U_d = F(M, n)$ . According to this, if the demand for torque is low, the intermediate circuit voltage can be kept constant, or raised by a few percentage points relative to the intermediate voltage that prevails below the type point, which is to say in the pulse range of the inverter. Only in the face of increased demands for torque that are above the type point does the intermediate circuit voltage have to be increased to the value determined by the prior art as a function of the increased demand for torque in order to satisfy the demands imposed on the drive system with respect to torque and motor speed. The power loss of the drive system is then always minimal. The operating range in which the components in the intermediated circuit voltage changer are acted upon by a reduced voltage, and thereby have a longer service life with reduced power loss, is thereby extended beyond the type point for motor speed.

In addition to, or independently of this, control of the magnetic flux in the particular drive motor can be effected in a similar way. Accordingly, at motor speeds above the type point to higher speeds, the magnetic flux in the drive motor is constantly reduced, the initial value corresponding to the largely constant value as cited in the mapping beneath the type point. In this case, the magnetic flux-related in each instance to the selectable motor speed-is kept largely constant in the lower range of the torque that is to be applied or braked, and in contrast to this is only controlled so as to increase as greater torque is demanded. This results in a trough-shaped mapping that falls off to lower values above the type point, as is the case with respect to the mapping for the intermediate circuit voltage. Overall, the magnetic flux growth becomes continuously less towards higher motor speeds. As a result, above the type point and starting from lower torque demands in the lower range, the drive motor is operated with optimally low current values that are only increased if the torque requirements are increased to the current maximum value. In this case, magnetic flux reaches the value that is set by the prior art only at high torque requirements. As the magnetic flux decreases, electrical and eddy-current losses fall to a minimal value, the decrease of the magnetic flux at lower torque demands taking place only to the

point that it does not fall below the value of the pull-out torque of the drive motor.

If the drive system also comprises auxiliary components such as ventilating fans, pumps, etc. that are used to cool individual components such as transformers, d.c. voltage changers, and drive motors, it is expedient to include their power-consumption figures in the energy balance and to minimize them as a function of operating conditions. To this end, until such time as a component or a part thereof in the drive system reaches a predetermined, maximally permissible temperature, the cooling power and the supply power can be set to any value that is below maximal cooling power. In contrast to this, above a certain temperature, the cooling power is increased to the maximal value.

Control of the auxiliaries and thus the cooling of the individual components depends on the particular component temperatures and the number of cooling components that can be controlled independently of each other. If cooling components cannot be controlled independently, control is effected by selecting the maximal value.

In addition, or as an alternative, it can be expedient to control the cooling power in proportion to the power dissipation that occurs at a particular time in components with small thermal time

constants. This avoids partial overheating of components or parts thereof at locations that cannot be reached, or reached only with difficulty, with thermal sensors. Thus, there is intensive ventilation if load shocks occur in the drive system.

The energy balance can be further optimized if--beneath a predetermined maximal temperature and power-loss value in the drive system--the cooling power is only increased if the total energy that is to be used for cooling is smaller than the sum of the additional electrical power dissipation that occurs additionally in the drive system in the event of inadequate cooling. To this end, the power dissipation of the individual components is determined from current operating data and a comparison with, for example, empirically determined values, is used to establish whether it is more favourable in comparison to the currently required cooling power and with respect to the overall energy balance to switch on the auxiliaries immediately or at a later time if temperatures are rising or components of the drive system are under stress and becoming hot.

In addition, in order to improve the energy balance, it is also proposed that the magnetic flux in the drive motor be de-energized if there is no demand for torque, which is to say when a rail vehicle is coasting or at a standstill. This also

eliminates the energy requirement for no-load operation. In addition, by matching cooling conditions the auxiliaries power is also reduced by the diminished load demand. This takes place to the point that individual auxiliaries are completely switched off.

A rail vehicle that is operated in accordance with the measures according to the present invention, and equipped with the devices required for this purpose, has a minimal-loss drive system that can include the auxiliary systems.

The present invention will be described in greater detail below on the basis of the principles described on the basis of the drawings appended hereto. These drawings show the following:

Figure 1: A diagram showing the principles of a drive system with optimized control;

Figure 2: A flow diagram showing the steps to optimize the drive system;

Figure 3: A three-dimensional drawing showing the course of an intermediate circuit voltage in the indirect converter of the drive system;

Figure 3a: A diagram corresponding to Figure 3 for the prior art;

Figure 4: A three-dimensional drawing showing the course of the magnetic flux as a function of the torque and speed of a drive motor in the drive system;

Figure 4a: A drawing corresponding to Figure 4 for the prior art.

Figure 1 shows a control system for the variable-speed operation of a high-power drive system that includes an indirect converter 1 that, in the present invention, is supplied with power from a single-phase AC supply network 4 through a transformer 2 and a current collector 3. The primary winding is connected to the ground pole of the supply network 4 by way of at least one wheel 5 and at least one rail 6. The secondary winding of the transformer 2 supplies power to the intermediate circuit of the converter 1, the three-phase output of which supplies power to at least one three-phase motor 7 that serves as the driving motor for a rail vehicle. The drive motor 7 transfers driving torque either directly or through gearing to the other or additional driving wheels of the rail vehicle. Auxiliaries 9 are associated with the indirect converter 1, the transformer 2, and the drive motor 7; these include ventilating fans and/or liquid pump systems for cooling the components of the drive system that comprises drive motor 7, indirect converter 1, and transformer 2, and can optionally include the associated control systems, and

cool the components as required. In addition, there is also an optimization control system 10 for the overall drive system, and this collects the operating data for the components of the drive system, including the auxiliaries, and delivers optimizing control data to these components according to an optimization analysis, this being done in such a way that the total energy is optimized as a function of the operating point of the drive system and, in particular here, relative to the driving torque delivered by the drive motor and the motor speed and supply-network voltage prevailing at that time. A rail vehicle that is equipped in this way then operates with a minimal expenditure of energy.

The indirect converter 1 can be supplied with power from a diesel-electric generating system or from a d.c. network.

In the present invention, the indirect converter 1 includes a line-current converter 11 that is configured as a d.c. regulator when supplied from a d.c. source and, in particular in the case of a.c. operation, as a four-quadrant regulator, so as to permit the electrical energy that is generated when the motor is switched to the braking mode to be returned to the supply network. The line-current converter that is supplied from the secondary winding of the transformer supplies power from its

secondary side to an intermediate circuit 12 that comprises an electrical intermediate circuit capacitor 14 and an absorption circuit 15 that is connected in parallel thereto. A pulse inverter 16 is connected to the intermediate circuit 12 that is supplied with direct current, and this generates a variable frequency three-phase current for supplying the variable-speed drive motor 7 with the required driving energy and has a modulation that ranges from zero to full modulation. The inverter modulation is characterized by the ratio of maximally possible to actual inverter output voltage, the maximally possible output voltage being achieved at full modulation. At full modulation, the inverter functions in block mode, and in the remaining modulation range the inverter functions in pulse mode.

The line rectifier 11 is so controlled by the optimization control system 10 that there is optimal intermediate circuit voltage (Figure 3) that is matched to the operating conditions of the drive motor 7 in the intermediate circuit 12. The variability of the intermediate circuit voltage is indicated by an arrow that points obliquely upwards (Figure 1). The pulse inverter 16 is, in its turn, similarly controlled from the optimization control system 10, once again as a function of the operating requirements on the drive motor and the value of the intermediate circuit voltage, in that the magnetic flux in the

drive motor 7 is optimally matched to the current operating conditions with respect to the torque that is required and the speed of the motor by changing the three-phase voltage. The supply voltage of the drive motor 7 is thus similarly variable, and is symbolized by an arrow that points obliquely upwards (Figure 1).

In order to minimize the total energy requirement of the drive system, including the auxiliaries, Figure 2 shows that a minimal intermediate circuit voltage  $U_{zwk \min}$  is determined for the corresponding operating point from the current line voltage from the input values required (torque  $M$  and required motor speed  $n$ ), a maximal permissible intermediate voltage  $U_{zwk \max}$  being determined for this operating point at the same time. The minimal intermediate circuit voltage must be smaller than or equal to the maximal intermediate circuit voltage that has been determined. Based on the predetermined minimal intermediate circuit voltage in the intermediate circuit 12 that is to be generated by the line rectifier 11, a loss calculation is completed in the optimization control system 10; this takes into account all the components of the drive system with respect to their electrical losses that are to be expected at the operating point with the pulse inverter operating in pulse mode, the

intermediate circuit voltage being held at a minimal value with the pulse inverter operating in pulse mode. The control data obtained thereby are stored in an results matrix. Based on this, the intermediate circuit voltage that provides for the minimal overall losses in the drive system is set in the intermediate circuit 12. The results for the individual levels are again stored in the results matrix by level. If the voltage in the intermediate circuit 12 reaches its minimal-value range, the value for which an optimal energy balance results is read out from the results matrix by comparison of the control data stored for the individual levels. Computation of the energy balance is completed for every possible working point of the drive motor 7.

The intermediate circuit voltage is held at a lowest value until such time as the motor voltage needed to produce the necessary torque in the drive motor calls for a higher value of the intermediate circuit voltage. In Figure 3, this area of the curve is shown approximately as planes. The result of the optimization calculations for the intermediate-circuit voltage is shown in Figure 3, the motor speed predetermined by the type point  $t_p$  being at a value where there is a significant change in the mapping. In the three-dimensional coordinate system that is shown, the x axis shows the torque of the drive motor for driving and braking mode, and so the zero point is located at the midpoint of the relevant range of the x axis. The intermediate

circuit voltage is recorded on the y axis, which is vertical, whereas the z axis shows the motor speed. According to this, at motor speeds above the motor speed predetermined by the type point up to the maximal motor speed and in the lower range of the torque that is to be developed or retarded by the drive motor 7, the intermediate circuit voltage in the intermediate circuit 12 can be kept largely at the value that it has beneath the predetermined motor speed, which is to say the type point. As the motor speed increases, torque decreases, to the point that the intermediate circuit voltage can to a large extent remain at the level that prevails in the pulse range of the inverter. Only when the torque requirement that is related to motor speed exceeds this is the intermediate circuit voltage increased as a function of torque. This results in a trough-shaped mapping for the driving and the braking modes.

Compared to Figure 3, Figure 3a shows the family of curves and the intermediate circuit voltage as in the prior art. This shows that the intermediate circuit voltage is increased from the speed that corresponds to the type point independently of the torque that is to be delivered by the drive motor in each instance up to its maximal value. In contrast to this, according to the present invention, the intermediate circuit voltage is first increased in

the area of the upper torque requirement; thus, it is dependent on the torque.

After optimization of the intermediate circuit voltage as in Figure 2, according to Figure 2, under the conditions determined by the torque and motor-speed requirements, the optimal magnetic flux required for the required power output of the drive motor 7 is determined. When this is done, the point of departure is that the immediate intermediate circuit voltage is not equal to the optimal intermediate circuit voltage and the relative magnetic flux is less than 1, and can thus be below the maximal magnetic flux. Starting from the maximal flux, in a computer model the flux is reduced incrementally to a preestablished value. When this is done, the losses in the inverter and the drive motor are determined and stored in a mapping as a function of the flux. The flux that is associated with the minimum loss is read out as optimal flux and passed to the drive system as a reference variable. This is done for every working point of the drive system. Given optimization of the intermediate circuit voltage in the same way as the magnetic flux, the power losses generated by the components that have to be considered and the associated parameters from the optimization control system 10 are included in the optimization process. In this connection, in order to minimize the losses in the drive system, it is possible to

complete only the optimization of the intermediate circuit voltage or only the optimization of the magnetic flux for the drive motor, if only one of these measures is meaningful in the technical sense or is to be effected for reasons of cost.

Figure 4 shows the mapping for the optimized control of the magnetic flux in the drive motor, once again in three dimensions.

In this figure, the x axis shows the motor speed, the y axis shows the normalized magnetic flux, and the z axis shows the required driving or braking moment of the drive motor  $T$ . The zero point for the torque is recorded at the mid-point of the z axis, positive torque moments standing for drive energy, and negative torque moments standing for braking energy.

Accordingly, energy optimized operation will result at full modulation of the inverter, if there is a sharper reduction of the magnetic flux towards the maximum motor speed in the lower area of the torque requirement than in the upper area of the torque requirement. Thus, when the inverter is operating in pulse mode at a small torque requirement--depending on the working point--there will be minimal power loss caused by a reduction of the magnetic flux. When the inverter is at full modulation, which is to say in block operation, it is no longer possible for the inverter to affect the flux. Here, the flux results from the intermediate circuit voltage, which has already

been optimized as a function of the working point. Optimizing the magnetic flux also reduces the losses generated in the stator winding, like those in the iron, in the drive motor 7.

Figure 4a shows the mapping for the magnetic flux as it is realized by devices as in the prior art. According to this, here the magnetic flux is only controlled as a function of the speed of the drive motor, independently of the torque that is required.

In contrast to this, with the optimized method as in Figure 4, reduction of the magnetic flux in a major part of the lower torque mapping and a reduction of power loss is achieved by reducing the magnetic flux in the lower load range of the drive motor.

The auxiliaries that are associated with the drive system in order to dissipate the power loss that occurs in the components is so controlled that the cooling power of at least one component that has a high thermal time constant, or a part thereof, is held at a greatly reduced value that is well below the maximal cooling power until a predetermined temperature is reached. A component with a high time constant is, for example, the oil-cooled transformer or the drive motor that contains iron, as well as any other individual component that is of great mass. Only above a predetermined temperature, depending on the current temperature,

of at least one of these components, or a part thereof, the cooling power is increased to its maximum value, this being done as a function of the temperature. In addition, the cooling power can be controlled in proportion to the power loss that occurs in the drive system, in components with a low thermal time constant.

Components with low thermal time constants are, for example, the windings of the drive motor, components in the power converter, braking resistors, and the like. When considering energy overall, it is expedient that below predetermined maximal temperature and power loss values in the drive system, the cooling power is only increased if the additional energy that has to be expended additionally for cooling is smaller than the sum of the electrical energy loss that occurs in the drive system if no cooling takes place. If, for example, a liquid cooling system is associated with individual components of the drive system such as the oil transformer, and if a ventilation system is associated with the drive motor and optionally with other components, it is expedient to control the cooling power of these individual auxiliaries selectively, as a function of the temperature and/or the load on the associated components, and thereby complete the optimization calculations, and the control resulting therefrom, on an individual basis.

With respect to the energy balance, it is advantageous if the magnetic flux in the drive motor be de-energized if there is no requirement for torque, which is to say that the magnetic flux or the feed voltage for the drive motor 7 be adjusted to zero. In the case of a rail vehicle that is rolling or stationary, no energy is needed if the drive motor is operating in idling mode.

In addition, cooling and power for the auxiliaries is matched to the reduced load demands, up to the point that individual cooling systems and the auxiliary inverters used for supplying voltage to them can be switched off.

## Patent Claims

1. Method for controlling a high-performance, variable-speed drive system that comprises at least one drive motor and is designed for constant power consumption above a predetermined motor speed, and which is supplied with a variable intermediate circuit voltage through an indirect converter, said indirect converter being supplied with power from a power-supply network, the intermediate voltage being reduced relative to its maximal value in the motor-speed range above the predetermined motor speed, such that the intermediate circuit voltage is not reduced below a minimal voltage that is determined by the supply network voltage during operation, and in the motor-speed range beneath the predetermined motor speed, proceeding from the reduced intermediate circuit voltage, there is a transition to maximal intermediate circuit voltage as a function of motor speed at maximal motor speed, in particular for rail vehicles that are supplied with driving energy from an electrical current collector or from the vehicle's dedicated diesel-electric generator, characterized in that in the drive system, at motor speeds above the predetermined speed and up to the maximum speed, and in the lower range of the torque that is to be produced or retarded by the drive motor, the intermediate circuit voltage is held, at least largely, to the low value that it has below the predetermined motor speed.
2. Method as defined in Claim 1, characterized in that the intermediate circuit voltage is so adjusted at each working point that the minimal overall power loss is set up.

3. Method as defined in Claim 1 or Claim 2, characterized in that in the event that the field weakens, the magnetic flux in the drive motor is constantly reduced at higher motor speeds, and results from Uzwk, the magnetic flux being largely reduced in pulse mode of the current inverter as a function of the torque that the drive motor has to produce or brake; and in that the minimum will result for the sum of the power losses in the current inverter and the drive motor.
4. Method as defined in at least one of the Claims 1 to 3, characterized in that the drive system is cooled with the help of auxiliaries such as pumps and ventilating fans, whereby until a component that has a high thermal constant or a part thereof in the drive system reaches a predetermined temperature the cooling power is set to a greatly reduced value that is far below the maximal cooling power, and above a predetermined temperature at least one component or a part thereof is moved up to the maximum cooling power as a function of the current temperature.
5. Method as defined in at least one of the Claims 1 to 4, characterized in that the cooling power is controlled proportionally to the actual power loss in components with low thermal time constants in the drive system.
6. Method as defined in Claim 4 or Claim 5, characterized in that below a predetermined, maximal temperature and power loss value in the drive system, the cooling power is only

increased if the total energy that is to be expended additionally for cooling is smaller than the sum of the electrical energy lost in the drive system if no cooling takes place.

7. Method as defined in at least one of the Claims 4 to 6, characterized in that dedicated auxiliaries are associated with the individual components of the drive system; and in that the cooling power of these cooling operations is controlled selectively as a function of the temperature of and/or the load on the associated components.
8. Method as defined in at least one of the Claims 1 to 6, characterized in that the magnetic flux in the drive motor is de-energized if there is no demand for torque, and the line rectifier and the inverter are switched off.
9. Method as defined in Claim 8, characterized in that the auxiliaries that are available for cooling are matched to the changed load demands to the point that they are completely switched off.
10. Control system for controlling a high-performance, variable-speed drive system that comprises at least one drive motor and is designed for constant power consumption above a predetermined motor speed, and which is supplied with a variable intermediate circuit voltage through an indirect converter, the intermediate circuit voltage being reduced relative to its maximal value in the motor-speed range below the predetermined motor speed such that the intermediate circuit voltage is not reduced below a specific minimal

voltage that is determined by the main power supply voltage (contact wire), and in the motor-speed range above the predetermined motor speed, proceeding from the reduced intermediate circuit voltage, there is a transition to the maximal intermediate circuit voltage at maximal motor speed, said transition being dependent on the motor speed, in particular for rail vehicles, characterized in that in the drive system (1, 2, 7), the intermediate circuit voltage at drive-motor speeds in block operation of the inverter and in the lower range of the torque that is to be generated or braked by the drive motor (7) is, largely at least, to a value that corresponds to the intermediate circuit voltage in the intermediate circuit (12) below the predetermined speed of the drive motor (7), and is so adjusted that there is a minimal loss of power for the overall drive system, at every working point.

**Fetherstonhaugh & Co.**  
Ottawa, Canada  
Patent Agents

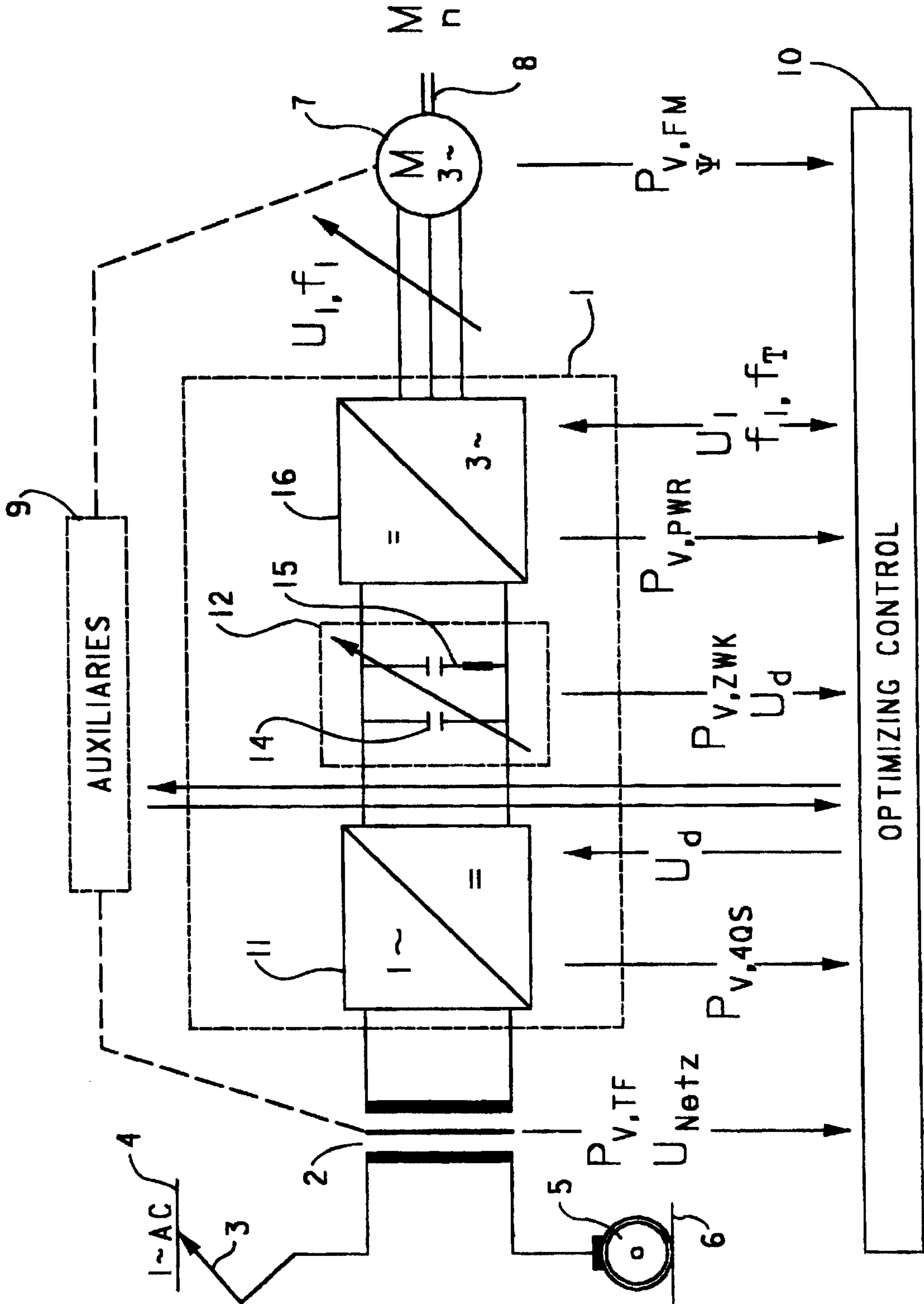

FIG. 1

2/5

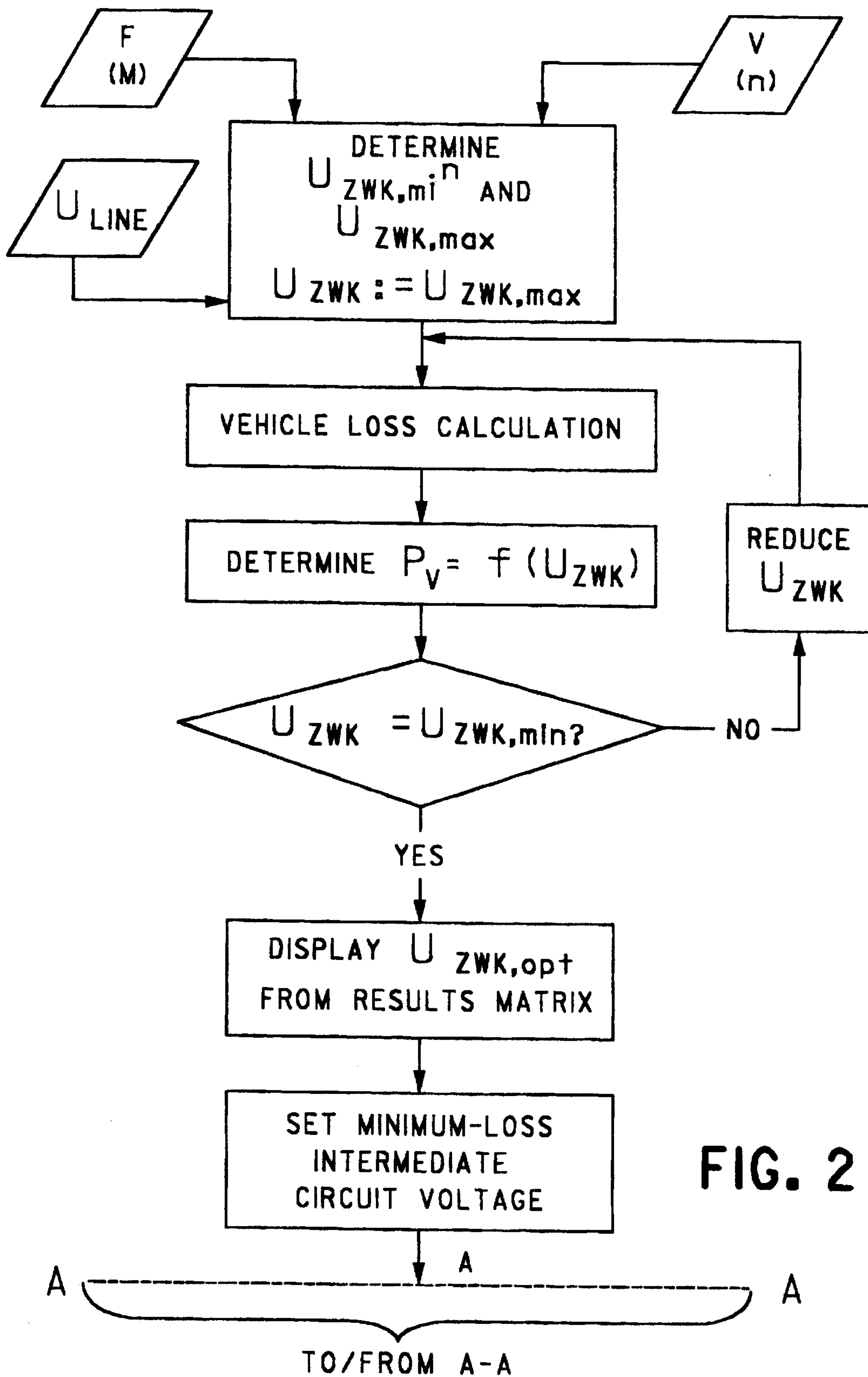

FIG. 2

3/5

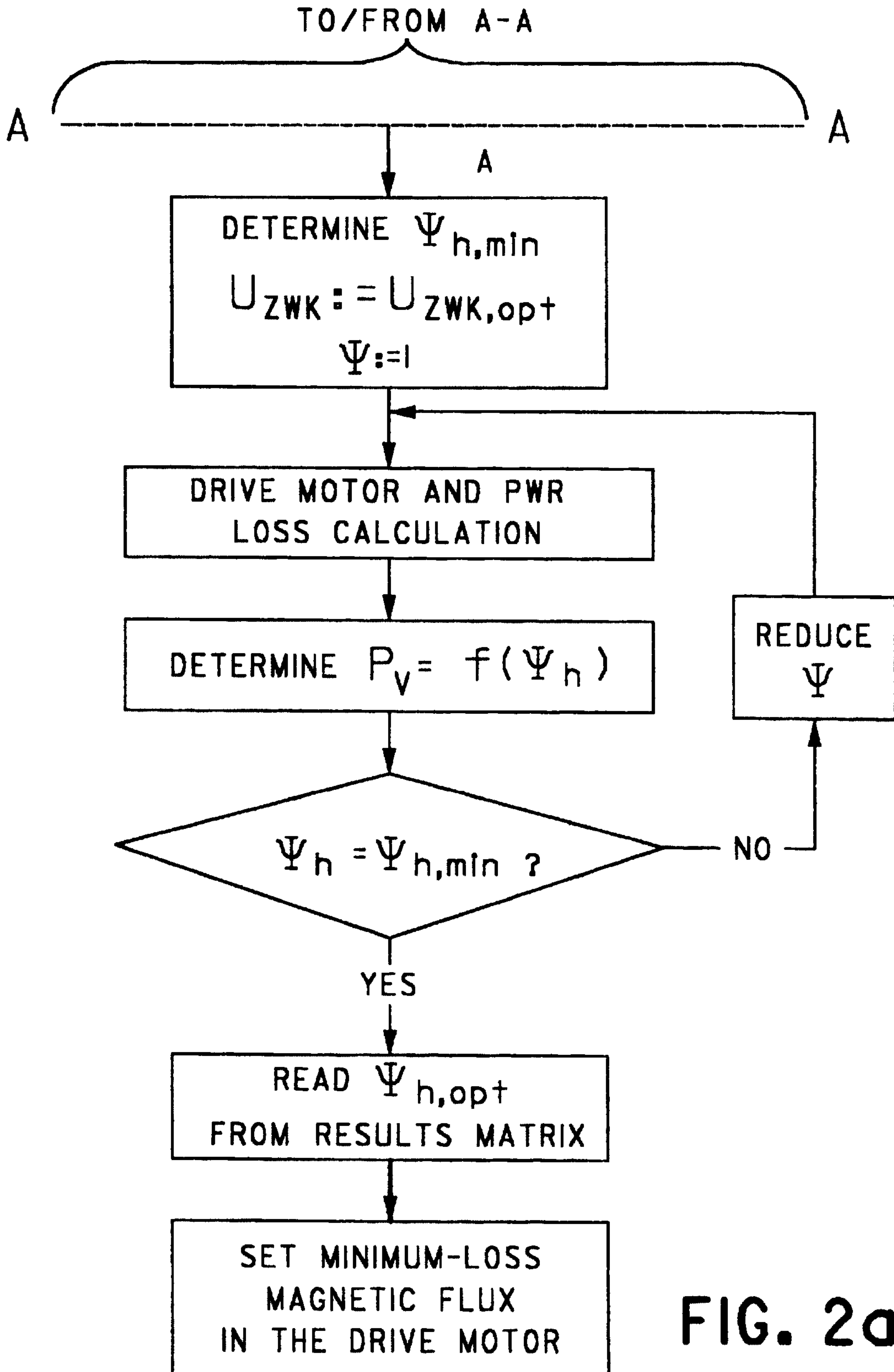
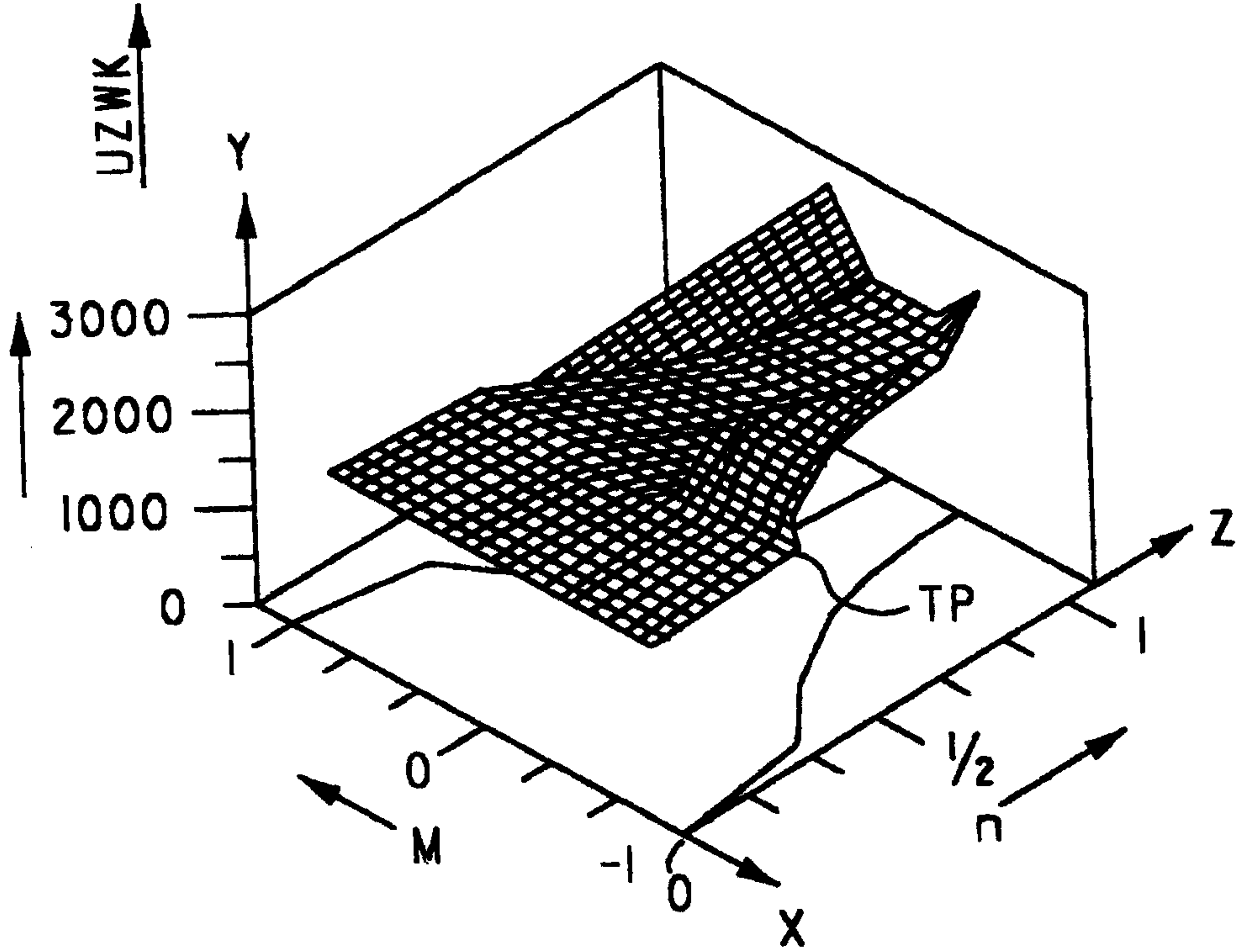
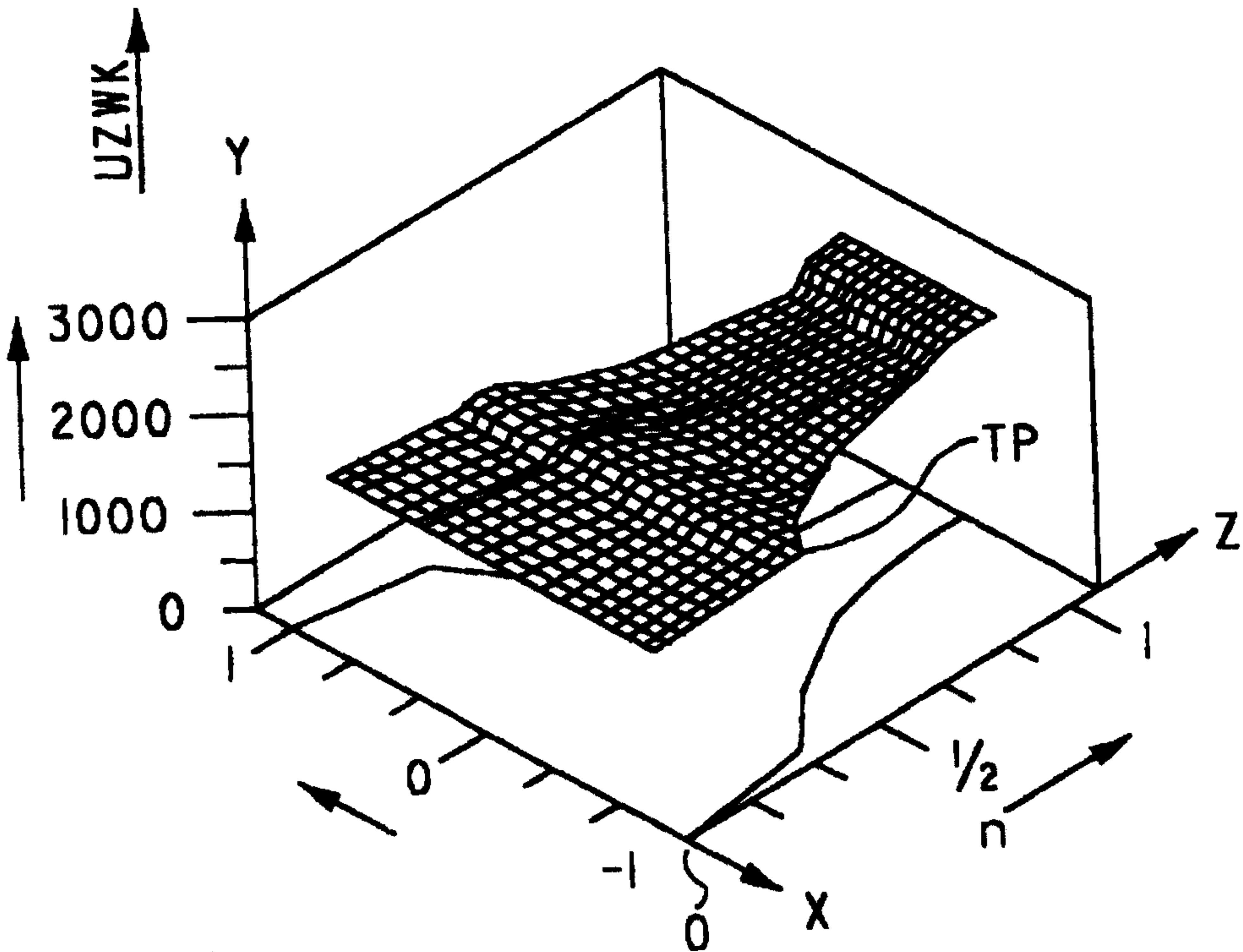

FIG. 2a

4/5

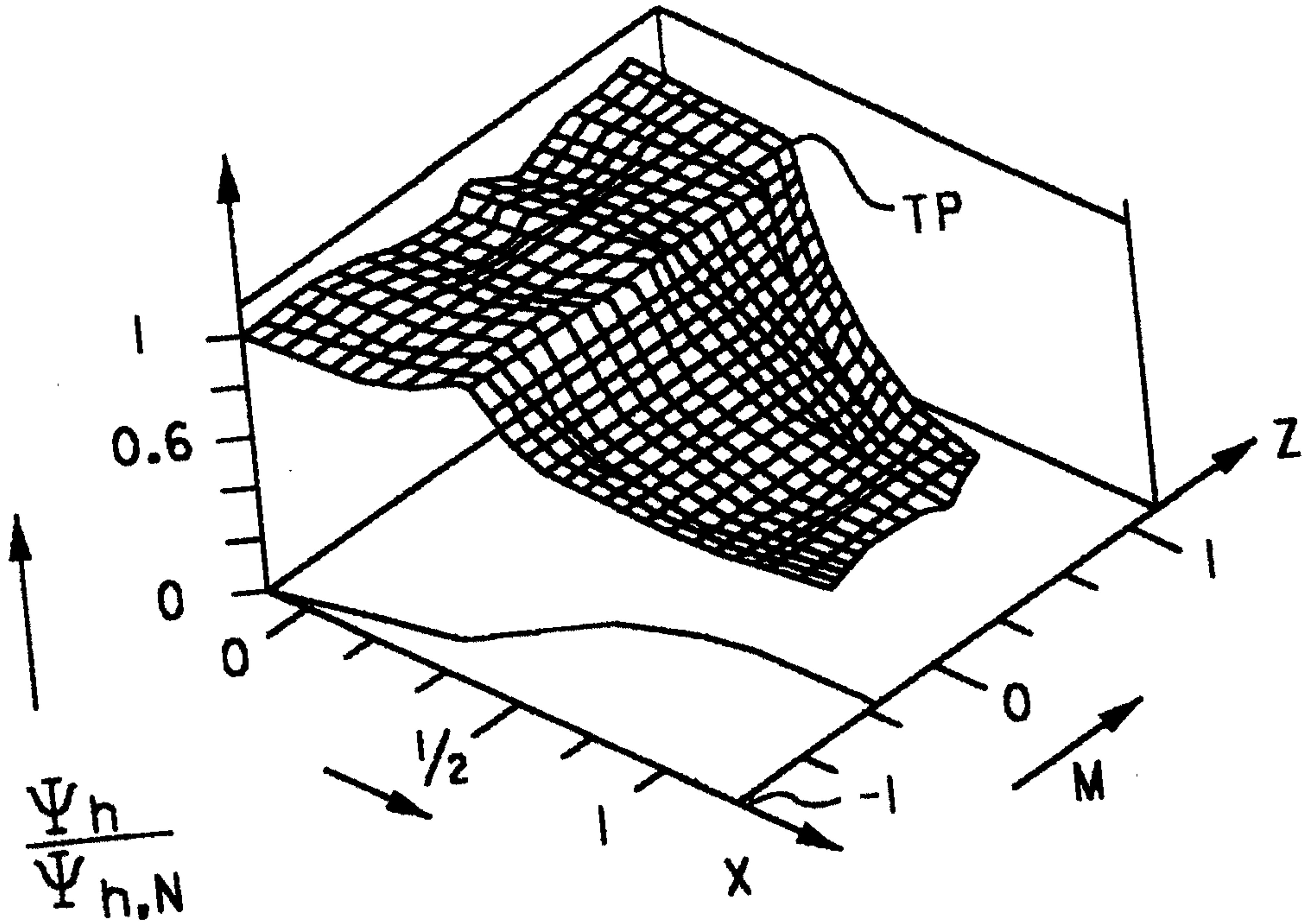

**FIG. 3**

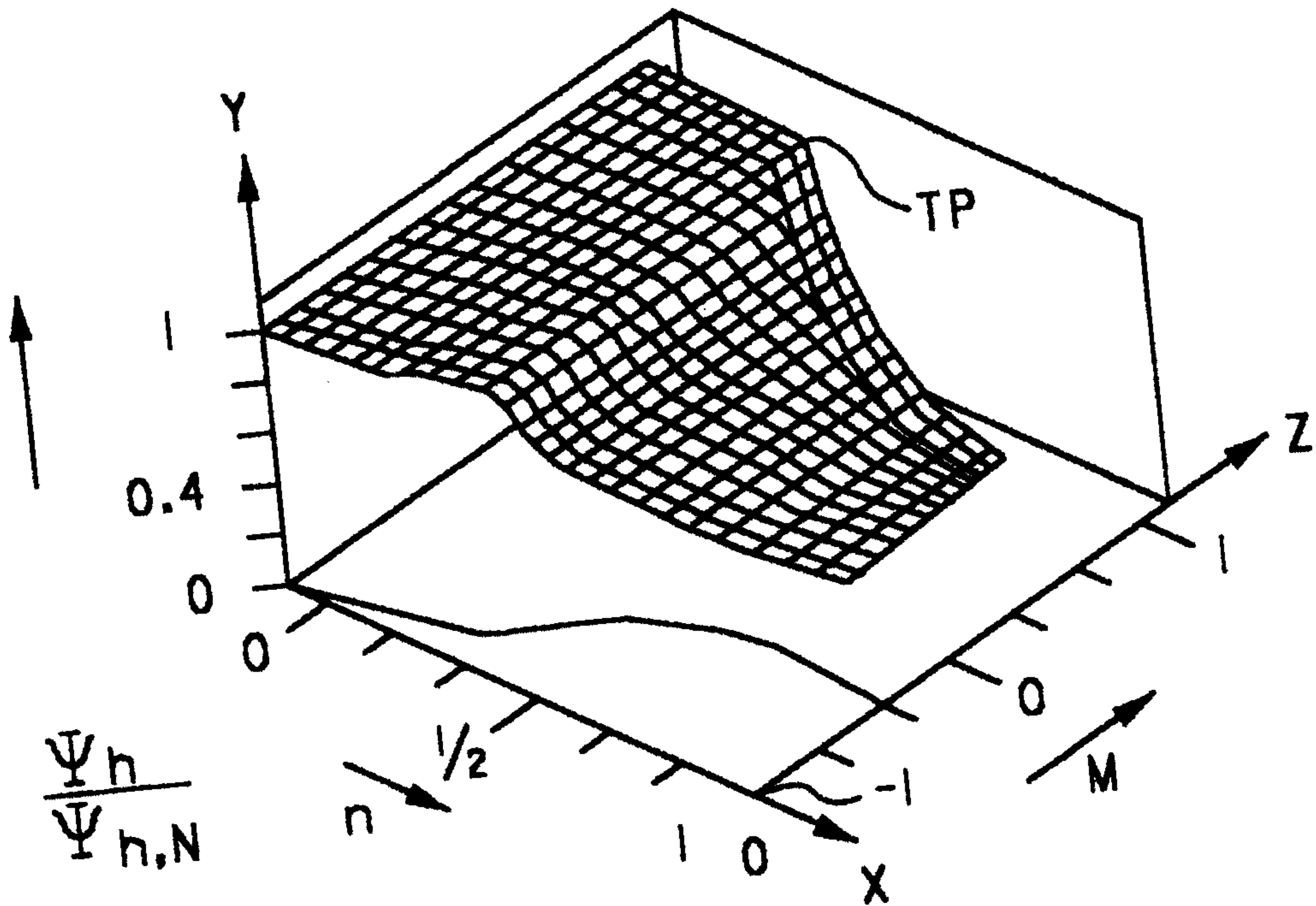

**FIG. 3a**  
(PRIOR ART)

5/5



**FIG. 4**



**FIG. 4a**  
(PRIOR ART)

