

(No Model.)

L. R. FAUGHT.
BORING TOOL.

No. 302,831.

Patented July 29, 1884.

FIG. 1.

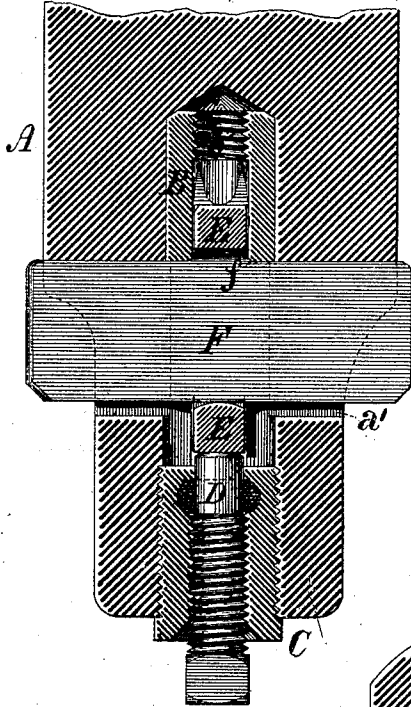

FIG. 2.

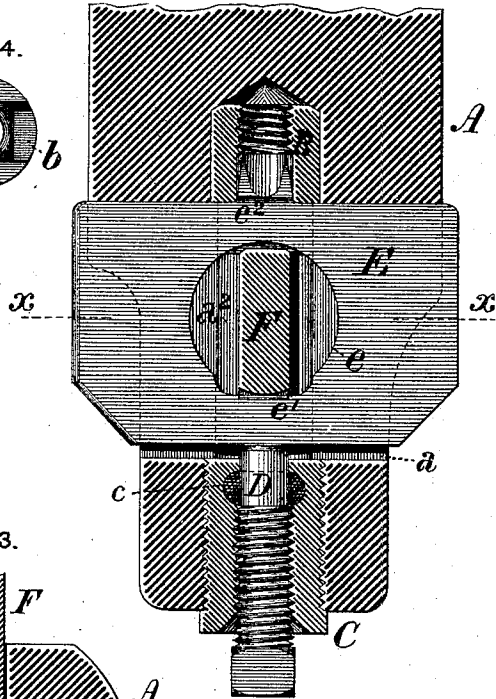

FIG. 4.

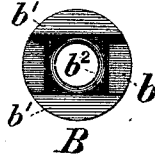

FIG. 3.

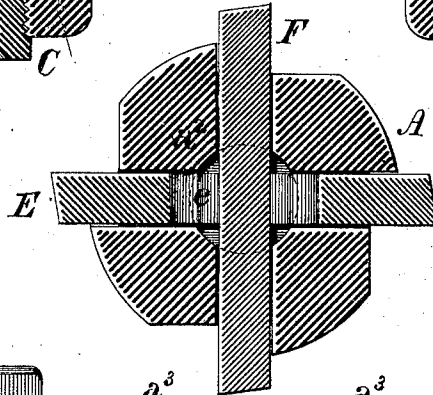

FIG. 5.

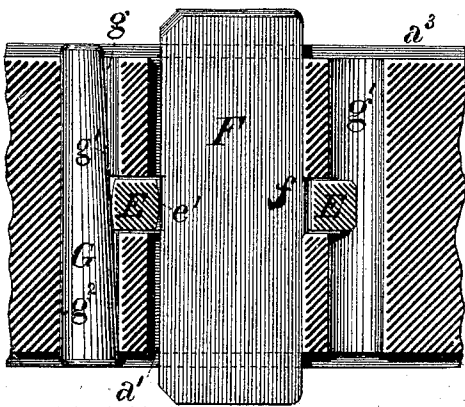
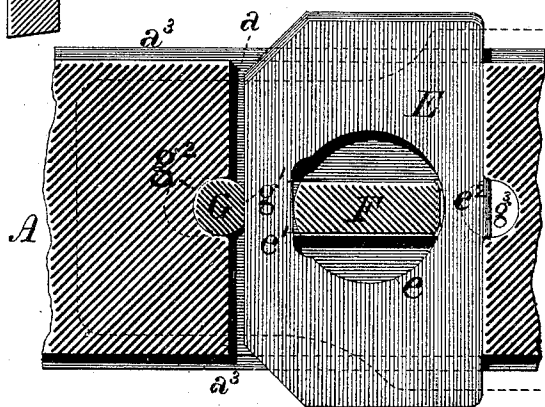

FIG. 6.



WITNESSES:

Geo. B. Sollier
Wm. E. Morgan

INVENTOR

L. R. Faught,
by J. Thomson Bell,
att'y.

UNITED STATES PATENT OFFICE.

LUTHER R. FAUGHT, OF PHILADELPHIA, PENNSYLVANIA.

BORING-TOOL.

SPECIFICATION forming part of Letters Patent No. 302,831, dated July 29, 1884.

Application filed December 29, 1883. (No model.)

To all whom it may concern:

Be it known that I, LUTHER R. FAUGHT, of the city and county of Philadelphia, in the State of Pennsylvania, have invented certain new and useful Improvements in Boring-Bars, of which improvements the following is a specification.

My invention relates to boring-bars of the class having two transverse slots at right angles one to the other, each adapted to receive a tool or cutter, instances of which are illustrated in Letters Patent of the United States Nos. 241,481, 253,523, and 289,522, granted and issued to me under dates of May 17, 1881, February 14, 1882, and December 4, 1883, respectively.

The object of my present invention is to enable a higher standard of strength and durability of the cutters to be attained; and, further, to provide effective and desirable means for securing the same in position, with the capacity of ready and convenient removal and replacement, as may be required.

The improvements claimed are hereinafter fully set forth.

In the accompanying drawings, Figures 1 and 2 are vertical longitudinal central sections at right angles one with the other, respectively, through the lower portion of a boring-bar embodying features of my invention; Fig. 3, a transverse section through the same at the line $x x$ of Fig. 2; Fig. 4, a bottom view of the shoulder-block detached; and Figs. 5 and 6, longitudinal central sections at right angles one with the other, respectively, showing a modification of the means for securing the cutters.

In the practice of my invention the boring-bar A is, similarly to those of my several Letters Patent aforesaid, provided with two transverse or diametric slots, a and a' , which, in the case of a vertical bar, or one projecting from a spindle, as in Figs. 1, 2, and 3, are located adjacent to its lower end, and in horizontal bars having supports at each end, as in Figs. 5 and 6, may be arranged in pairs at desired intervals in the length of the bar. The width of said slots is, as in the Letters Patent referred to, such as to admit easily the boring-tools or cutters, and their depth is greater than the depth thereof, so as to allow of the introduc-

tion, clamping, and removal of the same, as required. In lieu, however, of employing two cutters of equal depth and recessing or notching each of them centrally to bring their cutting-points as nearly as possible in the same plane, as in my prior constructions, I provide, under my present invention, a cutter having a central opening or passage which is closed at both its ends, and a shallower cutter having no recess or opening, and adapted to be passed through the opening of the cutter first named. In lieu, further, of forming end shoulders upon the cutters and supporting the same against peripheral dies in the bar, I construct the cutters with central bearing projections or shoulders abutting against a central bearing, either fixed or removable in the boring-bar, and secure both cutters in position by a single clamping screw or key, all as presently hereinafter to be described.

Referring to Figs. 1 to 4, inclusive, the transverse slots a and a' of the boring-bar A are suited, respectively, to receive a cutter, E, and a cutter, F, which is shallower than the cutter E to such a degree as to pass freely through a transverse opening or passage, e , formed therein. The passage e , which is closed completely at each end by the metal of the cutter, is preferably of substantially circular form, with a flattened throat, e' , at bottom, which bears against the lower side of the cutter F. In cutters of smaller size the width of the passage e may be reduced as desired, to maintain proper strength in correspondence with reduced length of the cutter, so that the passage shall be of rectangular or elliptical form, with strong curves or fillets at top and bottom. The cutters E and F have plain or straight faces at top, upon which are formed central bearing projections or shoulders, e'' and f , respectively, the bearings of which are formed in a shoulder-block, B, of hardened steel, inserted and fitted tightly in the upper end of a central opening, a'' , in the bar A. The block B has a transverse recess, b , on its lower side to receive the deeper cutter E, the shoulders e'' of which bear against the top of the recess, and the shoulders f of the cutter F bear against the lower ends of the jaws b' on each side of the recess, separate and independent bearing seats or faces being thus pro-

vided by the shoulder-block B for each of the cutters E and F. In order to enable the shoulder-block to be withdrawn from its position when required, a female thread, b^2 , is cut centrally within it from the recess b to its upper end, the clear opening of the recess being not less than the outer diameter of said thread, and by inserting a corresponding screw of sufficient length to bear against the top of the opening a^2 , in which the shoulder-block is fitted, the latter may, by the rotation of the screw, be readily backed out and withdrawn. The opening a^2 , which extends without reduction of diameter to the lower end of the boring-bar, is threaded at and adjacent to its lower end, to engage the external thread of a bushing, C, which is internally threaded to act as the nut of a central clamping-screw, D, by which the cutters are secured in working position in the bar. The cutter E being placed in its slot a , and the cutter F inserted in its slot a' and passed through the opening e of the cutter E, and each cutter being adjusted to project for equal distances from the bar on both sides of its axis, the clamping-screw D is screwed to a tight bearing against the lower side of the cutter E, thereby forcing the shoulders e^2 of said cutter against the bearings at the top of the recess b of the shoulder-block B. The tightening of the clamping-screw D causes the throat e' of the passage to bear coincidentally against the lower side of the cutter F, and to force the shoulders f thereof against their bearings on the lower ends of the jaws b' of the shoulder-block, the clamping-screw thus acting, by its direct thrust, to fix and hold both the cutters. The surface of the throat e' of the cutter E and the corresponding abutting surface of the cutter F are curved or segmental in central transverse section, as shown, so that a central pivotal bearing, through which accurate adjustment may be obtained, is afforded. An annular recess is formed in the upper portion of the bushing and is filled with suitable packing, c , which surrounds the upper unthreaded portion of the clamping-screw D and protects the threads thereof from the contact of borings or other foreign matter.

The construction shown in Figs. 5 and 6 is one which is specially adaptable to boring-bars supported at both ends, but which, as indicated by dotted lines in Fig. 6, is likewise applicable to a boring-bar which has no lower end support, as hereinabove described. The cutters E and F constitute one pair of a series located at desired distances apart in the length of the bar A, and fitting in transverse slots a a' , at right angles one to the other, each of said slots being in line and communicating with two of a series of four longitudinal grooves or recesses, a^3 , in the bar. In lieu of the shoulder-block removable bearings before described, fixed bearings are provided for the shoulders of the cutters in the metal of the bar, the shoulders or bearing projection e^2 of the cut-

ter E fitting against central bearings in a transverse opening, g , in the bar A, and the shoulders f of the cutter F fitting against similar bearings in one side of the slot a . The cutters are secured in position by a transverse key or wedge, G, which, in combination with the cutters E and F, performs the same function as and acts as the mechanical equivalent of the clamping-screw D, before described. The key G, which is not, *per se*, claimed herein as of my invention, will be set forth in another application for Letters Patent to be filed in due time by me.

It will be obvious that my improvements are equally applicable in connection with one or a pair of cutters, and that where two are used one may be readily removed and replaced without interfering with the operation of the other, which is left in position to be used singly, if so desired. The advantage in point of simplicity and economy of construction, by dispensing with the end shoulders and bearings, is a material one, and, in addition thereto, the shoulders are removed from an exposed outer position to a comparatively secure inner one. It will be seen, further, that the shoulders are unaffected in position by the stretching of the cutters that may from time to time be necessary to keep them up to standard size, and are exempt from their former liability to breakage in hardening or in use, and that the strength and durability of the cutters are promoted by the substitution of a single closed-ended passage for the two open recesses heretofore employed.

I claim as my invention and desire to secure by Letters Patent—

1. The combination, substantially as set forth, of a transversely-slotted boring-bar, a tool or cutter having formed through its body a central hole or passage suited to admit a cutter of less depth, and a clamping-screw.

2. The combination, substantially as set forth, of a transversely-slotted boring-bar, a tool or cutter having a central bearing projection and fitting in the slot of said bar, a bearing located centrally in said bar and abutting against the bearing projection of the cutter, and a clamping-screw bearing against the opposite face of said cutter.

3. The combination, substantially as set forth, of a boring-bar having two diametric slots at right angles one to the other, a tool or cutter having a central bearing projection on one of its sides, and having a hole through it, said cutter fitting in one of the diametric slots of said bar, a cutter having a central bearing projection on one of its sides, said cutter passing through and bearing against the opening of the cutter first specified and through the opposite slot of the bar, bearings located centrally in said bar and abutting against the bearing projections of the cutters, and a clamping-screw bearing against the face of the cutter first specified opposite its bearing projection.

4. The combination, substantially as set
forth, of a boring-bar having two diametric
slots at right angles one with the other, a
shoulder-block fixed in a central opening in
5 said bar, above the slots thereof, a pair of
tools or cutters fitting in the slots of the bar,
each of said cutters having a central bearing
projection on one of its sides abutting against
a seat or face on the shoulder-block, and one
10 of said cutters being passed through a central
opening or passage in the other cutter, and a
clamping screw or key bearing against the
cutter which is provided with said opening
or passage.

5. The combination, substantially as set 15
forth, of a boring-bar, a shoulder-block fitted
in said bar, having a transverse recess at its
lower end and a central threaded opening
extending from said recess to and through
its opposite end, a cutter fitting in the trans- 20
verse slot in the boring-bar and in the recess
of the shoulder-block, and a clamping-screw.

LUTHER R. FAUGHT.

Witnesses:

J. SNOWDEN BELL,
CHAS. E. PANCOAST.