



US 20050188902A1

(19) **United States**

(12) **Patent Application Publication**

Savoie

(10) **Pub. No.: US 2005/0188902 A1**

(43) **Pub. Date:**

Sep. 1, 2005

(54) **DISPLAY TABLE WITH ACCESSORY POLE**

Publication Classification

(76) **Inventor:** Troy S. Savoie, Burnsville, MN (US)

(51) **Int. Cl.⁷** A47B 9/00; A47B 3/00

(52) **U.S. Cl.** 108/107

Correspondence Address:

**PATTERSON, THUENTE, SKAAR &
CHRISTENSEN, P.A.
4800 IDS CENTER
80 SOUTH 8TH STREET
MINNEAPOLIS, MN 55402-2100 (US)**

(57) **ABSTRACT**

(21) **Appl. No.:** 11/068,209

(22) **Filed:** Feb. 28, 2005

Related U.S. Application Data

(63) Continuation-in-part of application No. 10/998,508, filed on Nov. 29, 2004.

(60) Provisional application No. 60/525,704, filed on Nov. 28, 2003.

A display table includes a tabletop, a shelf and a plurality of legs. The legs can be foldably attached to the bottom of the tabletop and are foldable between an extended and erected position and a folded and transport position. The table can include at least one accessory pole or mast for mounting a display device. In one embodiment, the at least one accessory pole includes an upper post member and a lower post member adapted for telescoping connectivity, as well as a plurality of peripheral channels for mounting the display device. Various mounting assemblies are employed for mounting a variety of display devices, such as monitors and signage.

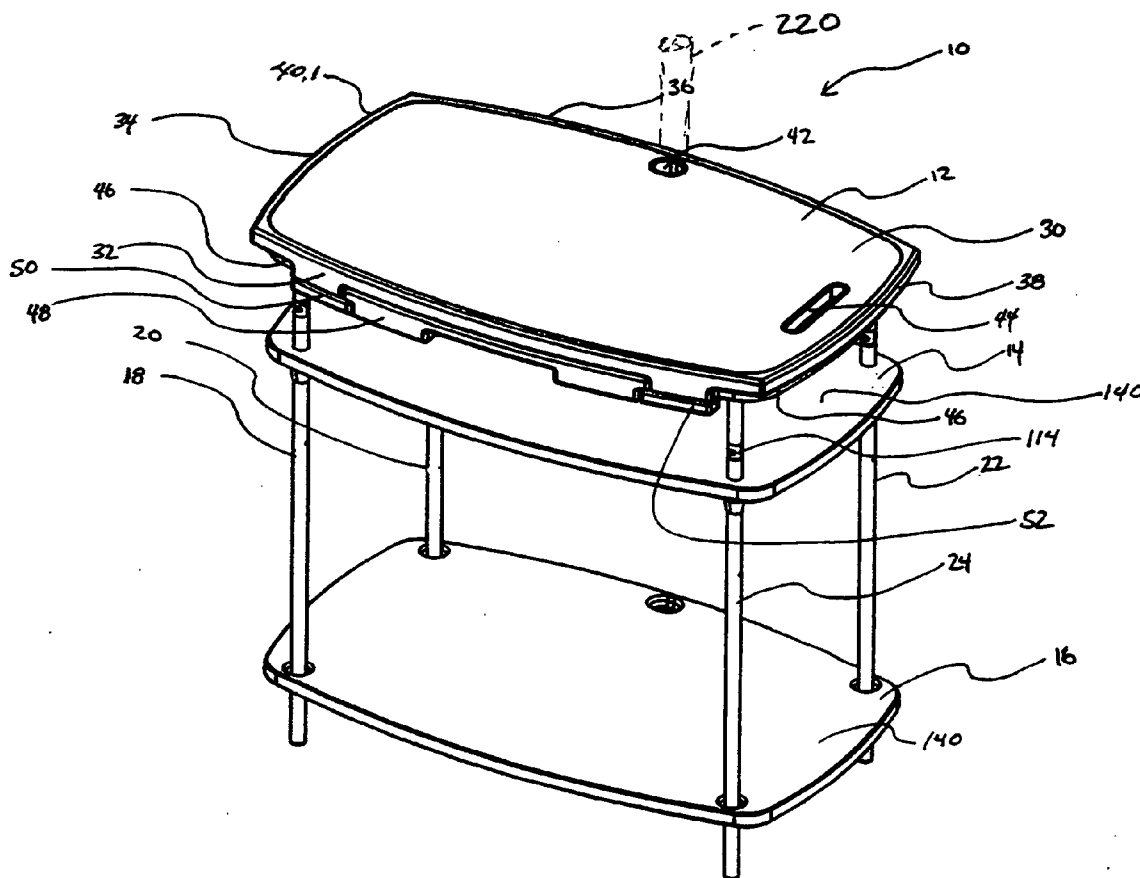

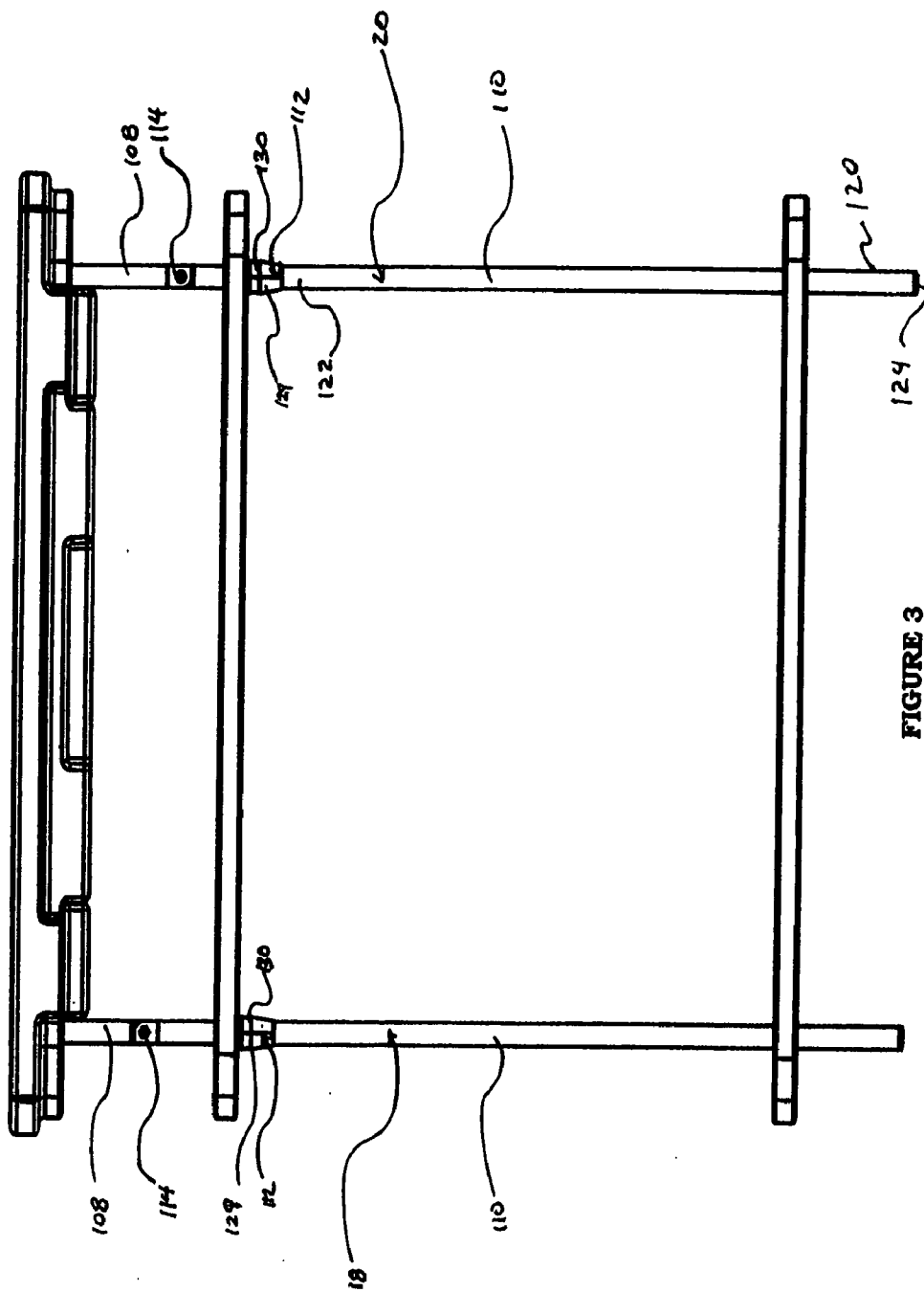

FIGURE 3

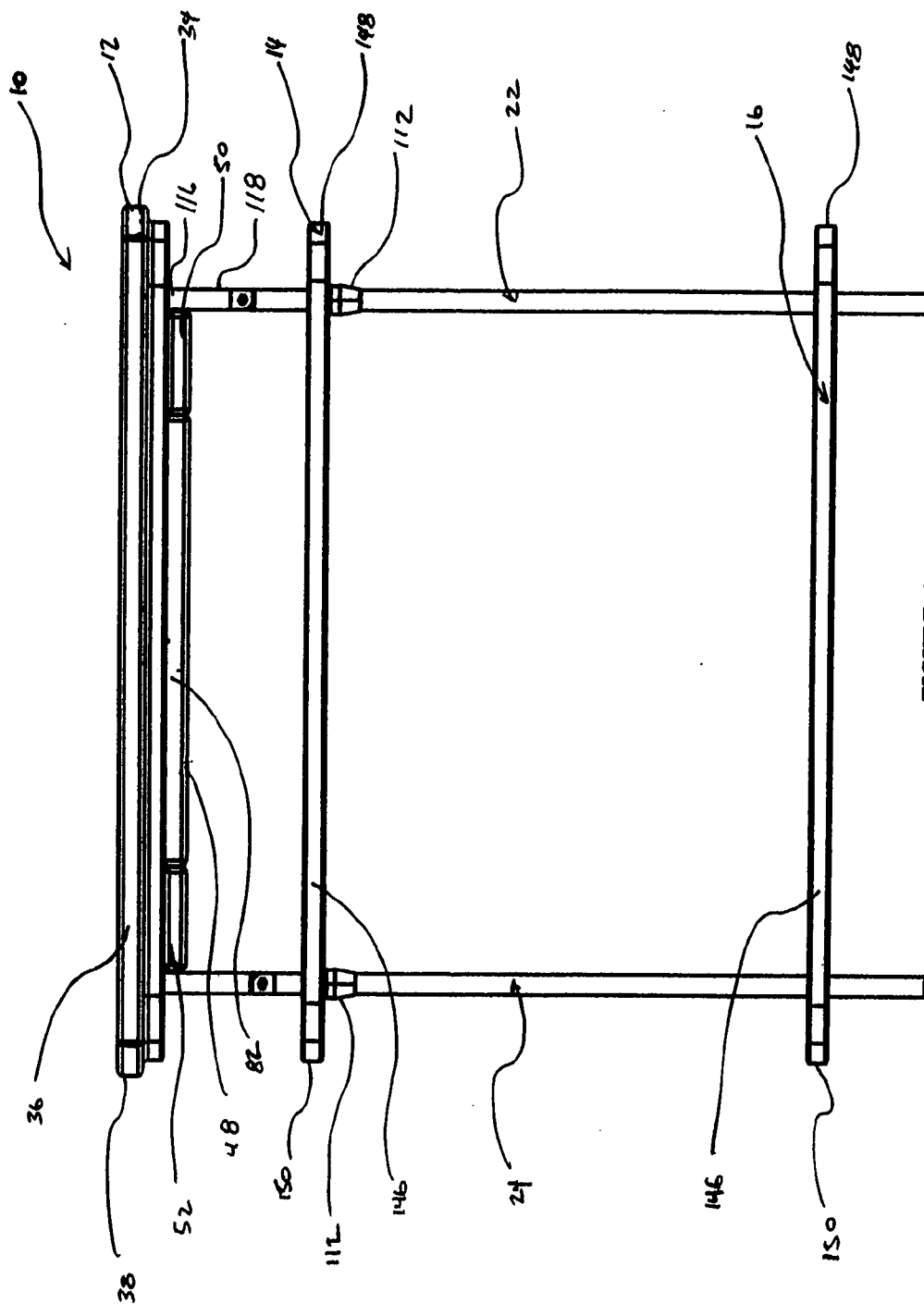

FIGURE 4a

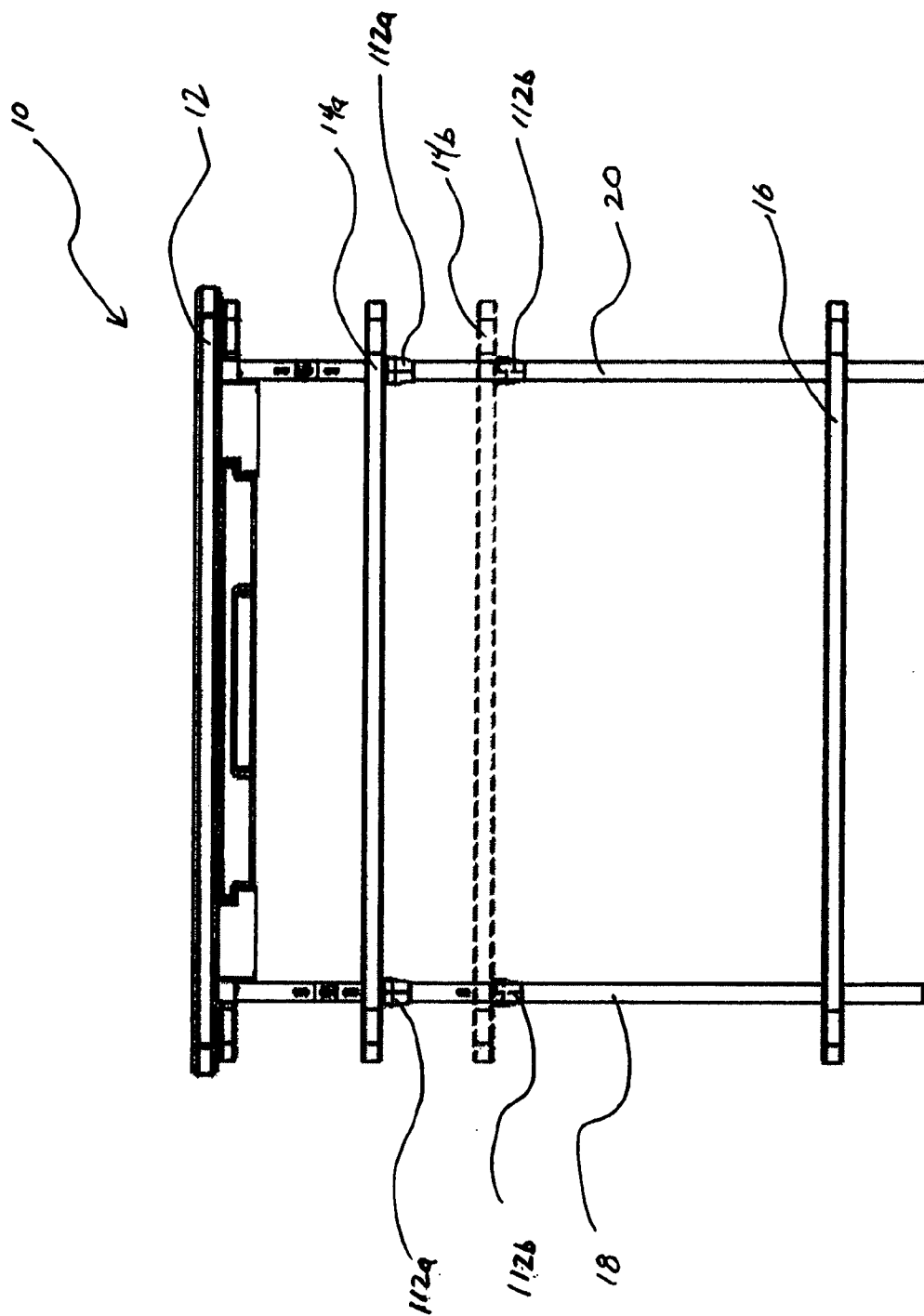

FIGURE 4b

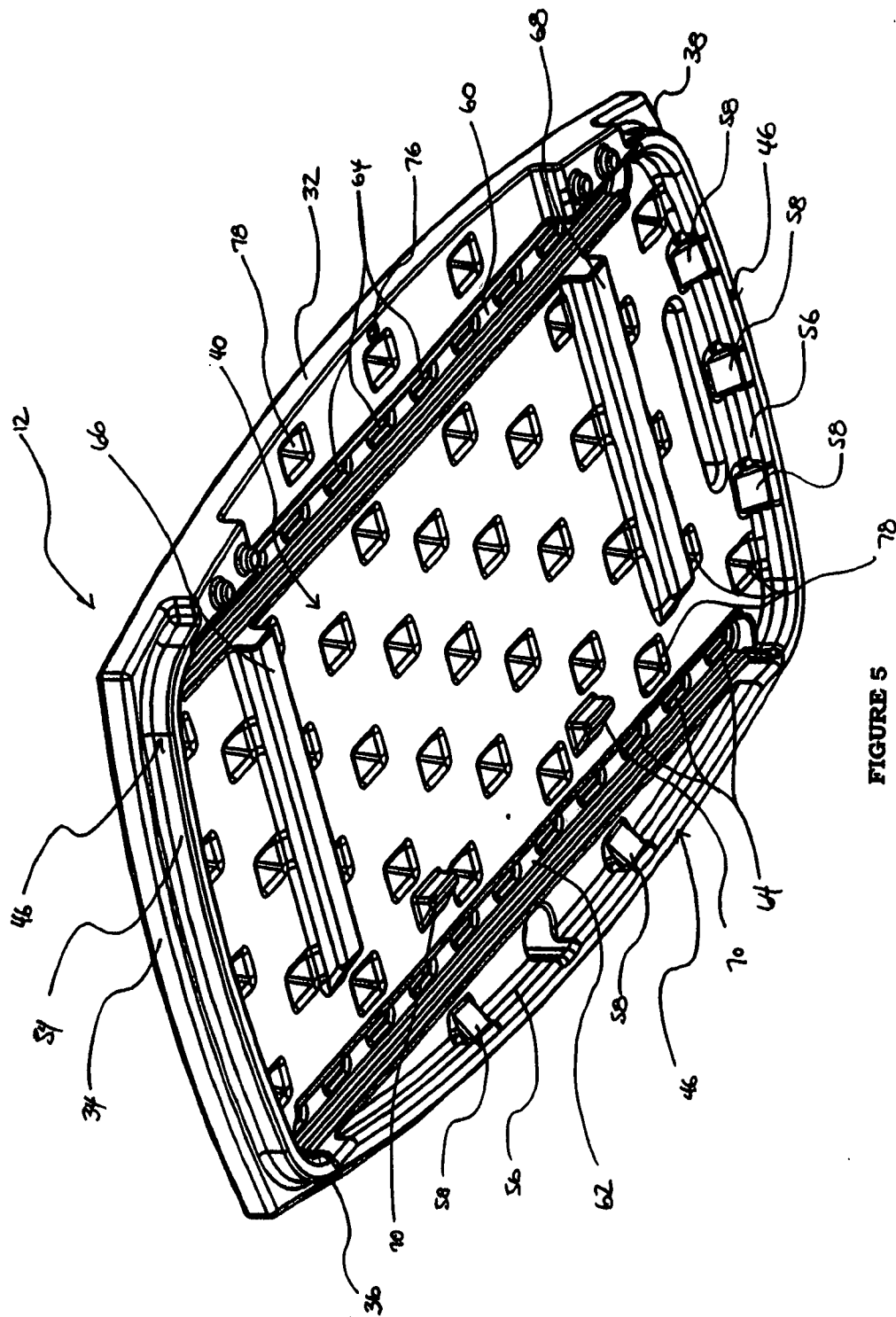

FIGURE 5

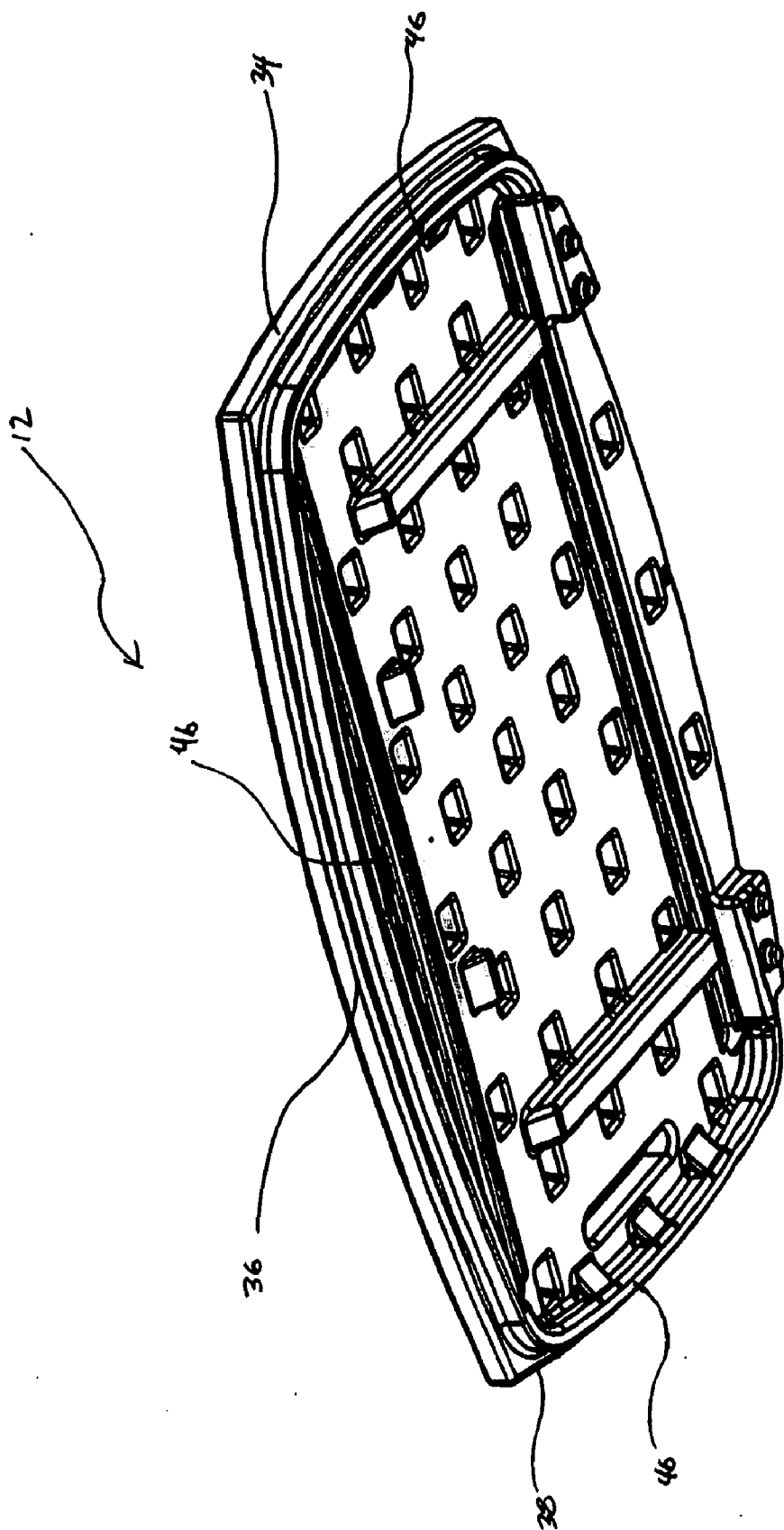

FIGURE 6

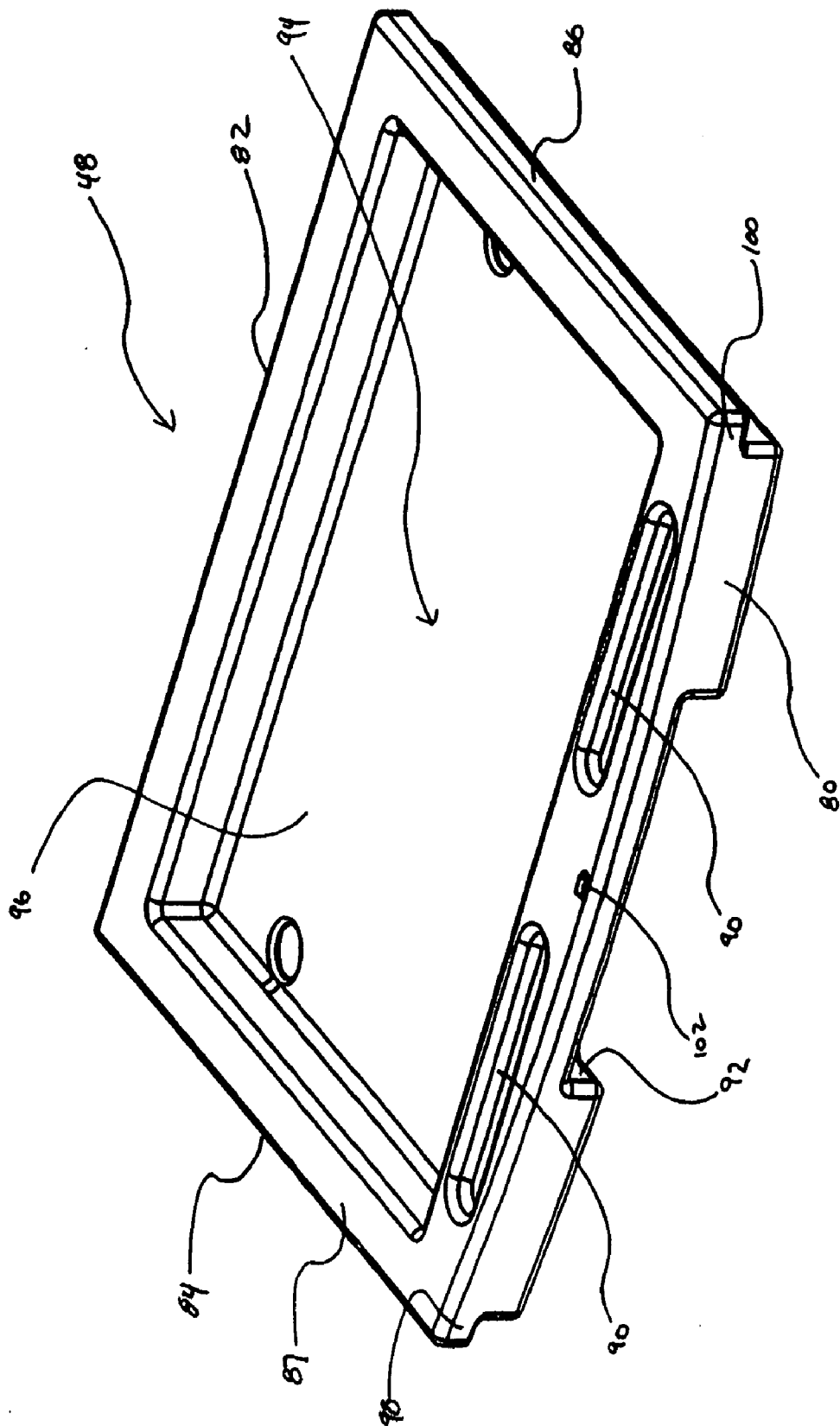

FIGURE 8

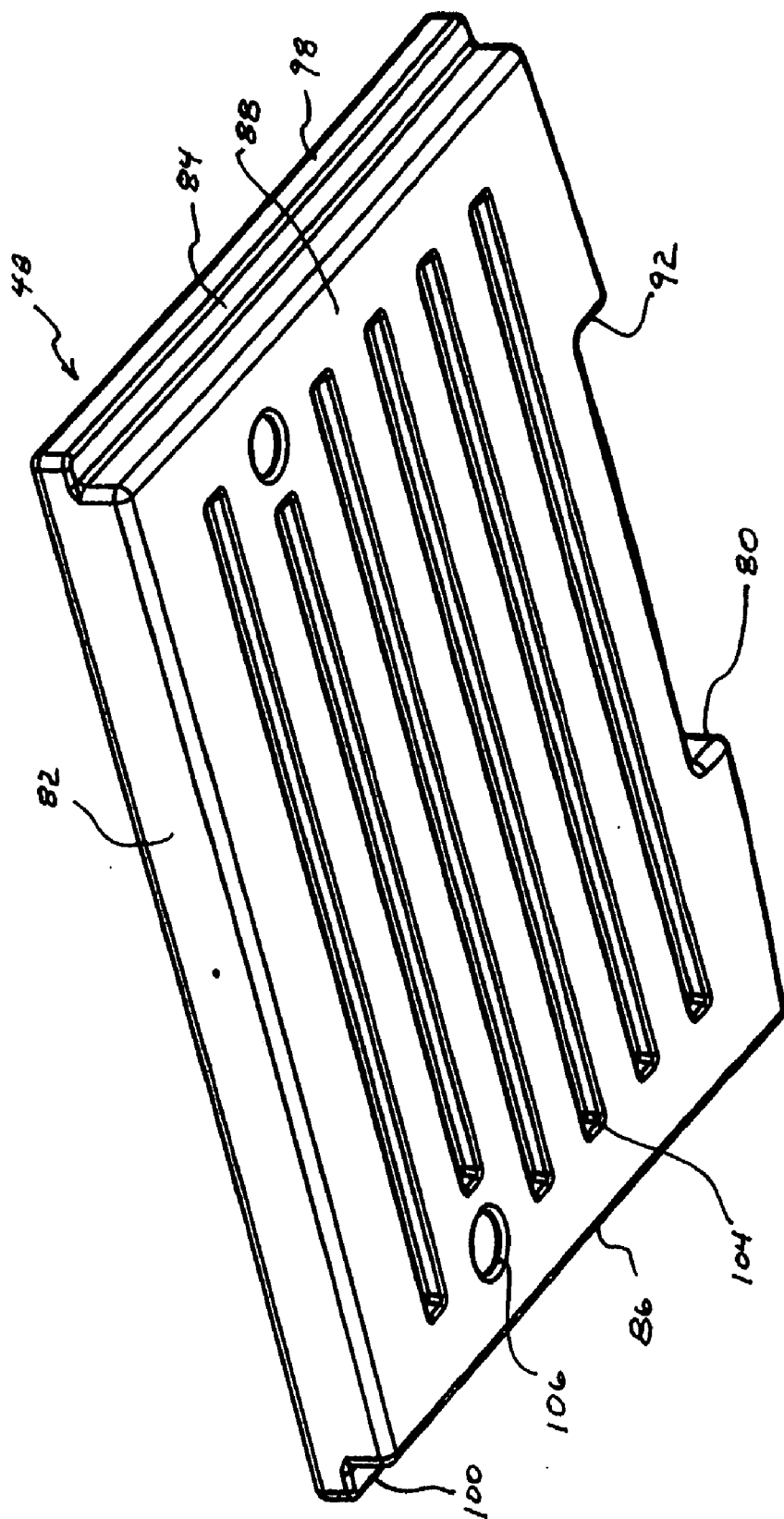

FIGURE 9

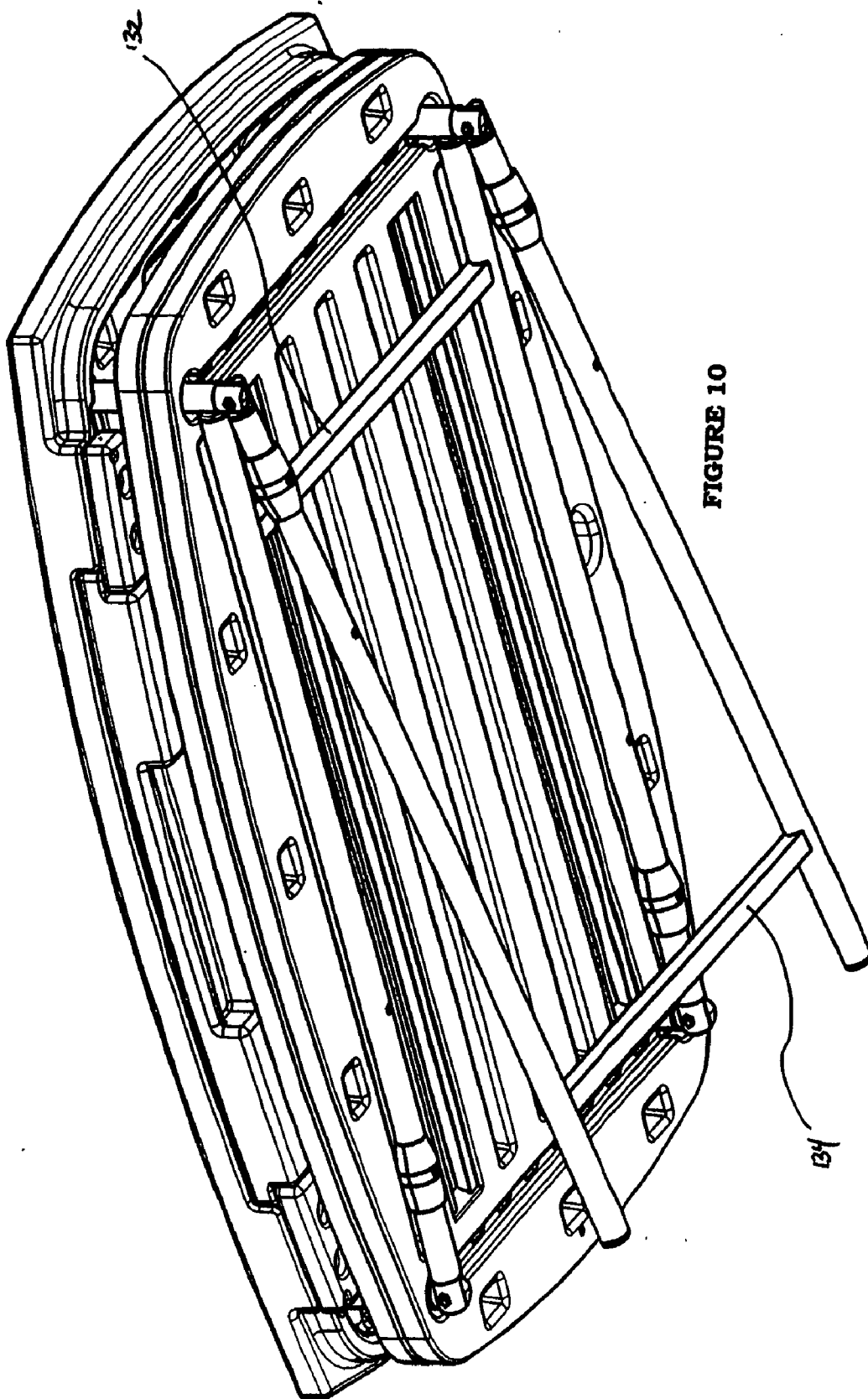

FIGURE 10

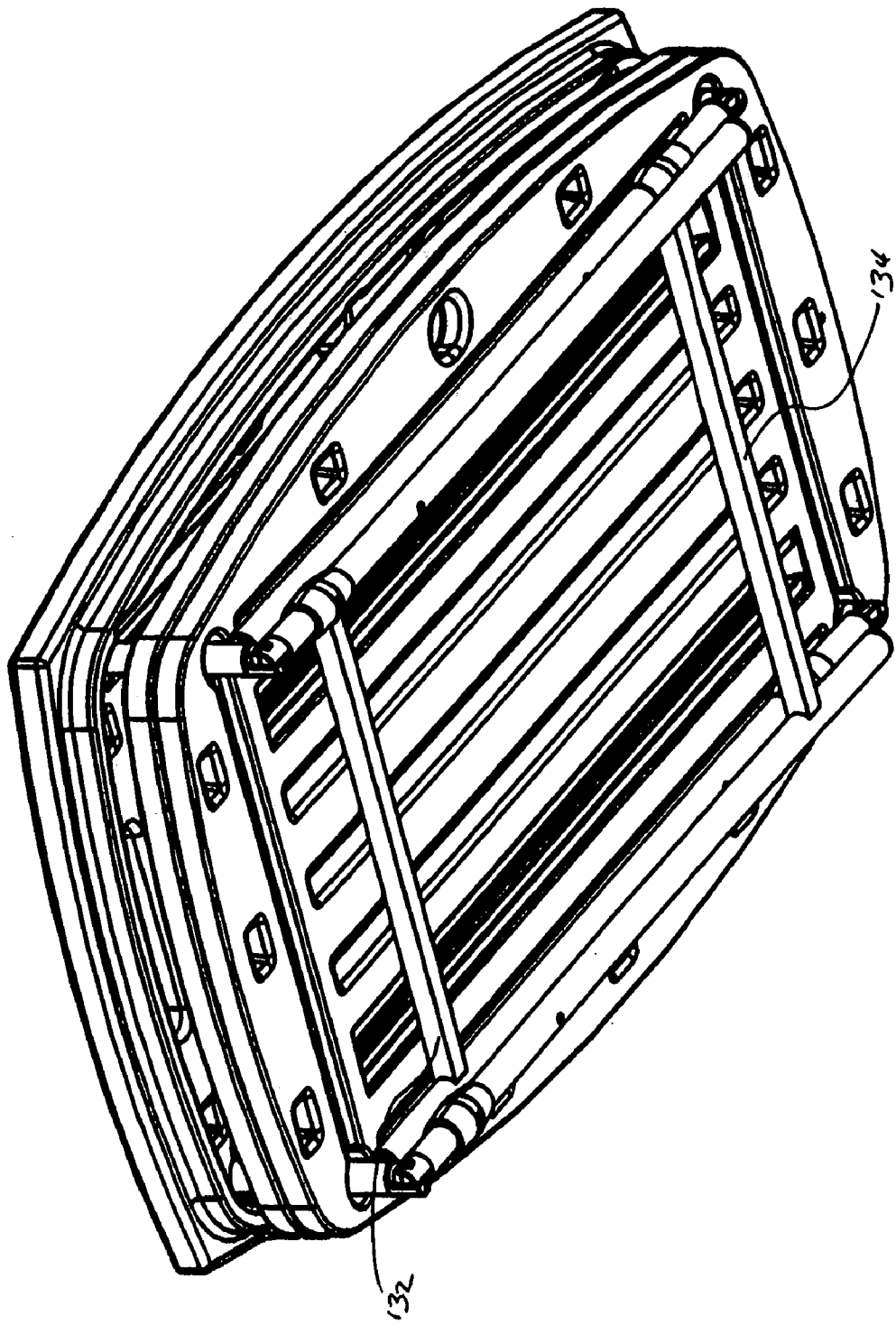

FIGURE 11

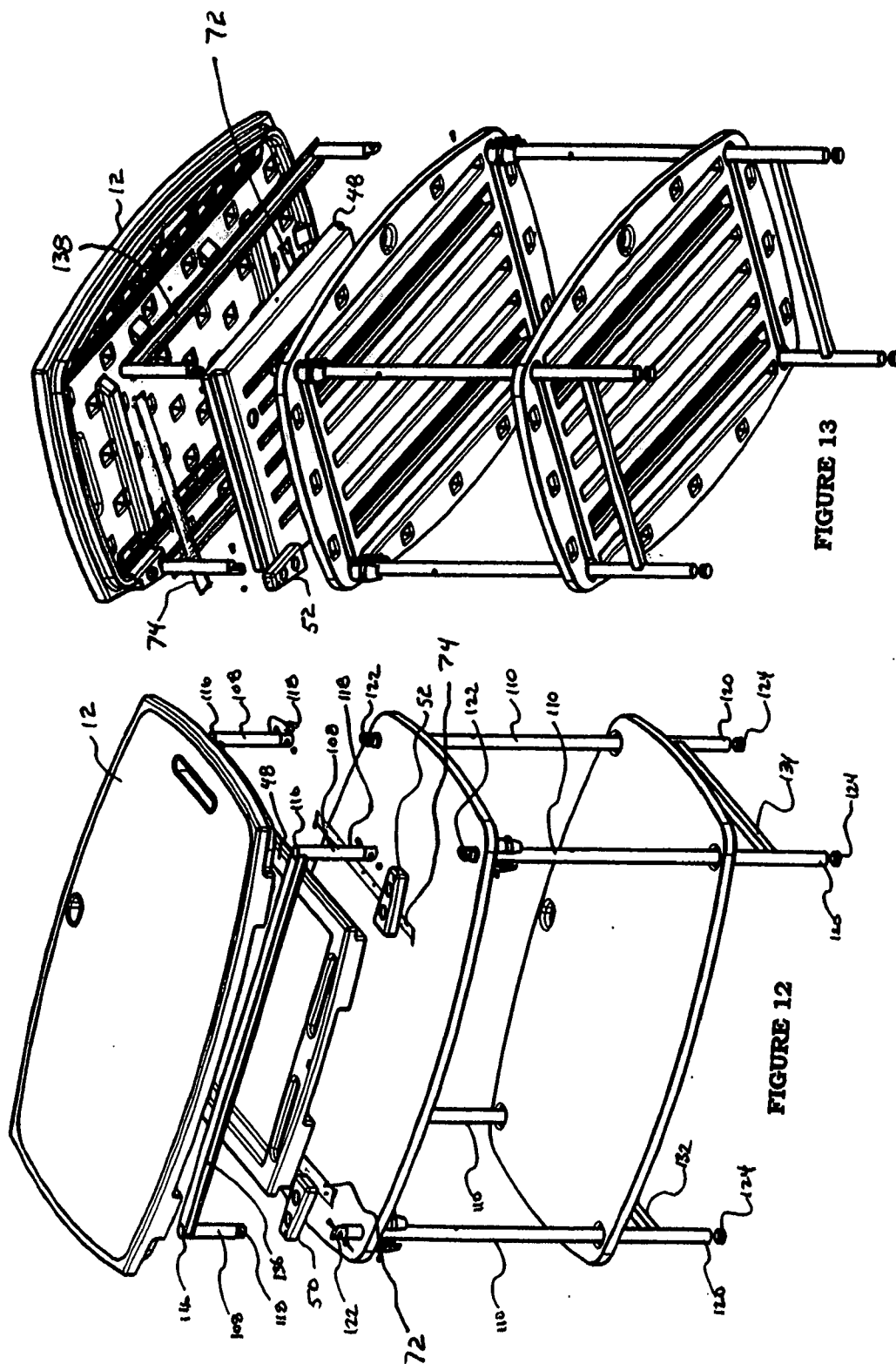

FIGURE 13

FIGURE 12

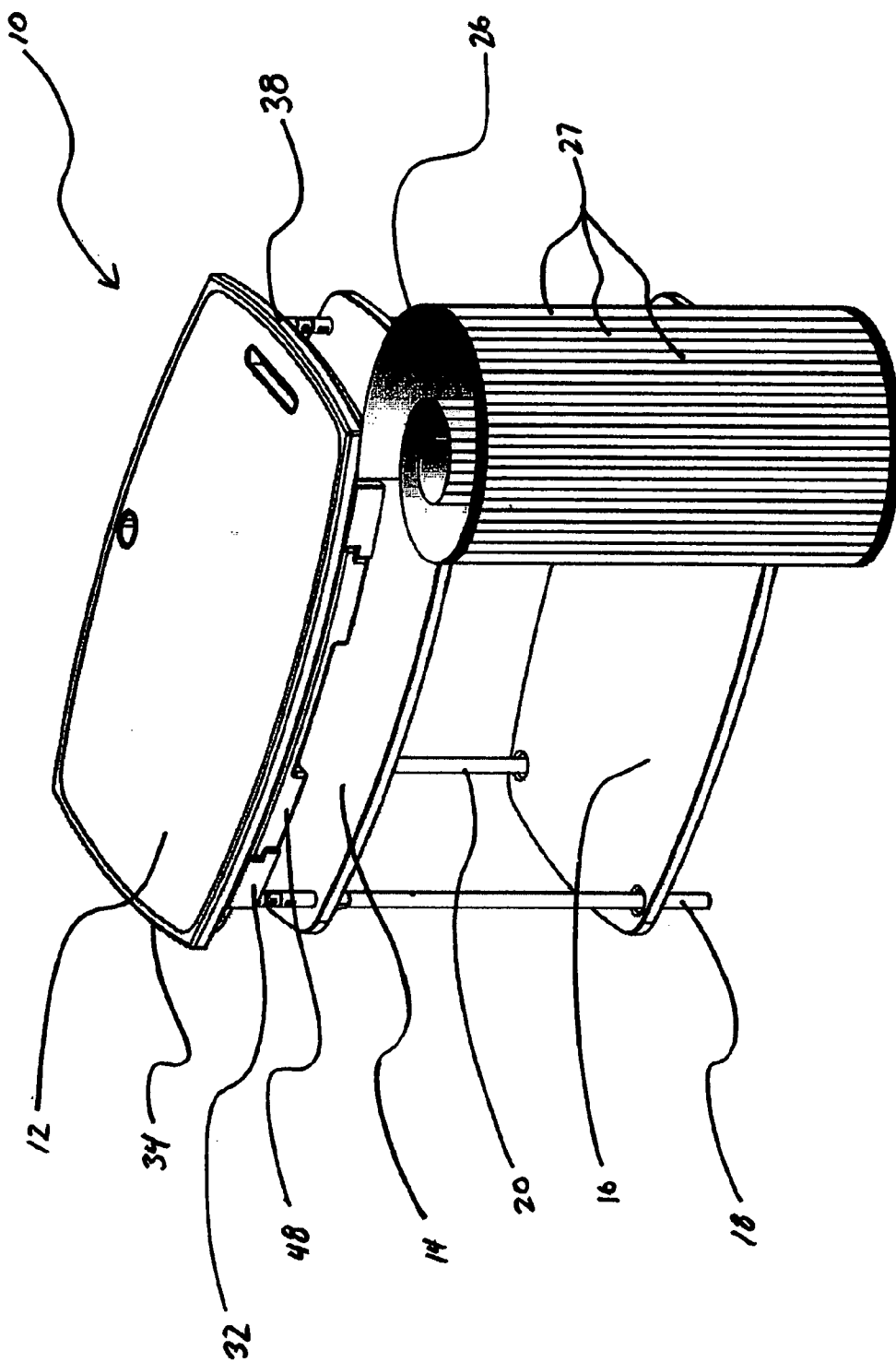

FIGURE 14e

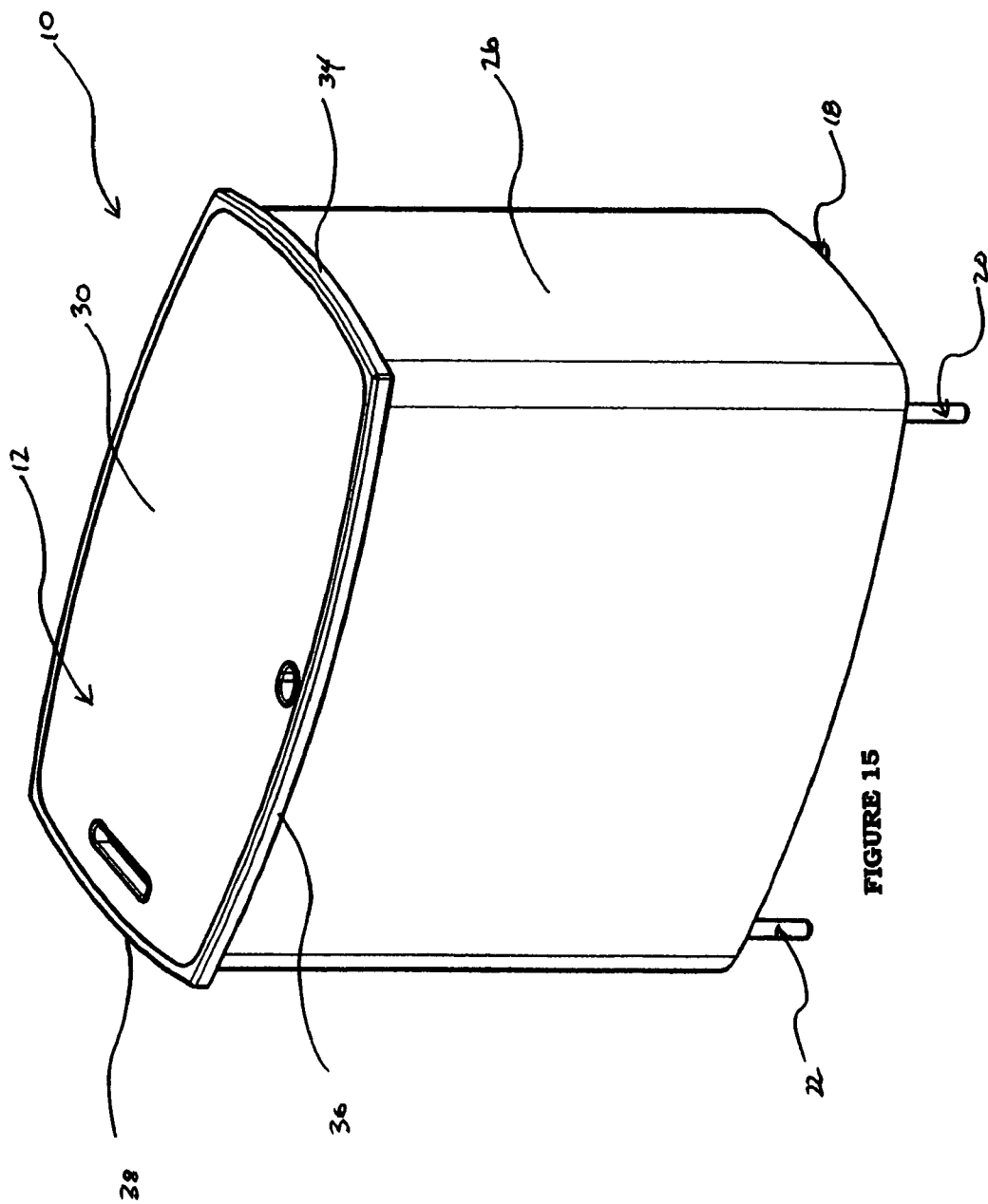

FIGURE 15

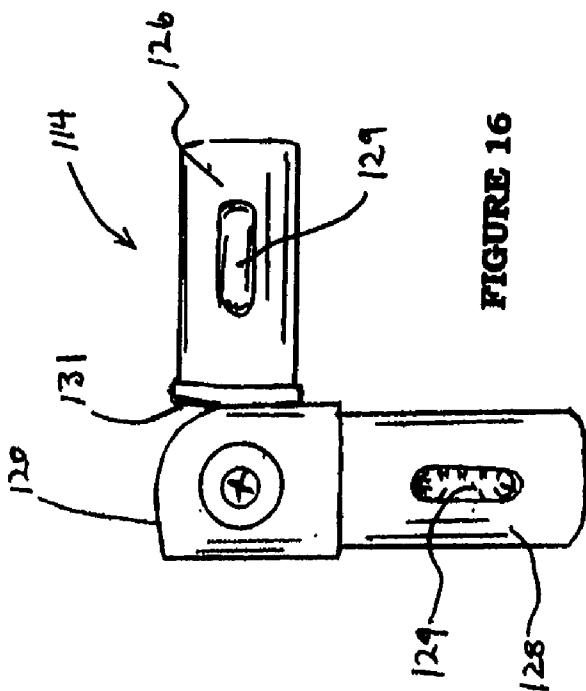

FIGURE 16

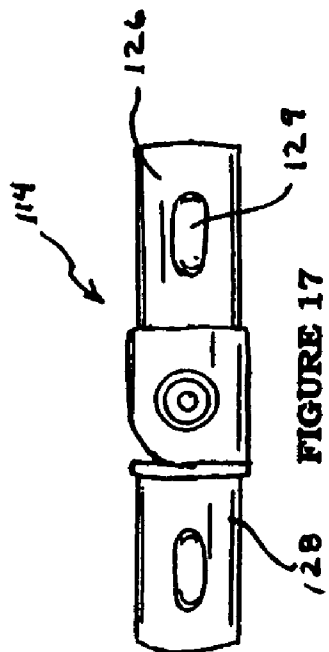

FIGURE 17

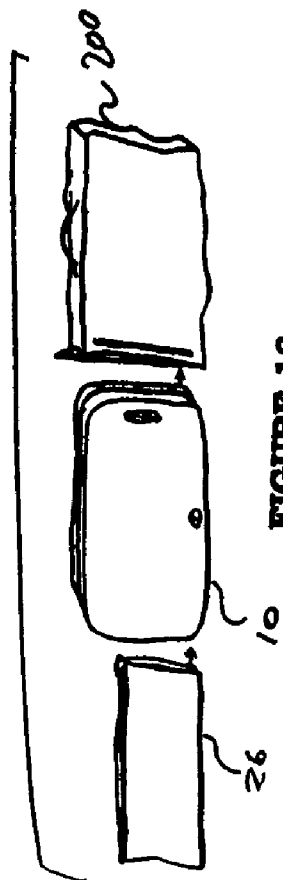

FIGURE 18

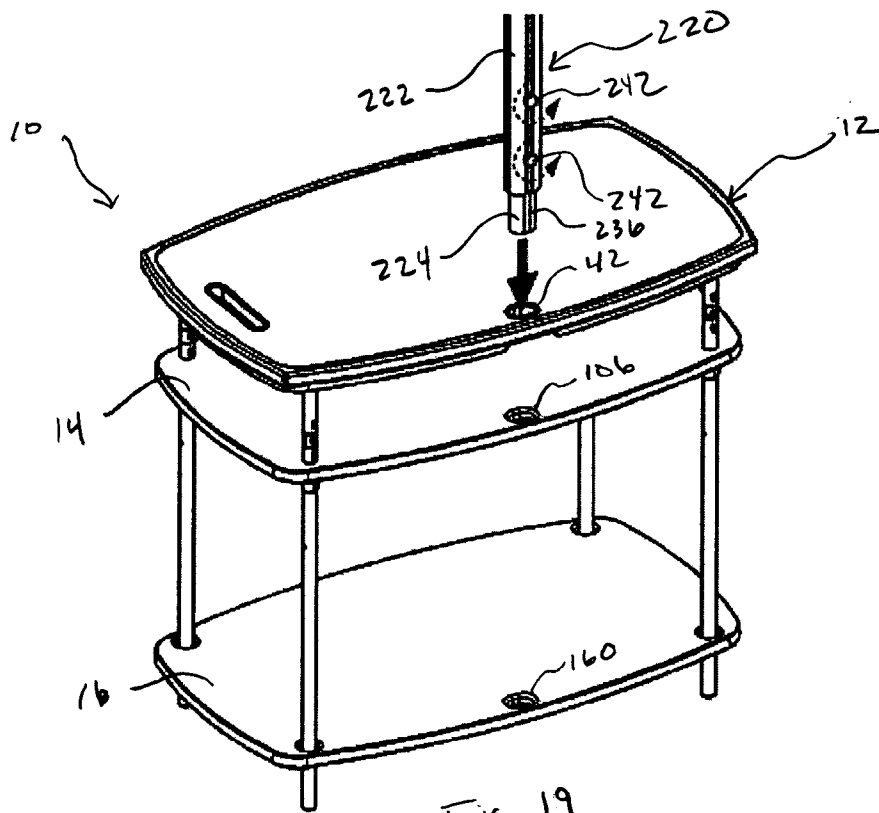

Fig. 19

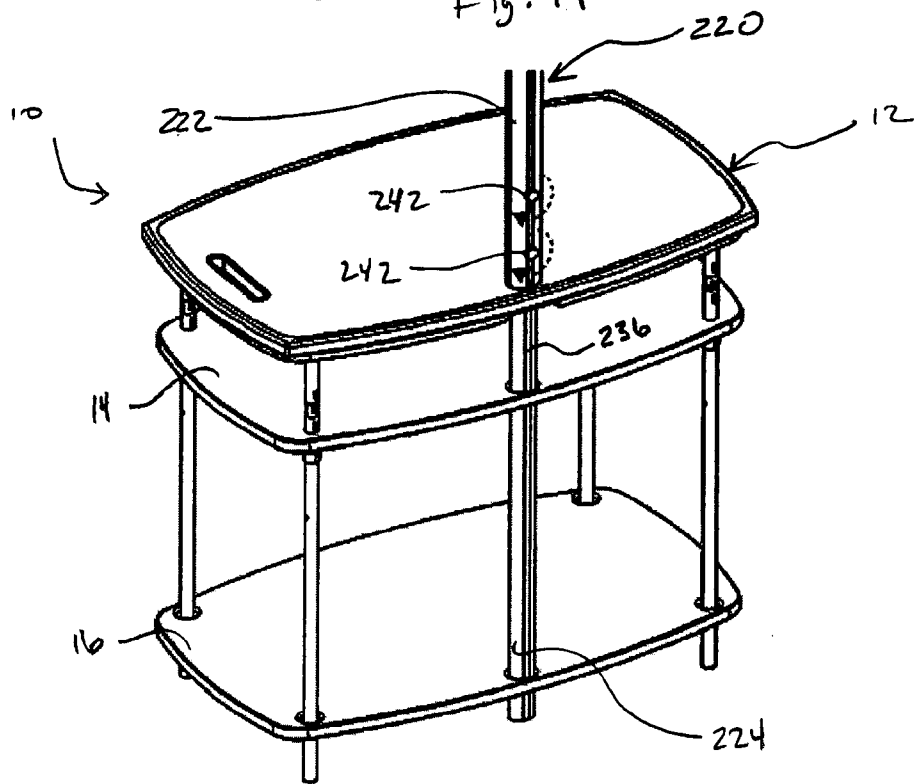

Fig. 20

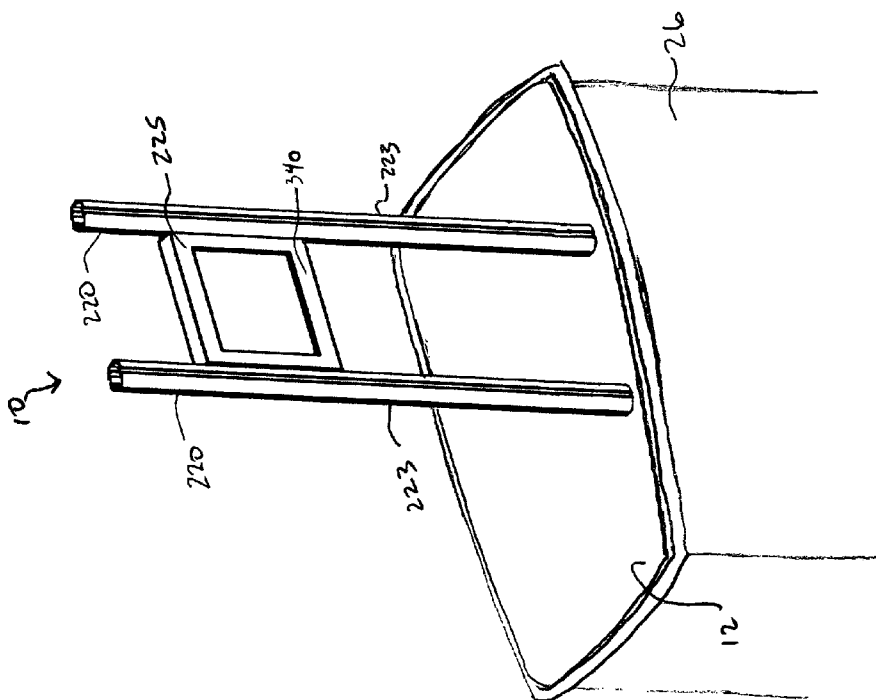

Fig. 20b

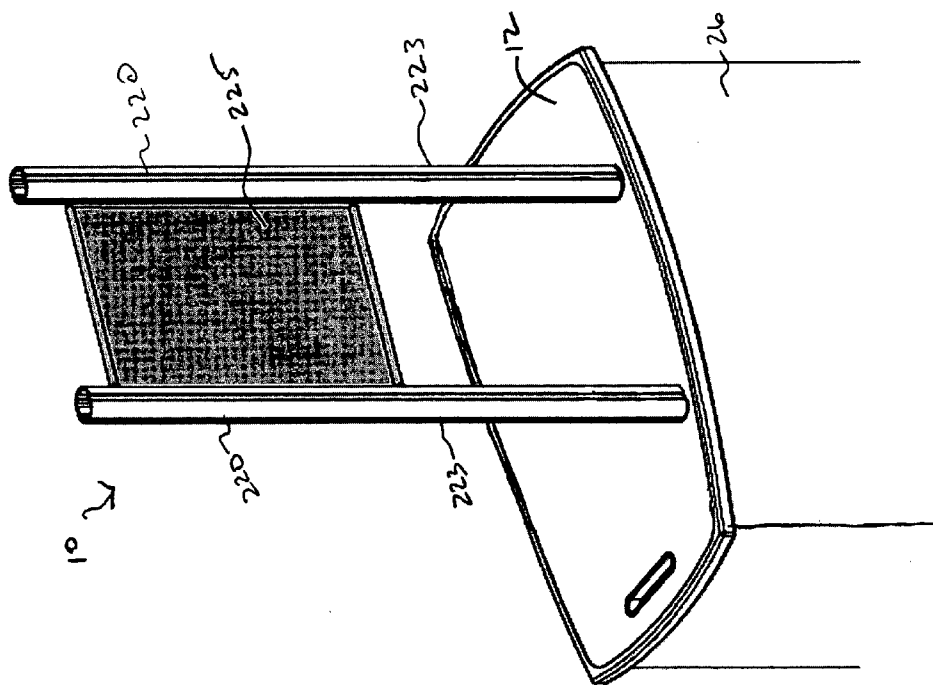
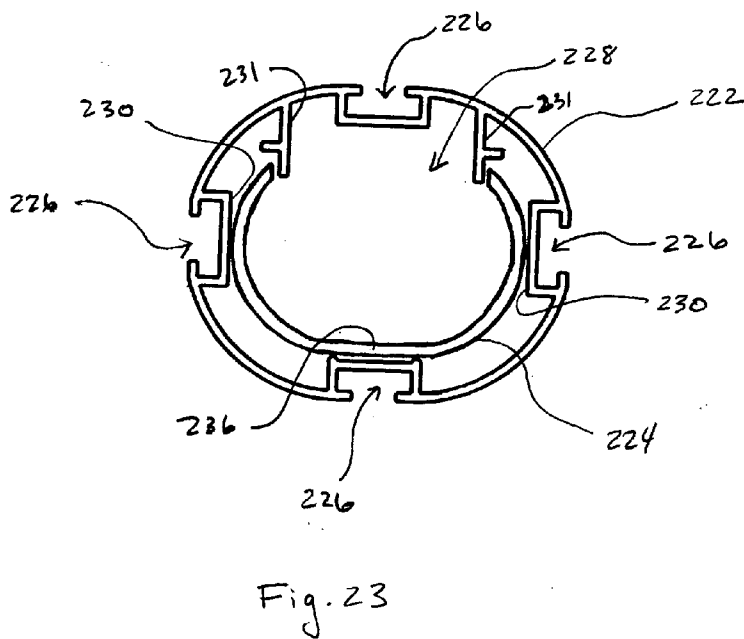
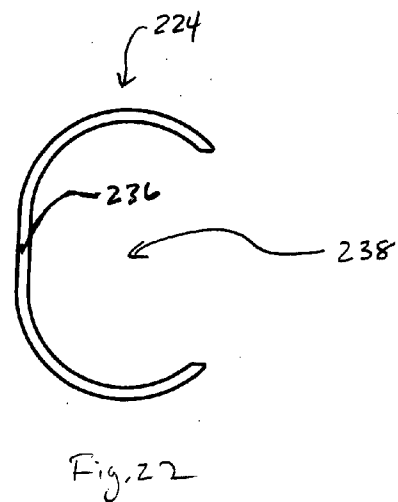
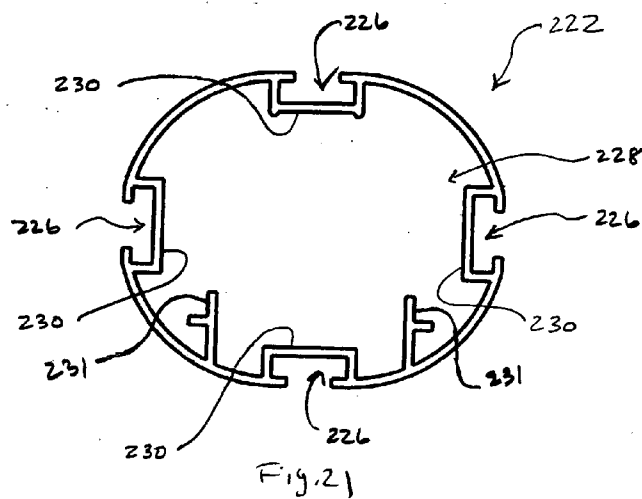

Fig. 20a



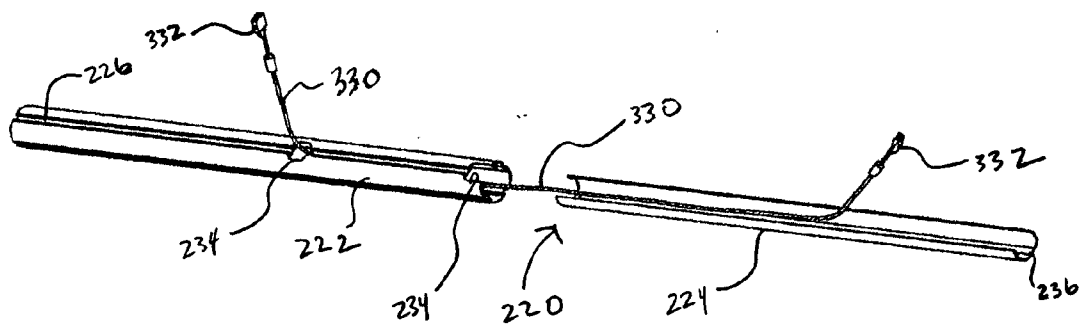

Fig. 24

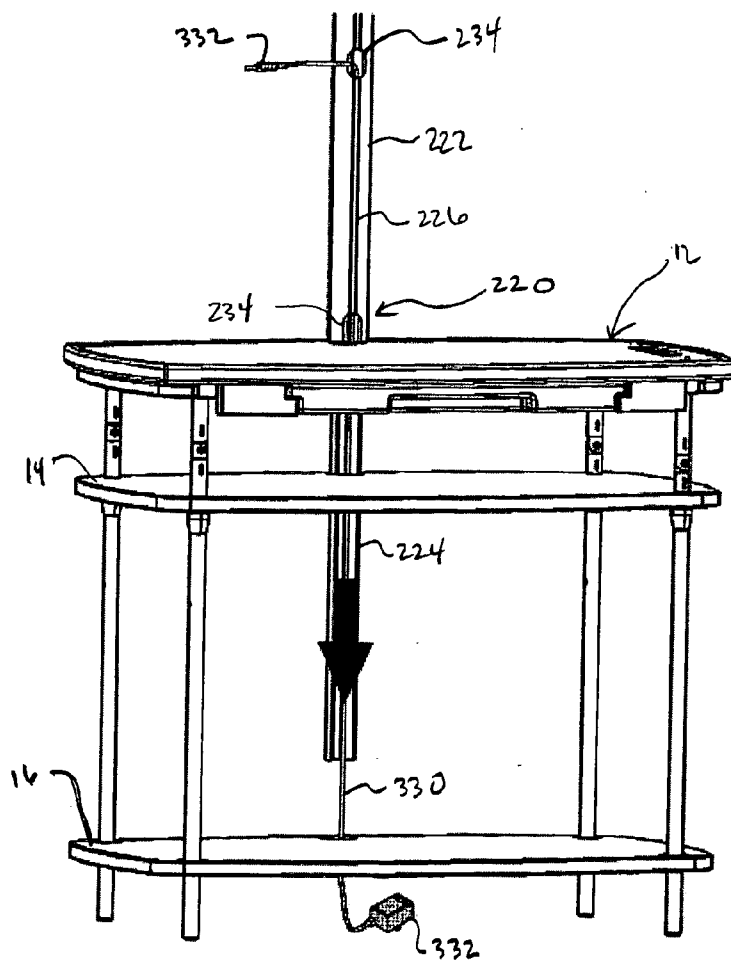

Fig. 25

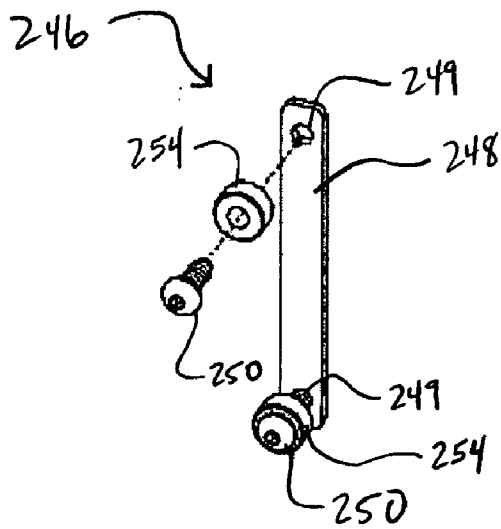

Fig. 26

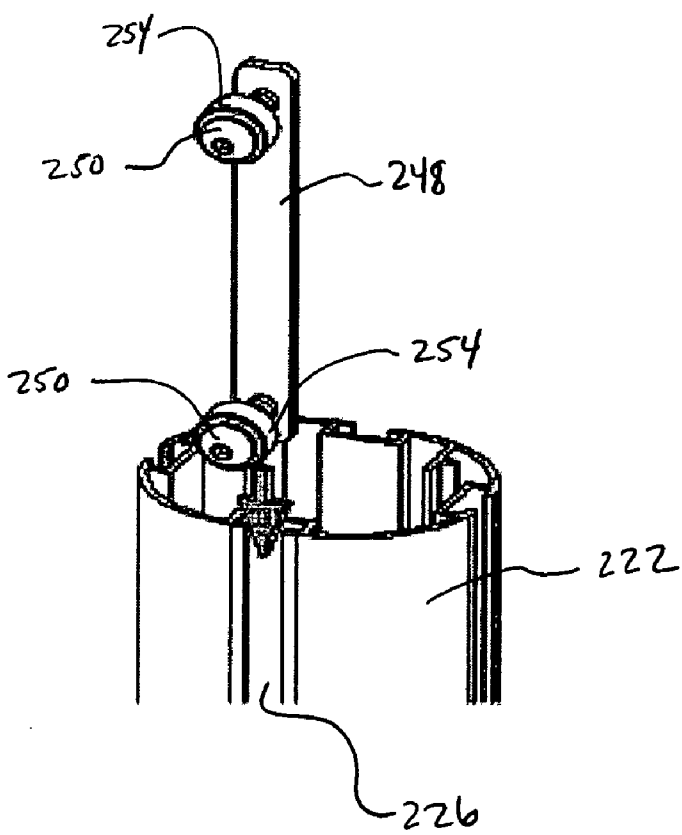

Fig. 27

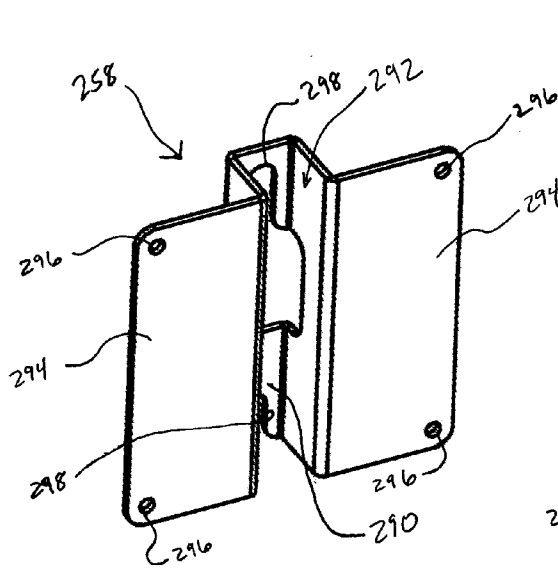

Fig. 29

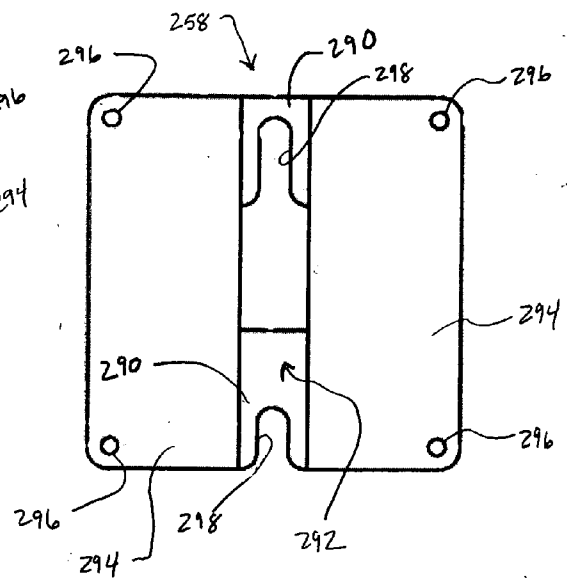

Fig. 30

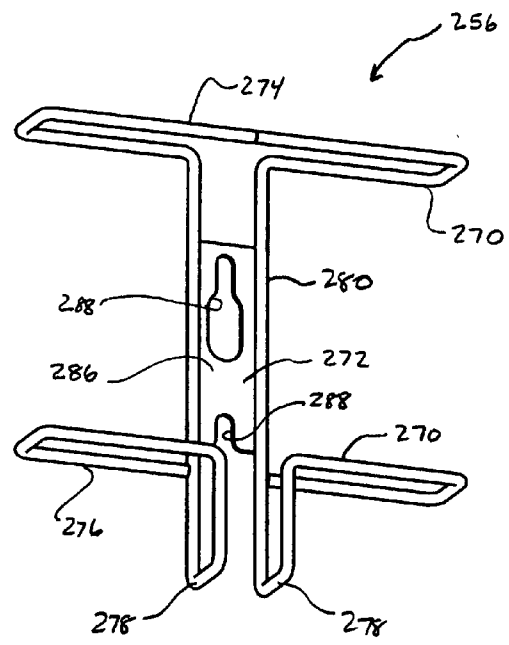

Fig. 28

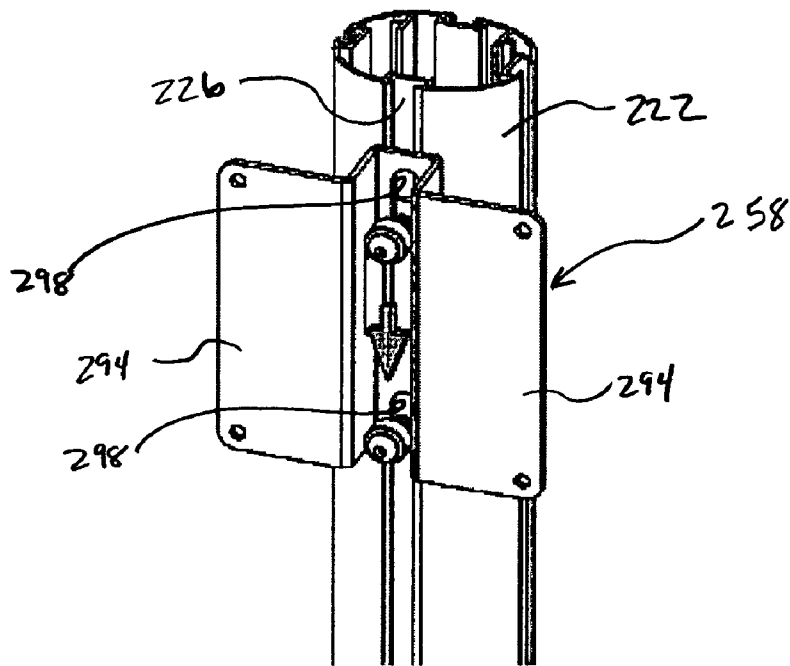

Fig. 32

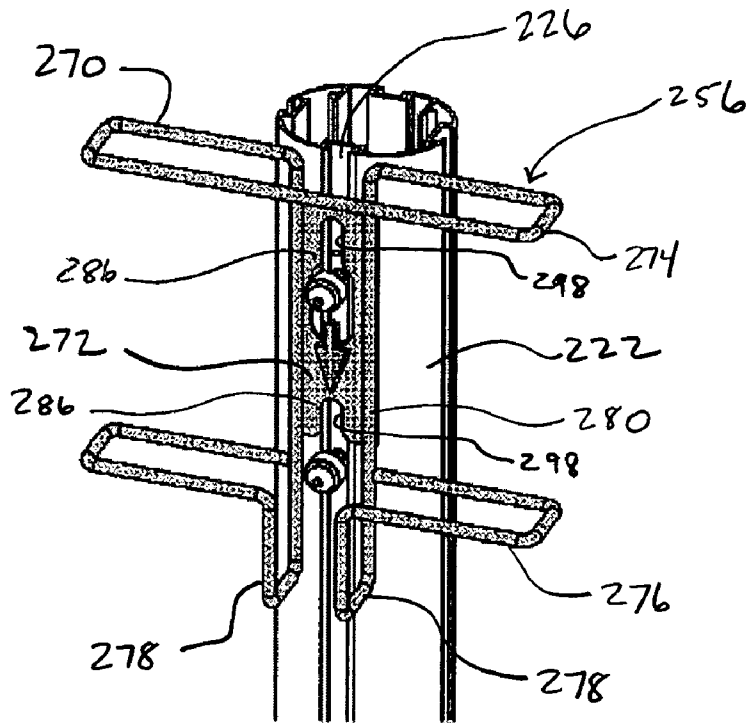

Fig. 31

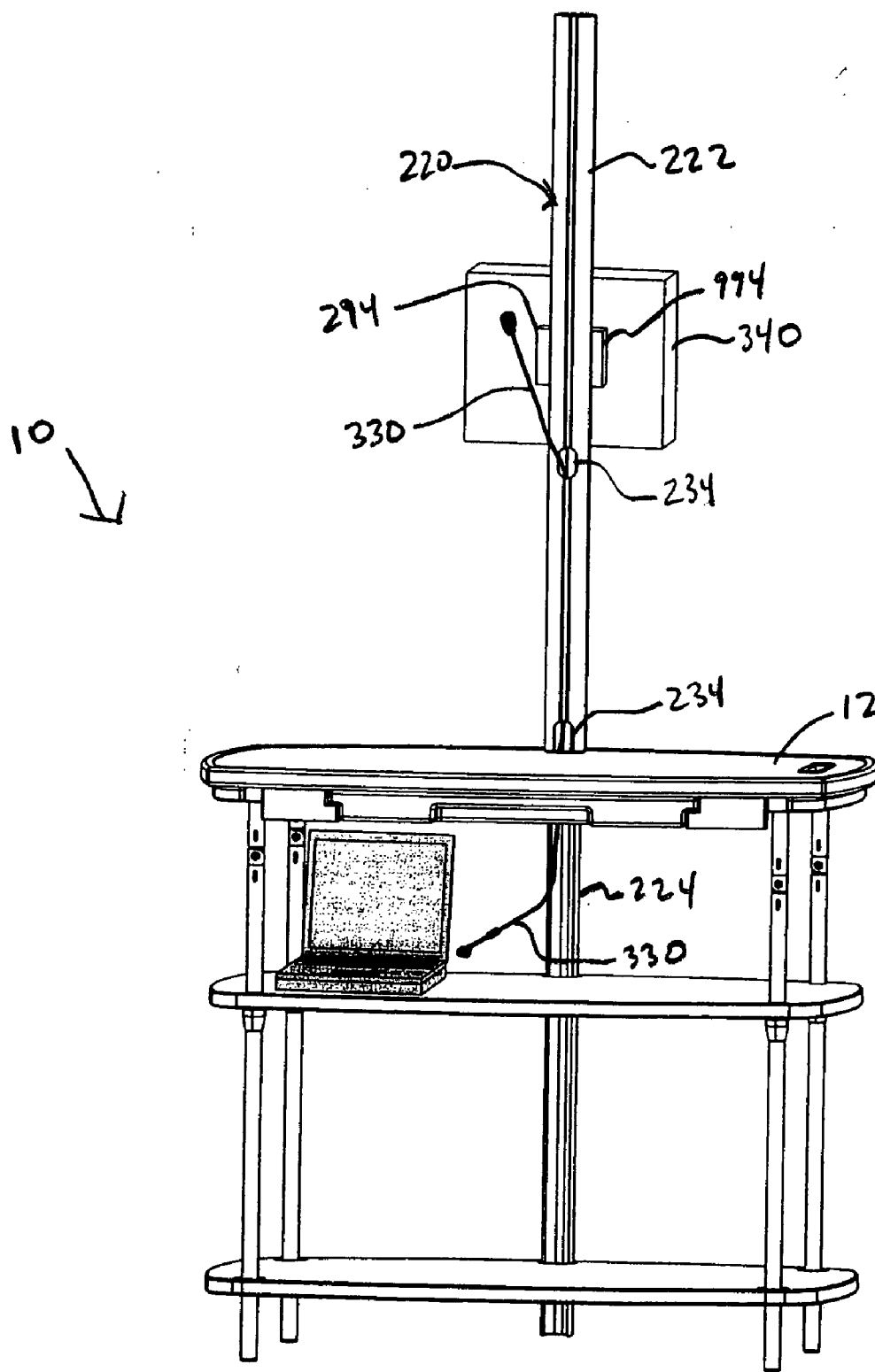

Fig. 33

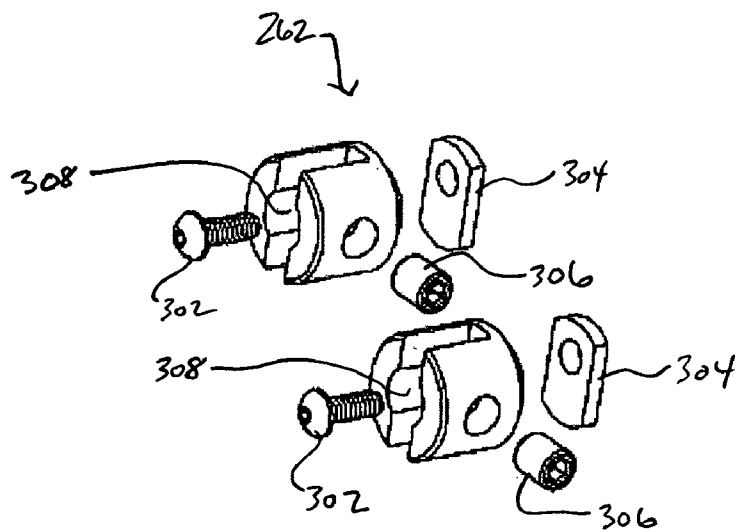

Fig. 34

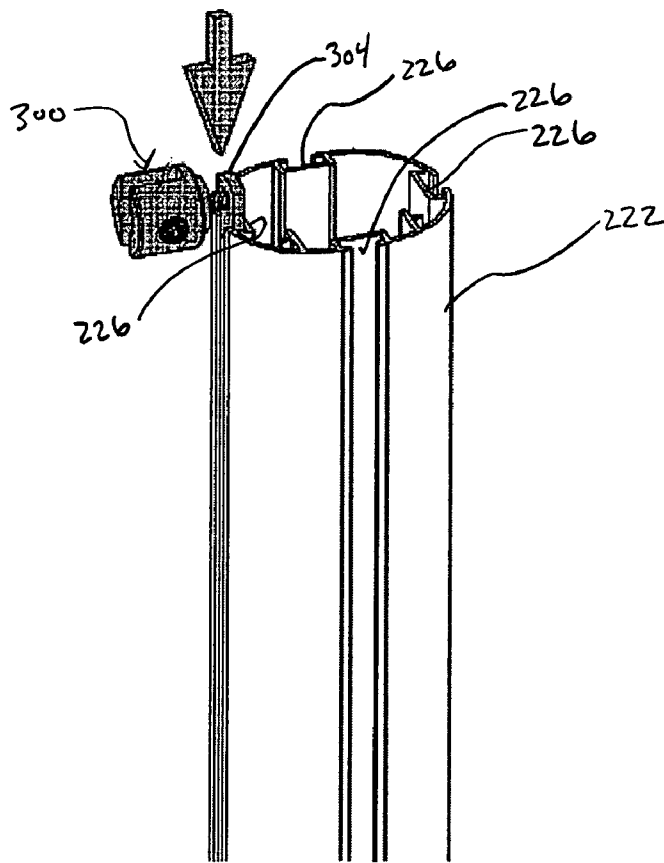

Fig. 35

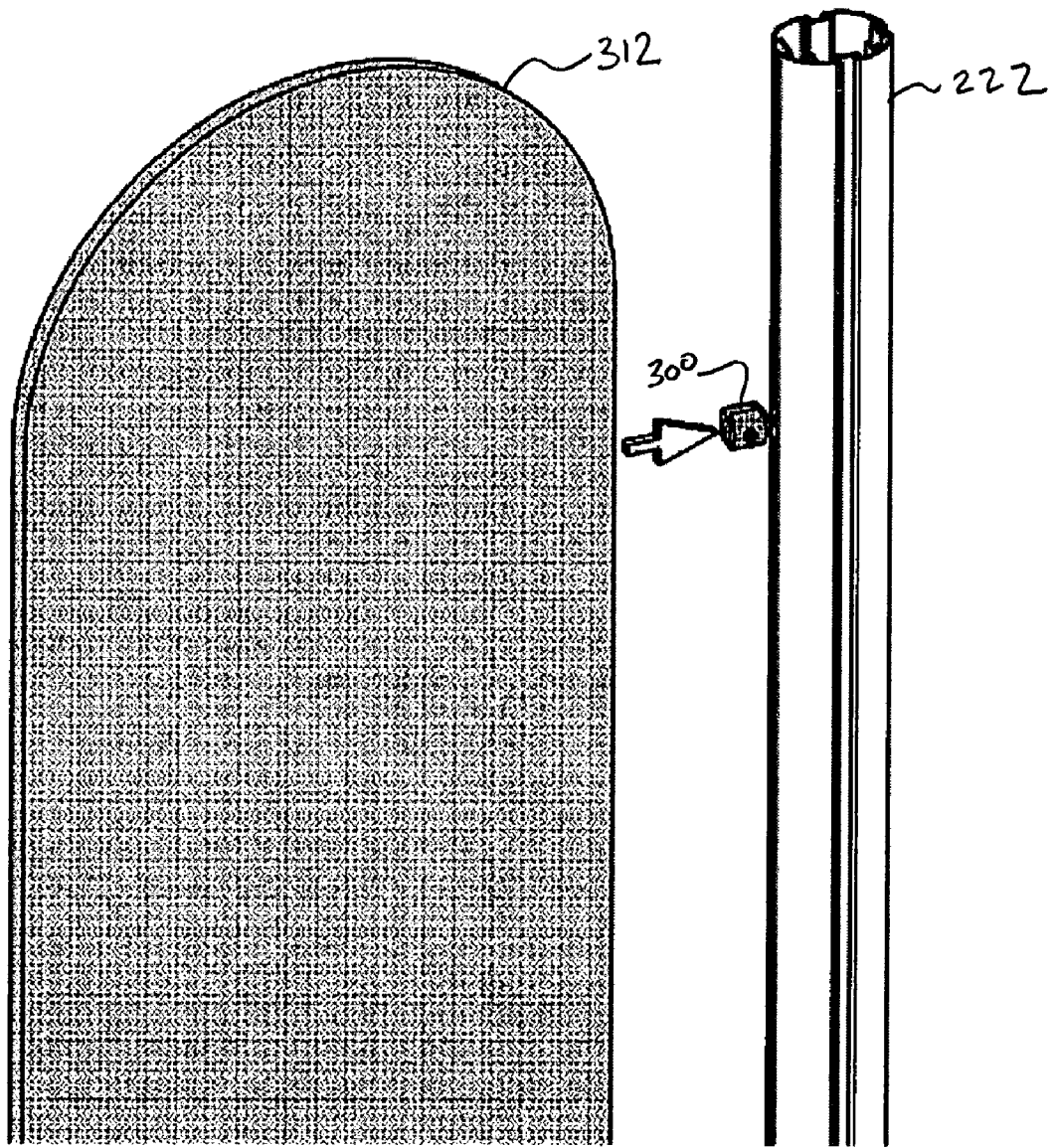

Fig. 3b

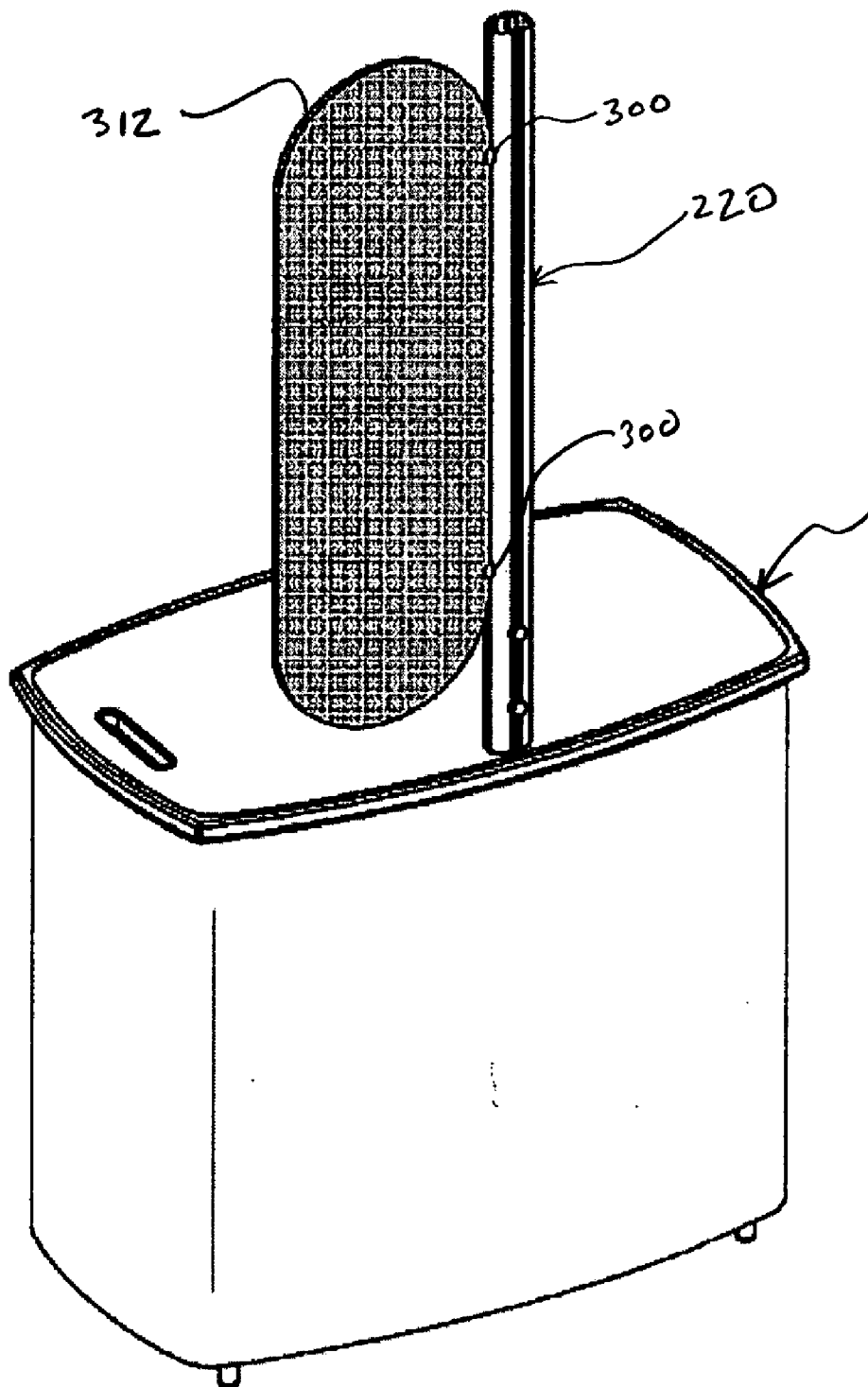

Fig. 37

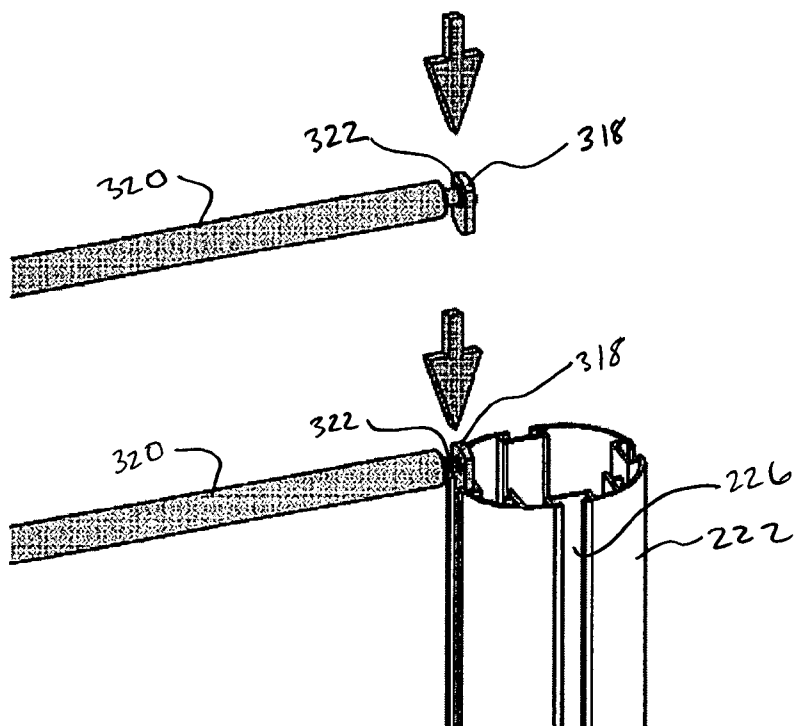

Fig. 38

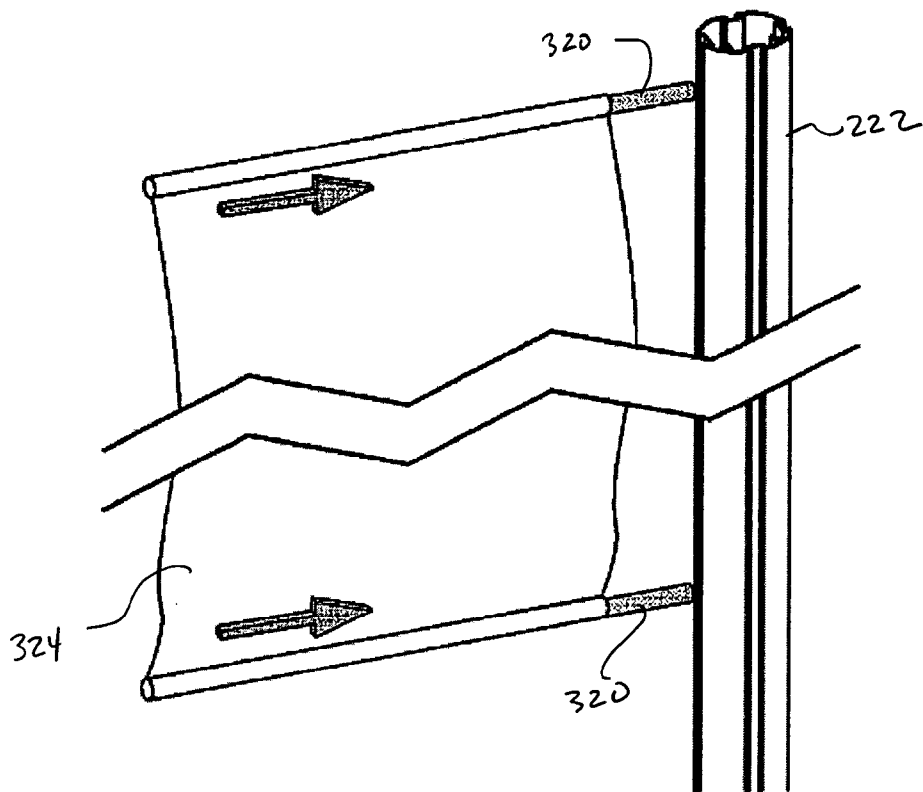

Fig. 39

DISPLAY TABLE WITH ACCESSORY POLE

[0001] This application is a continuation-in-part of U.S. patent application Ser. No. 10/998,508 filed Nov. 29, 2004 and entitled COLLAPSIBLE TABLE, which in turn claims priority to U.S. Provisional Application No. 60/525,704, filed on Nov. 28, 2003 and entitled COLLAPSIBLE TABLE, with each of the referenced applications being incorporated herein by reference in their entirety.

FIELD OF THE INVENTION

[0002] The present invention relates generally to display tables. More particularly, the present invention relates to a display table having at least one adjustably configurable accessory pole or mast that is particularly suitable for use in trade shows, exhibitions and the like.

BACKGROUND OF THE INVENTION

[0003] At tradeshows and other public exhibitions, vendors and salespersons often use collapsible tables to display their products and services. The vendors sometimes bring their own collapsible large banquet-style tables with them if they are traveling by ground and with a vehicle large enough to transport the tables. Alternatively, such tables are often available to vendors by renting them from the facility at which the tradeshow is being held. However, the rental tables are usually expensive to rent. In addition to paying for the tables, the vendors are often also charged for the time and labor that it takes workers to set up and tear down the tables. When the rental tables are not banquet-type tables but rather complex tables requiring some level of assembly, the vendors are usually charged for the time and labor that it takes workers to assemble the tables. Moreover, the rental tables are usually very generic looking and provide no visual impact to tradeshow attendees.

[0004] Conventional collapsible banquet-style tables that are commonly used at tradeshows can be seen in U.S. Pat. Nos. 6,550,404, 6,530,331, 6,431,092, and 6,112,674. The banquet-style tables generally have a large horizontal tabletop and legs that fold up and underneath the table surface. The tables are usually very big and heavy and therefore the portability of such tables is severely limited by the large size of the tabletop. Moreover, the banquet-style tables do not have any storage or shelf space nor do they include any customizable skirts or banners. A vendor can tape or clip on a personalized banner, although if the vendor is renting the table, the owner of the venue may not allow such use of the tables.

[0005] A collapsible display table that addresses some of the above-listed problems is disclosed in U.S. Pat. No. 5,865,127. U.S. Pat. No. 5,865,127 is directed to a collapsible display table with a truss framework that supports a folding tabletop and a shelf. However, other than the shelf, the table according to the '127 patent does not provide a user with very much storage space. In addition, other than the shroud shown in FIG. 16, the table according to U.S. Pat. No. 5,865,127 does not disclose any type of skirt that can be used to add to the visual impact of the table. The table of this patent has many components presenting an assembly procedure which is more difficult and time consuming than is desirable.

[0006] In addition to the above-described deficiencies for collapsible display tables, these conventional tables lack

desired modularity to provide flexible configurations to selectively attach accessories. For instance, while display systems typically allow for the attachment of appurtenances to the framing of the displays, they do not provide flexible attachment to the display tables. Such conventional configurations, therefore, limit the types of accessories employed with the tables. As these display tables are often the focal point of meetings and conversation during an exhibition or trade show, present systems do not optimize the table space as they do not provide the end user with the ability to selectively present graphics, monitors, literature displays and like hardware and signage at the often visible display tables.

[0007] Because the general problems discussed above have not been addressed, there is a current need for a cost-efficient display table that takes up minimal space, that is easily transportable, and that includes an adjustable and multi-configurable accessory attachment system. Such a table would greatly increase the ability of the end user to utilize and uniquely provide configurations in accordance with one's particular needs. For instance, an end user could selectively configure the display table to receive and display various appurtenances, such as monitors, literature materials, banners and the like.

SUMMARY OF THE INVENTION

[0008] The item of furniture according to the present invention provides a vendor end user with a lightweight table that is easy to set up to an erected state and to collapse to a collapsed state and meets the needs described above.

[0009] In preferred embodiments the principal components of the item of furniture are configured as a table and are interconnected and self-contained; the principle components remain part of the assembly in the collapsed state. The table preferably includes the principle components of a tabletop, at least one shelf, a plurality of folding legs and at least one adjustable accessory/appurtenance pole or mast.

[0010] The legs are attached to the tabletop and are foldable between an extended and erected position and a folded and transport position or a collapsed state. The one or more shelves are slidably positioned on the legs and have a nested position adjacent to the underside of the tabletop and a use position. In the use position the shelf locks the extended legs in place. A hinge or pivot point on the legs is positionally displaced down the legs from the lower surface of the tabletop a distance approximately the thickness of the shelf or shelves to define a suitable nesting region for the shelves intermediate the folded legs and the underside of the tabletop.

[0011] A drawer may be attached to the underside of the tabletop or shelves, providing the vendor with multiple places to store samples, brochures, and other materials during the tradeshows. In preferred embodiments, the tabletop, the shelves, and the drawer may be molded of plastics, for example by blow molding.

[0012] In one embodiment, the at least one adjustably configurable accessory pole or mast can include at least an upper post member and a lower post member adapted for telescoping connectivity, and a mounting assembly adapted to connect various appurtenances/accessories to the pole. In addition, the lower post member and upper post member can

be attached together in an end-to-end relationship. The mounting assembly can include brackets, fasteners, apertures, and various other components and techniques for connecting a display device (such as a monitor, signage and the like) to the at least one pole.

[0013] The at least one pole is preferably tubular and includes access apertures and/or slots for receiving and routing wires and cables therethrough. Further, various mounting and bracket assemblies can be included to connect literature racks, computer monitors, graphics and/or banners and the like, depending on the shape, size and configuration of the particular accessory. In one embodiment, the lower post member telescopes from within the upper member and down through apertures in the table such that the upper post member is positioned to extend up a distance from the tabletop. To facilitate attachment of the accessories to the pole, the upper post member can include a plurality of peripheral channels extending along the longitudinal axis of the pole. Other apertures and components can be utilized as well. Bracket and mounting assemblies can be slidably engaged along the peripheral channels to attach the subject accessory at selected positions along the length of the upper post member. The at least one accessory pole and associated mounting components and assemblies can be implemented with the collapsible table disclosed herein as well as other tables utilized in trade shows, exhibitions and a myriad of other environments.

[0014] A feature and advantage of the table is that it is easy to erect and to collapse to the transport configuration by one person.

[0015] A feature and advantage of the preferred embodiments of the invention is that the blow or rotationally molded tabletop and shelves provide a lightweight and structurally strong and robust piece of furniture.

[0016] A feature and advantage of the invention is that a common mold may be used for different shelves. For example the two shelves below the table top in a preferred embodiment may be identical although one uses circumferential stops on the legs to secure it in place and the other uses the horizontal cross member to secure it in place in the erected state.

[0017] A feature and advantage of the preferred embodiment is that the table is inexpensive to manufacture with lower cost materials and minimal labor.

[0018] A feature and advantage of the invention is that at least one configurable accessory pole is provided to facilitate the selective attachment of various display devices and appurtenances to the table, such as monitors and signage.

[0019] A feature and advantage of the invention is that the at least one accessory pole can be constructed of telescoping post members that facilitate easy assembly, disassembly, handling and transporting of the attachment system.

[0020] A feature and advantage of the invention is that the at least one accessory pole is adapted to receive various mounting and bracket assemblies for selectively attaching and positioning graphics and displays, monitors, literature racks, and the like along the length of the extending pole, a distance above a tabletop.

[0021] A feature and advantage of the invention is that the mounting and bracket assemblies can be easily imple-

mented, exchanged with other assemblies, and disassembled to promote ease-of-use and flexible configurations for attaching appurtenances and display devices to the display table.

[0022] A feature and advantage of the invention is that post members of the at least one accessory pole can be tubular and include wire access apertures and slots to facilitate the selective routing and distribution of wiring therethrough.

[0023] By bringing a table according to the present invention, a vendor no longer needs to rent tables at the venue of the tradeshow. Because of its weight and small size in the collapsed state, the table, the accessory pole and the subject appurtenances can easily be transported in the back seat or trunk of a car and can even be brought along on an airplane trip. Without the necessity of having to rent a table, the table according to the present invention is very economical and saves a vendor many rental costs normally associated with attending a tradeshow. In addition, a vendor can use a customizable skirt and the accessory pole on the table that has a visual impact on the tradeshow attendees.

[0024] The invention herein is depicted as a table but it is recognized that other configurations such as collapsible podiums or stack of shelves may also suitably incorporate the invention herein.

BRIEF DESCRIPTION OF THE DRAWINGS

[0025] FIG. 1 is a top front perspective view of a collapsible table according to an embodiment of the present invention;

[0026] FIG. 2 is a top rear perspective view of a collapsible table according to an embodiment of the present invention depicting the collapsible table with a skirt;

[0027] FIG. 3 is a front elevation view of a collapsible table according to an embodiment of the present invention;

[0028] FIG. 4a is a rear elevation view of a collapsible table according to an embodiment of the present invention;

[0029] FIG. 4b is a front elevation view of a collapsible table according to an embodiment of the present invention depicting the first shelf at an alternate position on the legs;

[0030] FIG. 5 is a bottom front perspective view of the tabletop of a collapsible table according to an embodiment of the present invention;

[0031] FIG. 6 is a bottom rear perspective view of the tabletop of a collapsible table according to an embodiment of the present invention;

[0032] FIG. 7 is a bottom rear perspective view of the first shelf of a collapsible table according to an embodiment of the present invention;

[0033] FIG. 8 is a top front perspective view of a drawer according to an embodiment of the present invention;

[0034] FIG. 9 is a bottom rear perspective view of a drawer according to an embodiment of the present invention;

[0035] FIG. 10 is a bottom front perspective view of a collapsible table according to an embodiment of the present invention depicting the foldable legs in a partially nested position;

[0036] FIG. 11 is a bottom side perspective view of a collapsible table according to an embodiment of the present invention depicting the foldable legs in a nested position;

[0037] FIG. 12 is a top front exploded view of a collapsible table according to the present invention;

[0038] FIG. 13 is a bottom front exploded view of a collapsible table according to the present invention;

[0039] FIG. 14a is a top front perspective view of a collapsible table according to the present invention depicting the table with a customizable skirt;

[0040] FIG. 14b is a top front perspective view of a collapsible table according to the present invention depicting the table with a customizable skirt;

[0041] FIG. 15 is a top rear perspective view of a collapsible table according to the present invention depicting the table with a customizable skirt;

[0042] FIG. 16 is a side elevation view of a leg hinge portion according to the present invention depicting the hinge in an extended position; and

[0043] FIG. 17 is a side elevation view of a leg hinge portion according to the present invention depicting the hinge in a folded position.

[0044] FIG. 18 is a perspective view of a kit comprising the invention herein.

[0045] FIG. 19 is a perspective view of a table with telescoping accessory pole or mast in accordance with an embodiment of the present invention.

[0046] FIG. 20 is a perspective view of a table with an extended accessory pole in accordance with an embodiment of the present invention.

[0047] FIG. 20a is a perspective view of a table with two parallel extending accessory poles to mount a display device therebetween in accordance with an embodiment of the present invention.

[0048] FIG. 20b is a perspective view of a table with two parallel extending accessory poles to mount a display device therebetween in accordance with an embodiment of the present invention.

[0049] FIG. 21 is a top elevation view of an accessory pole upper post member in accordance with an embodiment of the present invention.

[0050] FIG. 22 is a top elevation view of an accessory pole lower post member in accordance with an embodiment of the present invention.

[0051] FIG. 23 is a top elevation view of an accessory pole lower post member within an upper post member in accordance with an embodiment of the present invention.

[0052] FIG. 24 is a perspective view of wire distribution through an upper post member and lower post member for an accessory pole in accordance with an embodiment of the present invention.

[0053] FIG. 25 is a perspective view of a table and wire distribution through an upper post member and lower post member for an accessory pole in accordance with an embodiment of the present invention.

[0054] FIG. 26 is a perspective view of mounting plate components in accordance with an embodiment of the present invention.

[0055] FIG. 27 is a perspective view of mounting plate components and an accessory pole upper post member in accordance with an embodiment of the present invention.

[0056] FIG. 28 is a perspective view of a literature mounting assembly in accordance with an embodiment of the present invention.

[0057] FIG. 29 is a perspective view of a monitor mounting assembly in accordance with an embodiment of the present invention.

[0058] FIG. 30 is a front elevation view of a monitor mounting assembly in accordance with an embodiment of the present invention.

[0059] FIG. 31 is perspective view of the attachment of a literature mounting assembly to the upper post member of an accessory pole in accordance with an embodiment of the present invention.

[0060] FIG. 32 is a perspective view of the attachment of a monitor mounting assembly to the upper post member of an accessory pole in accordance with an embodiment of the present invention.

[0061] FIG. 33 is a perspective view of the attachment of a monitor to, and the distribution of wires through an accessory pole for a table in accordance with an embodiment of the present invention.

[0062] FIG. 34 is an exploded perspective view of various components of a display board mounting assembly in accordance with an embodiment of the present invention.

[0063] FIG. 35 is a perspective view of the attachment of various components of a display board mounting assembly to the upper post member of an accessory pole in accordance with an embodiment of the present invention.

[0064] FIG. 36 is a perspective view of the attachment of a display board mounting assembly to the upper post member of an accessory pole in accordance with an embodiment of the present invention.

[0065] FIG. 37 is a perspective view of the attachment of a display board mounting assembly to the upper post member of an accessory pole in accordance with an embodiment of the present invention.

[0066] FIG. 38 is a perspective view of the attachment of various components of a display banner mounting assembly to the upper post member of an accessory pole in accordance with an embodiment of the present invention.

[0067] FIG. 39 is a perspective view of the attachment of a display board mounting assembly to the upper post member of an accessory pole in accordance with an embodiment of the present invention.

DETAILED DESCRIPTION OF THE DRAWINGS

[0068] Referring to FIGS. 1-18, an item of furniture configured as a collapsible table 10 is shown that provides quick and easy setup and takedown and is highly suitable for use at trade shows. The collapsible table 10 according to the present invention preferably comprises a top horizontal

member configured as a tabletop 12, a shelf 14, a secondary shelf 16, a first leg 18, a second leg 20, a third leg 22, and a fourth leg 24. The table also preferably includes a customizable skirt 26 removably attached to the collapsible table 10 as depicted in FIGS. 14a, 14b, and 15.

[0069] Referring to FIGS. 1 and 5, the tabletop 12 includes a working surface 30 and a tabletop underside 40 oriented generally parallel to the working surface 30, a tabletop front side 32, a tabletop left side 34, a tabletop rear side 36, and a tabletop right side 38. The tabletop front side 32, tabletop left side 34, tabletop rear side 36, and tabletop right side 38 define a periphery 40.1. The tabletop 12 according to the present invention further includes a tabletop aperture 42 preferably located proximate the tabletop rear side 36 and intermediate the tabletop left side 34 and tabletop right side 38 positioned for use as a wire conduit or a holder for a post for signage or a video or message screen. A slot 44 located proximate the tabletop right side 38 and intermediate the tabletop front side 32 and tabletop rear side 36 may be used such as for a business card deposit slot. A skirt flange 46 follows the periphery 40.1 at the tabletop underside 40, and a drawer 48 slidably engageable with the tabletop 12.

[0070] As best illustrated in FIGS. 1, 3, 4a, 4b, 12, and 13, the tabletop 12 further includes a left hanger 50 and a right hanger 52 securely mounted to the tabletop underside 40. The hangers are preferably blow-molded or injection molded thermoplastic and are connected to the tabletop underside 40 proximate the tabletop front side 32 using screws. The hangers can also be connected to the tabletop underside 40 with bolts, nails, rivets, by welding or other fastening means. Alternatively, the hangers can be integrally formed with the tabletop 12, for example during the molding process.

[0071] The skirt flange 46 as can be seen in FIG. 5 comprises a flange outer surface 54 and a flange inner surface 56 and is preferably integrally attached to the tabletop 12. The skirt flange 46 projects from the tabletop underside 40 and extends along the tabletop left side 34, tabletop rear side 36, and tabletop right side 38. It is contemplated that the skirt flange 46 be integral with the tabletop 12. The skirt flange 46 may extend fully or partially around the periphery 40.1. There is preferably a plurality of support members 58 that are integral with the flange inner surfaces 56 and the tabletop underside 40 that provide the skirt flange 46 and tabletop 12 with added rigidity and strength.

[0072] Referring to FIGS. 5 and 6, the tabletop includes a first channel 60 and a second channel 62 extending lengthwise on the tabletop underside 40. The first channel 60 is located proximate the tabletop front side 32 and substantially spans between the tabletop left side 34 and the tabletop right side 38. The second channel 62 is located proximate the tabletop rear side 36 and substantially spans intermediate the tabletop left side 34 to the tabletop right side 38. The first channel 60 and the second channel 62 preferably include a plurality of channel touch-offs 64 preferably spaced equidistantly within the channels providing the channels with added stability. The channel touch-offs 64 project upwardly towards the working surface 30 and are preferably rigidly melted or welded to the working surface 30. The channel

touch-offs 64 may come into contact with the working surface 30 without melting or welding to the working surface 30.

[0073] Referring to FIGS. 5, 6, 10, and 13, the tabletop underside 40 further includes a left drawer support 66, a right drawer support 68, and at least one drawer stop 70. The left drawer support 66 and the right drawer support 68 are oriented in a direction from the tabletop front side 32 to the tabletop rear side 36 and the left drawer support 66 and the right drawer support 68 are preferably parallel to one another. The left drawer support 66, right drawer support 68, and at least one drawer stop 70 are preferably integrally attached to the tabletop 12 but can be constructed of metal, thermoplastics, or other conventional materials and rigidly connected to the tabletop 12 with screws, bolts, rivets, or other fastening means. There is preferably a left slide 72 attached to the left drawer support 66 and a right slide 74 rigidly attached to the right drawer support 68. The slides are preferably conventionally constructed of steel or aluminum and are connected to the drawer supports with bolts or screws. The at least one drawer stop 70 is integrally attached to the tabletop underside 40 and is located proximate the tabletop rear side 36 and intermediate the left track 66 and the right track 68. The tabletop underside 40 may further include a latch catch 76 located proximate the tabletop front side 32 and intermediate the left drawer support 66 and the right drawer support 68.

[0074] Still referring to FIGS. 5, 6, 10, and 13, the tabletop underside 40 may include a plurality of tabletop touch-offs 78. The tabletop touch-offs 78 are generally dispersed about the tabletop bottom surface 40 and formed into the tabletop 12 during the manufacturing process to add further stability and support to the tabletop 12. The tabletop touch-offs 78 project upwardly from the tabletop underside 40 towards the working surface 30 and are preferably rigidly melted or welded to the working surface 30. However, it is also contemplated that the tabletop touch-offs 78 come into contact with the working surface 30 without melting or welding to the working surface 30.

[0075] The tabletop 12 is preferably manufactured by blow-molded thermoplastic such as polyethylene. However, it is contemplated that the tabletop 12 be manufactured using injection molding, rotational molding, or other methods of thermoplastic forming. In other embodiments of the present invention, the tabletop 12 and shelves could be constructed of materials such as wood, wood products, metal, or other materials.

[0076] Referring to FIGS. 8 and 9, the drawer 48 has a drawer front edge 80 and a drawer rear edge 82, a drawer left side 84, a drawer right side 86, a drawer top surface 87, and a drawer bottom side 88. The drawer 48 may have an utensil tray 90 located proximate the drawer front edge 80, a drawer handle 92 located on the drawer front edge 80, and a main tray 94 having a tray bottom surface 96. The drawer 48 includes a left flange 98 that projects from the drawer left side 84 and extends from the drawer front edge 80 to the drawer rear edge 82 and a right flange 100 that projects from the drawer right side 86 and extends from the drawer front edge 80 to the drawer rear edge 82. The drawer 48 also preferably includes a latch configured as a detent 102 that projects from the drawer top surface 87 and is located at a position intermediate the drawer left side 84 and the drawer

right side **86**. The drawer bottom side **88** preferably includes a plurality of reinforcing recesses **104**. As shown in **FIGS. 12 and 13**, the plurality of reinforcing recesses **104** are preferably parallel to each other and extend between the drawer left side **84** and the drawer right side **86**. The reinforcing recesses **104** extend between the drawer bottom side **88** and the tray bottom surface **88**. The drawer **48** preferably includes at least one drawer touch-off **106** extending between the drawer bottom side **88** and the tray bottom surface **96**.

[0077] The drawer **48** is slidably engageable with the tabletop **12**. The left flange **98** slidably engages with the left hanger **50** and left slide **72** and the right flange **100** slidably engages with the right hanger **52** and right slide **74**. As the drawer **48** slides from the tabletop front side **32** towards the tabletop rear side **36**, the left flange **98** slidably engages with the left slide **72** and the right flange **100** slidably engages with the right slide **74**. The drawer **48** preferably slides completely into the tabletop **12** until the drawer rear edge **82** comes into contact with the at least one drawer stop **70**. When the drawer **48** is completely into the tabletop **12**, as seen in **FIG. 1**, the drawer rear edge **82** is in contact with the at least one drawer stop **70** and the drawer front edge **80** is preferably flush with the tabletop front side **32**. The drawer **48** rests on the left hanger **50**, the right hanger **52**, the left slide **72**, and the right slide **74**. The detent **102** engages with the latch catch **76** to prevent the drawer **48** from freely sliding out of the tabletop **12**.

[0078] The drawer **48** is preferably blow molded thermoplastic. However, the drawer **48** could alternatively be manufactured using injection molding, rotational molding, or other methods of thermoplastic forming. In other embodiments of the present invention, the drawer **48** could be constructed of materials such as wood, metal or wood products.

[0079] Referring to **FIGS. 1, 2, 3, 10, 11, 12, and 13**, the plurality of legs comprises the first leg **18**, the second leg **20**, the third leg **22**, and the fourth leg **24**. Each includes a proximal or top portion **108**, a distal or bottom portion **110**, a stop portion **112**, and a pivot or hinge portion **114**. As seen in **FIG. 12**, each top portion **108** includes a head **116** and a top hinge end **118**. Each bottom portion **110** includes a foot **120** and a bottom hinge end **122**. The foot **120** preferably includes a foot cap **124** slidably engageable with the foot **120**.

[0080] The hinge portion **114** can be seen in **FIGS. 16 and 17** and includes a top hinge portion **126** and a bottom hinge portion **128** each with attachment divots **129**. The top hinge portion **126** and the bottom hinge portion **128** are pivotally attached with a pin or bolt. The bottom hinge portion **128** has a stop surface **120** that cooperates with a stop surface **131** on the top hinge portion **126** to allow the hinge to open to only 180°. The bottom hinge portion **128** is slidably joined to the bottom hinge end **122** and the top hinge portion **126** is slidably joined to the top hinge end **118**. When the hinge portion **114** is joined to the top portion **108** and the bottom portion **110**, the top portion **108** and the bottom portion **110** are pivotable about the pin or bolt connecting the top hinge portion **126** and the bottom hinge portion **128**. The top portions **108** and the bottom portions **110** of the second leg **20**, third leg **22**, and fourth leg **24** are preferably connected in a similar manner.

[0081] The top portion **108** of each leg is preferably shorter than the bottom portion **110**. The overall length of the first leg **18**, the second leg **20**, the third leg **22**, and the fourth leg **24** are preferably equal. The top portions **108** of the first leg **18** and the second leg **20** are preferably equal in length and preferably slightly shorter than the top portions **108** of the third leg **22** and the fourth leg **24**. The bottom portions **110** of the third leg **22** and the fourth leg **24** are preferably equal in length and slightly shorter than the bottom portions **110** of the first leg **18** and the second leg **20**. The first leg **18**, second leg **20**, third leg **22**, and fourth leg **24** each include a stop portion **112** located proximate the bottom hinge ends **122**. The stop portion **112** is preferably comprised of a first half **129** and a second half **130** and the stop portions **112** are generally connected to the legs with a bolt or screw.

[0082] The first leg **18**, second leg **20**, third leg **22**, and fourth leg **24** are preferably constructed of steel tubing and can be attached to the hinge portion by inserting the top or bottom hinge portion inside the tubing and deforming the tubing at the divots, but can be constructed of other metals, thermoplastics, wood, composite, or other suitable materials.

[0083] The first leg **18** is preferably rigidly connected to the second leg **20** with a first support bar **132**. The third leg **22** is preferably rigidly connected to the fourth leg **24** with a second support bar **134**. The first support bar **132** and the second support bar **134** are preferably constructed of tubular steel but could be constructed of other metals, thermoplastics, wood, or other suitable materials. The legs can be connected to the support bars using a number of different methods, including but not limited to weldments, screws, bolts, clamps or other connecting means.

[0084] The first leg **18** is rigidly connected to the fourth leg **24** with a first connection member **136**. The second leg **20** is rigidly connected to the third leg **22** with a second connection member **138**. The first connection member **136** and second connection member **138** are preferably constructed of stamped steel but could be constructed of aluminum, thermoplastic, wood, or wood products. The first leg **18** could also be hingedly attached to the fourth leg **24** with the first connection member **136** and the second leg **20** could be hingedly attached to the third leg **22** with the second connection member **138**.

[0085] The first connection member **136** and the second connection member **138** are rigidly connected to the tabletop **12**. The first connection member **136** slidably engages with the first channel **60** and the second connection member **138** slidably engages with the second channel **62**. The first connection member **136** and second connection member **138** are then preferably rigidly connected to the channels with screws or bolts.

[0086] Referring to the figures, particularly **FIGS. 1, 7, 12, and 13**, details of the shelves **14** and **16** are illustrated. The shelves include a shelf top surface **140**, a shelf bottom surface **142**, a shelf front edge **144**, a shelf rear edge **146**, a shelf left side **148**, and a shelf right side **150**. The shelf top surface **140** and the shelf bottom surface **142** are generally parallel or have parallel portions to each other. The shelf front edge **144**, shelf rear edge **146**, shelf left side **148**, and shelf right side are generally oriented perpendicularly to the shelf top surface **140** and the shelf bottom surface **150**. The shelf also preferably includes a first leg aperture **152**, a

second leg aperture **154**, a third leg aperture **156**, a fourth leg aperture **158**, and shelf orifice **160**. The first leg aperture **152** is located proximate the intersection of the shelf front edge **144** and the shelf left side **148**. The second leg aperture **154** is located proximate the intersection of the shelf left side **148** and the shelf rear edge **146**. The third leg aperture **156** is located proximate the intersection of the shelf rear edge **146** and the shelf right side **150**. The fourth leg aperture **158** is located proximate the intersection of the shelf right side **150** and the shelf front edge **144**. The leg apertures are preferably slightly smaller in size than the stop portions **112**. It is contemplated that the leg apertures comprise a grommet that is slidably inserted into the apertures. The shelf also includes a shelf orifice **160** that, as shown in the figures, is located proximate the tabletop rear edge **146** and intermediate the shelf left side **148** and the shelf right side **150**, but could be located on any portion of the shelf **14**.

[0087] The shelf bottom surface **142** includes a first support bar cutout **162** and a second support bar cutout **164**. The first support bar cutout **162** preferably spans the distance between the first leg aperture **152** and the second leg aperture **154** and is substantially the same size as the first support bar **132**. The second support bar cutout **164** spans the distance between the third leg aperture **156** and the fourth leg aperture **158** and is substantially the same size as the second support bar **134**. The first support bar cutout **162** and a second support bar cutout **164** preferably include a plurality of cutout touch-offs **166** providing the cutouts with added stability. The cutout touch-offs **166** project upwardly from the cutouts to the shelf top surface **140** and are preferably rigidly melted or welded to the shelf top surface **140**. However, it is also contemplated that the cutout touch-offs **166** come into contact with the shelf top surface **140** without melting or welding to the shelf top surface **140**.

[0088] The shelf bottom surface **142** further preferably includes at least one strengthening recess **168**. The at least one strengthening recess **168** preferably spans a distance slightly less than the distance between the first support bar cutout **162** and the second support bar cutout **164**. The at least one strengthening recess **168** projects upwardly from the shelf bottom surface **142** and are preferably rigidly melted or welded to the shelf top surface **140**. However, it is also contemplated that the at least one strengthening recess **168** comes into contact with the shelf top surface **140** without melting or welding to the shelf top surface **140**.

[0089] The shelf bottom surface **142** further includes a plurality of shelf touch-offs **170** preferably located around the perimeter of the shelf **14**. The shelf touch-offs **170** are generally formed in the shelf **14** during the manufacturing process and add further stability and support to the shelf **14**. The shelf touch-offs **170** project upwardly from the shelf bottom surface **142** towards the shelf top surface **140** and are preferably rigidly melted or welded to the shelf top surface **140**. However, it is also contemplated that the shelf touch-offs **170** come into contact with the shelf top surface **140** without melting or welding to the shelf top surface **140**.

[0090] The secondary shelf **16** has substantially the same structure as the shelf **14**. The secondary shelf **16** includes a first leg aperture **152**, a second leg aperture **154**, a third leg aperture **156**, a fourth leg aperture **158**, and a shelf orifice **160**. The leg apertures on the secondary shelf are larger than the stop portions **112**. The bottom surface **142** on the

secondary shelf **16** also includes a first support bar cutout **162**, a second support bar cutout **164**, at least one strengthening recess **168**, and a plurality of shelf touch-offs **170**. Because the shelf **14** and the secondary shelf **16** include substantially the same features, the shelf **14** and the secondary shelf **16** can be interchangeable.

[0091] The shelf **14** and secondary shelf **16** are preferably blow molded thermoplastic, such as polyethylene. However, the shelf **14** and secondary shelf **16** could alternatively be manufactured using injection molding, rotational molding, or other methods of thermoplastic forming. In one embodiment of the present invention the shelf **14** and secondary shelf **16** could be constructed of materials such as metal, wood, or wood products.

[0092] The customizable skirt **26** is depicted in FIGS. **14a**, **14b**, and **15**. The skirt **26** is preferably removably connected to the skirt flange **46** using hook and loop fasteners ("Velcro®"). It is contemplated that the skirt **26** be connected to the skirt flange **46** in a number of other ways, including but not limited to, magnetic strips, clamps, clips, snaps or other conventional attachment means. The skirt **26** is preferably connected to the collapsible table **10** in a manner that allows the user to remove and attach the skirt **26** quickly. The skirt **26** is preferably constructed of sheet material such as cardboard or fabric, but can be constructed of other wood products, paper, or plastic. The skirt **26** allows a user to customize the appearance of the collapsible table **10**. As can be seen in FIG. **14a**, a customizable skirt **26** preferably includes a plurality of slats or strips **27** defined by thin recesses, which allow the customizable skirt **26** to be formed around the skirt flange **46** or periphery **40.1** of the tabletop **12**. The slats also allow a user to roll up the customizable skirt **26** into a compact roll or shape when it is not in use.

[0093] To initially assemble the collapsible table **10**, the secondary shelf **16** is placed onto the legs. At this point, the stop portions **112** are not yet connected to the legs. Also, at this point, the first leg **18** is not connected to the fourth leg **24** with the first brace member **136** and the second leg **20** is not connected to the third leg **22** with the second brace member **138**. The first leg **18** slides into the first leg aperture **152** of the secondary shelf **16**. The second leg **20** slides into the second leg aperture **154** of the secondary shelf **16**. The third leg **22** slides into the third leg aperture **156** of the secondary shelf **16**. The fourth leg **24** slides into the fourth leg aperture **158** of the secondary shelf **16**. The secondary shelf **16** slides down the legs over the top portions **108** and the bottom portions **110** until the secondary shelf **16** lands onto the first support bar **132** and the second support bar **134**. When the secondary shelf **16** is resting on the support bars, the first support bar **132** slidably fits into the first support bar cutout **162** of the secondary shelf **16** and the second support bar **134** slidably fits into the second support bar cutout **164** of the secondary shelf **16**. Preferably the support bars are substantially the same size as the support bar cutouts and the support bars and support bar cutouts frictionally fit together.

[0094] After the secondary shelf **16** has been placed onto the legs and the secondary shelf **16** is resting on the support bars, the first half **128** and second half **130** of the stop portions **112** are connected to the legs. The stop portions **112** are preferably constructed of injection-molded thermoplastic and are connected to the legs with screws. The stop

portions 112 could also be connected to the legs using a number of different methods, including but not limited to screws, bolts, rivets, or other suitable connecting means. As can be seen in FIG. 4b, the stop portions 112 can be selectively placed at a desired position (e.g., position 112a or position 112b) on the legs. By doing so, the height of the first shelf 14 can be placed at a desired position (position 14a or position 14b) on the legs.

[0095] Next, the shelf 14 is placed onto the legs. The first leg 18 slides into the first leg aperture 152 of the shelf 14. The second leg 20 slides into the second leg aperture 154 of the shelf 14. The third leg 22 slides into the third leg aperture 156 of the shelf 14. The fourth leg 24 slides into the fourth leg aperture 158 of the shelf 14. The shelf 14 slides down the legs until the shelf 14 lands onto the stop portions 112. Because the shelf apertures are slightly smaller in size than the stop portions 112, the stop portions 112 hold the shelf 14 vertically in position.

[0096] The first leg 18 and the fourth leg 24 are then rigidly connected with the first brace member 136. The first brace member 136 is preferably connected to the first leg 18 and the fourth leg 24 using weldments. The second leg 20 and the third leg 22 are rigidly connected with the second brace member 138. The second brace member 138 is preferably connected to the second leg 20 and the third leg 22 using weldments. Finally, the legs and brace members are rigidly connected to the tabletop. The first brace member 136 is connected to the first channel 60 using bolts or screws. The second brace member 138 is rigidly connected to the second channel 62 using bolts or screws.

[0097] Once the collapsible table 10 is assembled, it can be used in an upright use position for using the collapsible table 10 or collapsed into a nested position for easy storage or transport. To collapse the table 10 into the nested position, the skirt 26 is removed from the skirt flange 46. Next, the table 10 is arranged so that the working surface 30 is facing downward or on the ground. The shelf 14, with the aid of gravity and the user, will fall downward and pass slide over the leg top portions 108 so that the top surface 140 of the shelf 14 lies adjacent to the tabletop underside 40. As the shelf 14 falls downward, it remains substantially parallel to the tabletop 12.

[0098] Next, the secondary shelf 16, with the aid of gravity and the user, will fall so that the top surface 140 of the secondary shelf 16 slides over the legs bottom portions 110, the stop portions 112, the top portions 108, and the top surface 140 of the secondary shelf 16 will come into contact with the bottom surface 142 of the shelf 14. As the secondary shelf 16 falls downward, it remains substantially parallel to the tabletop 12.

[0099] After that, the two legs with the shorter top portions 108, the first leg 18 and second leg 20 as depicted in the figures, are folded from the extended position to a folded position such that the top portion 108 is substantially perpendicular to the bottom portion 110. The legs will hold the shelf 14 and secondary shelf 16 into a nested position. Finally, the two legs with longer top portions 108, the third leg 22 and the fourth leg 24 as depicted in the figures, are folded from the extended position to a folded position such that the top portion 108 is substantially perpendicular to the bottom portion 110. The third leg 22 and fourth leg 24 being folded from an extended position to a folded position can be

seen in FIGS. 14-17. The table in a fully collapsed state can be seen in FIGS. 18-20. When the table 10 is in the fully collapsed state, the legs retain the shelves in a nested position.

[0100] To reverse the procedure and set the collapsible table 10 up into its use position, the third leg 22 and the fourth leg 24 are unfolded from a folded position to an extended position. Then the first leg 18 and second leg 20 are unfolded from their folded position to an extended position. The table 10 is then flipped over so that the feet 120 on the first leg 18, second leg 20, third leg 22, and fourth leg 24 are on the ground.

[0101] The secondary shelf 16 will slide down the legs over the top portions 108 and the bottom portions 110 until the secondary shelf 16 lands onto the first support bar 132 and the second support bar 134. When the secondary shelf 16 is resting on the first support bar 132 and second support bar 134, the first support bar 132 slidably fits into the first support bar cutout 162 of the secondary shelf 16 and the second support bar 134 slidably fits into the second support bar cutout 164 of the secondary shelf 16. Because the support bars are substantially the same size as the support bar cutouts, the support bars and support bars frictionally fit together.

[0102] Next, the shelf 14 slides down the legs over the top portions 108 until the shelf 14 lands onto the stop portions 112. Because the leg apertures on the shelf 14 are slightly smaller in size than the stop portions 112, the shelf is wedged onto the stop portions 112 and the stop portions 112 preclude the shelf 14 past the stop portions 112. When in the use position, the shelf 14 and the secondary shelf 16 provide the table with stability and lock the foldable legs into place. Finally, the customizable skirt 26 may be attached to the skirt flange 46 with Velcro®.

[0103] Although the table 10 according to the present invention is depicted and described comprising four legs, it is contemplated that the table could be constructed with as few as two legs. For example, the table could be constructed of two, three, five, or any other number of legs and still embody the inventive features of the present invention.

[0104] Referring to FIG. 18, the table is highly suitable for use as a display table at a trade show. As such, the invention also includes the "kit" of an enclosure such as a bag 200 along with the collapsible table 10 and skirt 26. The collapsed table and folded skirt fit with the closeable bag 200.

[0105] Referring generally to FIGS. 19-39, table 10 can include at least one accessory pole or mast 220. The accessory pole 220 is attachable to various portions of the table 10, such as the tabletop 12, or insertable through one or more of the apertures 42, 106, 160 in the table 10 to support a display device 225 such as a computer monitor 340, signage or various other appurtenances. The signage can include known graphics and displays 225 such as a display board 342 or a display screen or banner 344. With such an accessory pole 220, various appurtenances can be selectively attached to the table 10. While the accessory pole 220 is described or depicted generally in terms of its use with the collapsible table 10, implementation of the accessory pole 220 with a myriad of other tables, such as those utilized in trade show and exhibition environments, is envisioned as well.

[0106] Referring primarily to the embodiments of FIGS. 19-20, and 21-23, the at least one accessory pole or mast 220 includes an upper post member 222 and a lower post member 224. The upper post member 222 is generally tubular in shape to define an interior bore 228 extending therethrough. In one embodiment the tubular shape of the member 222 is generally oval, although other shapes and configurations are envisioned as well. In addition, the upper post member 222 can include a plurality of wire distribution apertures or slots 234 which provide access into the interior bore 228 at predefined locations along the member 222. The upper post member 222 can further include connecting apertures and/or a plurality of peripheral channels 226 extending axially along the member 222. The channels 226 are generally U-shaped and extend into the interior bore 228 of the upper post member 222 to define a plurality of interior protruding flats 230, and can take on various shapes and design configurations. The lower post member 224 in one embodiment is generally C-shaped and has a base portion 236 to define an interior region 238. In addition to the open C-shaped configuration, the lower post member 224 could take on other shapes in alternate embodiments, including a closed tubular shape similar to that of the upper post member 222. Each of the members 222, 224 can be constructed of various materials, including plastics, metals and the like.

[0107] As best shown in the embodiments of FIGS. 19-20 and 23-25, the interior bore 228 of the upper post member 222 can be configured to slidably receive the lower post member 224 to provide a telescoping interplay between the post members 222, 224. Accordingly, the generally C-shaped lower post member 224 slides into securable positioning between a plurality of the interior protruding flats 230, as demonstrated in FIG. 23. The upper post member 222 can include a plurality of interior arm members 231 as well. In such an embodiment, end portions of the generally C-shaped lower post member 224 will confront the interior arm members 231 to further promote alignment and securement of the lower post member 224 within the interior bore 228 of the upper post member 222. Other techniques and configurations for connecting the members 222, 224 in an end-to-end relationship are envisioned as well for providing the accessory pole 220 of the present invention.

[0108] At least one locking fastener 242, such as a bolt or screw, is inserted into and through at least one of the peripheral channels 226 proximate the base portion 236 to engage and secure the lower post member 224 within the upper post member 222. As shown in FIGS. 19-20, counterclockwise rotation of the at least one fastener 242 causes disengagement of the fastener 242 with the base portion 236 to permit the lower post member 224 to telescopically extend or slide out from the interior bore 228 of the upper post member 222, through the table apertures 42, 106, 160, and into a resting position at one end on the floor or ground. Upon reaching a desired telescoping length, the at least one fastener 242 can then be rotated in a clockwise direction to again engage with the base portion 236 for locking engagement. With such a telescoping configuration, the lower post member 224 can be selectively extended out from the upper post member 222 at various lengths, depending on the height of the table 10, the spacing of the shelves 14, 16, and similar considerations. In one embodiment, the upper post member 222 is sized or shaped (i.e., oval shaped) such that an end portion of the upper post member 222 abuts against the tabletop 12 to prevent the upper post member 222 from

sliding through the aperture 42. The above-described steps are simply reversed to telescopically return or retreat the lower post member 224 back into the interior bore 224 of the upper post member 222 for handling or transporting.

[0109] In other embodiments, such as those depicted in FIGS. 20a-20b, the at least one accessory pole 220 includes two or more generally parallel post members 223 adapted to receive and display appurtenances or devices 225 therebetween. In addition, the post member 223 can be connected to the tabletop at predefined spaced positions to provide separate and distinct masts 220 for displaying display devices 225. The parallel members 223 can be connected to the tabletop 12, through apertures in the tabletop 12, or in accordance with other configurations and techniques disclosed and depicted herein. As is the case with other embodiments, the parallel post member 223 embodiments can be connected to display tables of varying configurations, such as those known and the collapsible configurations provided herein. Further, any of the accessory pole 220 embodiments and corresponding components can be utilized to connect or mount other devices known to those skilled in the art, such as framing, shelves, table accessories, tubular and box framework, display hardware components, and a myriad of other known devices.

[0110] As stated, the wire distribution apertures or slots 234 provide access into the at least one accessory pole 220, or the upper post member 222, as depicted in FIGS. 24-25. In one embodiment, the apertures 234 provide access for routing and distributing wires such as computer cables, power cables, stereo component cables, and the like. The wires or cabling generally include wire ends 332 (i.e., plugs) that can be inserted into one of the apertures 234 and then fed down the member 222, and out another one of the apertures 234 or out an end of the member 222. If an end user desires to route the subject wire out the bottom of the upper post member 222 to one of the table shelves 14, 16 or to a ground/floor location, the C-shaped lower post member 224 can be utilized for wire distribution as well. While the open C-shaped lower post member 224 does not require apertures to route wires in and out of its interior 238, apertures can be included in alternate embodiments. The wires 330 and wire ends 332 can be selectively routed through the various table apertures 42, 106, 106, depending on the location of the device or outlet into which the wire ends 332 are to be plugged or connected.

[0111] Referring primarily to FIGS. 26-33, the table 10 and corresponding at least one accessory pole 220 can include a mounting assembly 246 to facilitate the attachment of various display devices 225, such as monitors and signage. As described and depicted herein, the mounting assemblies 246 generally include a horizontal extending rigid portion or member, such as brackets, rods, fasteners, bars, housing portions, display or board/banner portions and the like to facilitate connectivity between the appurtenances and the at least one accessory pole 220. In addition, mounting assemblies 246 can be mounted to various apertures in the at least one accessory pole 220. In another embodiment, the assembly 246 includes a universal mounting plate member 248, at least one plate fastener 250, at least one mounting washer 254, and at least one appurtenance mounting bracket device 252. The mounting plate member 248 includes at least one aperture 249. As depicted in FIGS. 26-27, the mounting plate member 248 receives the at least one fas-

tener 250 with the mounting washer 254 in the corresponding at least one aperture 249. In a preferred embodiment, two fasteners 250 and mounting washers 254 are included. After engaging the fasteners 250 and washers 254 to the plate member 248, the plate member 248 is slidably engaged along at least one of the plurality of peripheral channels 226 of the upper post member 222. The plate member 248, therefore, can be selectively positioned along the length of the channel 226, and secured into the desired position by tightening the fasteners 250 against the channels 226. Once the universal plate member 248 is secured in place, various appurtenance mounting brackets 252 can be attached thereto.

[0112] The appurtenance mounting bracket 252 of the mounting assembly 246 can include or be coupled to a variety of mounting assemblies, such as a literature rack mounting assembly 256, a monitor mounting assembly 258, or a display mounting assembly 260. Other like assemblies adapted to secure to the universal plate member 248 can be employed as well without deviating from the spirit and scope of the present invention. In one embodiment, the literature rack mounting assembly 256 includes a framework portion 270 and a back bracket portion 272, as shown in FIGS. 28 and 31. The framework portion 270 can further include a top receiving framework 274, a bottom receiving framework 276, a bottom seating framework 278, and a central portion 280. The back bracket portion 272 includes a back bracket body 286 and at least one attachment slot 288.

[0113] To mount the literature rack mounting assembly 256 to the universal plate member 248 positioned within one of the peripheral channels 226, the at least one attachment slot 288 is aligned with the at least one fastener 250 and slid into secure engagement thereon, as best shown in FIG. 31. In the embodiment of FIGS. 28 and 31, there are two attachment slots 288 for facilitating such engagement. Other configurations are envisioned as well. Once slid into engagement, the literature rack mounting assembly 256 can be further secured by tightening the at least one fastener 250 and the corresponding at least one washer 254 against the bracket body 286 surrounding the slot 288. Literature, such as brochures, pamphlets and the like can then be inserted within the framework portion 270 such that the literature is confined at one end by the top receiving framework 274, and at the other end by the bottom receiving framework 276 and bottom seating framework 278. Other configurations for the framework portion 270 are also envisioned to retain and display literature therein.

[0114] In another embodiment, the monitor mounting assembly 258 is attached to the universal plate member 248. This monitor mounting assembly 258 is generally designed to selectively attach monitors 340, such as computer flat-panel displays, along the at least one accessory pole 220, as shown in FIGS. 29-30 and 32-33. The monitor assembly 258 can include a mounting body portion 290, a mounting channel 292, extending mounting plates 294, mounting apertures 296 and at least one attachment slot 298. Similar to the attachment steps for the literature mounting assembly 256, the at least one attachment slot 298 of the monitor assembly 258 is aligned with the at least one fastener 250 of the plate member 248, slid into engagement thereon, and secured by tightening the at least one fastener 250 and the corresponding at least one washer 254 against the mounting body portion 290 surrounding the slot 298. Once attached,

the mounting channel 292 extends out generally transverse from the face of the upper post member 222 such that the extending mounting plates 294 are offset out from the post member 222 a desired distance to facilitate attachment of the monitor 340 to the plates 294 at the mounting apertures 296. Again, the assemblies 258 or the plate member 248 can be attached to the at least one accessory pole 220 using hardware and techniques other than the at least one peripheral channel 226.

[0115] In other embodiments, devices or signage can be attached to the accessory pole 220 using mechanisms other than the universal mounting plate member 248. For instance, in an alternate embodiment, the appurtenance mounting assembly includes a display mounting assembly 260 adapted to connect various display devices 225. These alternate display mounting assemblies 260 can include a board mounting assembly 262 and a banner mounting assembly 264. Other assemblies compatible with attachment to the at least one accessory pole 220 and/or the peripheral channels 226 are envisioned as well.

[0116] As shown in FIGS. 34-37, the board mounting assembly 262 can include a gripper device 300, a first fastener 302, a nut or bracket 304, a second fastener 306 and a graphic board or panel 312. The gripper device 300 generally includes a board receiving slot 308. For attaching the board or panel 312 to the at least one accessory pole 220 via the board mounting assembly 262, the gripper device 300 is attached to the nut or bracket 304 with the first fastener 302, such as a screw. Once interconnected, the gripper 300 and nut 304 are attached to the upper post member 222 by slidably engaging the nut 304 into and along one of the peripheral channels 226 to a desired location along the member 222. The first fastener 302 can then be further tightened to secure the gripper 300 and nut 304 in place within the channel 226. An edge portion of the board or panel 312 is then slid into the matable receiving slot 308 of the gripper device 300 as demonstrated in FIG. 36. Once slid into position, the second fastener 306, such as a set screw, is inserted generally transversely into the gripper 300 and tightened against the edge of the board 312 to secure the board 312 in place. As shown in FIG. 37, two or more of the gripper devices 300 can be implemented along desired locations of the post member 222 and board 312 to provide additional securement and connectivity options.

[0117] As shown in FIGS. 38-39, the banner mounting assembly can include a plurality of nuts or brackets 318, a plurality of banner rods 320, and a banner 324. In addition, the nuts or brackets 318 can include rod receiving apertures 319 and the banner rods 320 can include engagement threads 322. The banner rods 320 threadably engage the rod receiving apertures 319 to interconnect the rods 320 and nuts 318. Similar to the attachment steps for the board mounting assembly 262, the nuts or brackets 318 are slidably engaged into and along one of the peripheral channels 226 to a desired location along the upper post member 222, depending on the size and configuration of the corresponding banner 324. The banner 324 further includes a banner body portion 326 and distal tubular end portions 328 adapted to slide over the banner rods 320, as depicted in FIG. 39. At least one of the tubular end portions 328 can then be pull in a direction away from the other of the tubular end portions 328 to draw the banner 324 tautly in position. Once the tubular end portions 328 and corresponding banner rods 320

are in the desired positions to draw the banner taut, the banner rods **320** can be further tightened into the rod receiving apertures **319** to fully secure the components in place.

[0118] Another embodiment of the present invention is a collapsible shelf system. A collapsible shelf system preferably comprises substantially the same structure and components of the collapsible table **10**. However, the collapsible shelf system preferably comprises at least three shelves. In addition, the dimensions of the shelf system would preferably be selected so that the collapsible shelf system could be used as a shelf. In a collapsed configuration, the at least three shelves of the collapsible shelf system would preferably rest against a shelf top that is similar to the tabletop **12** of the collapsible table **10**. When the collapsible shelf system is in a use position, the at least three shelves would slide down the legs of the shelf system and rest upon a plurality of stop portions included on the legs. In certain embodiments the legs could have holes extending there through to permit adjustability and additional shelves by insertion of stop portions configured as simple as removable pins.

[0119] Another embodiment of the present invention is a collapsible podium. A collapsible podium preferably comprises substantially the same structure and components of the collapsible table **10**. However, the dimensions of the podium would preferably be selected so that the collapsible podium could be used as a podium when in a use position and collapsed into a collapsed configuration when not in use.

[0120] The present invention may be embodied in other specific forms without departing from the spirit or essential attributes thereof; and it is, therefore, desired that the present embodiment be considered in all respects as illustrative and not restrictive, reference being made to the appended claims rather than to the foregoing description to indicate the scope of the invention.

1. An display appurtenance attachment system, comprising:

a display table including a plurality of table legs and a tabletop;

at least one accessory pole being generally tubular defining an interior bore therethrough, the at least one accessory pole supported by and extending above the tabletop and further including at least one outer peripheral channel extending axially therealong; and

a mounting member slidably engageable within the at least one outer peripheral channel of the at least one accessory pole to mountably receive an appurtenance such that the mounting member and the appurtenance are selectively positionable along a length of the at least one accessory pole a distance above the tabletop.

2. The attachment system of claim 1, wherein the at least one accessory pole includes two generally parallel accessory poles supported by the tabletop and adapted to receive the appurtenance therebetween.

3. The attachment system of claim 1, wherein the at least one accessory pole includes an upper post member and a lower post member such that the lower post member is receivable into and extendable out from the upper post member in a telescoping relationship.

4. The attachment system of claim 3, wherein the upper post member has a generally oval-shaped cross section.

5. The attachment system of claim 1, wherein the at least one accessory pole includes at least one wire distribution aperture providing access into the interior bore to facilitate routing of wiring through the at least one accessory pole.

6. The attachment system of claim 3, wherein the upper post member further includes at least one locking aperture within the at least one peripheral channel providing communication through to the interior bore such that the at least one fastener is threadably engageable within the locking aperture to engage a base portion of the lower post member to secure the lower post member.

7. The attachment system of claim 3, wherein the table further includes at least one shelf positioned below the tabletop, the at least one shelf having a shelf aperture extending therethrough to receive the lower post member.

8. The attachment system of claim 1, further including at least one appurtenance fastener attachable to the mounting member to mountably receive the at least one appurtenance.

9. The attachment system of claim 8, wherein the at least one appurtenance is a literature mounting assembly having at least one attachment slot to slidably secure the literature mounting assembly to the at least one appurtenance fastener, and a framework portion adapted to receive and surrounding retain literature therein for display.

10. The attachment system of claim 8, wherein the at least one appurtenance is a monitor mounting assembly having a body portion and an extending mounting plate, the body portion having at least one attachment slot to slidably secure the monitor mounting assembly to the at least one appurtenance fastener such that the extending mounting plate extends generally transversely from the body portion to securely receive a display monitor.

11. The attachment system of claim 10, wherein the display monitor is a flat-panel computer monitor.

12. The attachment system of claim 8, wherein the at least one appurtenance is a display board assembly having a gripper device with a board receiving slot and being securable to the appurtenance fastener, a board fastener, and a graphic display board having an edge portion, wherein the edge portion is slidably receivable within the board receiving slot and secured in place by engagement of the board fastener against the edge portion.

13. The attachment system of claim 1, further including a banner mounting assembly including at least one banner rod having a threaded end portion, and a banner having at least one tubular end portion, the at least one banner rod being generally transversely securable to the mounting bracket member by threadable attachment of the threaded end portion to the mounting bracket member, the at least one tubular end portion being slidably securable over the at least one banner rod for displaying the banner adjacent to the at least one accessory pole.

14. The attachment system of claim 1, wherein the display table is collapsible such that the plurality of legs are foldable and attachable to a bottom side of the tabletop, the collapsible display table further including a shelf attachable to the foldable legs and movable upwardly and downwardly along the foldable legs.

15. An appurtenance attachment assembly and in combination with a collapsible display table, comprising:

a collapsible display table including a tabletop, at least one shelf and a plurality of foldable legs attachable to a bottom side of the tabletop, the tabletop including an attachment aperture extending through the tabletop,

and the at least one shelf being attachable to the foldable legs and movable upwardly and downwardly along the foldable legs;

an adjustable accessory mast assembly including an upper post member and a lower post member, the upper post member being generally tubular defining an interior bore therethrough, the lower post member adapted for telescoping extension from and insertion into the interior bore of the upper post member and being insertable through the at least one attachment aperture of the tabletop, wherein the upper post member further includes a plurality of outer peripheral longitudinal channels; and

a bracket member slidably engageable within at least one of the plurality of outer peripheral channels to mountably receive at least one appurtenance device.

16. The appurtenance attachment assembly of claim 15, wherein the at least one appurtenance device includes means for securing the appurtenance device to the bracket member.

17. The appurtenance attachment assembly of claim 16, wherein the appurtenance device is selected from a group consisting of: a literature rack, a computer monitor, a graphic board, and a display banner.

18. A table display system for attaching and displaying accessories, comprising:

a display table including a plurality of table legs, and a tabletop;

mast means for operably attaching and displaying a display device above the table; and

mounting means for coupling the at least one display device to a portion of the mast means above the display table.

19. The table display system of claim 18, wherein the plurality of legs are foldable and attachable to a bottom surface of the tabletop to make the display table a collapsible display table.

20. The table display system of claim 18, wherein the mast means includes an upper post member and a telescoping lower post member, the upper post member being generally tubular to define an interior bore therethrough, the lower post member adapted for telescoping extension from and insertion into the interior bore of the upper post member, wherein the upper post member further includes a plurality of outer peripheral longitudinal channels to facilitate the mounting means.

21. The table display system of claim 20, wherein the mounting means includes a bracket member slidably insertable within the outer peripheral longitudinal channels and securable to the at least one display device to facilitate attachment of the at least one display device to the mast means.

22. The table display system of claim 18, wherein the mounting means includes a mounting assembly selected from a group consisting of: a literature rack mounting assembly, a computer monitor mounting assembly, a graphics board mounting assembly, and a display banner mounting assembly.

23. The table display system of claim 18, wherein the mast means further includes aperture means therein for distributing wires therethrough.

24. A method of displaying appurtenances on a display table, comprising:

providing a display table having a plurality of table legs, a tabletop and an attachment aperture extending through the tabletop;

providing at least one adjustable accessory pole having an upper post member and a lower post member, the upper post member being generally tubular defining an interior bore therethrough and sized larger than the cross sectional dimension of the lower post member such that the lower post member is receivable within the interior bore, the upper post member further having a plurality of peripheral channels extending axially therealong;

telescopingly extending the lower post member out from the interior bore of the upper post member a distance sufficient to insert a portion of the lower post member through the attachment aperture of the tabletop;

sliding the extended portion of the lower post member through the attachment aperture until the extended portion reaches a stop position;

engaging a locking fastener through the upper post member to a portion of the lower post member within the interior bore to secure the upper and lower post members in place;

slidably engaging a mounting bracket along one of the plurality of peripheral channels; and

operably mounting a display device to the upper post member with the mounting bracket such that the display device is mounted adjacent to the upper post member a distance above the tabletop.

25. The method of claim 24, wherein mounting a display device includes mounting a mounting assembly selected from a group consisting of: a literature rack mounting assembly, a computer monitor mounting assembly, a graphics board mounting assembly, and a display banner mounting assembly.

26. The method of claim 24, wherein providing a display table includes providing a collapsible table such that the plurality of legs are foldable and attachable to a bottom side of the tabletop, the collapsible display table further including a shelf attachable to the foldable legs and movable upwardly and downwardly along the foldable legs.

27. A table display system, comprising:

a collapsible display table including a plurality of foldable table legs foldably attachable to a bottom surface of the tabletop;

at least one accessory pole being generally tubular defining an interior bore therethrough, the at least one accessory pole supported by the tabletop; and

a generally rigid mounting member connectable to the at least one accessory pole to extend generally horizontally therefrom and to mountably receive a display device such that the mounting member and the display device are positionable along a length of the at least one accessory pole a distance above the tabletop.

28. The table display system of claim 27, wherein the at least one accessory pole includes two generally parallel accessory poles supported by the tabletop and adapted to mountingly receive the display device therebetween.

29. The table display system of claim 27, wherein the at least one accessory pole includes an upper post member and a lower post member such that the lower post member is

receivable into and extendable out from the upper post member in a telescoping relationship.

30. The table display system of claim 29, wherein the upper post member includes at least one peripheral longitudinal channel adapted to mountably receive the generally rigid mounting member.

31. The table display system of claim 27, wherein the at least one accessory pole includes at least one wire distribution aperture providing access into the interior bore to facilitate routing of wiring through the at least one accessory pole.

32. The table display system of claim 27, wherein the generally rigid mounting member includes a mounting assembly selected from a group consisting of: a literature

rack mounting assembly, a computer monitor mounting assembly, a graphics board mounting assembly, and a display banner mounting assembly.

33. The table display system of claim 27, wherein the display device is selected from a group consisting of: a literature rack, a computer monitor, a graphic board, and a display banner.

34. The table display system of claim 27, wherein the collapsible display table further includes a shelf attachable to the foldable legs and movable upwardly and downwardly along the foldable legs.

* * * * *