

G. H. BABCOCK & S. WILCOX.
 Steam and Vapor-Engines.

No. 133,742.

Patented Dec. 10, 1872.

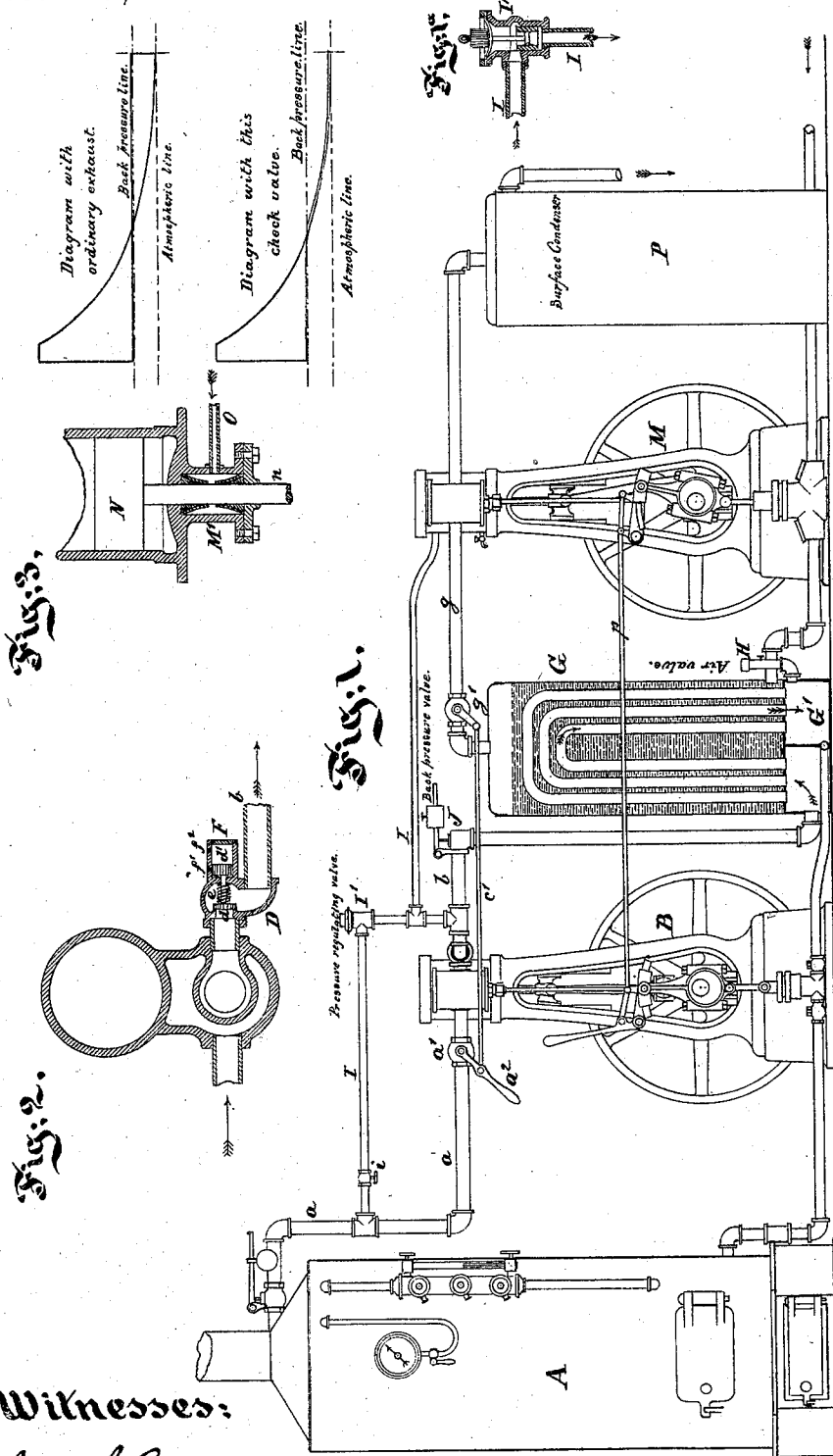

Witnesses:

Arnold Hornum.
W. C. Day

Inventors:
 Geo. H. Babcock
 and Stephen Wilcox
 by their attorney, J. B. Weston

UNITED STATES PATENT OFFICE.

GEORGE H. BABCOCK, OF PLAINFIELD, NEW JERSEY, AND STEPHEN WILCOX, OF BROOKLYN, NEW YORK.

IMPROVEMENT IN STEAM AND VAPOR ENGINES.

Specification forming part of Letters Patent No. 133,742, dated December 10, 1872.

To all whom it may concern:

Be it known that we, GEORGE H. BABCOCK, of Plainfield, Union county, in the State of New Jersey, and STEPHEN WILCOX, of Brooklyn, Kings county, in the State of New York, have invented certain Improvements relating to Compound Steam and Vapor Engines, of which the following is a specification:

We utilize the heat remaining in the exhaust steam after its work in the steam-engine by causing it to vaporize sulphuric ether or some analogous volatile fluid, and use such vapor in a separate engine in a manner analogous to what is known as the Du Trembley engine. We have invented important improvements in the details, which promote economy in the construction and operation, and overcome some of the practical difficulties heretofore experienced in this class of engines. Instead of exhausting the steam into a condenser maintained at or below the pressure of the atmosphere, we exhaust it into a condenser exposing so little surface and holding the volatile fluid at so high a temperature that the pressure of steam in the condenser is maintained above the atmospheric pressure. The loss of power in the steam apparatus due to the back pressure thus induced is more than counterbalanced by the increased efficiency of a given amount of surface in the evaporating-vessel and by the increased pressure of the volatile vapor available, and the water of condensation is returned to the steam-boiler at a higher temperature. We introduce a peculiar check-valve in the exhaust-pipe close to the valve-chest of the steam-engine, which quietly and effectually prevents a back flow of steam from the exhaust-pipe into the cylinder under any conditions. We employ self-acting air-valves to discharge, when any appreciable quantity of air can be collected adjacent to them, from the steam in the evaporator or from the vapor in the vapor-condenser. We connect and combine the starting-valves from the steam-engine and vapor-engine so that both are started and stopped, or more or less throttled, simultaneously. We connect and combine the expansion-gear or cut-off mechanisms of the two engines so that when the degree of expansion in the steam-engine is changed the corresponding mechanism in the vapor-engine

will be correspondingly changed. We employ peculiar packings in the stuffing-boxes of the vapor-engine, and produce a constant high pressure of oil or other fluid between them, so as to better insure against a loss of the vapor. We provide for admitting steam directly from the steam-boiler to the evaporator or vapor-manufacturing vessel so that on commencing to work the apparatus the vapor-engine starts under full pressure, with all the parts properly heated; and in combination therewith we provide a self-closing valve in such heating-pipe, so that the steam pressure thus induced in the evaporator will never exceed a certain desired limit, however high may be the boiler pressure.

The following is a description of what we consider the best means of carrying out the invention.

The accompanying drawing forms a part of this specification.

Figure 1 is a general view of the entire apparatus, the evaporator being in section and the other parts in elevation. Figs. 2 and 3 are sections representing certain detached portions. Fig. 2 is a horizontal section through the steam-cylinder and the parts immediately adjacent, showing the check-valve in the exhaust-passage. Fig. 3 is a vertical section of the lower end of the vapor-cylinder, showing the stuffing-box and provisions for insuring against the loss of vapor.

Similar letters of reference indicate like parts in all the figures.

A is a steam-boiler of any ordinary or suitable construction. B is a steam-engine, and M a vapor-engine. Each engine is equipped with a variable cut-off. G is the evaporator, a strong vessel analogous to a boiler, in which the heat is transmitted from the exhaust-steam to the volatile fluid to form vapor for the vapor-engine. G' is the chamber in which the water accumulates, as also whatever air may be in the steam. P is a surface-condenser, in which the vapor is condensed by a liberal supply of cold water applied through the medium of tubes, as will be readily understood. The water constantly pumped from the base of the evaporator G into the boiler A is worked off in the form of steam through the engine B, and in being condensed again into water im-

parts heat to the liquid ether in the evaporator G. The ethereal vapor thus produced is worked off through the engine M and condensed again into a liquid vapor in the condenser P, and pumped back in the liquid form into the base of the evaporator G. We maintain the evaporator at so high a temperature as only to reduce the pressure of the steam to about two atmospheres—that is to say, to fifteen pounds above the pressure of the atmosphere. This may seem to be a disadvantage, in so far as the power of the steam-engine B is concerned; but it allows a great economy in the cost and bulk of the apparatus and gives a more than proportionate increase in the power of the vapor-engine M. H is a self-acting air-valve, connected with the evaporator G, as shown. The details of the construction of this valve need not be shown, as they may be similar to air-valves or air-traps which have been employed in other situations. It contains a valve provided with metallic attachments sensitive to heat, so that so long as steam is present in the casing or chamber G' the valve H will remain closed, but so soon as a sufficient quantity of air gathers in the chamber G' to exclude the steam the temperature is reduced, and the contraction of the metallic connections opens the valve and causes it to discharge until the air is expelled and steam follows it, again heating the metal. The steam-pipe *a*, which conducts the steam from the boiler A to the steam-cylinder B, has a throttle-valve, *a*¹, which is provided with an operating-lever, *a*², and connected by a rod, *c*¹, to a throttle-valve, *g*¹, which is fitted in the vapor-pipe *g* and controls the flow of vapor from the evaporator G to the vapor-engine M, and thus ultimately to the surface-condenser P.

In starting the engine, after having the parts properly warmed, the handle *a*² alone is operated, and on opening the valve *a*¹, either fully or to a small extent, the other valve *g*¹ is correspondingly opened, and the same in closing. This provision insures a proper supply of fluid to both engines in starting, and also that the supply is simultaneously cut off in stopping the engines.

We have represented both the engines B and M as provided with the latest improved cut-off gear. Other cut-off mechanisms may be substituted with some success; but we attach great importance to the connection of the mechanisms of the two engines by means of the rod *p*. This rod connects the cut-off or expansion-gear of the steam-engine B with the corresponding part of the vapor-engine M, so that any change in the degree of expansion in one engine is accompanied by a corresponding change in the degree of expansion of the other engine. This provision renders it impossible for any extraordinary variations of pressure to obtain in the evaporator G. In its absence the apparatus, worked under varying conditions, would be

liable to accumulate an extraordinary pressure of volatile vapor, when the steam is suddenly allowed to follow the piston further in the steam-engine, by reason of the increased quantity of steam thrown into the evaporator without any corresponding increase in the quantity of vapor taken away. It not only insures against a too high pressure in the evaporator G, but equally guards against the opposite condition, which would otherwise be liable to obtain should the vapor-engine continue to consume vapor at the same rate as before after the steam-engine had reduced its supply of steam. Under this latter condition the high degree of vacuum which might be induced in the evaporator would lower the pressure of the vapor below a practical or useful tension, and on a resumption of full-power conditions again the mass of metal in the evaporator would require some time to become warmed by the steam before the vapor-engine would be properly working. Our connection of the throttle-valves *a*¹ and *g*¹ insures proper adjustment in the starting, and our connection of the cut-off mechanisms insures proper adjustment under all conditions of the running of the engines.

Referring to Fig. 3, N is the piston, and *n* the piston-rod operating in the vapor-engine M. The stuffing-box M' surrounding the piston-rod *n* is constructed with a liberal depth, as shown, and incloses two leathers pressed up into the form known as cup-leathers, and fixed in reversed positions, as shown. Oil is supplied through the pipe O from a small pump or other apparatus, not represented, which maintains a constant pressure on the oil above the highest which is ever allowed to obtain in the vapor-cylinder. It follows that the stuffing-box M' is constantly filled with oil, which by its pressure is endeavoring to force itself past the lower cup-leather, and thus escape from the apparatus altogether, and also past the upper cup-leather into the interior of the vapor-cylinder. The cup-leathers being properly fitted little oil will be thus discharged; but it will be obvious that under these conditions no vapor can escape from the cylinder, for however much the cup-leathers may leak, they will only leak oil, which may be recovered again by proper means, and the vapor will never escape from the interior of the cylinder into and past the stuffing-box, in which a higher pressure is maintained. Other fluids than oil may be used, if preferred, and other suitable material similarly formed into cups or cones may be used instead of leather to form what we have termed the cup-leathers.

Referring to Fig. 2, it will be seen that the construction provides a casing, D, close to the valve-chest, in which is mounted a puppet-valve, *d*, moving horizontally, and connected by a stem to a piston, *d*¹, playing in an approximately closely fitting cylinder, F, in which there are two small orifices, *f*¹ *f*². The valve *d* with the connected piston *d*¹ is subject to the action of the spring *e*, which tends to hold

the valve *d* closed. The force of this spring is gentle, and the valve *d* is easily opened by the current of the exhaust steam while it flows out of the cylinder; but when, in consequence of the employment of a high degree of expansion, there is, on the opening of the exhaust-passage, a tendency to a backward movement of the steam from the exhaust-pipe *b*, the valve *d* is closed by the action of the spring *e*, and the piston is allowed to move backward without any increased resistance. The effect is exhibited in the two diagrams represented on the right-hand side of the figure, in which the uppermost shows the action under ordinary conditions when the steam is allowed to flow backward freely from the exhaust-pipe, and the lowermost shows the action with this check-valve. Under ordinary conditions the opening of the exhaust-valve after a high degree of expansion has been reached causes an increase in the pressure in front of the piston on the return-stroke, by allowing the steam to return from the entire exhaust-pipe. Under the action of this check-valve *d* only the very small amount of steam between the check-valve *d* and the cylinder is allowed to expand backward. The piston *d'* performs an important function in avoiding or softening concussions of the check-valve. When a blast of exhaust steam strikes the valve it would be liable to be thrown open too far and to strike with great force, except that air is cushioned in the cylinder *F* in front of the piston *d'*. When at the end of the stroke the check-valve *d* shuts, the violence of its shutting is arrested by the cushioning of a small quantity of air on the other face of the piston *d'*. Thus the air is alternately drawn in and forced out through the orifices *f*¹ and *f*², which insures a gentle movement of the valve *d* at and near each end of its motion, while it is allowed to move rapidly in the middle of its motion.

Referring again to Fig. 1, *i* is a screw-valve in a pipe, *I*, branched and connected, as represented, so as to perform two important functions. It connects through one branch to the exhaust-pipe *b*, and through another branch to a casing around the cylinder of the vapor-engine *M*.

To warm the vapor apparatus, previous to starting the engineer opens the valve *i*, and steam thereupon flows directly into the exhaust-pipe *b* and warms the evaporator *G*, and also flows into the space around the cylinder of the vapor-engine, so as to warm it. This insures not only the warming of the vapor-engine *M*, but also the generation of a due pressure in the evaporator *G*, so that both engines may start with a proper amount of power. After starting the engines the valve *i* may be closed, and thenceforward the pipe *I* with its branches will perform the function only of allowing steam to flow from the exhaust-pipe *b* into the space around the cylinder of the vapor-engine *M*.

It is easy to see that if the full pressure of steam upon the boiler is, during the preliminary warming, admitted to the evaporator *G*, and this pressure of steam is allowed to obtain therein for any considerable period, mischief is liable to be produced by the generation of too high pressure of the vapor, which, while the employment of a safety-valve on the vapor apparatus would reduce the danger of explosion, would be productive of much loss of valuable material. We provide against all this by introducing into the pipe *I* a pressure-regulating valve, *I'*, which is so commonly known in gas and other apparatus as to require no minute description. It is a delicately-mounted valve, which will allow the steam to flow past it freely until the pressure in the exhaust-pipe *b* and its connections is raised to a certain predetermined point. When this pressure is attained in the exhaust-pipe *b*, and consequently in the bent pipes in the evaporator *G*, the regulating-valve *I'* closes, and only opens again when the steam in the connections is so far condensed as to call for more steam to maintain the desired pressure. However widely the hand-valve *i* is unscrewed, the pressure-regulating valve *I'* takes care of the pressure, so that the steam pressure from this source never rises above the proper point in the evaporator *G* and its connections.

Fig. 1^a represents in section one of the forms in which this self-regulating valve may be constructed.

Safety-valves, pressure-gages, oil-cups, and other ordinary or suitable appliances, not represented, may be employed at various points. We have represented a safety-valve, *J*, at a point in the exhaust-pipe *b*, which may be important under certain circumstances.

It will be understood that the steam-engine *B* and vapor-engine *M* may be both connected by belts or gearing to a single shaft, so that both shall run at the same speed, or so that one may run in any desired ratio to the other.

What we claim as our invention is as follows:

1. In a motor in which power is first derived from steam and secondly from the vapor of ether or analogous volatile fluid, produced by the heat of the exhaust steam, we claim, the said exhaust steam maintained at a pressure above that of the atmosphere, and at a consequently high temperature, and worked through a cut-off mechanism connected to the cut-off mechanism of the vapor-engine, as and for the purposes herein specified.

2. In combination with a compound steam and vapor engine, we claim the automatic air valve or trap *H*, connected to the chamber *G'* of the evaporator *G*, as and for the purposes herein specified.

3. In combination with the vapor-engine *M*, we claim a stuffing-box having two cup-leathers arranged opposite to each other and subject to the action of a fluid having a high-

er pressure than the maximum obtaining in the cylinder, all substantially as herein specified.

4. We claim the check-valve *d*, in combination with retarding means for preventing violent concussion, all arranged relatively to the exhaust-pipe *b* and to the valve-chest of a steam or analogous engine, as and for the purposes herein specified.

5. In combination with a steam-engine, B, vapor-engine M, and provisions *I* *i* for admitting steam at will from the boiler A to the

evaporator G, we claim the pressure-regulating valve *I'*, arranged, as shown, so as to limit the pressure in the evaporator G, as and for the purposes herein set forth.

In testimony whereof we have hereunto set our hands this 15th day of July, 1872, in the presence of two subscribing witnesses.

GEO. H. BABCOCK.
STEPHEN WILCOX.

Witnesses:

W. C. DEY,
ARNOLD HÖRMANN.