

(19) **DANMARK**



Patent- og
Varemærkestyrelsen

(10) **DK/EP 2704982 T3**

(12) **Oversættelse af
europæisk patentskrift**

-
- (51) Int.Cl.: **B 67 D 1/12 (2006.01)** **B 67 D 1/08 (2006.01)**
- (45) Oversættelsen bekendtgjort den: **2016-12-19**
- (80) Dato for Den Europæiske Patentmyndigheds bekendtgørelse om meddelelse af patentet: **2016-08-24**
- (86) Europæisk ansøgning nr.: **12729336.3**
- (86) Europæisk indleveringsdag: **2012-04-27**
- (87) Den europæiske ansøgnings publiceringsdag: **2014-03-12**
- (86) International ansøgning nr.: **BE2012000020**
- (87) Internationalt publikationsnr.: **WO2012149612**
- (30) Prioritet: **2011-05-02 BE 201100261**
- (84) Designerede stater: **AL AT BE BG CH CY CZ DE DK EE ES FI FR GB GR HR HU IE IS IT LI LT LU LV MC MK MT NL NO PL PT RO RS SE SI SK SM TR**
- (73) Patenthaver: **Dispac-Projects NV, Admiraalhof 24, 9070 Destelbergen, Belgien**
- (72) Opfinder: **WAUTERS, Albert, Marie, Admiraalhof 24, B-9070 Destelbergen, Belgien**
- (74) Fuldmægtig i Danmark: **Chas. Hude A/S, H.C. Andersens Boulevard 33, 1780 København V, Danmark**
- (54) Benævnelse: **Fastgørelse af en fitting på en beholder**
- (56) Fremdragne publikationer:
WO-A1-01/12537
WO-A2-2008/098936
AT-B- 250 748
GB-A- 2 246 768
US-A- 3 005 573
US-A- 3 116 747
US-A- 3 361 152
US-A- 4 102 167
US-A- 4 717 048
US-A- 5 544 779
US-A- 5 673 934
US-B1- 6 286 702
US-B1- 6 471 082

DESCRIPTION

[0001] The present invention relates to an assembly for fixing a fitting on a container, typically a beer container. The invention further relates to a container on which such an assembly is mounted and a use of a fitting body in such an assembly.

[0002] EP0225035 A2 in the name of Johnson Enterprises describes a fitting for a beer container or the like. The fitting has a fitting body which is fixed on the neck of a bottle using a coupling ring 55 and a retaining ring 70. Coupling ring 55 is provided at the bottom with slots for the purpose of forming flexible tongues which can engage over a neck ring. Retaining ring 70 is slid over coupling ring 55 to lock the fitting firmly onto the neck.

[0003] US 4,717,048 discloses a fitting 18 for a keg 16. The keg 16 is provided with a top wall 17 with an opening. A neck 20 of the fitting 18 is fixed in the opening of the top wall 17, see figure 1. There is provided a tap 15 for dispensing beer or other beverage from the keg 16. The tap is provided with an expandable and contractible camming collar 50 which is formed by a pair of clamps 51 and 52. Figure 11 shows the collar 50 in the open stand (the tap is in a released position relative to the fitting). A perspective view of the clamps 51, 52 is shown in figure 10. When the clamps 51, 52 are closed, lugs 54 cam beneath an outwardly protruding lip 45 on the neck 20 to move wall 24 of the valve from the ball seat 22 downward, whilst at the same time locking the tap 15 on the neck. The clamps 51, 52 are made of plastic.

[0004] The present invention has for its object to provide an improved assembly for fixing a fitting on the neck of a container, with which a compact, easy to mount assembly is obtained which allows a firm fixing of a fitting on a container.

[0005] The present invention further relates to the use of a fitting in such an assembly.

[0006] The assembly according to the invention is distinguished for this purpose in that the assembly comprises a fitting body provided with a support flange adapted to support on the neck; and at least two ring sections which can be attached to each other to form a ring round the neck of the container. The assembly is intended for co-action with a neck with a thickened neck portion. The at least two ring sections are adapted to extend around the neck of the container and over the fitting body. Provided on an inner side thereof is a protruding part intended to engage under the thickened neck portion.

[0007] A good retention of the fitting body on a neck of the container is in this way obtained using simple ring sections which can be attached to each other to form a ring. Attachment of the ring sections in a lateral plane is all that is necessary here, and no components need engage resilient parts on the neck of the bottle. Retaining rings and the like are thus not required.

[0008] According to an advantageous embodiment, the assembly comprises two ring sections extending through about 180 degrees around the neck. Variants with for instance three ring sections, each extending through about 120 degrees round the neck, can also be envisaged.

[0009] According to a simple embodiment, each ring section of the at least two ring sections is provided on its inner wall with a ring segment moulded thereon for the purpose of forming the protruding part which engages under a thickened neck portion, typically a neck ring. This ensures in suitable manner that the ring sections cannot slide off the neck.

[0010] According to an advantageous embodiment, the neck is provided with a number of protrusions and the fitting body is provided with a number of protrusion receiving parts in which the number of protrusions can be received. Such protrusions allow non-rotating positioning of the fitting body on the neck of the container. The protrusions are preferably arranged on a neck ring formed integrally with the neck, but can also be provided directly on the neck. The protrusion receiving parts are preferably formed on the fitting body in the form of downward protruding flanges with a recess having a shape complementary to the shape of the protrusions.

[0011] According to an advantageous embodiment, each ring section of the at least two ring sections is provided with a first connecting part and with a second connecting part. The first connecting part of each ring section of the at least two ring sections is adapted to co-act, preferably via a snap connection, with the second connecting part of an adjacent ring section of the at least two ring sections for mutual attachment of the at least two ring sections. According to a possible embodiment hereof, each first connecting part of each ring section comprises a resilient locking arm protruding outward from an outer end of this ring section. Each second connecting part of an adjacent ring section then comprises a recess in which the locking arm can be locked. Such a locking arm is preferably provided with a protruding part formed to engage behind a wall of the recess for the purpose of locking the locking arm in the recess.

[0012] According to a preferred embodiment, the second connecting part is identical to the first connecting part of each ring section. Each connecting part then has a resilient locking arm protruding outward from an outer end of this ring section and a recess in which the locking arm of an adjacent ring section can be locked. A double locking can in this way be obtained between adjacent ring sections, and the two or more ring sections can take an identical form.

[0013] According to a further aspect of the invention, the fitting body is provided along its periphery with a profiling and the at least two ring sections are provided with a complementary profiling for non-rotating positioning of the at least two ring sections relative to a fitting placed on the neck of the container. According to an advantageous embodiment hereof, the fitting body has a substantially cylindrical upright jacket part and the profiling is provided on this jacket part. The ring sections can then have an upper part with a cylindrical inner wall provided with the complementary profiling.

[0014] According to yet another aspect of the invention, the fitting body for each ring section is provided with an upward protruding part, and each ring section is provided at the outer ends thereof with a recess with a shape adapted to receive the upward protruding parts. Each upward protruding part can in this way be received in mutually connecting recesses of adjacent ring sections. This will allow non-rotating positioning of the at least two ring sections on the fitting body.

[0015] The invention further relates to a container on which an assembly according to any of the above described embodiments is mounted. The container has a neck provided with at least one thickened neck portion extending substantially along the periphery of the neck, typically a neck ring which is formed integrally with the neck and under which extends the protruding part of the at least two ring sections. The container and the assembly are preferably adapted to store a liquid under a pressure lying between 0.25 bar and 10.00 bar, preferably between 0.50 bar and 3.50 bar. Although the container according to the invention is particularly intended to store carbonated liquids under pressure - envisage a beer container - such a container can advantageously also be employed to store gases and solid substances.

[0016] The invention also relates to a use of a fitting body in an assembly according to any of the above described embodiments. Such a fitting body can particularly be embodied with one or more of the above described measures thereof.

[0017] Advantageous embodiments are described in the dependent claims.

Brief description of the drawings:

[0018]

figure 1 is a schematic perspective view of a first embodiment according to the invention of a fitting body and a ring section which are arranged on a neck of a container; figure 2A is a schematic cross-section of a second embodiment of an assembly according to the invention, wherein the cross-section is taken through the plane in which a first ring section connects to a second ring section;

figure 2B is a detail view of the cross-section of figure 2A;

figure 2C is a view corresponding to the view of figure 2B, but in the opened position of the valve;

figures 3A and 3B illustrate a schematic perspective view of mutually attached ring sections according to an embodiment of the invention, as seen from respectively the upper side and from the underside;

figures 4A and 4B show a schematic perspective view of the one ring section of figure 3A as seen from respectively the upper side and from the underside;

figures 5A and 5B show a schematic perspective view of an embodiment of a fitting body seen from respectively the upper side and from the underside;

figure 6 shows a schematic perspective view of a suction tube mounting piece of the embodiment of figure 2A;

figure 7 shows a schematic perspective view of a part of the suction tube of the embodiment of figure 2A;

figure 8 shows a schematic perspective view of the valve components of the embodiment of figure 2A;

figure 8A shows a cross-sectional detail view thereof; figures 9A and 9B show a perspective view of the cap of the embodiment of figure 2A, as seen from respectively the upper side and from the underside;

figures 10A and 10B show an alternative embodiment of the cap of the embodiment of figure 2A, as seen from respectively the upper side and from the underside;

figure 11 shows a perspective view of a spring assembly according to the invention;

figure 12A shows a top view of a disc spring and

figure 12B shows a front view of the disc spring of figure 12A;

figure 13 is a schematic perspective cross-sectional view of a first embodiment of a pressure relief valve.

figure 14 is a schematic cross-section of the pressure relief valve of figure 1;

figure 15 is a schematic cross-section of the pressure relief valve of figure 1 in the buckled position;

figure 16 shows respectively a schematic perspective view and a cross-section of a possible housing for a pressure relief

figures 17A and 17B illustrate a possible arrangement of the housing of figure 16 in the embodiment of the fitting assembly illustrated on the basis of figures 1-10;

figures 18 and 19 illustrate two other possible embodiments of a pressure relief valve ;

figure 20 illustrates a cross-section of an embodiment of a pressure relief valve mounted in a suction tube;

figure 21 illustrates a cross-section of an embodiment of a pressure relief valve mounted in a suction tube; and

figures 22A and 22B show respectively a cross-section and a perspective view of an embodiment of a pressure relief valve mounted in a suction tube.

[0019] Figure 1 illustrates an assembly which is partially mounted on a container 100 of plastic, only the neck 101 of which is shown in figure 1. The neck is provided with two thickened neck portions, here in the form of neck rings 102, 103 formed integrally with neck 101 of container 100, extending along the periphery of the neck. Container 100 is typically manufactured by blow moulding, particularly by stretch blow moulding, preferably from one of the following materials: a PET material, in particular bottle grade PET, a PP material, a PE material or a PEN material. This latter is typically used for reusable containers. The skilled person will appreciate that the invention is equally applicable to so-called one-way containers as to reusable containers. Container 100 is typically adapted to store a liquid under a pressure lying between 0.25 bar and 10.00 bar, preferably between 0.50 bar and 3.50 bar. According to an advantageous embodiment, the container is embodied as described in BE 2010/0302 in the name of applicant.

[0020] The assembly comprises a fitting body 104 and two ring sections 106a, 106b, of which only one ring section is shown in figure 1. The skilled person will appreciate that more than two ring sections can also be provided, wherein it is the intention that these two or more ring sections form a ring around neck 101.

[0021] Fitting body 104 is intended for the purpose of receiving different fitting components which make it possible for instance to supply a gas while liquid is being discharged from the container, as is shown in figure 2C. In figure 2A the following fitting components can be distinguished: a cap 131, a sealing ring 132 for the seal between fitting body 104 and neck 101, a suction tube 133, 134 for drawing the fluid into container 100, a suction tube mounting piece 135, a spring 136 for exerting a spring action against valve components 137 and 139, a pressure relief valve 138, valve components 137 and 139 and a seal 140 between pressure relief valve 138 and suction tube piece 133. This is only an example, and the skilled person will appreciate that the fitting can also be constructed in other manner.

[0022] Fitting body 104 is provided with a support flange 105 adapted to support on neck 101. The two ring sections 106a, 106b can be attached to each other so as to form a ring, as shown best in figures 3A and 3B and 4. Each ring section 106a, 106b is adapted to extend over fitting body 104, as best seen in figure 1 which shows that ring section 106a extends partially over support flange 105 of fitting body 104. On an inner side of each ring section 106a, 106b is a protruding part in the form of a ring segment 110 (see figures 2 and 3) intended to engage under neck ring 102. Note that it would also be possible to make ring sections 106a, 106b higher, wherein ring segments 110 could then engage under the lower neck ring 103. The skilled person will further appreciate that, instead of a continuous ring segment, one or more protruding parts can also be provided distributed along the periphery which are adapted to engage under a neck ring. As a result of the fact that ring sections 106a, 106b engage on the one hand under a neck ring and extend on the other over the fitting body, ring sections 106a, 106b will, after being attached to

each other, hold fitting body 104 fixedly on neck 101 of the container. Ring sections 106a, 106b can for instance be manufactured from a PET material.

[0023] As best shown in figure 1, neck 101 is provided with a number of protrusions 120 and fitting body 104 is provided with a number of protrusion receiving parts 121 in which one protrusion 120 at a time can be received. Provided in the shown example are four protrusions distributed at regular intervals along the periphery, but there can be more or fewer protrusions which may or may not be distributed at regular intervals. Fitting body 104 can in this way be placed non-rotatably on neck 101 of container 100. Protrusions 120 are arranged on neck ring 102, but could for instance also be provided directly on the outer or upper wall of the neck. The protrusion receiving parts 121 are manufactured integrally with the fitting body in the form of downward protruding flanges with a recess having a shape complementary to the shape of protrusions 120.

[0024] Each ring section 106a, 106b is provided with a first connecting part 111 and with a second connecting part 112, as shown best in figure 1 and figures 4A and 4B. First connecting part 111 of ring section 106a, 106b is adapted to co-act with second connecting part 112 of ring section 106b, 106a for mutual attachment of the at least two ring sections. First connecting part 111 is adapted for connecting with a snap connection to second connecting part 112. In the illustrated variant the second connecting part 112 is identical to the first connecting part 111. First connecting part 111 of ring section 106a comprises a resilient locking arm 113a protruding outward from an outer end of ring section 106a and a recess 114a in which locking arm 113b of ring section 106b can be locked. Locking arm 113a can be received in similar manner in a recess 114b of ring section 106b, see figures 4A and 4B.

[0025] Fitting body 104 is further provided along its periphery with a profiling 124, see figure 5A, and the two ring sections 106a, 106b are provided with a complementary profiling 115 for non-rotating positioning of ring sections 106a, 106b relative to a fitting 104 placed on the container. Fitting body 104 has a substantially cylindrical or prismatic upright jacket part 123 and in the shown embodiment the profiling 124 is provided on this jacket part. Other variants in which the profiling is for instance provided on the upper side of support flange 105 can also be envisaged. Fitting body 104 can also be provided with a number of recesses for co-action with hook-like elements on the outer ends of the ring sections such that a first ring section 106a can be snapped onto the fitting and held fixedly thereon, after which the second ring section 106b can be placed. In the shown variant jacket part 123 is provided with recesses 129 distributed at regular intervals over the periphery. A protrusion 130 is situated on either side of each recess. Each ring section is provided at each outer end thereof with a hook-like element 116a, 116b, see figure 3A. These hook-like elements 116a,b extend behind protrusions 130 and fix a ring section to fitting body 104. They further provide in simple manner for a correct positioning on fitting body 104. An additional rotation locking between ring sections on the one hand and fitting body on the other is also achieved.

[0026] The above illustrated embodiment is intended for co-action with a container coupling of the so-called A or G-type. The container coupling is the component which is mounted on the upper side of the fitting and will allow fluid, typically beer, to flow out of the container while gas flows in so as to keep the container pressurized. In addition to the A and G-container couplings, there are also container couplings of the S, D, U and M type. The fitting will be embodied somewhat differently for these types, although the skilled person will appreciate that the invention is equally applicable to such fittings.

[0027] An embodiment of the method will now be explained for the embodiment of figures 1-5. For the purpose of mounting fitting body 104 on neck 101 of a container 100 the following steps are performed:

- the fitting body is placed on the neck, wherein receiving parts 121 are positioned over protrusions 120;
- ring section 106a is placed round the upper end of neck 101 over fitting body 104, with ring segment 110 under neck ring 102, wherein the protruding parts 116a are positioned in recesses 129;
- ring section 106b is arranged diametrically opposite ring section 106a, wherein ring section 106b is attached to ring section 106a by means of a snap connection 111, 112.

[0028] Figure 6 illustrates in detail the suction tube mounting piece 135. This piece is provided with a central opening 500 in which the suction tube part 133 illustrated in figure 7 can be fixed, as is shown best in figure 2A. The suction tube mounting piece is further provided at its periphery with receiving parts 502 for tongues 127 of fitting body 104. The downward directed tongues 127 are provided on the underside of fitting body 104 and are each provided with a hole 128 in which a protruding part 501 provided in receiving part 502 can engage in each case. The suction tube mounting piece 135 can in this way be locked in fitting body 104 on the underside thereof. The suction tube component 133 is provided with openings 504 for passage of fluid from the container, for instance beer, as illustrated schematically with arrow B in figure 2C.

[0029] Figures 8 and 8A illustrate valve components 137, 139 in detail. The annular valve component 139 is typically manufactured from a hard plastic, while the annular valve component 137 is manufactured from a soft plastic such as rubber. Valve component 139 is provided on its underside with a number of peripheral tongues 601. Valve component 137 of rubber is provided with a downward protruding inner edge 602 which extends over the whole inner periphery thereof. Tongues 601 allow a good positioning of spring 136.

[0030] Figures 9A and 9B illustrate a first embodiment variant of cap 131. Figures 10A and 10B illustrate an alternative embodiment of cap 131'. These caps 131, 131' are typically fixed against the upper side of the fitting by for instance welding or adhesion. The skilled person will appreciate that this cap can be modified in accordance with the desired container coupling.

[0031] Figure 11 shows an embodiment of a spring assembly 301 with a number of disc springs 302. Such a spring assembly can be used particularly in the fitting illustrated in figures 2A and 2B instead of spiral spring 136. Disc spring 302 is shown in more detail in figures 12A and 12B. Disc spring 302 has a substantially conical disc body 304 manufactured from plastic, typically a PET material. The skilled person will however appreciate that all food-grade plastics, such as polyethylene (PE), polypropylene (PP) etc., can in principle be used to manufacture the disc springs suitable for use in beverage containers such as beer containers. Depending on the chosen material, the embodiment will then possibly have to be modified to some extent to the mechanical properties of the chosen plastic.

[0032] The substantially conical disc body 304 is provided with a number of recesses 303 for passage of a fluid and has an upper edge 306 and a lower edge 305 in order to facilitate stacking of disc springs 302. Depending on the desired dimensions and resilience, disc springs 302 can be connected in series or in parallel or a spring assembly can be formed by a combination of series and parallel connections. Recesses 330 have the further advantage that the weight of the disc springs can be reduced.

[0033] Figure 13 illustrates an advantageous embodiment of a pressure relief valve for sealing a space under pressure. The pressure relief valve comprises a valve body 202 and a membrane 201. The valve body and the membrane are formed integrally from a plastic material, for instance a PET material. The skilled person will appreciate that all food-grade plastics, such as PE, PP, etc., can in principle also be employed for the pressure relief valve. Barrier additives can further be added to the plastic material in order to reduce the permeability thereof to for instance oxygen and nitrogen. The embodiment can be modified to some extent subject to the mechanical properties of the plastic used.

[0034] Membrane 201 extends from valve body 202 in the direction of a space R under pressure, for instance the interior of a container under pressure, to a lowest point 203. This could also be a bottom surface, for instance a small circular surface. Such a design will ensure that the membrane will in the first instance buckle and then split apart (tear) when the pressure is higher than a determined critical pressure in the space R under pressure. Figure 15 shows the membrane in the buckled position.

[0035] Membrane 201 comprises a substantially conical part 204 with a top 203 and a radius R. Other shapes, such as a pyramid shape, a truncated pyramid or truncated cone shape and the like, are also possible. According to an advantageous embodiment, the thickness D of the substantially conical part 204 decreases to some extent in the direction of top 203, as best shown in figure 14 where the thickness varies from D2 to D1. The conical part connects to a substantially cylindrical part 205 with a height H which connects to valve body 202. The thickness of this cylindrical part typically also increases gradually from D2 to the thickness of a wall of the valve body. Conical part 204 has an angle of opening α lying typically between 5 and 45 degrees.

[0036] The membrane can be provided with a number of grooves, for instance four grooves 206. The depth of each groove of the number of grooves is preferably less than half the minimal thickness of the valve body. Providing such preferably radially directed grooves 206 will improve the certainty of tearing. These grooves are typically formed integrally with the membrane. Use can be made for this purpose of specific injection moulding techniques, such as compression-injection moulding.

[0037] Valve body 202 comprises a substantially cylindrical part 207 and a clamping ring 208. Clamping ring 208 is intended to be clampingly received in a tubular piece, typically a suction tube of a fitting of a container such as a beer container. Depending on the application in which the valve is used, this clamping ring 208 can be omitted or clamping body 202 can be provided with differently formed parts for connection to the space under pressure for sealing. The substantially cylindrical part 207 has a lower end connecting to membrane 201.

[0038] Referring to figure 2A it is noted that pressure relief valve 138, which is provided in the shown embodiment at the top of the suction tube, could also be provided at one or more other locations. A number of pressure relief valves could for instance be provided against a wall of fitting body 104, for instance at the lower end thereof, wherein a suitable connection then has to be arranged in neck 101 of container 100.

[0039] Such an embodiment is illustrated in figures 16, 17A and 17B. Figure 16 illustrates a housing 401 in which a pressure relief valve 201, 202 is received using a sealing ring 406. Housing 401 has a cylindrical receiving part 402 in which the pressure relief valve 201, 202 can be received. Body 401 further has an upright part 402 which leads to an outlet pipe 404 which can be mounted in a wall of the container, for instance in the neck of a container as illustrated in figures 17A and 17B. A seal, for instance a conical seal 405, can be provided between the neck wall and outlet pipe 404. Referring to figure 17B, one or more assemblies 400 can then be arranged in the container prior to placing of the fitting body, wherein the outlet pipe is mounted in the neck wall with interposing of the conical seal. Fitting body 104 can then be placed. Fitting body 104 is advantageously provided with vertical, downward protruding ribs 407 (see also figure 5B), wherein upright part 402 can be received between the vertical ribs. These ribs 407 thus provide for a further retention and positioning of assembly 400.

[0040] Measurements have demonstrated that the parameters of the membrane illustrated in figure 14 influence P_{crit} . More specifically, P_{crit} decreases as:

- the thickness D becomes smaller;
- the angle α becomes larger;
- the radius R becomes larger;
- the height H becomes greater.

Suitably formed grooves do not affect P_{crit} but do increase the ability to break after creation of the instability and the buckling resulting from this instability. The skilled person will appreciate that parameters D , α , R and H can be optimized in accordance with the desired P_{crit} and the desired dimensions of the valve.

[0041] Figure 18 shows a variant of a pressure relief valve with a membrane 1201 which has a substantially rectangular periphery at its upper end, see the drawing on the left in figure 18. The membrane can then have a prismatic instead of a cylindrical upper part. Note that another, substantially polygonal base or an oval base and the like is also possible. The membrane can once again be embodied with a thickness which increases gradually from top 1203 to the prismatic upper part 1205. Finally, figure 19 illustrates yet another variant in which membrane 2201 ends at the bottom in a surface 2203 instead of a point.

[0042] Figures 20 and 21 illustrate two other embodiments of pressure relief valves intended for mounting in a suction tube of a container for a fluid under pressure, typically a beer container. The container and fitting can for instance be embodied as has been described above, but can also take a different form. The pressure relief valve 138 is mounted in an upper end of the suction tube 133 for drawing the fluid into the container. Suction tube 133 is provided with openings 504 for passage of fluid from the container, and pressure relief valve 138 is arranged above openings 504. The upper end of the suction tube is closed by a closing cap 149 with a hole 141 through which fluid can escape when pressure relief valve 138 opens.

In the variant of figures 20 and 21 the pressure relief valve 138 comprises a clamping block 142 which is received in sealing manner in hole 141 of the closing cap. Hole 141 and clamping block 142 take a form such that the clamping block can be pressed out of closing cap 149 from the inside of the suction tube. Clamping block 142 can for instance be conical or pyramid-shaped. In the variant of figures 20 and 21 the pressure relief valve 138 further comprises a spring support 144 and a spring means 143. Clamping block 142 is connected to spring support 144 and spring 143 acts between spring support 144 and closing cap 149 such that, when the pressure in the container exceeds a critical value, spring support 144 presses clamping block 142 outward counter to the action of spring 143. Spring support 144 is preferably an integrally manufactured piece with a base 145 and a connecting shaft 146 which is directed upward from the base and mounted on or in the clamping block. The clamping block can for instance be provided with a recess 147 into which the outer end 148 of connecting shaft 146 can be pressed.

The shape of the recess and the outer end are such that the connecting shaft is fixed in the clamping block. In the illustrated embodiment the connection between the clamping block and the connecting shaft is a dovetail connection, although the skilled person will appreciate that other connections are also possible.

[0043] In the variant of figure 20 the clamping block is manufactured from a plastic material which is more compressible than the plastic material from which the spring support is manufactured, and the material of the clamping block itself provides the sealing. The clamping block is then for instance manufactured from an EPDM (ethylene propylene diene monomer) material or an NBR (nitrile butadiene rubber) material.

[0044] In the variant of figure 21 the clamping block and the spring support can be manufactured from the same material and a sealing ring 160 is arranged around the clamping block. Both spring support 144 and clamping block 142 can for instance be manufactured in this case from a PET material.

[0045] Figures 22A and 22B illustrate yet another embodiment of pressure relief valve 138. In this embodiment the pressure

relief valve comprises a housing 150 which is mounted via a sealing ring 151 in an upper end of the suction tube. The housing is provided at the bottom with a lower opening 153 and at the top with an upper opening 154. A valve component 152 is mounted resiliently in the housing by means of a spring 155. Valve component 152 has a base part 156 adapted to close the lower opening 153 and a shaft part 157 which is directed upward from base part 156 and around which spring 155 is provided. Spring 155 acts between base part 156 and an upper wall 158 of housing 150. It will in this way be possible to press base part 156 inward counter to the spring action of spring 155 when the pressure in the container exceeds a determined critical value, whereby fluid can escape from the container through lower opening 153 and via upper openings 154 and hole 141.

REFERENCES CITED IN THE DESCRIPTION

This list of references cited by the applicant is for the reader's convenience only. It does not form part of the European patent document. Even though great care has been taken in compiling the references, errors or omissions cannot be excluded and the EPO disclaims all liability in this regard.

Patent documents cited in the description

- [EP0225035A2 \[0002\]](#)
- [US4747048A \[0003\]](#)
- [BE20100302 \[0019\]](#)

Patentkrav

1. Arrangement til fastgørelse af en fitting på en plastbeholder med en hals (101), som har mindst en fortykket halsdel (102), der i hovedsagen strækker sig langs halsens periferi, **kendetegnet ved, at** arrangementet omfatter:

et fitting-legeme (104), som har en bæreflange (105), der er indrettet til at kunne bæres på halsen (101);

- mindst to ringsektioner (106a, 106b), som kan fastgøres til hinanden, så at der dannes en ring, hvilke mindst to ringsektioner er indrettet til at strække sig omkring halsen (101) på beholderen og over fitting-legemet (104), og på en inderside heraf har en udragende del (110), som er beregnet til at kunne ligge an under halsdelen (102), som er fortykket.

2. Arrangement ifølge krav 1, **kendetegnet ved, at** hver ringsektion (106a, 106b) blandt de mindst to ringsektioner er forsynet med et ringsegment (10), som er støbt herpå med det formål at danne en udragende del.

3. Arrangement ifølge krav 1 eller 2, **kendetegnet ved, at** fitting-legemet er forsynet med et antal dele (121) til optagelse af udragende dele, og hvori et antal fremspring fra halsen (101) kan optages, så at fitting-legemet kan anbringes ikke-drejeligt på beholderens hals.

4. Arrangement ifølge ethvert af de foregående krav, **kendetegnet ved, at** hver ringsektion blandt de mindst to ringsektioner er forsynet med en første forbindelsesdel (111) og med en anden forbindelsesdel (112), og hvor den første forbindelsesdel på hver ringsektion blandt de mindst to ringsektioner er indrettet til at kunne samvirke med den anden forbindelsesdel på den ved siden af anbragte ringsektion blandt de mindst to ringsektioner – og dette med henblik på indbyrdes fastgørelse af de to ringsektioner.

5. Arrangement ifølge krav 4, **kendetegnet ved, at** den første forbindelsesdel på hver ringsektion blandt de mindst to ringsektioner er indrettet til – ved hjælp

af en snapforbindelse – at kunne fastgøres til den anden forbindelsesdel på den nærliggende ringsektion blandt de mindst to ringsektioner.

6. Arrangement ifølge krav 4, **kendetegnet ved, at** den første forbindelsesdel (111) på hver ringsektion blandt de mindst to ringsektioner omfatter en eftergivelig låsearm, som rager ud fra en ydre ende af nævnte ringsektion, og at hver anden forbindelsesdel (112) på en nærliggende ringsektion blandt de mindst to ringsektioner har en udtagning, hvori låsearmen kan låses.
- 10 7. Arrangement ifølge ethvert af kravene 4-6, **kendetegnet ved, at** den anden forbindelsesdel er identisk med den første forbindelsesdel på hver ringsektion og omfatter en eftergivelig låsearm, som rager ud fra en ydre ende af denne ringsektion, og en udtagning, hvori låsearmen på en nærliggende ringsektion kan låses.
- 15
8. Arrangement ifølge ethvert af de foregående krav, **kendetegnet ved, at** fitting-legemet langs sin periferi er forsynet med en profilering (124), og at de mindst to ringsektioner er forsynet med en komplementær profilering (115) til ikke-drejelig positionering af de mindst to ringsektioner i forhold til en fitting, som er anbragt på beholderens hals.
- 20
9. Arrangement ifølge krav 8, **kendetegnet ved, at** fitting-legemet har en i hovedsagen cylindrisk, opadrettet kappedel (123), hvor profileringen er tilvejebragt på denne kappedel, og at én eller hver ringsektion blandt de mindst to ringsektioner har en øvre del med en cylindrisk indervæg, som er forsynet med komplementær profilering.
- 25
10. Arrangement ifølge ethvert af de foregående krav, **kendetegnet ved, at** én eller hver ringsektion blandt de mindst to ringsektioner i det enkelte tilfælde ved deres ydre ender er forsynet med et krog lignende organ (116a, 116b), og at fitting-legemet langs sin ydre periferi er forsynet med et fremspring (130) for hvert krog lignende organ – og dette, så at hver ringsektion individuelt kan monteres på fitting-legemet.
- 30

11. Arrangement ifølge ethvert af de foregående krav, **kendetegnet ved, at** fitting-legemet (104) for hver ringsektion blandt de mindst to ringsektioner er forsynet med en opdragende del, og at hver ringsektion ved sine ydre ender er
- 5 forsynet med en udtagning, så at den opdragende del kan optages i nærliggende udtagninger på ved siden af anbragte ringsektioner blandt de mindst to ringsektioner – og at dette således muliggør positionering af de mindst to ringsektioner på fitting-legemet.
- 10 12. Arrangement ifølge ethvert af de foregående krav, **kendetegnet ved, at** fitting-legemet er fremstillet i polyethylen-terephthalat (PET), polyethylen (PE) eller polypropylen (PP); og/eller at de mindst to ringsektioner er fremstillet i polyethylen-terephthalat (PET), polyethylen (PE) eller polypropylen (PP).
- 15 13. Beholder, hvorpå et arrangement ifølge ethvert af de foregående krav er monteret, og hvor beholderen har en hals, som er forsynet med mindst en fortykket halsdel, som strækker sig i hovedsagen langs periferien af halsen, og hvorunder den udragende del af de mindst to ringsektioner strækker sig, og hvor den fortykkede halsdel er en halsring (102), som er udformet ud i ét med
- 20 halsen, og hvor en bæreflange (105) på fitting-legemet (104) er båret på halsringen (102), og den udragende del (110) på hver ringsektion ligger an under halsringen (102).
14. Beholder ifølge krav 13, **kendetegnet ved, at** beholderen er fremstillet ved
- 25 blæsestøbning, især ved stræk-blæsestøbning, fortrinsvis i et af følgende materialer: et PET-materiale, særligt et PET-materiale i flaskekvalitet, et PP-materiale, et PE-materiale, et PEN-materiale, og at beholderen og arrangementet fortrinsvis er indrettet til at kunne rumme en væske under et tryk mellem 0,25 bar og 10,00 bar, fortrinsvis mellem 0,50 bar og 3,50 bar.
- 30 15. Anvendelse af et fitting-legeme i et arrangement ifølge ethvert af kravene 1-12, hvilket fitting-legeme (104) er forsynet med en bæreflange, som er indrettet til at kunne bæres på halsen af en beholder.

DRAWINGS

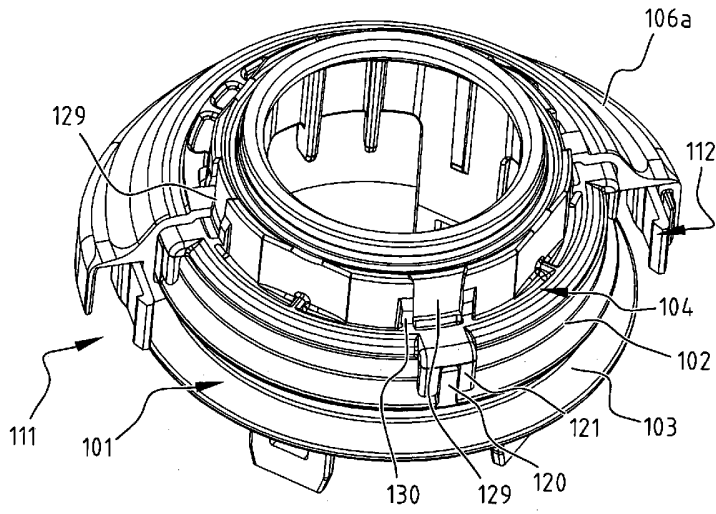

FIG. 1

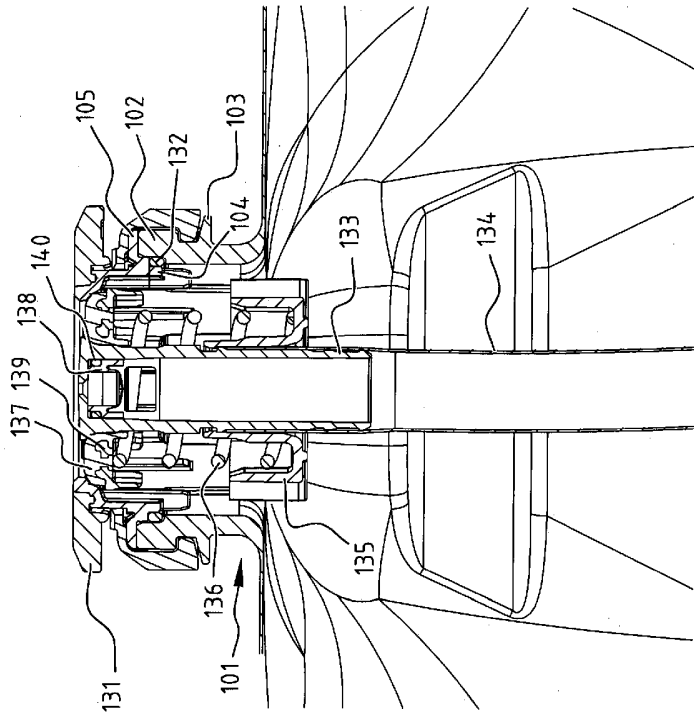

FIG. 2A

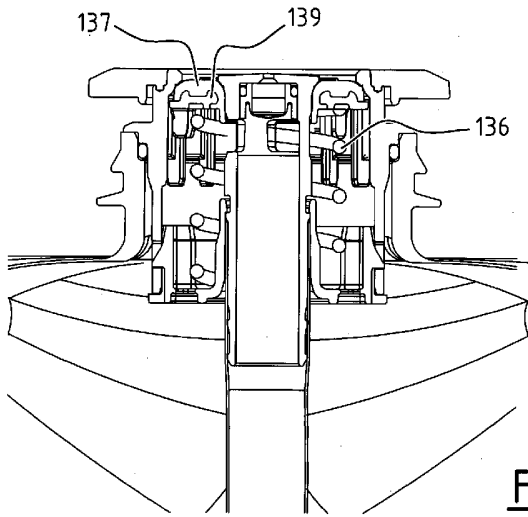

FIG. 2B

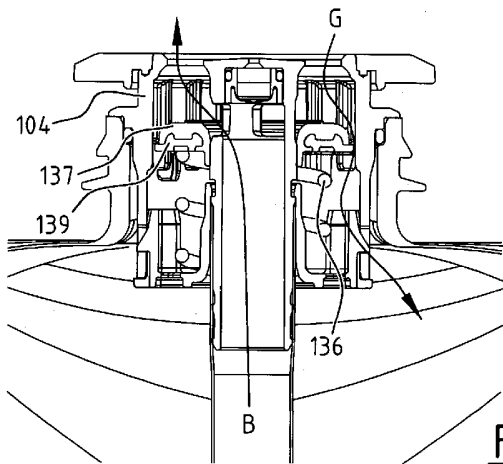

FIG. 2C

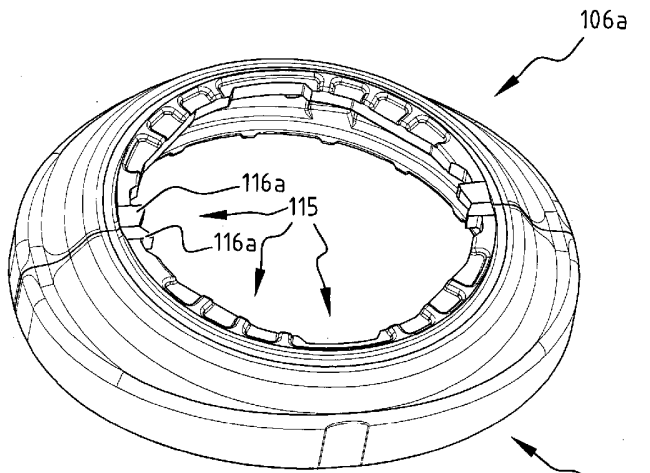

FIG. 3A

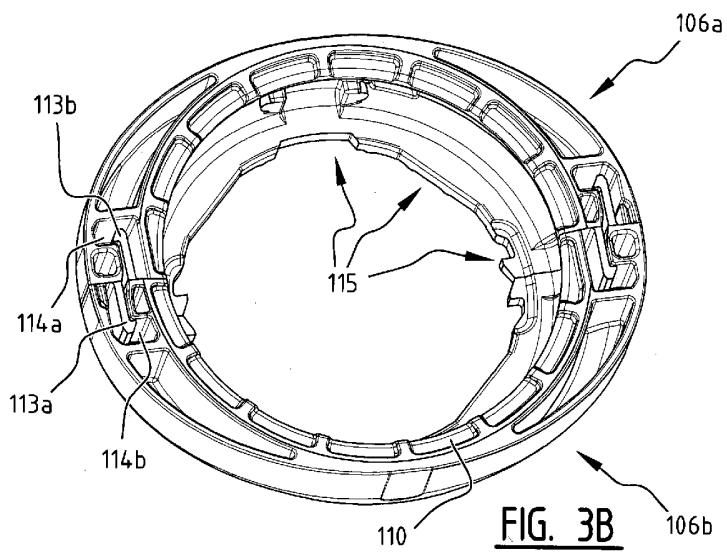

FIG. 3B

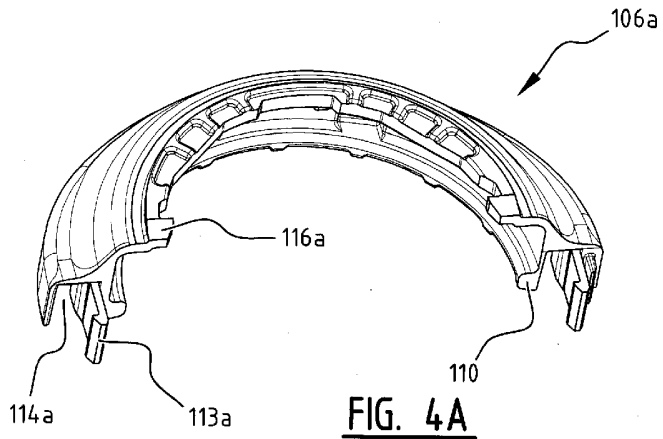

FIG. 4A

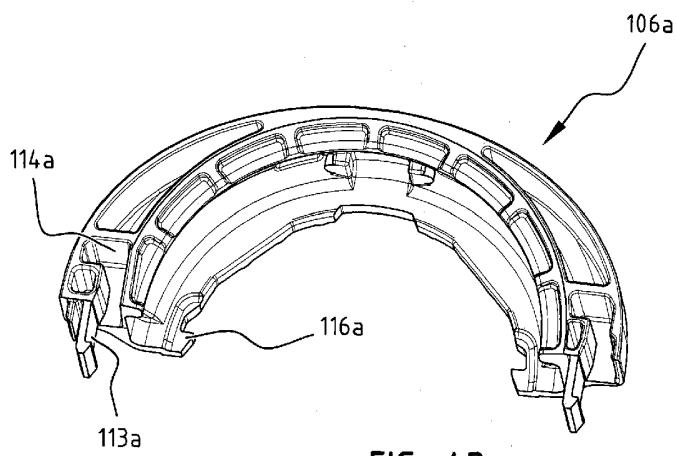

FIG. 4B

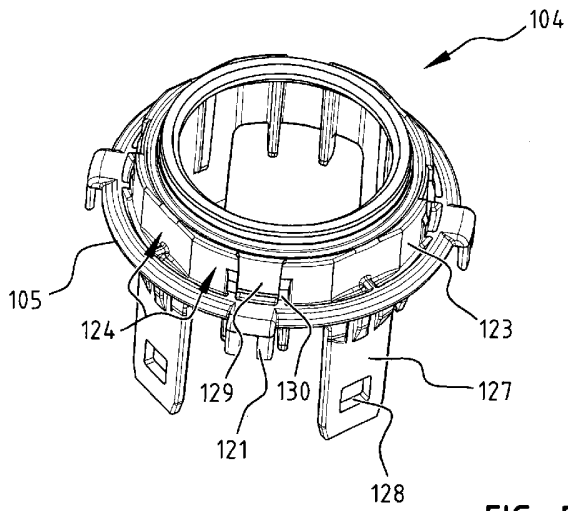

FIG. 5A

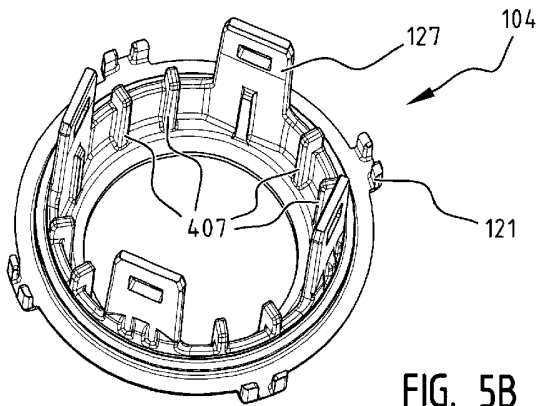
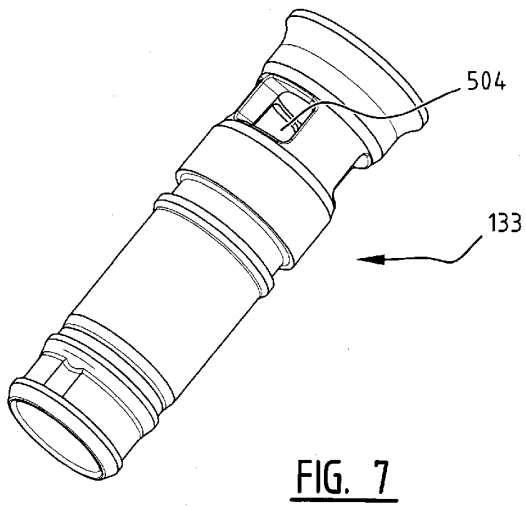
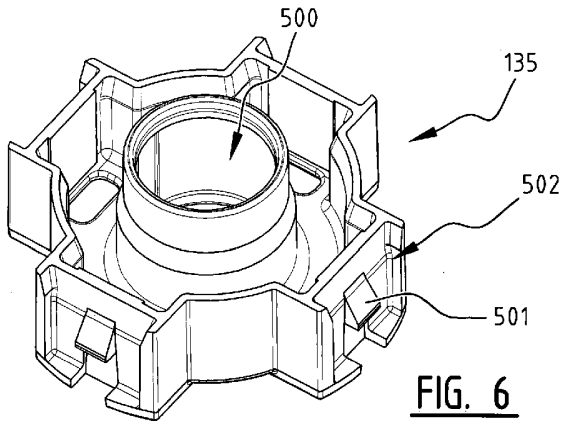

FIG. 5B



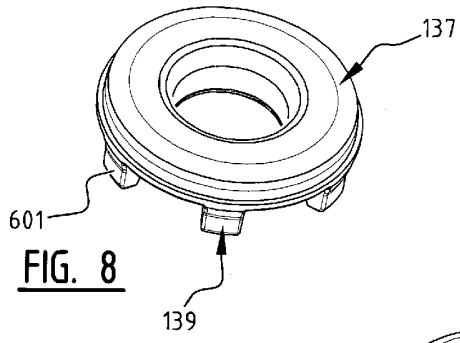

FIG. 8

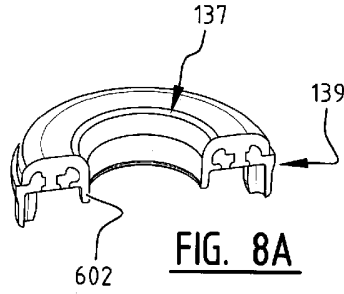

FIG. 8A

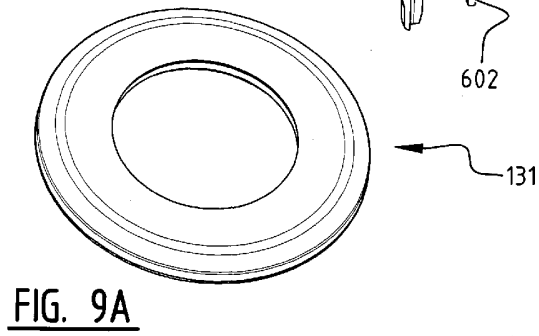

FIG. 9A

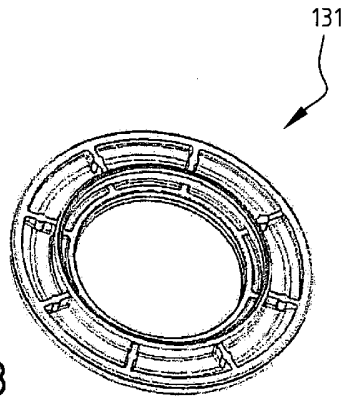
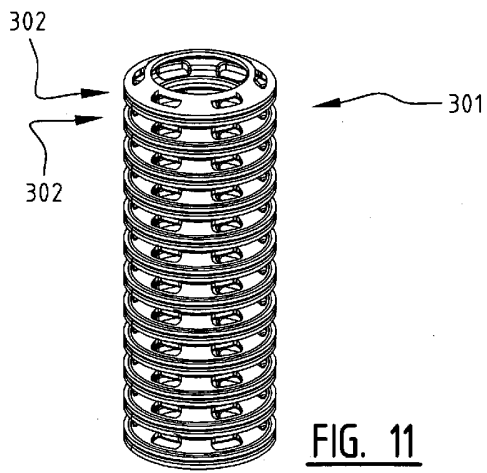
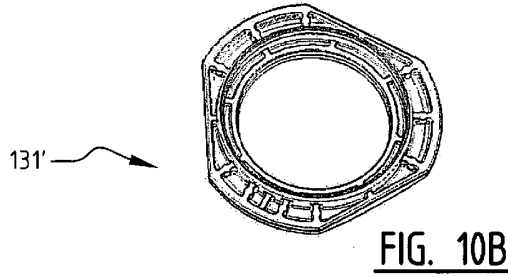
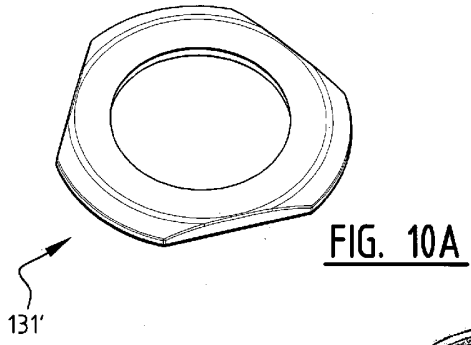
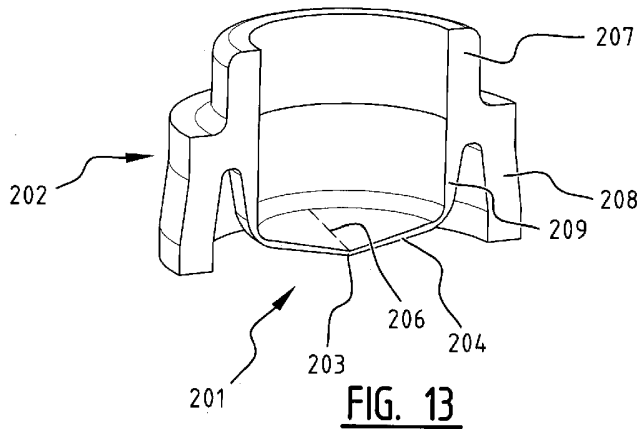
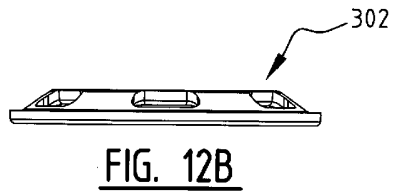
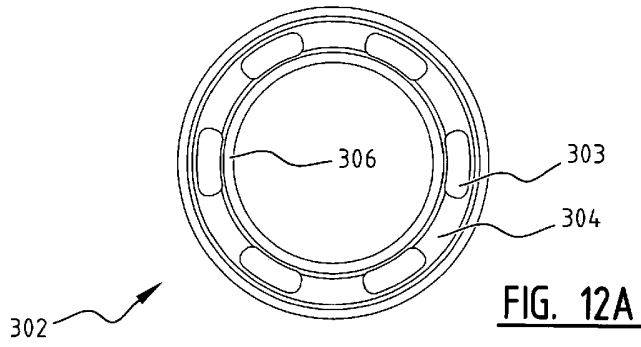

FIG. 9B





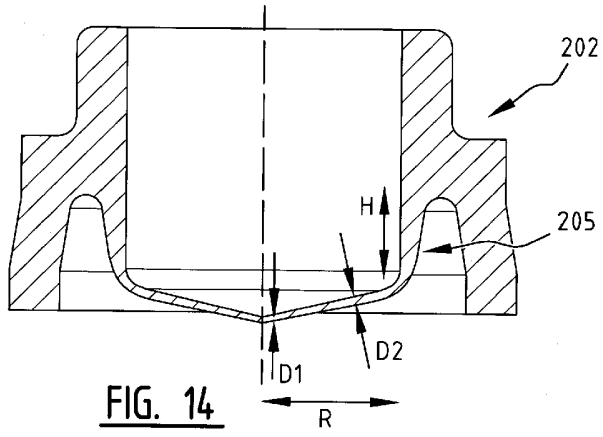

FIG. 14

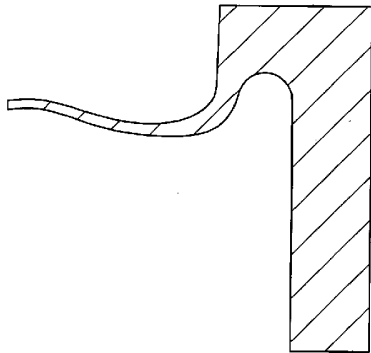

FIG. 15

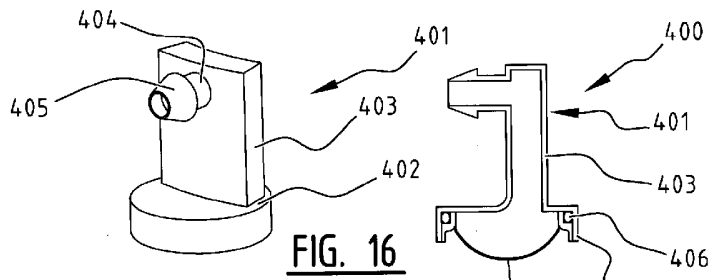

FIG. 16

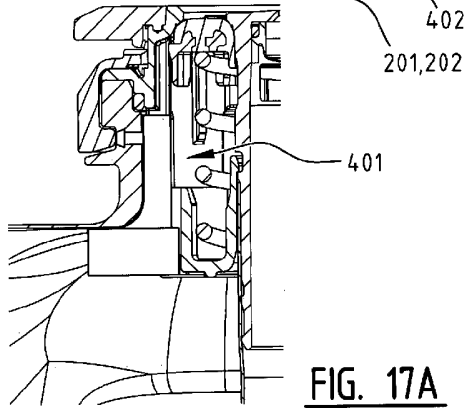

FIG. 17A

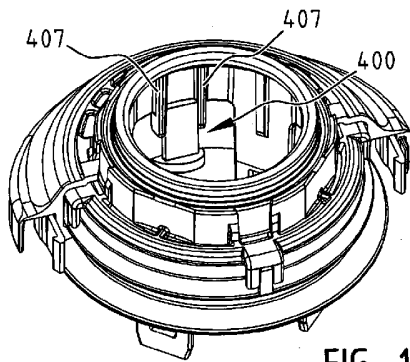
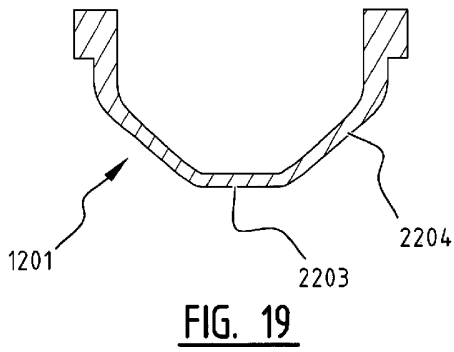
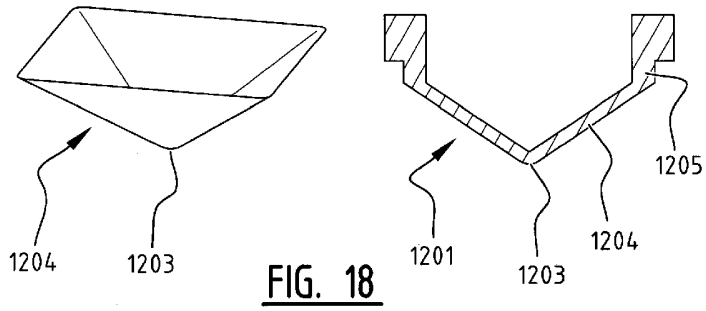

FIG. 17B



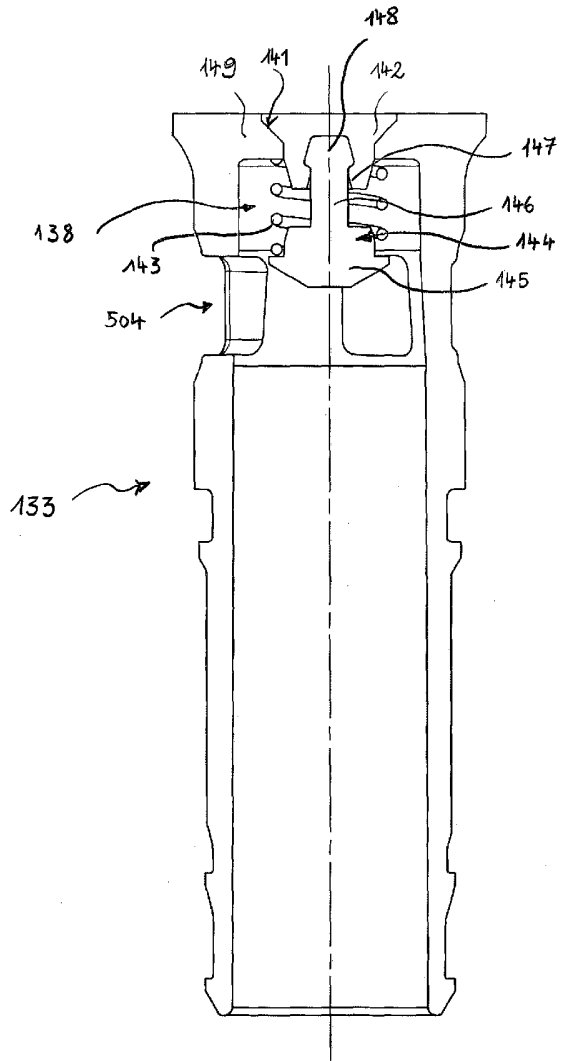

FIG. 20

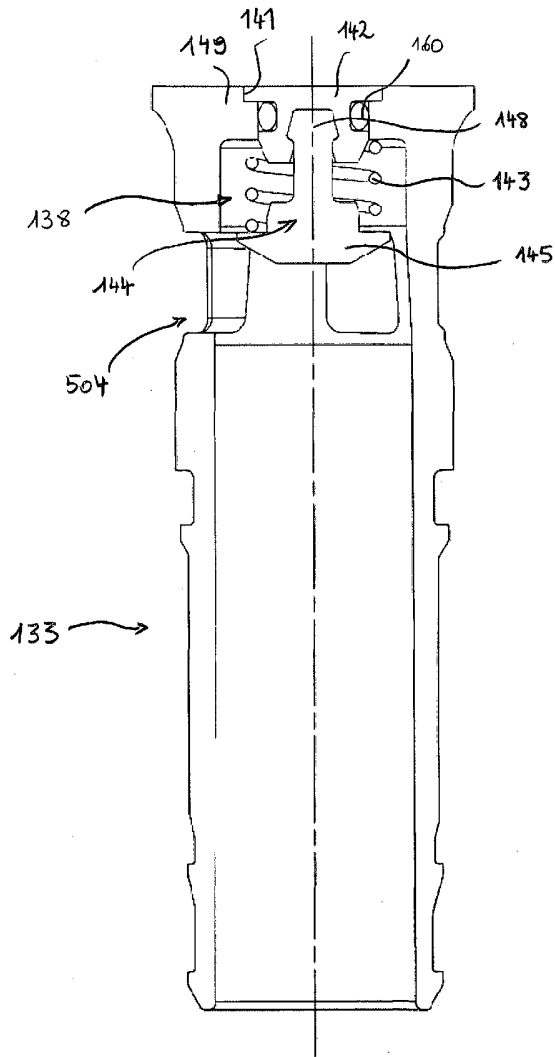

FIG. 21

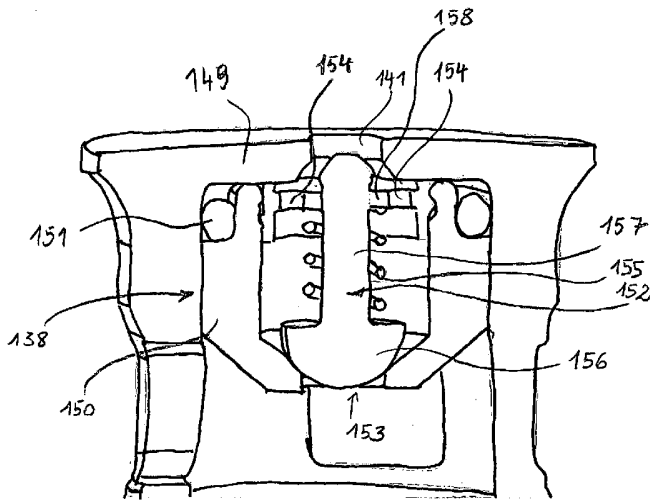

FIG. 22A

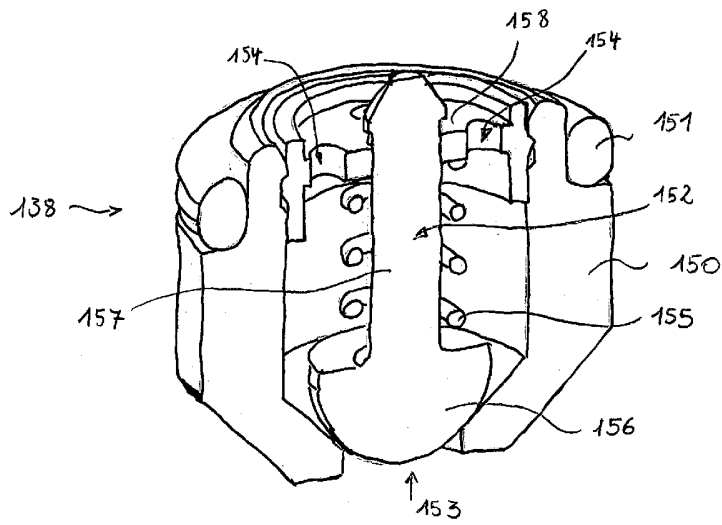

FIG. 22B