

(19) World Intellectual Property Organization
International Bureau



(43) International Publication Date
11 September 2009 (11.09.2009)

PCT

(10) International Publication Number
WO 2009/111332 A2

- (51) **International Patent Classification:**
C10J 3/00 (2006.01) C10L 3/08 (2006.01)
- (21) **International Application Number:**
PCT/US2009/035550
- (22) **International Filing Date:**
27 February 2009 (27.02.2009)
- (25) **Filing Language:** English
- (26) **Publication Language:** English
- (30) **Priority Data:**
61/032,736 29 February 2008 (29.02.2008) US
- (71) **Applicant (for all designated States except US):**
GREATPOINT ENERGY, INC. [US/US]; 222 S. Riverside Plaza, Suite 2750, Chicago, IL 60606 (US).
- (72) **Inventors; and**
- (75) **Inventors/Applicants (for US only):** **RAMAN, Patabhi, K.** [US/US]; 4420 Stonehaven Drive, Long Grove, IL 60047 (US). **LAU, Francis, S.** [US/US]; 1821 Kelly Court, Darien, IL 60561 (US). **ROBINSON, Earl, T.** [US/US]; 2135 Cypress Cross Drive, Lakeland, FL 33810 (US). **ANTHONY, Donald** [US/US]; 122 Portofino Drive, North Venice, FL 34275 (US).
- (74) **Agent:** **MIAO, Emily;** McDonnell Boehnen Hulbert & Berghoff LLP, 300 S. Wacker, Suite 3100, Chicago, IL 60606 (US).
- (81) **Designated States (unless otherwise indicated, for every kind of national protection available):** AE, AG, AL, AM, AO, AT, AU, AZ, BA, BB, BG, BH, BR, BW, BY, BZ, CA, CH, CN, CO, CR, CU, CZ, DE, DK, DM, DO, DZ, EC, EE, EG, ES, FI, GB, GD, GE, GH, GM, GT, HN, HR, HU, ID, IL, IN, IS, JP, KE, KG, KM, KN, KP, KR, KZ, LA, LC, LK, LR, LS, LT, LU, LY, MA, MD, ME, MG, MK, MN, MW, MX, MY, MZ, NA, NG, NI, NO, NZ, OM, PG, PH, PL, PT, RO, RS, RU, SC, SD, SE, SG, SK, SL, SM, ST, SV, SY, TJ, TM, TN, TR, TT, TZ, UA, UG, US, UZ, VC, VN, ZA, ZM, ZW.
- (84) **Designated States (unless otherwise indicated, for every kind of regional protection available):** ARIPO (BW, GH, GM, KE, LS, MW, MZ, NA, SD, SL, SZ, TZ, UG, ZM, ZW), Eurasian (AM, AZ, BY, KG, KZ, MD, RU, TJ, TM), European (AT, BE, BG, CH, CY, CZ, DE, DK, EE, ES, FI, FR, GB, GR, HR, HU, IE, IS, IT, LT, LU, LV, MC, MK, MT, NL, NO, PL, PT, RO, SE, SI, SK, TR), OAPI (BF, BJ, CF, CG, CI, CM, GA, GN, GQ, GW, ML, MR, NE, SN, TD, TG).
- Published:**
— without international search report and to be republished upon receipt of that report (Rule 48.2(g))



WO 2009/111332 A2

(54) **Title:** REDUCED CARBON FOOTPRINT STEAM GENERATION PROCESSES

(57) **Abstract:** Processes for the generation of steam are provided for use in an integrated catalytic gasification process for converting carbonaceous materials to combustible gases, such as methane. Generally, the exhaust gas from a steam generating reactor is provided along with steam, a carbonaceous feedstock, and a gasification catalyst, to a catalytic gasifier, wherein under appropriate temperature and pressure conditions, the carbonaceous feedstock is converted into a plurality of product gases, including, but not limited to, methane, carbon monoxide, hydrogen, and carbon dioxide. As substantially all the carbon dioxide produced from the steam generation process and the gasification process are subsequently directed through gas purification and separation processes, substantially all the carbon dioxide may be recovered, yielding a process having a near zero carbon footprint.

REDUCED CARBON FOOTPRINT STEAM GENERATION PROCESSES**Field of the Invention**

[0001] The present invention relates to methods for the production of steam for a catalytic gasification reactor which have a reduced carbon footprint.

Background of the Invention

[0002] In view of numerous factors such as higher energy prices and environmental concerns, the production of value-added gaseous products from lower-fuel-value carbonaceous feedstocks, such as biomass, coal and petroleum coke, is receiving renewed attention. The catalytic gasification of such materials to produce methane and other value-added gases is disclosed, for example, in US3828474, US3998607, US4057512, US4092125, US4094650, US4204843, US4468231, US4500323, US4541841, US4551155, US4558027, US4606105, US4617027, US4609456, US5017282, US5055181, US6187465, US6790430, US6894183, US6955695, US2003/0167961A1, US2006/0265953A1, US2007/000177A1, US2007/083072A1, US2007/0277437A1 and GB1599932.

[0003] The process for the catalytic gasification of a carbonaceous material to synthetic natural gas requires the presence of steam to react with carbon to generate methane and carbon dioxide. It has generally been contemplated to utilize coal-fired boilers to generate the required steam. Such methods have the disadvantages of requiring an additional fuel source for the boiler, while producing an exhaust comprising carbon dioxide, which is either exhausted to the atmosphere or otherwise sequestered. As such, there exists a need in the art to develop processes for the catalytic gasification of carbonaceous materials to synthetic natural gas which more efficiently utilize fuels sources, including those utilized for generating steam, while decreasing the carbon footprint of the overall process.

Summary of the Invention

[0004] In a first aspect, the present invention provides a process for generating steam and a plurality of gaseous products from a carbonaceous feedstock and recovering carbon dioxide, the process comprising the steps of: (a) supplying a first carbonaceous feedstock to a reactor, the reactor in communication with a gasifier; (b) at least partially combusting the first carbonaceous feedstock in the reactor to generate (i) heat energy and (ii) a first gas stream

comprising carbon dioxide; (c) utilizing the heat energy to generate steam; (d) introducing at least a portion of the steam, the first gas stream, a second carbonaceous feedstock, and an alkali metal gasification catalyst to the gasifier; (e) reacting the second carbonaceous feedstock in the gasifier in the presence of the steam and the alkali metal gasification catalyst and under suitable temperature and pressure to form a second gas stream comprising a plurality of gaseous products comprising methane, carbon dioxide and at least one or more of hydrogen, carbon monoxide, hydrogen sulfide, ammonia and other higher hydrocarbons; (f) at least partially separating the plurality of gaseous products to produce (i) a third gas stream comprising carbon dioxide and (ii) a fourth gas stream comprising a predominant amount of one of the gaseous products other than carbon dioxide; (g) recovering the third gas stream; and (h) recovering the fourth gas stream, wherein the third gas stream includes carbon dioxide formed in steps (b) and (e).

[0005] In a second aspect, the present invention provides a process for generating steam, electricity and a plurality of gaseous products from a carbonaceous feedstock, and recovering carbon dioxide, the process comprising the steps of: (a) supplying a first carbonaceous feedstock to a reactor, the reactor in communication with a gasifier; (b) at least partially combusting the first carbonaceous feedstock in the reactor to generate (i) heat energy and (ii) a first gas stream comprising carbon dioxide; (c) contacting water with the heat energy to generate steam; (d) dividing the steam into a first steam stream and a second steam stream; (e) introducing the first steam stream, the first gas stream, a second carbonaceous feedstock, and an alkali metal gasification catalyst to the gasifier; (f) introducing the second steam stream to a steam turbine to generate electricity; (g) reacting the second carbonaceous feedstock in the gasifier in the presence of the steam and the alkali metal gasification catalyst and under suitable temperature and pressure to form a second gas stream comprising a plurality of gaseous products comprising methane, carbon dioxide and at least one or more of hydrogen, carbon monoxide, hydrogen sulfide, ammonia and other higher hydrocarbons; (h) at least partially separating the plurality of gaseous products to produce (i) a third gas stream comprising carbon dioxide and (ii) a fourth gas stream comprising a predominant amount of one of the gaseous products other than carbon dioxide; (i) recovering the third gas stream; and (j) recovering the fourth gas stream, wherein the third gas stream includes carbon dioxide formed in steps (b) and (g).

Brief Description of the Drawings

[0006] **Figure 1** is a flow chart illustrating a method for generating gases from a carbonaceous feedstock according to the present invention.

Detailed Description

[0007] The present invention relates to methods for generating high-pressure and high-temperature steam for providing to a catalytic gasification reactor, which methods result in reduced to near zero carbon footprints due to the capture of the carbon dioxide (and substantially all of the carbon dioxide) produced in the process. Such methods can be integrated into processes for the catalytic gasification of carbonaceous feedstock and/or for generating electricity.

[0008] The present invention can be practiced, for example, using any of the developments to catalytic gasification technology disclosed in commonly owned US2007/0000177A1, US2007/0083072A1 and US2007/0277437A1; and U.S. Patent Application Serial Nos. 12/178,380 (filed 23 July 2008), 12/234,012 (filed 19 September 2008) and 12/234,018 (filed 19 September 2008). All of the above are incorporated by reference herein for all purposes as if fully set forth.

[0009] Moreover, the present invention can be practiced in conjunction with the subject matter of the following U.S. Patent Applications, each of which was filed on December 28, 2008: Serial No. 12/342,554, entitled "CATALYTIC GASIFICATION PROCESS WITH RECOVERY OF ALKALI METAL FROM CHAR"; Serial No. 12/342,565, entitled "PETROLEUM COKE COMPOSITIONS FOR CATALYTIC GASIFICATION"; Serial No. 12/342,578, entitled "COAL COMPOSITIONS FOR CATALYTIC GASIFICATION"; Serial No. 12/342,596, entitled "PROCESSES FOR MAKING SYNTHESIS GAS AND SYNGAS-DERIVED PRODUCTS"; Serial No. 12/342,608, entitled "PETROLEUM COKE COMPOSITIONS FOR CATALYTIC GASIFICATION"; Serial No. 12/342,628, entitled "PROCESSES FOR MAKING SYNGAS-DERIVED PRODUCTS"; Serial No. 12/342,663, entitled "CARBONACEOUS FUELS AND PROCESSES FOR MAKING AND USING THEM"; Serial No. 12/342,715, entitled "CATALYTIC GASIFICATION PROCESS WITH RECOVERY OF ALKALI METAL FROM CHAR"; Serial No. 12/342,736, entitled "CATALYTIC GASIFICATION PROCESS WITH RECOVERY OF ALKALI METAL FROM CHAR"; Serial No. 12/343,143, entitled "CATALYTIC GASIFICATION PROCESS WITH RECOVERY OF ALKALI METAL FROM CHAR"; Serial No. 12/343,149, entitled

“STEAM GENERATING SLURRY GASIFIER FOR THE CATALYTIC GASIFICATION OF A CARBONACEOUS FEEDSTOCK”; and Serial No. 12/343,159, entitled “CONTINUOUS PROCESSES FOR CONVERTING CARBONACEOUS FEEDSTOCK INTO GASEOUS PRODUCTS”. All of the above are incorporated by reference herein for all purposes as if fully set forth.

[0010] Further, the present invention can be practiced in conjunction with the subject matter of the following U.S. Patent Applications, each of which was filed concurrently herewith: Serial No. _____, entitled “PROCESSES FOR MAKING ABSORBENTS AND PROCESSES FOR REMOVING CONTAMINANTS FROM FLUIDS USING THEM” (attorney docket no. FN-0019 US NP1); Serial No. _____, entitled “STEAM GENERATION PROCESSES UTILIZING BIOMASS FEEDSTOCKS” (attorney docket no. FN-0020 US NP1); Serial No. _____, entitled “PROCESS AND APPARATUS FOR THE SEPARATION OF METHANE FROM A GAS STREAM” (attorney docket no. FN-0022 US NP1); Serial No. _____, entitled “SELECTIVE REMOVAL AND RECOVERY OF ACID GASES FROM GASIFICATION PRODUCTS” (attorney docket no. FN-0023 US NP1); Serial No. _____, entitled “COAL COMPOSITIONS FOR CATALYTIC GASIFICATION” (attorney docket no. FN-0024 US NP1); Serial No. _____, entitled “COAL COMPOSITIONS FOR CATALYTIC GASIFICATION” (attorney docket no. FN-0025 US NP1); Serial No. _____, entitled “CO-FEED OF BIOMASS AS SOURCE OF MAKEUP CATALYSTS FOR CATALYTIC COAL GASIFICATION” (attorney docket no. FN-0026 US NP1); Serial No. _____, entitled “COMPACTOR-FEEDER” (attorney docket no. FN-0027 US NP1); Serial No. _____, entitled “CARBONACEOUS FINES RECYCLE” (attorney docket no. FN-0028 US NP1); Serial No. _____, entitled “BIOMASS CHAR COMPOSITIONS FOR CATALYTIC GASIFICATION” (attorney docket no. FN-0029 US NP1); Serial No. _____, entitled “CATALYTIC GASIFICATION PARTICULATE COMPOSITIONS” (attorney docket no. FN-0030 US NP1); and Serial no. _____, entitled “BIOMASS COMPOSITIONS FOR CATALYTIC GASIFICATION” (attorney docket no. FN-0031 US NP1). All of the above are incorporated herein by reference for all purposes as if fully set forth.

[0011] All publications, patent applications, patents and other references mentioned herein, if not otherwise indicated, are explicitly incorporated by reference herein in their entirety for all purposes as if fully set forth.

[0012] Unless otherwise defined, all technical and scientific terms used herein have the same meaning as commonly understood by one of ordinary skill in the art to which this invention belongs. In case of conflict, the present specification, including definitions, will control.

[0013] Except where expressly noted, trademarks are shown in upper case.

[0014] Although methods and materials similar or equivalent to those described herein can be used in the practice or testing of the present invention, suitable methods and materials are described herein.

[0015] Unless stated otherwise, all percentages, parts, ratios, *etc.*, are by weight.

[0016] When an amount, concentration, or other value or parameter is given as a range, or a list of upper and lower values, this is to be understood as specifically disclosing all ranges formed from any pair of any upper and lower range limits, regardless of whether ranges are separately disclosed. Where a range of numerical values is recited herein, unless otherwise stated, the range is intended to include the endpoints thereof, and all integers and fractions within the range. It is not intended that the scope of the present invention be limited to the specific values recited when defining a range.

[0017] When the term "about" is used in describing a value or an end-point of a range, the invention should be understood to include the specific value or end-point referred to.

[0018] As used herein, the terms "comprises," "comprising," "includes," "including," "has," "having" or any other variation thereof, are intended to cover a non-exclusive inclusion. For example, a process, method, article, or apparatus that comprises a list of elements is not necessarily limited to only those elements but can include other elements not expressly listed or inherent to such process, method, article, or apparatus. Further, unless expressly stated to the contrary, "or" refers to an inclusive or and not to an exclusive or. For example, a condition A or B is satisfied by any one of the following: A is true (or present) and B is false (or not present), A is false (or not present) and B is true (or present), and both A and B are true (or present).

[0019] The use of "a" or "an" to describe the various elements and components herein is merely for convenience and to give a general sense of the invention. This description should be read to include one or at least one and the singular also includes the plural unless it is obvious that it is meant otherwise.

[0020] The materials, methods, and examples herein are illustrative only and, except as specifically stated, are not intended to be limiting.

Steam Generation Methods

[0021] The steam generating processes of the present invention are particularly useful in an integrated catalytic gasification process for converting carbonaceous materials to combustible gases, such as methane, while achieving a low or near zero carbon footprint, due the capture of carbon dioxide produced in the process (*e.g.*, in steps (b) and (e) of the first aspect, and steps (b) and (g) of the second aspect). Typically, as much of this carbon dioxide should be captured, and substantially all should be captured, where possible.

[0022] A typical flow chart for integration into a process for generating a combustible gas from a carbonaceous feedstock is illustrated in Figure 1, and referenced herein. Generally, steam and a carbonaceous feedstock are provided to a gasifier (200), wherein under appropriate temperature and pressure conditions, and in the presence of one or more gasification catalysts, the carbonaceous feedstock is converted into a plurality of product gases, including, but not limited to, methane, carbon monoxide, hydrogen, and carbon dioxide.

[0023] The steam is generated from action of reactor (100) and is conveyed via a heated gas conduit (110) from the reactor to the catalytic gasifier (200). Reactor (100) includes, but is not limited to, commercial gasification reactors, oxy-fuel combustors, and boilers.

[0024] Reactor (100) is fed with a first carbonaceous feedstock (404), from a feedstock preparation operation (402), and generally may comprise one or a mixture of any carbonaceous material. For example, the first carbonaceous feedstock may comprise one or more biomasses; or one or more non-biomasses, such as coal and/or petroleum coke; or a mixture of biomasses and non-biomasses. In one example, fines (403, *e.g.*, coal fines) generated in the crushing of carbonaceous materials for the preparation of a second carbonaceous feedstock (401) for the gasifier (200) can be used in preparing feedstock (404). Notably, a second source for fines can be from waste fines from bituminous coal cleaning and existing waste coal impoundments or ponds, thereby aiding in improving and preventing environmental pollution as a result of mining and processing operations. Alternatively, the first carbonaceous feedstock (404) may comprise any combustible gas, such as methane, carbon monoxide, hydrogen, natural gas, butane, and mixtures thereof.

[0025] The at least partial gasification or at least partial combustion of the first carbonaceous feedstock in reactor (100) generates large amounts of heat energy and an exhaust gas comprising at least carbon dioxide.

[0026] Advantageously, this heat energy can be used to contact any type of heat exchanger, in contact with a water source, to generate steam. For example, any of the boilers known to those skilled in the art can supply steam to gasifier (200). While any water source can be used

to generate steam, the water commonly used in known boiler systems is purified and deionized (about 0.3-1.0 $\mu\text{S}/\text{cm}$) so that corrosive processes are slowed. Such boilers can be powered, for example, through the oxygen-blown combustion of any carbonaceous material, including pulverized/powdered coal, biomass, and rejected carbonaceous materials from the feedstock preparation operation (*e.g.*, fines, *supra*). Ultimately, the thermal energy from the gasification or combustion of the first carbonaceous feedstock may heat the water in reactor (100), which eventually converts into steam (typically at about 1300°F and 500 psi).

[0027] The steam produced by action of the reactor (100) can be generally variable based on the type of reactor and feedstock being utilized. Preferably, the steam can be provided to the catalytic gasifier in the range of about 550 psia to about 600 psia and about 1300°F to about 1400°F (about 700°C to about 760°C). More preferably, reactor (100) produces steam at a pressure essentially the same as the conditions being utilized in the catalytic gasifier (200), as any excess heat can be more efficiently captured for use in other operations (*e.g.*, feedstock drying).

[0028] In another example, the contacting of water with the heat energy to produce steam may be occur within reactor (100) either by the addition of water to the reactor via a separate feed line (103), or by supplying a first carbonaceous feedstock (404), for example, as an aqueous slurry of the carbonaceous material, such as described in previously incorporated US Patent Application Serial No. 12/343,149. In this embodiment, the water (for preparing the aqueous slurry and/or fed into the reactor) can either be produced from a clean water feed (*e.g.*, a municipal water supply) and/or recycle processes. For example, reclaimed water from sour water stripping operation and/or catalytic feedstock drying operations can be used. In one embodiment, the water is not clean but instead contains organic matter, such as untreated wastewater from farming, coal mining, and municipal waste treatment facilities or like sources. The organic matter in the wastewater becomes part of the carbonaceous feedstock.

[0029] Further, the exhaust gas generated from either gasification or combustion of the first carbonaceous feedstock in reactor (100) is supplied either (i) combined with the generated steam via heated conduit (110) or via a second heated conduit (120) to catalytic gasifier (200). In the cases where reactor (100) is an oxy-combustion reactor or a fired boiler, the exhaust gas generated may comprise carbon dioxide, and optionally steam. In the cases where reactor (100) is a second gasification reactor, then the exhaust gas may comprise carbon monoxide, hydrogen, and optionally, steam, carbon dioxide, and/or methane. For example, steam can be generated within a slurry gasifier which produces steam and synthesis gas from an aqueous carbonaceous feed slurry, such as described in in previously

incorporated US Patent Application Serial No. 12/343,149. By directing the exhaust gas from reactor (100), produced by the generation of steam, through the catalytic gasifier (200) and the associated gas purification and separation unit operations (*supra*), essentially all the carbon dioxide produced from the steam generation process as well as from the gasification of a second carbonaceous material may be recovered, yielding an overall catalytic gasification process having a reduced or near zero, or possibly negative, carbon footprint.

[0030] By “carbon footprint”, reference is made to the carbon dioxide released into the environment from non-biomass sources, for example, from the combustion of fossil fuels and release of the resulting carbon dioxide into the atmosphere. Capture and sequestration of all carbon dioxide generated from non-biomass sources would be considered to have a neutral carbon footprint, as no carbon dioxide would have been released into the atmosphere.

[0031] By contrast, the release of carbon dioxide into the atmosphere from biomass sources is considered carbon footprint neutral, since biomass is created (for example, directly as a plant, or indirectly as part of the food chain) by the capture and conversion of carbon dioxide from the atmosphere. As such, the capture and sequestration of carbon dioxide generated from biomass sources can actually result in a negative (reduced) carbon footprint.

[0032] Steam can also be supplied from a second gasification reactor (100) coupled with a combustion turbine, the exhaust of which contacts a heat exchanger in contact with a water source (*e.g.*, a boiler system), to produce steam. The steam and exhaust gas (from the combustion turbine) so produced may be provided to the gasifier, as discussed previously.

[0033] The steam generated by reactor (100) may be routed, in whole or in part, into one or more heated conduits (105), which may be located at or near an exit conduit carrying the combustion gases. For example, the steam may be divided into a plurality of steam streams (*e.g.*, into a first and second steam stream), each comprising a portion of the steam. Each steam stream can be routed in a variety of directions; for example, one or more steam streams may be provided to the gasification reactor via a heated conduit (110); or one or more steam streams can be used to dry a carbonaceous feedstock (*e.g.*, via heated conduit 130); or one or more steam streams can be routed to a steam turbine (2000, via heated conduit 140) for generation of electricity (2001). In order to avoid excessive cooling of the steam during transport, the heated conduits may be superheated according to methods known to those skilled in the art (*e.g.*, via contact with a heat exchanger) prior to delivery of the steam to any endpoint. In one particular example, all the steam generated from reactor (100) is provided to gasifier (200).

[0034] Recycled steam from other process operations can also be used for supplementing steam to the catalytic gasifier. For example in the preparation of the second carbonaceous feedstock, when slurried particulate composition may be dried with a fluid bed slurry drier, as discussed below, then the steam generated can be fed to the catalytic gasification reactor (200).

[0035] The small amount of required heat input for the catalytic gasifier can be provided by, for example, superheating the steam provided to the gasifier; or superheating a mixture of the steam and any second gas source feeding the gasification reactor by any method known to one skilled in the art. In one method, compressed recycle gas of CO and H₂ (902, *supra*) can be mixed with the steam and the resulting steam/recycle gas mixture can be further superheated by heat exchange with the catalytic gasifier effluent followed by superheating in a recycle gas furnace.

Catalytic Gasification Methods

[0036] The gas utilized in the catalytic gasifier (200) for pressurization and reactions of the second carbonaceous feedstock comprises steam, and optionally, other gases such as oxygen or air, carbon monoxide and hydrogen.

[0037] The catalytic gasification reactor (catalytic gasifier; 200) is typically operated at moderately high pressures and temperature, requiring introduction of a second carbonaceous feedstock (405) and a gasification catalyst (*e.g.*, an alkali metal gasification catalyst) to a reaction zone of the catalytic gasifier while maintaining the required temperature, pressure, and flow rate of the feedstock. Those skilled in the art are familiar with feed systems for providing feedstocks to high pressure and/or temperature environments, including, star feeders, screw feeders, rotary pistons, and lock-hoppers. It should be understood that the feed system can include two or more pressure-balanced elements, such as lock hoppers, which would be used alternately.

[0038] The second carbonaceous feedstock and gasification catalyst may be introduced separately or combined as a single catalyzed feedstock (*supra*) and is generally provided to the catalytic gasifier (200) from a feedstock preparation operation (400). In some instances, the second carbonaceous feedstock (405) can be prepared at pressures conditions above the operating pressure of catalytic gasifier. Hence, the second carbonaceous feedstock (405) may be directly passed into the catalytic gasifier without further pressurization.

[0039] Any of several catalytic gasifiers (200) can be utilized in the process of the described herein. Suitable gasifiers include counter-current fixed bed, co-current fixed bed, fluidized bed, entrained flow, and moving bed reactors. A catalytic gasifier for gasifying liquid feeds, such as liquid petroleum residues, is disclosed in previously incorporated US6955695.

[0040] The pressure in the catalytic gasifier (200) typically can be from about 10 to about 100 atm (from about 150 to about 1500 psig). The gasification reactor temperature can be maintained around at least about 450°C, or at least about 600°C, or at least about 900°C, or at least about 750°C, or about 600°C to about 700°C; and at pressures of at least about 50 psig, or at least about 200 psig, or at least about 400 psig, to about 1000 psig, or to about 700 psig, or to about 600 psig.

[0041] In one embodiment, a methane reformer (1000) can be optionally included in the process. For example, when reactor (100) is a gasification reactor, a methane reformer (1000) may be included in the process to supplement the recycle CO and H₂ stream and the exhaust gas (120, as shown in Figure 1) and/or steam stream (110) from the reactor to ensure that enough recycle gas is supplied to the reactor so that the net heat of reaction is as close to neutral as possible (only slightly exothermic or endothermic), in other words, that the catalytic gasifier is run under substantially thermally neutral conditions. In such instances, methane (901a) can be supplied for the reformer from the methane product (901), as described below.

[0042] Reaction of the second carbonaceous feedstock (405) in the catalytic gasifier (200), in the presence of one or more gasification catalysts, and the first carbonaceous feedstock (404) in reactor (100), under the described conditions, provides a crude product gas. Since the exhaust gas (120) from reactor (100) is provided in whole to the gasifier (200), the crude product gas comprises essentially all the carbon dioxide produced from reactor (100) and gasifier (200). Additionally, both reactor (100) and gasifier (200) produce a char (102 and 202, respectively).

[0043] The char produced in the catalytic gasifier (202) processes is typically removed from the catalytic gasifier for sampling, purging, and/or catalyst recovery in a continuous or batch-wise manner. Methods for removing char are well known to those skilled in the art. One such method taught by EP-A-0102828, for example, can be employed. The char can be periodically withdrawn from the catalytic gasification reactor through a lock hopper system, although other methods are known to those skilled in the art.

[0044] Often, the char (202) from the catalytic gasifier is directed to a catalyst recovery and recycle process (300). Processes have been developed to recover alkali metal from the solid

purge in order to reduce raw material costs and to minimize environmental impact of a catalytic gasification process. For example, the char (202) can be quenched with recycle gas and water and directed to a catalyst recycling operation for extraction and reuse of the alkali metal catalyst. Particularly useful recovery and recycling processes are described in US4459138, as well as previously incorporated US4057512 and US2007/0277437A1, and previously incorporated U.S. Patent Application Serial Nos. 12/342,554, 12/342,715, 12/342,736 and 12/343,143. Reference can be had to those documents for further process details.

[0045] Upon completion of catalyst recovery, both the char, substantially free of the gasification catalysts (302) as described herein, and the recovered catalyst (301) (as a solution or solid) can be directed to the feedstock preparation operation (400) comprising a second carbonaceous feedstock preparation process (401) and a steam feedstock preparation process (402), as described herein. The char (202) can, for example, be utilized as the first carbonaceous feedstock.

[0046] The char (102) produced in reactor (100) is typically removed via similar methods to those described for the catalytic gasification reactor. However, the char from reactor (100) is not normally processed through catalyst recovery, but rather, can be processed for disposal. Certain biomasses, however, contain alkali metal content, thus the char from such biomass may be recovered and extracted to provide a leachate for preparing the second carbonaceous feedstock (405), as described in previously incorporated US Patent Application Serial No. _____, , entitled "CATALYTIC GASIFICATION PARTICULATE COMPOSITIONS" (attorney docket no. FN-0030 US NP1); or may be recovered and utilized, itself, as part of the second carbonaceous feedstock (405), as described in previously incorporated US Patent Application Serial No. _____, entitled "BIOMASS CHAR COMPOSITIONS FOR CATALYTIC GASIFICATION" (attorney docket no. FN-0029 US NP1).

[0047] Crude product gas effluent leaving the catalytic gasifier (200) can pass through a portion of the reactor which serves as a disengagement zone where particles too heavy to be entrained by the gas leaving the reactor (*i.e.*, fines) are returned to the fluidized bed. The disengagement zone can include one or more internal cyclone separators or similar devices for removing fines and particulates from the gas. The gas effluent (201) passing through the disengagement zone and leaving the catalytic gasifier generally contains CH₄, CO₂, H₂ and CO, H₂S, NH₃, other higher hydrocarbons, unreacted steam, entrained fines, and other contaminants such as COS.

[0048] The gas stream from which the fines have been removed (201) can then be passed through a heat exchanger (500) to cool the gas and the recovered heat can be used to preheat recycle gas and generate high pressure steam (501). Residual entrained fines can also be removed by any suitable means such as external cyclone separators, optionally followed by Venturi scrubbers. The recovered fines can be processed to recover alkali metal catalyst then passed to the slurry feedstock preparation process (402) or returned to the catalytic gasification reactor, or directly recycled back to feedstock preparation as described in previously incorporated US Patent Application Serial No. _____, entitled "CARBONACEOUS FINES RECYCLE" (attorney docket no. FN-0028 US NP1).

[0049] The gas stream (502) from which the fines have been removed can be fed to a gas purification operation (600) comprising COS hydrolysis reactors (601) for COS removal (sour process) and further cooled in a heat exchanger to recover residual heat prior to entering water scrubbers (602) for ammonia recovery, yielding a scrubbed gas comprising at least H₂S, CO₂, CO, H₂, and CH₄. Methods for COS hydrolysis are known to those skilled in the art, for example, see US4100256. The residual heat from the scrubbed gas can be used to generate low pressure steam.

[0050] Scrubber water (605) and sour process condensate (604) can be processed to strip and recover H₂S, CO₂ and NH₃; such processes are well known to those skilled in the art. NH₃ can typically be recovered as an aqueous solution (*e.g.*, 20 wt%). Alternatively, scrubber water (605) and sour process condensate (604) can be returned to the slurry gasifier, thereby reducing overall process water usage and eliminating separate cleanup of these process streams.

[0051] A subsequent acid gas removal process (603) can be used to remove H₂S and CO₂ from the scrubbed gas stream by a physical absorption method involving solvent treatment of the gas to give a cleaned gas stream. Such processes involve contacting the scrubbed gas with a solvent such as monoethanolamine, diethanolamine, methyldiethanolamine, diisopropylamine, diglycolamine, a solution of sodium salts of amino acids, methanol, hot potassium carbonate or the like. One method can involve the use of Selexol[®] (UOP LLC, Des Plaines, IL USA) or Rectisol[®] (Lurgi AG, Frankfurt am Main, Germany) solvent having two trains; each train consisting of an H₂S absorber and a CO₂ absorber. The spent solvent (607) containing H₂S, CO₂ and other contaminants can be regenerated by any method known to those skilled in the art, including contacting the spent solvent with steam or other stripping gas to remove the contaminants or by passing the spent solvent through stripper columns. Recovered acid gases can be sent for sulfur recovery processing; for example, any recovered

H₂S from the acid gas removal and sour water stripping can be converted to elemental sulfur by any method known to those skilled in the art, including the Claus process. Sulfur can be recovered as a molten liquid. Stripped water can be directed for recycled use in preparation of the first and/or second carbonaceous feedstock. One method for removing acid gases from the scrubbed gas stream is described in previously incorporated US Patent Application Serial No. __/_____, entitled "SELECTIVE REMOVAL AND RECOVERY OF ACID GASES FROM GASIFICATION PRODUCTS" (attorney docket no. FN-0023 US NP1).

[0052] Advantageously, CO₂ generated in the process, whether in the steam generation or catalytic gasification or both, can be recovered for subsequent use or sequestration, enabling a greatly decreased carbon footprint (as compared to direct combustion of the feedstock) as a result. For example, steam may be generated with reduced carbon footprint as described in previously incorporated US Patent Application Serial No. __/_____, entitled "STEAM GENERATION PROCESSES UTILIZING BIOMASS FEEDSTOCKS" (attorney docket no. FN-0020 US NP1).

[0053] The resulting cleaned gas stream (606) exiting the gas purification operation (600) contains mostly CH₄, H₂, and CO and, typically, small amounts of CO₂ and H₂O. The cleaned gas stream (606) can be further processed to separate and recover CH₄ by any suitable gas separation method (900) known to those skilled in the art including, but not limited to, cryogenic distillation and the use of molecular sieves or ceramic membranes, or via the generation of methane hydrate as disclosed in previously incorporated US Patent Application Serial No. __/_____, entitled "PROCESS AND APPARATUS FOR THE SEPARATION OF METHANE FROM A GAS STREAM" (attorney docket no. FN-0022 US NP1).

[0054] Typically, two gas streams can be produced by the gas separation process (900), a methane product stream (901) and a syngas stream (902, H₂ and CO). The syngas stream (902) can be compressed and recycled. One option can be to recycle the syngas steam directly to the catalytic gasifier (200). In one case, the recycled syngas is combined with the exhaust gas (101) from the slurry gasifier, and the mixture introduced into the catalytic gasification reactor. In another case, as exemplified in Figure 2, the recycled syngas (902) can be directed into the slurry gasifier (100). When a fluid bed reactor is utilized for the slurry gasifier (100), the syngas may provide fluidization or aid in fluidization of the reaction bed.

[0055] If necessary, a portion of the methane product (901a) can be directed to a reformer, as discussed previously. The need to direct a portion of the methane product can be controlled,

for example, by the ratio of CO to H₂ in the exhaust gas from the slurry gasifier (100). Particularly, methane can be directed to a reformer to supplement (1001) the exhaust gas (101) supplied to the catalytic gasification reactor and, in some instance, provide a ratio of about 3:1 of H₂ to CO in the feed to the catalytic gasification reactor. A portion of the methane product can also be used as plant fuel for a gas turbine.

Carbonaceous Feedstocks

[0056] The carbonaceous feedstocks supplied to the catalytic gasifier (200) and the steam generating reactor (100) may comprise any one or combination of carbonaceous materials. Such feedstocks supplied to the catalytic gasifier and steam generating reactor may be same or different. In one embodiment, the first, second or both carbonaceous feedstocks comprise biomass. In another embodiment, the first, second, or both carbonaceous feedstocks comprise non-biomass carbonaceous material. In yet another embodiment, the first, second, or both carbonaceous feedstocks comprise biomass and non-biomass carbonaceous material.

[0057] The second carbonaceous feedstock (405) for the catalytic gasifier typically comprises at least one carbonaceous material, as discussed previously, and a gasification catalyst.

[0058] The first and/or second carbonaceous feedstock may be supplied as a particulate. Generally, the particulates independently have an average particle size of from about 25 microns, or from about 45 microns, up to about 500, or up to about 2500 microns. One skilled in the art can readily determine the appropriate particle size for the individual particulates and the first and second carbonaceous feedstocks. For example, when a fluid bed gasification reactor is used as reactor (100) and/or gasifier (200), the first and/or second carbonaceous feedstock can have an average particle size which enables incipient fluidization of the carbonaceous feedstock at the gas velocity used in the fluid bed gasification reactor.

[0059] The term "carbonaceous material" as used herein refers to any carbonaceous material including, but not limited to coal, petroleum coke, asphaltenes, liquid petroleum residues, used motor oil and other waste processed petroleum sources, untreated or treated sewage waste, garbage, plastics, wood and other biomass, or mixtures thereof. The carbonaceous materials for the feedstock can comprise carbon sources containing at least about 20%, or at least about 30%, or at least about 40%, or at least about 50%, or at least about 60%, or at least about 70%, or at least about 80% carbon by dry weight.

[0060] The term "biomass", as used herein refers to carbonaceous materials derived from recently (for example, within the past 100 years) living organisms, including plant-based

biomass and animal-based biomass. For clarification, biomass does not include fossil-based carbonaceous materials, such as coal.

[0061] The term “plant-based biomass” as used herein means materials derived from green plants, crops, algae, and trees, such as, but not limited to, sweet sorghum, bagasse, sugarcane, bamboo, hybrid poplar, hybrid willow, albizia trees, eucalyptus, alfalfa, clover, oil palm, switchgrass, sudangrass, millet, jatropha, and miscanthus (*e.g.*, *Miscanthus x giganteus*). Biomass further include wastes from agricultural cultivation, processing, and/or degradation such as corn cobs and husks, corn stover, straw, nut shells, vegetable oils, canola oil, rapeseed oil, biodiesels, tree bark, wood chips, sawdust, and yard wastes.

[0062] The term “animal-based biomass” as used herein means wastes generated from animal cultivation and/or utilization. For example, biomass includes, but is not limited to, wastes from livestock cultivation and processing such as animal manure, guano, poultry litter, animal fats, and municipal solid wastes (*e.g.*, sewage).

[0063] The term “non-biomass”, as used herein, means those carbonaceous materials which are not encompassed by the term “biomass” as defined herein. For example, non-biomass include, but is not limited to, anthracite, bituminous coal, sub-bituminous coal, lignite, petroleum coke, asphaltenes, liquid petroleum residues, or mixtures thereof.

[0064] The term “petroleum coke” as used herein includes (i) the solid thermal decomposition product of high-boiling hydrocarbon fractions obtained in petroleum processing (heavy residues); and (ii) the solid thermal decomposition product of processing tar sands (bituminous sands or oil sands) Such carbonization products include, for example, green, calcined, needle and fluidized bed petroleum coke. Petroleum coke is generally prepared via delayed coking or fluid coking. The petroleum coke can be residual material remaining after retorting tar sands (*e.g.*, mined) are heated to extract any oil.

[0065] Resid petcoke can also be derived from a crude oil, for example, by coking processes used for upgrading heavy-gravity residual crude oil, which petroleum coke contains ash as a minor component, typically about 1.0 wt% or less, and more typically about 0.5 wt% of less, based on the weight of the coke. Typically, the ash in such lower-ash cokes predominantly comprises metals such as nickel and vanadium.

[0066] Tar sands petcoke can be derived from an oil sand, for example, by coking processes used for upgrading oil sand. Tar sands petcoke contains ash as a minor component, typically in the range of about 2 wt% to about 12 wt%, and more typically in the range of about 4 wt% to about 12 wt%, based on the overall weight of the tar sands petcoke. Typically, the ash in

such higher-ash cokes predominantly comprises materials such as compounds of silicon and/or aluminum.

[0067] The petroleum coke can comprise at least about 70 wt% carbon, at least about 80 wt% carbon, or at least about 90 wt% carbon, based on the total weight of the petroleum coke. Typically, the petroleum coke comprises less than about 20 wt% percent inorganic compounds, based on the weight of the petroleum coke.

[0068] The term “liquid petroleum residue” as used herein includes both (i) the liquid thermal decomposition product of high-boiling hydrocarbon fractions obtained in petroleum processing (heavy residues – “resid liquid petroleum residue”) and (ii) the liquid thermal decomposition product of processing tar sands (bituminous sands or oil sands – “tar sands liquid petroleum residue”). The liquid petroleum residue is substantially non-solid; for example, it can take the form of a thick fluid or a sludge.

[0069] Resid liquid petroleum residue can also be derived from a crude oil, for example, by processes used for upgrading heavy-gravity crude oil distillation residue. Such liquid petroleum residue contains ash as a minor component, typically about 1.0 wt% or less, and more typically about 0.5 wt% or less, based on the weight of the residue. Typically, the ash in such lower-ash residues predominantly comprises metals such as nickel and vanadium.

[0070] Tar sands liquid petroleum residue can be derived from an oil sand, for example, by processes used for upgrading oil sand. Tar sands liquid petroleum residue contains ash as a minor component, typically in the range of about 2 wt% to about 12 wt%, and more typically in the range of about 4 wt% to about 12 wt%, based on the overall weight of the residue. Typically, the ash in such higher-ash residues predominantly comprises materials such as compounds of silicon and/or aluminum.

[0071] The term “coal” as used herein means peat, lignite, sub-bituminous coal, bituminous coal, anthracite, graphite, or mixtures thereof. In certain embodiments, the coal has a carbon content of less than about 85%, or less than about 80%, or less than about 75%, or less than about 70%, or less than about 65%, or less than about 60%, or less than about 55%, or less than about 50% by weight, based on the total coal weight. In other embodiments, the coal has a carbon content ranging up to about 85%, or up to about 80%, or up to about 75% by weight, based on total coal weight. Examples of useful coals include, but are not limited to, Illinois #6, Pittsburgh #8, Beulah (ND), Utah Blind Canyon, and Powder River Basin (PRB) coals. Anthracite, bituminous coal, sub-bituminous coal, and lignite coal may contain about 10 wt%, from about 5 to about 7 wt%, from about 4 to about 8 wt %, and from about 9 to about 11 wt%, ash by total weight of the coal on a dry basis, respectively. However, the ash

content of any particular coal source will depend on the rank and source of the coal, as is familiar to those skilled in the art (see, for example, *Coal Data: A Reference*, Energy Information Administration, Office of Coal, Nuclear, Electric and Alternate Fuels, U.S. Department of Energy, DOE/EIA-0064(93), February 1995).

[0072] Asphaltenes typically comprise aromatic carbonaceous solids at room temperature, and can be derived, from example, from the processing of crude oil, oil shale, bitumen, and tar sands.

Catalyst Components

[0073] As noted above, the second carbonaceous feedstock and gasification catalyst may be introduced to gasifier (200) separately or combined as a single catalyzed feedstock. Suitable gasification catalysts include, but are not limited to, alkali metals such as lithium, sodium, potassium, rubidium, cesium, and mixtures thereof. Particularly useful are potassium sources. Suitable alkali metal compounds include alkali metal carbonates, bicarbonates, formates, oxalates, amides, hydroxides, acetates, or similar compounds. For example, the catalyst can comprise one or more of Na_2CO_3 , K_2CO_3 , Rb_2CO_3 , Li_2CO_3 , Cs_2CO_3 , NaOH , KOH , RbOH or CsOH , and particularly, potassium carbonate and/or potassium hydroxide.

[0074] The second carbonaceous feedstock, in certain embodiments, further comprises an amount of an alkali metal component, as an alkali metal and/or an alkali metal compound, as well as optional co-catalysts, as disclosed in the previous incorporated references. Typically, the quantity of the alkali metal component in the composition is sufficient to provide a ratio of alkali metal atoms to carbon atoms ranging from about 0.01, or from about 0.02, or from about 0.03, or from about 0.04, to about 0.06, or to about 0.07, or to about 0.08. Further, the alkali metal is typically loaded onto a carbon source to achieve an alkali metal content of from about 3 to about 10 times more than the combined ash content of the carbonaceous material (*e.g.*, coal and/or petroleum coke), on a mass basis.

Methods for Making a Catalyzed Feedstock

[0075] The second carbonaceous feedstock (405) may comprise a particulate composition of one or more carbonaceous materials and a gasification catalyst (*i.e.*, a catalyzed feedstock). Each carbonaceous material may require initial processing to prepare or catalytic gasification. For example, when using a second carbonaceous feedstock comprising a mixture of two or more carbonaceous materials, such as petroleum coke and coal, the petroleum coke and coal

can be separately processed to add catalyst to one or both portions, and subsequently mixed. Alternately, the carbonaceous materials can be combined immediately prior to the addition of a catalyst.

[0076] The carbonaceous materials can be crushed and/or ground according to any methods known in the art, such as impact crushing and wet or dry grinding to yield particulates of each. Depending on the method utilized for crushing and/or grinding of the carbonaceous material, the resulting particulates can be sized (*i.e.*, separated according to size) to provide an appropriate feedstock.

[0077] Any method known to those skilled in the art can be used to size the particulates. For example, sizing can be preformed by screening or passing the particulates through a screen or number of screens. Screening equipment can include grizzlies, bar screens, and wire mesh screens. Screens can be static or incorporate mechanisms to shake or vibrate the screen. Alternatively, classification can be used to separate the petroleum coke and coal particulates. Classification equipment can include ore sorters, gas cyclones, hydrocyclones, rake classifiers, rotating trommels, or fluidized classifiers. The carbonaceous material can be also sized or classified prior to grinding and/or crushing. Any fines (**403**) separated from the preparation process can be directed to preparation (**402**) of the feedstock for the reactor (**100**).

[0078] Additional feedstock processing steps may be necessary depending on the qualities of carbonaceous materials. For example, carbonaceous materials containing high moisture levels, such as raw and/or treated sewage and high-moisture coals, can require drying prior to crushing. Some caking coals can require partial oxidation to simplify gasification reactor operation. Various coals deficient in ion-exchange sites can be pre-treated to create additional ion-exchange sites to facilitate catalysts loading and/or association. Such pre-treatments can be accomplished by any method known to the art that creates ion-exchange capable sites and/or enhances the porosity of a coal feed (see, for example, previously incorporated US4468231 and GB1599932). Often, pre-treatment is accomplished in an oxidative manner using any oxidant known to the art.

[0079] In one example, coal is typically wet ground and sized (*e.g.*, to a particle size distribution of about 25 to 2500 microns) and then drained of its free water (*i.e.*, dewatered) to a wet cake consistency. Examples of suitable methods for the wet grinding, sizing, and dewatering are known to those skilled in the art; for example, see previously incorporated US Patent Application No. 12/178,380.

[0080] Any methods known to those skilled in the art can be used to associate one or more gasification catalysts with the carbonaceous material. Such methods include but are not

limited to, admixing with a solid catalyst source, impregnating the catalyst on to the carbonaceous material particulate, incipient wetness impregnation, evaporative impregnation, vacuum impregnation, dip impregnation, and combinations of these methods. Gasification catalysts can be impregnated into the carbonaceous materials (*i.e.*, particulate) by slurring with a solution (*e.g.*, aqueous) of the catalyst.

[0081] The carbonaceous material particulate can be treated to associate at least a first catalyst (*e.g.*, gasification catalyst) therewith, providing the second carbonaceous feedstock. In some cases, a second catalyst (*e.g.*, co-catalyst) can be provided; in such instances, the particulate can be treated in separate processing steps to provide the first catalyst and second catalysts. For example, the primary gasification catalyst can be supplied (*e.g.*, a potassium and/or sodium source), followed by a separate treatment to provide a co-catalyst source. Alternatively, the first and second catalysts can be provided as a mixture in a single treatment.

[0082] One particular method suitable for combining coals with the gasification catalysts and optional co-catalysts to provide a particulate composition where the various components have been associated with the coal particulate via ion exchange is described in previously incorporated US Patent Application Serial No. 12/178,380. The ion exchange loading mechanism is maximized (based on adsorption isotherms specifically developed for the coal), and the additional catalyst retained on wet including those inside the pores is controlled so that the total catalyst target value is obtained in a controlled manner. Such loading provides a particulate composition as a wet cake. The catalyst loaded and dewatered wet coal cake typically contains, for example, about 50% moisture. The total amount of catalyst loaded is controlled by controlling the concentration of catalyst components in the solution, as well as the contact time, temperature and method, as can be readily determined by those of ordinary skill in the relevant art based on the characteristics of the starting coal.

[0083] Additional particulates derived from carbonaceous materials can be combined with the second carbonaceous feedstock prior to introduction into the catalytic gasification reactor by any methods known to those skilled in the art. For example, a second carbonaceous feedstock comprising a coal particulate and a gasification catalyst can be combined with biomass. Such methods include, but are not limited to, kneading, and vertical or horizontal mixers, for example, single or twin screw, ribbon, or drum mixers. The second carbonaceous feedstock (405) can be stored for future use or transferred to a feed operation for introduction into a gasification reactor. The second carbonaceous feedstock (405) can be conveyed to

storage or feed operations according to any methods known to those skilled in the art, for example, a screw conveyer or pneumatic transport.

Examples

Example 1

Catalyzed and Slurry Feedstock Preparation

[0084] As-received coal (Powder River Basin) can be stage-crushed to maximize the amount of material having particle sizes ranging from about 0.85 to about 1.4 mm. Fines (< 0.85 mm) are separated from the crushed materials by vibratory screening and directed to the steam generating combustion reactor.

[0085] The crushed coal would be slurried with an aqueous solution of potassium carbonate, dewatered, and dried via a fluid bed slurry drier to typically yield a catalyzed feedstock containing 185 lb coal (88 wt%), 14.9 lb catalyst (7 wt%), and 10.5 lb moisture (5 wt%). The coal fines separated at the crushing stage can be used as the feedstock for combustion reactor for the preparation of steam.

Example 2

Catalytic Gasification

[0086] The fines of Example 1 can be provided to a combustion reactor fed by an enriched oxygen source. The resulting exhaust gas from the combustion reactor would contain hot CO₂. The exhaust gas can be passed through a heat exchange in contact with a water source to produce steam. The generated steam and the exhaust gas from the combustion reactor can be superheated and then introduced to a fluidized bed gasification reactor (catalytic gasifier) supplied with the catalyzed feedstock of Example 1. The catalyzed feedstock is introduced under a positive pressure of nitrogen. Typical conditions for the catalytic gasifier would be: total pressure, 500 psi and temperature, 1200°F. The effluent of the catalytic gasifier would contain methane, CO₂, H₂, CO, water, H₂S, ammonia, and nitrogen, which is passed to a scrubber to remove ammonia and an acid gas removal unit to remove H₂S and CO₂. The CO₂ can then be recovered.

We claim:

1. A process for generating steam and a plurality of gaseous products from a carbonaceous feedstock and recovering carbon dioxide, characterized in that the process comprises the steps of:

(a) supplying a first carbonaceous feedstock to a reactor, the reactor in communication with a gasifier;

(b) at least partially combusting first carbonaceous feedstock in the reactor to generate (i) heat energy and (ii) a first gas stream comprising carbon dioxide;

(c) utilizing the heat energy to generate steam;

(d) introducing at least a portion of the steam, the first gas stream, a second carbonaceous feedstock, and an alkali metal gasification catalyst to a gasifier;

(e) reacting the second carbonaceous feedstock in the gasifier in the presence of the steam and the alkali metal gasification catalyst and under suitable temperature and pressure to form a second gas stream comprising a plurality of gaseous products comprising methane, carbon dioxide and at least one or more of hydrogen, carbon monoxide, hydrogen sulfide, ammonia and other higher hydrocarbons;

(f) at least partially separating the plurality of gaseous products to produce (i) a third gas stream comprising carbon dioxide and (ii) a fourth gas stream comprising a predominant amount of one of the gaseous products other than carbon dioxide;

(g) recovering the third gas stream; and

(h) recovering the fourth gas stream,

wherein the third gas stream includes carbon dioxide formed in steps (b) and (e).

2. The process of claim 1, characterized in that the third gas stream includes substantially all of the carbon dioxide formed in steps (b) and (e).

3. A process for generating steam, electricity and a plurality of gaseous products from carbonaceous feedstock and recovering carbon dioxide, characterized in that the process comprising the steps of:

(a) supplying a first carbonaceous feedstock to a reactor, the reactor in communication with a gasifier;

(b) at least partially combusting first carbonaceous feedstock in the reactor to generate (i) heat energy and (ii) a first gas stream comprising carbon dioxide;

(c) contacting water with the heat energy to generate steam;

(d) dividing the steam into a first steam stream and a second steam stream;

(e) introducing the first steam stream, the first gas stream, a second carbonaceous feedstock, and an alkali metal gasification catalyst to a gasifier;

(f) introducing the second steam stream to a steam turbine to generate electricity;

(g) reacting the second carbonaceous feedstock in the gasifier in the presence of the steam and the alkali metal gasification catalyst and under suitable temperature and pressure to form a second gas stream comprising a plurality of gaseous products comprising methane, carbon dioxide and at least one or more of hydrogen, carbon monoxide, hydrogen sulfide, ammonia and other higher hydrocarbons;

(h) at least partially separating the plurality of gaseous products to produce (i) a third gas stream comprising carbon dioxide and (ii) a fourth gas stream comprising a predominant amount of one of the gaseous products other than carbon dioxide;

(i) recovering the third gas stream; and

(j) recovering the fourth gas stream,

wherein the third gas stream includes carbon dioxide formed in steps (b) and (g).

4. The process of claim 3, characterized in that the third gas stream includes substantially all of the carbon dioxide formed in steps (b) and (g).

5. The process of any of claims 1-4, characterized in that the first carbonaceous feedstock is in a form of an aqueous slurry.
6. The process of any of claims 1-5, characterized in that the first, second or both carbonaceous feedstocks comprise biomass.
7. The process of any of claims 1-6, characterized in that the first gas stream further comprises carbon monoxide and hydrogen.
8. The process of any of claims 1-7, characterized in that the reactor is a gasifier or an oxygen combuster.
9. The process of any of claims 1-8, characterized in that the gasification catalyst comprises a source of at least one alkali metal and is present in an amount sufficient to provide, in the biomass feedstock, a ratio of alkali metal atoms to carbon atoms ranging from 0.01 to about 0.08.
10. The process of any of claims 1-9, characterized in that the fourth gas stream comprises a predominant amount of methane.

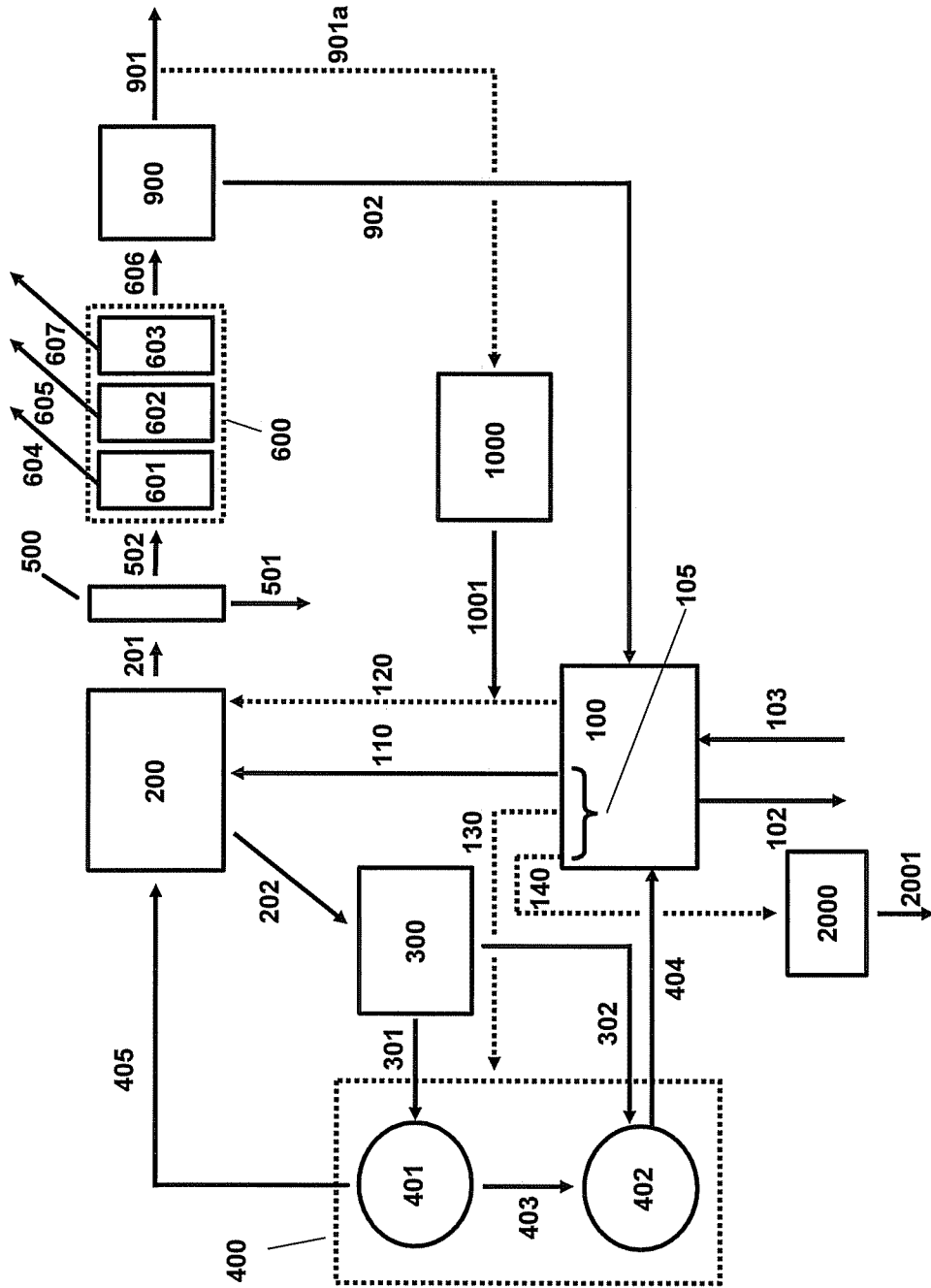

FIGURE 1