

March 14, 1950

A. S. FENEMORE

2,500,532

COOLING MEANS FOR MACHINES

Filed Aug. 21, 1947

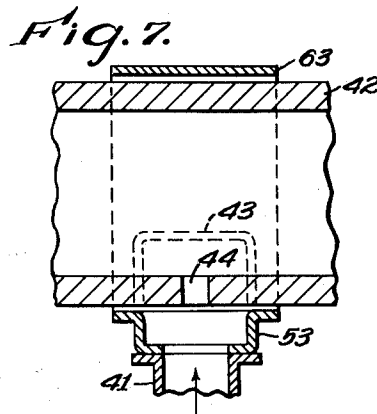
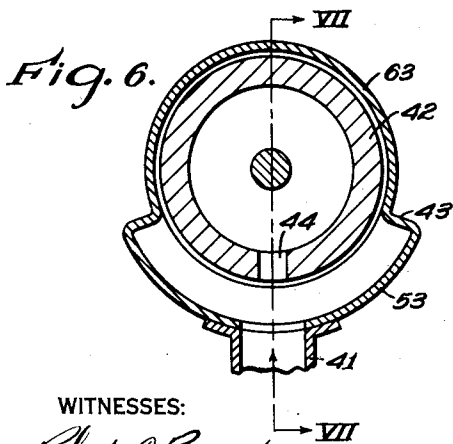
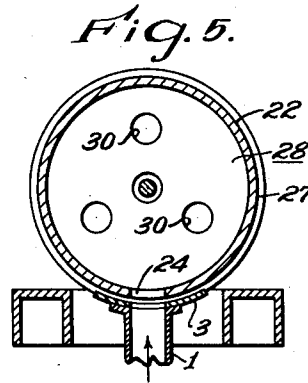
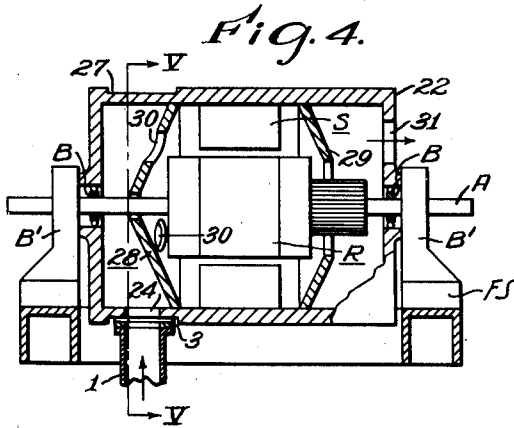
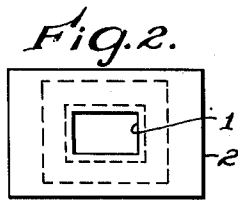
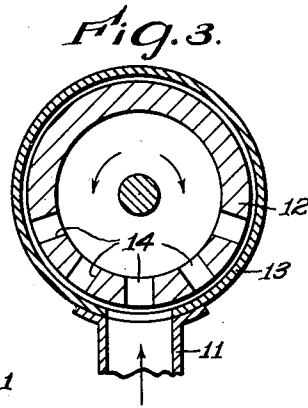
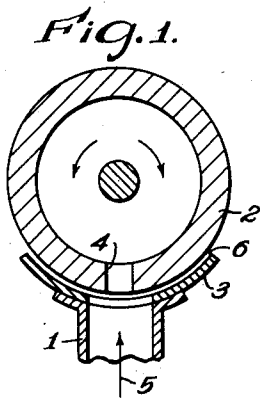

WITNESSES:

Robert C. Baird
Wm. L. Gonne

INVENTOR

Alan S. Fenemore.

BY

Paul E. Friedmann
 ATTORNEY

UNITED STATES PATENT OFFICE

2,500,532

COOLING MEANS FOR MACHINES

Alan Stephen Fenemore, Stafford, England, assignor to The English Electric Company, Limited, London, England, a British company

Application August 21, 1947, Serial No. 769,905
In Great Britain July 29, 1941

Section 1, Public Law 690, August 8, 1946
Patent expires July 29, 1961

3 Claims. (Cl. 172—285)

1

My invention relates to apparatus for ventilating machines and more particularly to apparatus for more effectively ventilating and thus cooling dynamo-electric machines used as swinging frame dynamometers.

One broad object of my invention is the provision of ventilating apparatus for enclosed machines that shall be reliable, inexpensive, and efficient, and that does not require the designing and building of ventilating apparatus into the machine itself.

Another broad object of my invention is the provision of apparatus for ventilating a dynamo-electric machine used as a swinging frame dynamometer.

A somewhat more specific object of my invention is the provision of moving cooling air to the interior of a swinging frame dynamometer from an outside source in such manner that no appreciable drag is imposed on the movement of the frame or in any other manner interfering with the swinging movement of the frame.

The objects stated are merely illustrative of the objects of my invention. Other objects will become more readily apparent from a study of the following specification and the accompanying drawing, in which:

Fig. 1 is a transverse sectional view showing the application of the cooling air to the swinging frame of a dynamometer;

Fig. 2 is a plan view of the air supply shoe and opening for the dynamometer frame;

Fig. 3 is a view corresponding to Fig. 1 of a modification of my invention;

Fig. 4 is a longitudinal sectional view showing a form of my invention applied to a dynamo-electric machine;

Fig. 5 is a view of a transverse section, on line V—V of Fig. 4;

Fig. 6 is a transverse sectional view of modified construction of my invention; and

Fig. 7 is a longitudinal sectional view, on line VII—VII of Fig. 6.

In Fig. 1, I show the supply conduit 1, for supplying cooling air to the interior of the swinging frame 2, provided with the shoe 3 conforming to the contour of the cylindrical outer surface of the frame 2. The cylindrical swinging frame 1 is provided with an opening 4 registering with the axial region of the supply conduit. The disposition of the shoe 3 with reference to the frame 2 is such that only a relatively small radial airgap is provided between the two parts 2 and 3. Cooling air flowing, under some pressure, from conduit 1 in the direction indicated by the arrow 5 will thus

2

enter the opening 4 and only a relatively small leakage will take place at the radial airgap 5. The circumferential extent of the opening of conduit 1 is so chosen, for the usual angular swing of dynamometer frames, that the swinging of the frame 2 will not cause opening 4 to move out of registry with the opening of conduit 1.

When the swing of the dynamometer frame, as frame 12, is through some considerable angle from a neutral position, then I provide the frame 12 with several openings 14 circumferentially spaced as shown in Fig. 3, and I extend the shoe portion for conduit 11 into a complete belt 13 encircling the frame 12.

In Fig. 4 I show my invention, of the form shown in Figs. 1 and 2, applied to a dynamo-electric machine used as a dynamometer. The rotor R is mounted on the arbor A disposed to rotate in the bearings B disposed in the frame 22. The frame 22 is mounted for rotation in bearings B' in the frame structure FS of the dynamometer.

The shoe 3 is disposed within the groove 27. The shoe 3, by being thus disposed in the groove 27, more effectively directs the cooling air from conduit 1 into the frame 22. In order to eliminate the possibility of the cooling air affecting the indications of the dynamometer by improper flow of the air through the frame 7 provide the frame 22 with baffles 28 and 29.

The baffle 28 is provided with a plurality of holes that do not match the opening 24. The cooling air entering the frame 22 is thus evenly distributed in the left end of the frame 22 and thus flows substantially uniformly through the openings 30, over the rotor R and through the stator S to the region of baffle 29. This assures that the cooling air flows over the commutator and then out through the openings 31.

When the angular dynamometer frame movement is large and it is not feasible, or desirable to use the construction shown in Figs. 1 to 5 inclusive then the type of structure shown in Figs. 6 and 7 may be utilized.

In the structure shown in Figs. 6 and 7, the frame 42 is provided with a single opening 44, but the conduit 41 is provided with a shoe portion 43 that is in the form of a hood 53 disposed over a circumferential sector of the frame 42 and in the form of an encircling belt 53 over the remaining portion of the circumference of the frame 42.

While I have discussed but a few embodiments of my invention, it is apparent that others, once having had the benefit of my teachings, may devise similar apparatus. I, therefore, do not wish

3

to be limited to the particular embodiments shown but wish to be limited only by the scope of the claims hereto appended.

I claim as my invention:

1. In combination with a swinging frame type dynamometer, a cylindrical frame mounted for angular movement about its axis, said cylindrical frame being provided with a radial inlet opening in the cylindrical surface near one end of the frame, and provided with an axially disposed opening in the end remote from the end provided with the radial inlet, and conduit means provided with a shoe sector encompassing a portion of the cylindrical frame over the radial opening, whereby cooling air flowing in the conduit means toward the frame will enter said cylindrical frame through the radial inlet and emerge from the frame through the axially disposed opening.

2. In a ventilating system for a dynamo-electric swinging frame type dynamometer, in combination, a base, a swinging frame, having a cylindrical surface at least at one region thereof, mounted for swinging movement in the base, said frame carrying the armature of a dynamo-electric machine, a rotor for the dynamo-electric machine mounted for rotation on the frame, a supply conduit for supplying cooling air to the interior of the frame, a shoe on the conduit end, said shoe being disposed to encircle a selected arcuate portion of the cylindrical surface to provide a relatively small radial airgap between the shoe and frame, said frame being provided with an opening in registry with the conduit, and another opening remote from the first opening for discharging the cooling air supplied by the conduit to the swinging frame.

4

3. In a ventilating system, in combination, a base, a cylindrical container having a radial opening in the cylindrical surface for receiving ventilating air and an opening at one end thereof for discharging the ventilating air, bearings in the base for the container so that the container is rotatably mounted with reference to the base, a conduit mounted in fixed relation to the base and disposed so that the end thereof is in registry with the radial opening in the container when the container is in its normal position, and a hood secured to the end of the conduit for directing the cooling air into the radial opening even though the container moves from its normal position.

ALAN STEPHEN FENEMORE.

REFERENCES CITED

The following references are of record in the file of this patent:

UNITED STATES PATENTS

Number	Name	Date
1,118,215	Mossman	Nov. 24, 1914
1,451,577	Jantzen	Apr. 10, 1923
1,523,322	Marret	Jan. 20, 1925
1,750,873	Buck	Mar. 18, 1930
1,805,332	Goss	May 12, 1931
2,057,637	Schneider	Oct. 13, 1936
2,351,963	Hayes	June 20, 1944
2,352,317	Goff	June 27, 1944

FOREIGN PATENTS

Number	Country	Date
494,497	Great Britain	Oct. 26, 1938