



## INTERNATIONAL APPLICATION PUBLISHED UNDER THE PATENT COOPERATION TREATY (PCT)

<p>(51) International Patent Classification <sup>6</sup> : <b>A61M 29/02, 25/00</b></p>	<p><b>A2</b></p>	<p>(11) International Publication Number: <b>WO 95/18647</b></p> <p>(43) International Publication Date: 13 July 1995 (13.07.95)</p>
<p>(21) International Application Number: PCT/US94/14970</p> <p>(22) International Filing Date: 27 December 1994 (27.12.94)</p> <p>(30) Priority Data: 08/177,911 6 January 1994 (06.01.94) US</p> <p>(71) Applicant (for all designated States except US): SCIMED LIFE SYSTEMS, INC. [US/US]; One Scimed Place, Maple Grove, MN 55311-1566 (US).</p> <p>(72) Inventors; and (75) Inventors/Applicants (for US only): RAU, Bruce, H. [US/US]; 14186 Grover Avenue N.W., Clearwater, MN 55320 (US). SHOEMAKER, Susan, M. [US/US]; 11106 - 190th Avenue N.W., Elk River, MN 55330 (US). BUSCEMI, Paul, J. [US/US]; 2310 Tamarack Drive, Long Lake, MN 55356 (US).</p> <p>(74) Agents: BRENNAN, Leoniede, M. et al.; Suite 1540, 920 Second Avenue South, Minneapolis, MN 55402 (US).</p>		<p>(81) Designated States: CA, JP, US, European patent (AT, BE, CH, DE, DK, ES, FR, GB, GR, IE, IT, LU, MC, NL, PT, SE).</p> <p><b>Published</b> <i>Without international search report and to be republished upon receipt of that report.</i></p>
<p>(54) Title: THERMOPLASTIC POLYIMIDE BALLOON CATHETER</p>		
<p>(57) Abstract</p> <p>The present invention discloses the incorporation of thermoplastic polyimide into various parts of balloon catheters such as catheter shafts and balloons. Such catheter construction may be integral or unitary in which the shaft or a portion thereof and balloon are manufactured as a single unit or the construction may be comprised of a separate shaft to which a balloon is attached, as by adhesive or other bonding.</p>		

**FOR THE PURPOSES OF INFORMATION ONLY**

Codes used to identify States party to the PCT on the front pages of pamphlets publishing international applications under the PCT.

AT	Austria	GB	United Kingdom	MR	Mauritania
AU	Australia	GE	Georgia	MW	Malawi
BB	Barbados	GN	Guinea	NE	Niger
BE	Belgium	GR	Greece	NL	Netherlands
BF	Burkina Faso	HU	Hungary	NO	Norway
BG	Bulgaria	IE	Ireland	NZ	New Zealand
BJ	Benin	IT	Italy	PL	Poland
BR	Brazil	JP	Japan	PT	Portugal
BY	Belarus	KE	Kenya	RO	Romania
CA	Canada	KG	Kyrgyzstan	RU	Russian Federation
CF	Central African Republic	KP	Democratic People's Republic of Korea	SD	Sudan
CG	Congo	KR	Republic of Korea	SE	Sweden
CH	Switzerland	KZ	Kazakhstan	SI	Slovenia
CI	Côte d'Ivoire	LI	Liechtenstein	SK	Slovakia
CM	Cameroon	LK	Sri Lanka	SN	Senegal
CN	China	LU	Luxembourg	TD	Chad
CS	Czechoslovakia	LV	Latvia	TG	Togo
CZ	Czech Republic	MC	Monaco	TJ	Tajikistan
DE	Germany	MD	Republic of Moldova	TT	Trinidad and Tobago
DK	Denmark	MG	Madagascar	UA	Ukraine
ES	Spain	ML	Mali	US	United States of America
FI	Finland	MN	Mongolia	UZ	Uzbekistan
FR	France			VN	Viet Nam
GA	Gabon				

## Termoplastic polyimide Balloon catheter

Background of the Invention

This invention relates to dilation balloon catheters, particularly  
5 those used in angioplasty. More specifically, it relates to the balloons on such  
catheters and to some extent to the catheter shaft as well. Angioplasty relates  
to opening of stenoses in the vascular system usually by means of a catheter  
having a balloon at its distal end. Such catheters may be single or multiple  
lumen, may be over-the-wire or non-over-the-wire. Very similar catheters  
10 may be used for placing stents. All such catheters are referred to herein  
collectively as "balloon catheters". The invention described herein could also  
be utilized in the production and manufacture of guide catheters or infusion  
catheters.

It is possible to make balloons from a variety of materials that  
15 are generally of the thermoplastic polymeric type. Such materials may  
include: polyethylenes and ionomers, ethylene-butylene-styrene block  
copolymers blended with low molecular weight polystyrene and, optionally,  
polypropylene, and similar compositions substituting butadiene or isoprene in  
place of the ethylene and butylene; poly(vinyl chloride); polyurethanes;  
20 copolyesters; thermoplastic rubbers; siliconopolycarbonate copolymers; and  
ethylene-vinyl acetate copolymers.

One material of choice for such catheters has been thermoset  
polyimide, primarily because of its high strength and flexibility in small  
diameter with very thin walls. Being thermoset, the polyimide used heretofore  
25 has involved complicated manufacturing procedures due to the fact that it is  
insoluble and "intractable" i.e., not meltable. For example, in forming  
catheter shafts, it has been necessary to build up the shaft with multiple layers  
of polyimide on a substrate which is subsequently dissolved away. This has  
also been necessary in making the catheter balloon in which multiple layers of

-2-

thermoset polyimide were layered onto a form, of glass for example, which was later etched away leaving a polyimide balloon.

This type of polyimide is a heterochain polymer typically made of two base monomers, a diamine and a dianhydride (e.g. para-aminoaniline and pyromellitic dianhydride). Such polyimide is typically formed by two step  
5 reaction like the following example. First, a polyamide is formed from the monomers. The reaction proceeds at about 25° C. and the product is soluble and stable in very polar solvents. Second, the polyamide is condensed to polyimide at about 120° C. Further description of polyimides and their  
10 preparation can be found in Androva et al. *Polyimide, A New Class of Heat-Resistant Polymers*, pp. 4-13 (1969).

As already indicated other plastics have been used in catheter construction for shafts and balloons in which the plastic has been of the thermoplastic type. For example, polyethylene terephthalate (PET) has been  
15 used to make the balloons. Thermoplastic materials lend themselves to simpler manufacturing techniques, such as extrusion in forming shafts and blow molding in forming the balloons than do the aforementioned thermoset polyimide materials due to the fact that they are soluble and meltable. However, the art has failed to recognize that thermoplastic polyimide is  
20 available for balloon catheter construction.

Although many of the procedures employing balloon catheters are still in the experimental stage in the United States, there is a considerable amount of art available on the formation and use of balloon catheters. Illustrations of such art are: U.S. Patent Nos. 4,952,357 to Euteneuer;  
25 4,413,989 and 4,456,000 to Schjeldahl et al. and 4,490,421 as well as Reissue Patent Nos. 32,983 and 33,561 to Levy.

The Euteneuer patent relates to the prior art polyimide catheter/balloon construction. The Schjeldahl patents, incorporated herein by reference, pertain to catheter assemblies or attachments. These patents

-3-

disclose expanders (balloons) formed from a thin, flexible, inelastic, high tensile strength, biaxially oriented, synthetic plastic material. The Levy patents, which issued several years after the Schjeldahl patents, sought to provide balloons exhibiting physical properties superior to those exhibited by prior art balloons. The specific qualities Levy emphasized were toughness, flexibility and tensile strength. Levy teaches that a high tensile strength balloon can only be formed from a high intrinsic viscosity polymer, specifically, high molecular weight polyethylene terephthalate.

High tensile strengths are important in angioplasty balloons because they allow for the use of high pressure in a balloon having a relatively small wall thickness. High pressure is often needed to treat some forms of stenosis. Small wall thicknesses enable the deflated balloon to remain narrow, making it easier to advance the balloon through the arterial system.

#### 15 Summary of the Invention

It is the primary purpose of this invention to apply thermoplastic polyimide to the art of balloon catheter construction, i.e., to catheter shafts and balloons. It is another purpose of this invention to apply thermoplastic polyimide to the art of guide catheter construction and infusion catheter construction. Such catheter construction may be either integral or unitary in which the shaft or a portion thereof and balloon are manufactured as a single unit or the construction may be comprised of a separate shaft to which a balloon is attached, as by adhesive or other bonding.

#### 25 Brief Description of the Drawings

A detailed description of the invention is hereafter described with specific reference being made to the drawings in which:

FIG. 1 is a schematic; somewhat idealized view of a balloon catheter using thermoplastic polyimide according to the invention in both shaft

and balloon portions.

FIG. 2 is a partial sectional view of the distal portion of the catheter shown comprising a longitudinal cross-sectional view of the balloon of FIG. 1.

5                FIGS. 3 and 4 are enlarged cross-sectional views of portions of a wall of a balloon having a plurality of layers forming the wall i.e., a composite of thermoset and thermoplastic polyimide.

FIG. 5 is a front view, with portions broken away, showing a shaft of the catheter of FIG. 1 which is a polyimide shaft with braided  
10    reinforcement;

FIG. 6 is a cross-sectional view of the shaft of FIG. 5 taken on line 6-6 of FIG. 5;

FIG. 7A is a cross-sectional view of a shaft according to the present invention, wherein the shaft has a reinforcement at its innermost  
15    diameter and a polyimide coating over the reinforcement structure;

FIG. 7B is a cross-sectional view of a shaft according to the present invention comprising a thermoplastic polyimide material surrounding a reinforcement material;

FIG. 8 is a cross-sectional view of a shaft according to the present invention, wherein the shaft has a reinforcement material embedded in  
20    the outermost diameter of the polyimide substrate;

FIG. 9 is a cross-sectional view of a shaft according to the present invention, wherein the shaft has a reinforcement material at its innermost diameter with polyimide coating the reinforcement structure;

25                FIG. 10 is a cross-sectional view of a shaft according to the present invention, wherein the shaft is formed from a blend of polyimide and a reinforcing material;

FIG. 11 is a cross-sectional view of a shaft according to the present invention, wherein the shaft is formed of a fluoropolymer at the inner

-5-

diameter, a layer of polyimide surrounding the fluoropolymer layer and a reinforcement material bonded to or embedded in the polyimide layer;

FIG. 12 is a cross-sectional view of a shaft according to the present invention, wherein said shaft is formed of a polyimide inner layer, an  
5 intermediate reinforcing material and an outer polyimide layer;

FIG. 13 is a cross-sectional view of a shaft according to the present invention, wherein said shaft is formed from a coextruded shaft having a polyimide/liquid crystal polymer blend surrounding its inner diameter and polyimide surrounding its outer diameter;

10 FIG. 14 is a cross-sectional view of a shaft according to the present invention, wherein said shaft is formed from a coextruded shaft having a polyimide/liquid crystal polymer blend surrounding its outer diameter and polyimide surrounding its inner diameter;

15 FIG. 15 is a cross-sectional view of a shaft according to the present invention having an inner layer of polytetrafluoroethylene surrounded by an outer layer comprising thermoplastic polyimide or a thermoplastic polyimide blend;

20 FIG. 16 is a cross-sectional view of a shaft according to the present invention comprising inner and outer layers of polyimide surrounding an intermediate layer comprising a blend; and

FIG. 17 is a partial sectional view of the shaft of a catheter according to the present invention.

#### Description of the Preferred Embodiments

25 The invention lies in a high strength, thin walled, balloon, and in some instances the catheter shaft or portions thereof, formed from a thermoplastic polyimide. The invention also encompasses the process for manufacturing such a balloon and/or catheter shaft, and could also be utilized in the production and manufacture of guide catheters or infusion catheters.

-6-

A balloon of this invention is preferably obtained by extruding thermoplastic polyimide tubing and then expanding the extruded tubing axially and radially. Any conventional extruder may be employed to perform the extrusion process.

5                   Figure 1 shows a schematic view of a balloon catheter, shown generally at 10. Catheter 10 has an elongated flexible shaft 12 which according to the invention, may at least in part, be comprised of thermoplastic polyimide. That is, the entire length thereof may consist of thermoplastic polyimide or a longitudinal section or sections thereof may consist of  
10 thermoplastic polyimide or it may be entirely of another material with only the balloon being of thermoplastic polyimide. Since it is thermoplastic at least in part, shaft 12 may be formed by tubular extrusion as is the case of the techniques known in this art for extruding other thermoplastic materials such as the PET aforementioned and as already described hereinabove. In a preferred  
15 embodiment of the present invention, thermoplastic polyimide is present in both shaft and balloon portions.

Mounted at the distal end of catheter 10, shown in the lower portion of Figure 1, which is enlarged to show detail, shaft 12 is fitted with an inflatable thin wall balloon generally designated at 14 (shown inflated).  
20 Depending on the particular construction of the catheter, the distal tip 16 may be the distal end of a guide wire as shown or it may be the distal end of the catheter per se.

Shaft 12 has at least one lumen (not shown) extending from its proximal to its distal end. Depending on its construction, multiple lumens may  
25 be provided. In any case, at least an inflation lumen extends through shaft 12 for selective inflation and deflation of balloon 14. Any or all of the lumens may be made from thermoplastic polyimide.

Balloon 14 is a thin wall thermoplastic polyimide balloon formed in the art known manner by blow molding as described above. This technique



-7-

is also discussed in the aforementioned United States Patent 4,490,421 for forming PET balloons. As seen in Figure 1, a balloon in one embodiment comprises a proximal waist portion 18 bonded to the distal end of shaft 12, an intermediate inflatable body portion 20 of a larger diameter than waist 18, and  
5 a smaller distal end portion 22.

Thermoplastic polyimide is a linear aromatic polyimide first developed by NASA and described in *NASA Conf. Pub. #2334 (1984)* at pp. 337-355, entitled *THERMOPLASTIC/MELT-PROCESSABLE POLYIMIDES*, authored by T.L. St. Clair and H.D. Burks.

-8-

The structural formula is shown as follows:

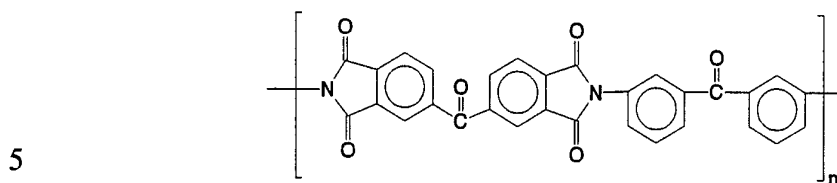

Also shown in that reference is a polyimide sulfone:

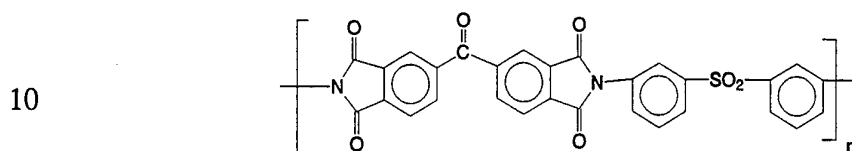

and is a polyphenylene ethersulfideimide:

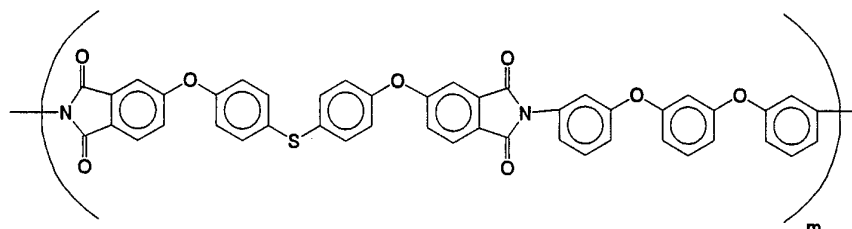

Any of the above examples of polyimides may be used according to this invention.

One such thermoplastic polyimide is available commercially under the tradename AURUM<sup>®</sup> from Mitsui Toatsu Chemicals, Inc., of Tokyo,



-10-

polyimide decomposes at a temperature range above about 400°-410°C. The softening temperature of thermoplastic polyimide is about 320°-380°C, and the melting temperature is about 340-410°C. The physical properties of thermoplastic polyimide offer the opportunity of secondary forming operations.

5 For example, the material as extruded tubing can be reheated and a balloon can be blown out of it. Thermoplastic can be remelted. Scrap can be ground up and run through an extruder again. Thermoset polyimide cross links upon curing, which precludes the possibility of remelting for reuse or recycling.

10 There is a tendency for the fracture mode upon failure of prior art thermoset polyimide balloons to be more of a catastrophic fracture rather than the preferred longitudinal burst mode of thermoplastic polyimide balloons of the invention. For this reason, an alternate embodiment of the invention with respect to balloon construction may comprise a multiple layer balloon of the type shown in Figures 2 - 4. This balloon generally designated 30 is  
15 comprised of a blow molded balloon of thermoplastic polyimide having a deposited outer layer 34 of prior art thermoset polyimide, polyamide, or any other material laid down in the known manner on the inflated thermoplastic polyimide 32 of the balloon. Such construction provides a balloon having predominantly longitudinal burst characteristics. This embodiment also offers  
20 one the opportunity of tailoring the compliance characteristics of the balloon by selectively altering the number, arrangement and thickness of these layers in a variety of configurations. Moreover, the thermoplastic polyimide balloons of the invention may have no outer layer at all or they may carry a single outer layer or multiple outer layers (full or partial) of extruded thermoplastic  
25 polyimide or other polymer materials for layer 34.

In manufacturing the balloons of the invention, techniques and tools utilized in the prior art for thermoplastic balloons are readily adaptable.

Considering all of the foregoing, thermoplastic polyimide balloons may be readily manufactured which have, for example, diameters of

-11-

about 1.5 - 25mm, lengths of about 5 - 200mm, wall thicknesses of about 0.0003 - 0.003 inches and to any of the typical ranges for balloon dimensions and strengths as typically utilized in the medical industry heretofore. The minimum length is from about 5mm to about 10mm, and the most preferred  
5 length is about 20mm in length.

#### EXTRUSION OF THERMOPLASTIC POLYIMIDE

The drying and extrusion equipment must be thoroughly clean and dry to reduce possibility of material contamination. It is important to sufficiently pre-dry the resin prior to extrusion to prevent creation of surface  
10 defects caused by moisture. The resin can be dried by a desiccant type hot air dryer using -40F dew point air in a plenum style hopper. The moisture content of the polyimide is controlled to less than 100ppm by varying both drying temperature and time. Polyimide resin dried at a temperature of 180C in excess of 10 hours provides desired moisture levels. An extruder with a  
15 length to diameter ratio of about 25:1 and a minimum of three barrel temperature control zones with additional heater control zones for adapter, head and die is adequate. Temperature controllers are proportioning type in order to maintain tight temperature control and a homogeneous melt. Both barrel and screw of the extruder are made of conventional bimetallic material  
20 that is surface hardened and chrome plated. Conventional nitride metals tend to degrade by oxidation which causes the generation of black rust at high temperatures. A preferred screw for the extruder is a Barrior design having a length to diameter ratio of from 18 to 28:1 and a compression ratio of 2.7:1 with a zone distribution of about 25% feed, 46% compression, and 30%  
25 metering. General purpose screw with 2.5 to 3.5:1 compression ratios and a relatively constant transition from feed to metering zone have also worked effectively. Breaker plate, adapter, head, and tooling are hard chrome plated and streamlined, i.e., gradual transitions, rounded edges and minimal obstructions. Screen packs with a micron rating of 40 to 80 mesh having

-12-

stainless steel gauge construction are generally sufficient to generate adequate back pressure. Die and tip cross-sectional area drawdown ratios (which is the area defined by the die and mandrel divided by the cross-sectional area of the extruded tubing) can range from 3 to 30:1, and die land lengths range from 10 to 60 times the desired product wall thickness. Sizing can be accomplished by free extrusion methods, maintaining constant nitrogen pressure inside the tubing while being quenched in a conventional water bath at ambient temperatures.

The pre-dried thermoplastic polyimide pellets are preferably delivered to the feed throat of an extruder from a plenum style/hopper, and conveyed forward through several heating zones by rotating the extruder screw. Melt temperature of the polyimide is maintained from 340C to 410C by the various zone temperature controllers, and by shear generated from the action of a 3/4 or 1 1/4 inch diameter screw rotating at speeds ranging from 2 to 50 RPM. The material then passes through a screen pack, breaker plate, adapter, tooling head, and extrusion tooling where it is shaped to form the desired product. Optimally, the residence time in the extruder is kept to a minimum. Once the material exits the tooling in its desired form, it needs to be cooled. One way to perform the cooling process is to pass the extruded tubing from the extruder, through an air gap between tooling and quench tank ranging from 0.25 to 25 inches, and into a water bath maintained at a temperature ranging from 40F to 120F. A haul-off may be used to pull the tube from the cooled end through the quench tank. Thereafter, the product is spooled or cut to length as desired.

25

#### BALLOON FORMING WITH THERMOPLASTIC POLYIMIDE

Some minimal initial orientation of polyimide material is accomplished as the material is drawn down during extrusion. This orientation process is typically known as machine orientation and is formed in the

-13-

direction of extrusion operation. A small amount of additional longitudinal orientation occurs during balloon formation. This additional orientation is the result of the material elongation at blow molding temperatures, and is caused by the weight of the balloon mold stretching the tubing downward at a ratio of

5 1.1 to 3:1 at molding temperatures ranging from 230C to 330C. The preferred longitudinal stretch time at molding temperatures is from 8 to 10 minutes. Method improvements to optimize stretching and heating will probably reduce stretch times. Once the optimum longitudinal stretch is achieved, the tubing is expanded radially using internal pressures ranging from 3 to 100 psig.

10 However, the preferred pressure is 20 to 50 psig. This is accomplished by providing a pressurized fluid or gas, preferably nitrogen gas, to the inner lumen of tubing. Tubing extends outside both ends of the mold, one end is clamped off such that no gas can flow through it, and the opposite end is pressurized to form the balloon. An appropriate mold with the tubing inside,

15 may be heated while pressure is applied. The preferred molding temperature ranges from 260C to 300C. The dimensions to which it is stretched are preferably controlled by performing the radial stretching while the tubing is in a mold having the shape of the desired balloon. Suitable molds are known in the art. The tubing subjected to specific interior pressures and exterior heat is

20 held stationary for a period of time, preferably 4 to 6 minutes, while the balloon and waist portions yield completely and stabilize. Method improvements to optimize balloon mold heating will probably result in reduced heat soak cycles. The radial expansion, or hoop ratio (calculated by dividing the inner diameter of the balloon by the inner diameter of the extruded tubing),

25 should be in the range of 3 to 8:1. The preferred hoop ratio is approximately 5:1. The tubing, now comprising the balloon, is next cooled. One way to cool the balloon is to remove the mold from the heat chamber and place it in a cooling bath. The cooling bath is preferably maintained at ambient temperature. The balloon may for example, remain in the cooling bath for

-14-

approximately 10 seconds. However, a chilled bath can be used to reduce the quench cycle times. Finally, the ends of the tubing extending from the mold are cut off (unless integral catheter shaft/balloon construction is intended) and the balloon is removed from the mold by removing either the distal or  
5 proximal end from the body section of the mold, then gently pulling the balloon from the remaining mold sections.

As already indicated, for any given catheter construction, the entire shaft 12 could be polyester, polyethylene, thermoset polyimide or anything else known in the art. The thermoplastic polyimide balloon would be  
10 bonded to such a shaft. On the other hand, the balloon may be integral with the shaft or a portion thereof to provide an all thermoplastic polyimide construction.

The shaft may be composed of a blend of materials. The entire shaft or a portion thereof may be coextruded. For example, a shaft may  
15 include a layer of polytetrafluoroethylene (PTFE) surrounded by thermoplastic polyimide or a blend of thermoplastic polyimide and other polymeric and/or reinforcement components. Such a blend may comprise PTFE or carbon and thermoplastic polyimide. Examples of such blends includes up to about 10% PTFE or about 15 % carbon and a balance of thermoplastic polyimide.  
20 Another blend may include liquid crystal polymer, radiopaque materials such as bismuth salts, tungsten or titanium, silver or gold (which would impart conductivity to the blend). A shaft according to the present invention may include inner and outer layers of thermoplastic polyimide surrounding an intermediate layer comprising a blend as described above.

25 The shaft and/or balloon may be reinforced. The reinforcement material may comprise various types of continuous or intermittent reinforcing components used in the composites of this invention. Among such suitable materials are continuous fiber or filament forms such as polyester, polyamide or carbon fiber, and further may be sphere and particulate forms such as glass.



-15-

Reinforcing material may comprise glass, carbon, ceramic, fluoropolymer, graphite, liquid crystal polymers, polyester, polyamide, stainless steel, titanium and other metals such as nitinol, or radiopaque materials (such as Bismuth or Tungsten) and the like.

5                   The continuous reinforcement may be used in filamentary form or it may be employed in the form of a yarn or as a fabric of plain weave, satin weave, twill weave, basket weave, braid, winding or the like. The composite structure may comprise parallel aligned continuous filaments extending within or along the inner or outermost dimension of the structure,  
10 the fibers being bonded together with the above-described thermoplastic polyimide which intimately contacts substantially the whole of the surfaces of the filaments.

                  Figures 5 - 6 illustrate an alternative embodiment of the shaft, shown generally at 12 of Figure 5. Shaft 12 has a continuous reinforcement in  
15 the form of a tubular braid 52 formed of individual strands 50. Polyimide material 54 encases tubular braid 52 on both the inner and outer surfaces of braid 52. Braid 52 is shown centered in polyimide material 54.

                  Figure 7A illustrates an alternative embodiment of the shaft of the present invention, wherein shaft 12 has a reinforcement at its innermost  
20 diameter and a polyimide coating over the reinforcement structure. Although a braided reinforcement is shown, any continuous or intermittent reinforcement as described herein may be employed. For example, Figure 7B shows a thermoplastic polyimide material 54 surrounding reinforcement material 56 comprising a material such as polyester, polyamide malleable metal or plastic.

25                   Figure 8 illustrates a further alternative embodiment of the shaft of the present invention, wherein shaft 12 has a reinforcement material 50 embedded near the outermost diameter of thermoplastic polyimide substrate 54. Again, although a braided reinforcement material is shown, any reinforcement as described herein may be employed.

-16-

Figure 9-15 illustrate still further embodiments of the shaft of the present invention. Figure 9 shows shaft 12 having reinforcement material 50 at the innermost diameter of thermoplastic polyimide material 54. Reinforcement structure 50 is coated by polyimide material 54, but is almost  
5 exposed.

Figure 10 shows a shaft formed from a blend of polyimide and a reinforcing material. The reinforcement material as shown is in discontinuous form, i.e. dispersed particulate such as glass spheres 60 embedded throughout thermoplastic polyimide material 54. Blends as described hereinabove may be  
10 employed, as may carbon fibers as also described above.

Figure 11 shows shaft 12 formed of an inner layer 62 of a fluoropolymer, a layer of polyimide material 54 surrounding inner layer 62 and a reinforcement material 50 as described hereinabove bonded to or embedded in polyimide material 54. Figure 11 is also an example of a cross  
15 section of a guide catheter according to the present invention. By varying diameter, length and flexibility of the shafts described herein, various medical devices including infusion catheters and guide catheters can be produced.

Figure 12 shows shaft 12 formed of polyimide inner layer 68, intermediate reinforcing material 70 as described hereinabove, and an outer  
20 polyimide layer 72. Figure 13 shows shaft 12 having layer 74 comprising a polyimide/liquid crystal polymer blend layer, surrounded by a layer of polyimide 76. An alternative configuration wherein polyimide/liquid crystal polymer blend layer 74' surrounds polyimide layer 76' is shown at Figure 14.

Liquid crystal polymers are known to the art. Liquid crystal  
25 polymers are rigid, rod-like macromolecules which typically contain a substantial number of polyvalent aromatic groups such as phenylene. After alignment or orientation by shear or elongational forces, the steric hindrance of molecular rotation provided by the polyvalent or other groups causes the liquid crystal polymers to retain their orientation to effect hardening. Examples of

-17-

liquid crystal polymers are VECTRA sold by Hoechst-Celanese, or HX materials sold by DuPont, XYDAR and Econol (terpolymer of hydroxybenzoic acid, biphenol and terephthalic acid) from Dartco and Sumitomo Chemical, respectively, Vecrora from Polyplastic, and Ueno (terpolymer of 2-oxy-6-  
5 naphthoic acid, biphenol, and terephthalic acid) from Ueno Seiyaku, and any other polymer material having a rod like molecule which imparts a tendency to align more readily during melt flow than flexible chain polymers.

The embodiment of shaft 12 shown at Figure 15 includes an inner layer 80 of polytetrafluoroethylene (PTFE) surrounded by an outer layer  
10 82 of thermoplastic polyimide. Outer layer 82 may alternatively be comprised of a blend of thermoplastic polyimide and other components as described hereinabove. A still further embodiment of shaft 12 according to the present invention as shown at Figure 16 may include inner and outer layers 86,88 of thermoplastic polyimide surrounding an intermediate layer 90 comprising a  
15 blend as described above.

A still further embodiment of shaft 12 is shown at Figure 17, where a wire winding type reinforcing material 92 is used within the polyimide to reinforce polyimide material 54.

While this invention may be embodied in many different forms,  
20 there are shown in the drawings and described in detail herein specific preferred embodiments of the invention. The present disclosure is an exemplification of the principles of the invention and is not intended to limit the invention to the particular embodiments illustrated.

This invention has been carefully described herein in order to  
25 provide those skilled in the art with the information necessary to perform the requisite process and obtain the desired product. However, it is to be understood that the invention can be carried out by different techniques and a variety of equipment. Therefore, various known modifications, both as to equipment details and operating procedures, may be incorporated without

-18-

departing from the scope of the invention itself.

This completes the description of the preferred and alternate embodiments of the invention. Those skilled in the art may recognize other equivalents to the specific embodiment described herein which equivalents are  
5 intended to be encompassed by the claims attached hereto.

-19-

## WHAT IS CLAIMED IS:

1. An improved balloon catheter comprising a shaft portion having a proximal end and a distal end, and a balloon portion located at the distal end of said shaft portion, wherein the improvement comprises one of said portions  
5 of the balloon catheter being comprised of thermoplastic polyimide.
2. The balloon catheter of claim 1 in which at least a portion of the shaft is thermoplastic polyimide.
3. The balloon catheter of claim 1 in which the balloon is comprised at least in part of thermoplastic polyimide.
- 10 4. An improved balloon catheter comprising a shaft portion having a proximal end and a distal end, and a balloon portion located at the distal end of said shaft portion, wherein the improvement comprises the balloon portion being comprised of an innermost balloon layer and at least one additional layer, and wherein at least two of said layers are comprised of polyimide, and  
15 one of said polyimide layers is comprised of thermoplastic polyimide.
5. The balloon catheter of claim 4 in which the inner most balloon layer is thermoplastic polyimide.
6. A balloon portion of a balloon catheter wherein the balloon is comprised at least in part of thermoplastic polyimide.
- 20 7. The balloon portion of claim 6 comprised of multiple layers, one of said layers being an innermost layer, wherein at least one of said layers is thermoplastic polyimide.
8. A balloon portion of a balloon catheter, said balloon portion being comprised at least in part of thermoplastic polyimide, and further  
25 comprising at least two layers, one of said layers being an innermost layer, wherein one of said layers is a thermoplastic polyimide, and the other said layer a thermoset polyimide.
9. The balloon portion of claim 8 wherein the innermost layer is thermoplastic polyimide.

-20-

10. A catheter comprising a shaft, said shaft being comprised, at least in part, of thermoplastic polyimide.
11. A balloon catheter comprised of thermoplastic polyimide, said balloon catheter further comprising
- 5 a) a shaft having a proximal end and a distal end; and  
b) a balloon portion projecting from the distal end of said shaft.
12. A catheter comprising:
- 10 a) a shaft having a proximal end and a distal end; and  
b) a balloon portion further comprising:  
i) a proximal waist portion constructed and arranged to be bonded to the distal end of the shaft of the catheter;  
ii) an intermediate body portion of larger diameter than the waist portion;  
15 iii) and a distal end portion of a size smaller than the proximal waist portion,  
said balloon portion being comprised at least in part of thermoplastic polyimide.
13. A catheter comprising:
- 20 a) a shaft having a proximal end and a distal end; and  
b) a balloon portion comprised at least in part of thermoplastic polyimide, said balloon portion further comprising:  
i) a proximal waist portion constructed and arranged to be bonded to the distal end of the shaft of the catheter;  
25 ii) an intermediate inflatable body portion of larger diameter than the waist portion;  
iii) and a distal end portion of a size smaller than the proximal waist portion,  
said balloon portion being comprised of multiple layers, at least one of

-21-

said layers being thermoplastic polyimide.

14. The catheter of claim 12 wherein the balloon portion has a diameter of about 1.5 - 25 mm.
15. The catheter of claim 12 wherein the balloon portion has a wall thickness of about 0.0003 - 0.003 inch.
16. A balloon portion of a balloon catheter, said balloon portion being comprised at least in part of thermoplastic polyimide, and further comprising at least two layers, one of said layers being an innermost layer, wherein one of said layers is a thermoplastic polyimide, and the other said layer is a thermoset polyimide.
17. The balloon portion of claim 16 wherein the innermost layer is thermoplastic polyimide.
18. A balloon portion of a balloon catheter comprised at least in part of thermoplastic polyimide having a melting point between about 340°C - 410°C.
19. The balloon portion of claim 18 comprised of multiple layers, one of said layers being an innermost layer, wherein at least one of said layers is thermoplastic polyimide.
20. A balloon portion of a balloon catheter as in claim 19 wherein one of said layers is thermoplastic polyimide, and the other said layer is thermoset polyimide.
21. The balloon portion of claim 20 wherein the innermost layer is thermoplastic polyimide.
22. A catheter comprising a shaft, said shaft being comprised, at least in part, of thermoplastic polyimide having a melting point between about 340°C - 410°C.
23. The catheter of claim 1 wherein at least a portion of the shaft is comprised of thermoplastic polyimide coextruded with another material.
24. The balloon catheter of claim 1 wherein the shaft and balloon

-22-

are integrally formed.

25. A catheter shaft comprised at least in part of thermoplastic polyimide, said shaft further comprising a reinforcement material.

26. The shaft of claim 25 wherein the reinforcement material is a  
5 braided reinforcement.

27. The shaft of claim 25 wherein the reinforcement is located near an outer diameter of the shaft.

28. The shaft of claim 25 wherein the reinforcement is located near an inner diameter of the shaft.

10 29. The shaft of claim 25 wherein the reinforcement material is a fiber.

30. The shaft of claim 25 wherein the reinforcement material is blended with thermoplastic polyimide.

31. The shaft of claim 25 wherein the reinforcement material is in a  
15 spherical form.

32. The shaft of claim 25 having an inner diameter covered with a fluoropolymer, and wherein the reinforcement material is located in the polyimide material.



Fig. 1

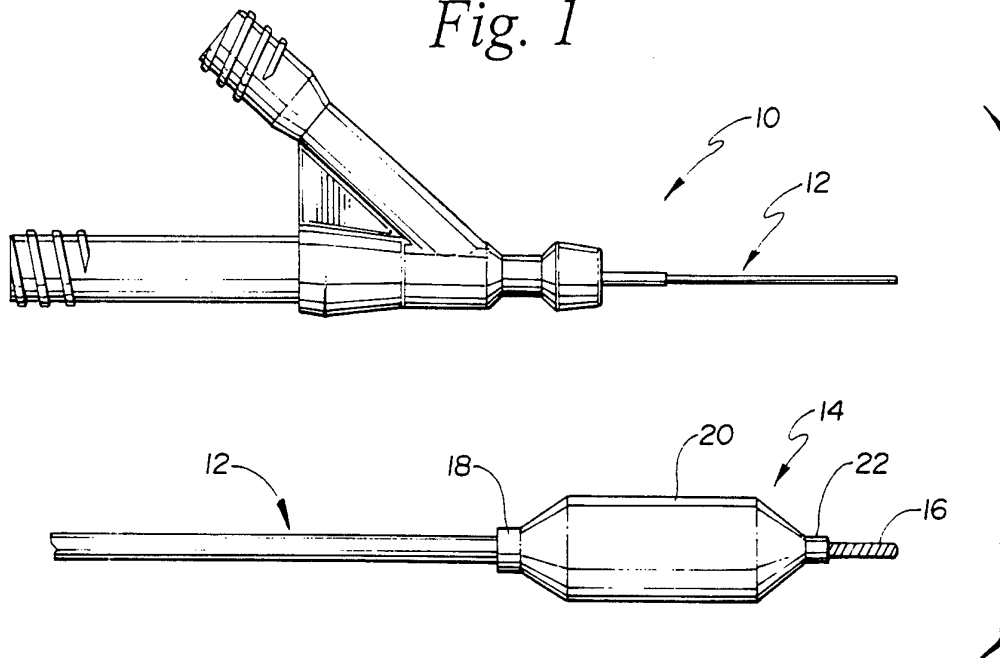

Fig. 2

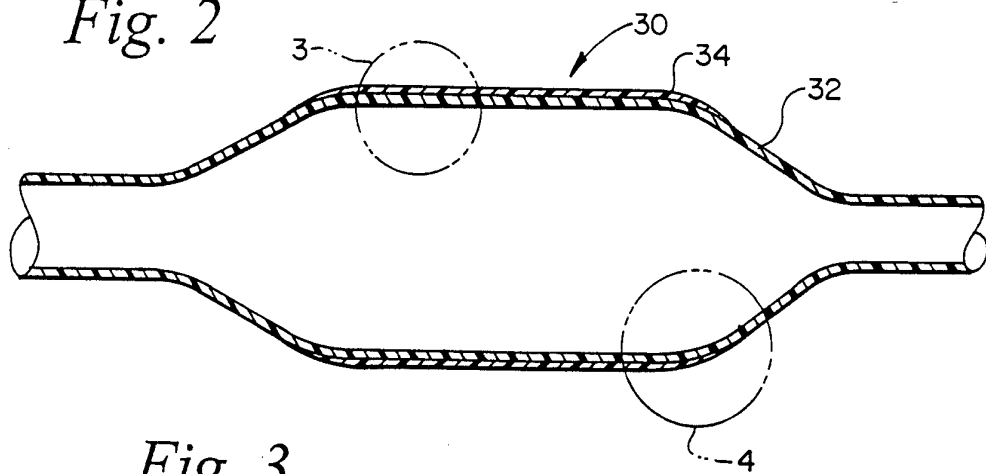

Fig. 3

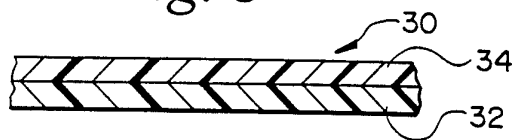

Fig. 4

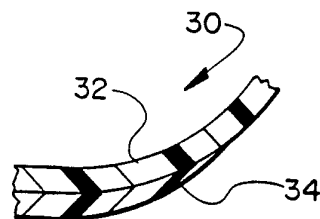

Fig. 5

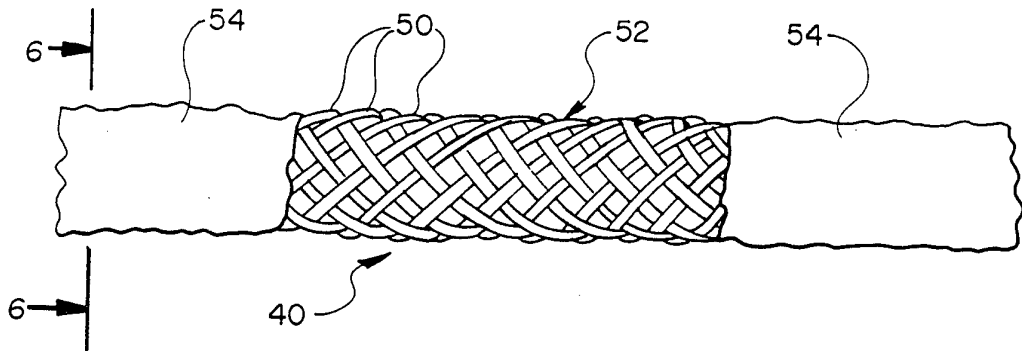

Fig. 6

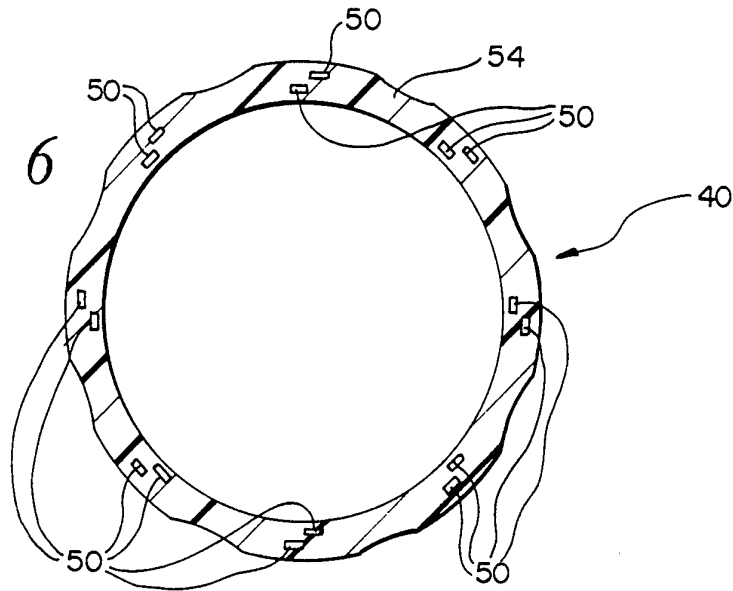

Fig. 7a

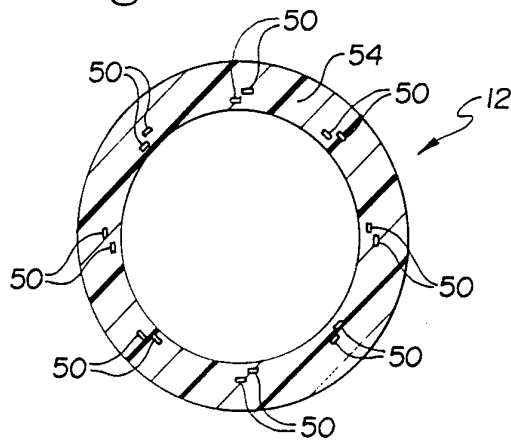

Fig. 7b

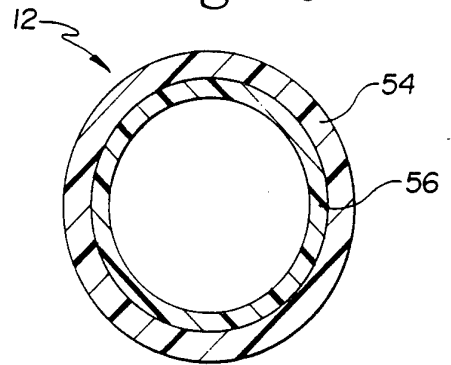

Fig. 8

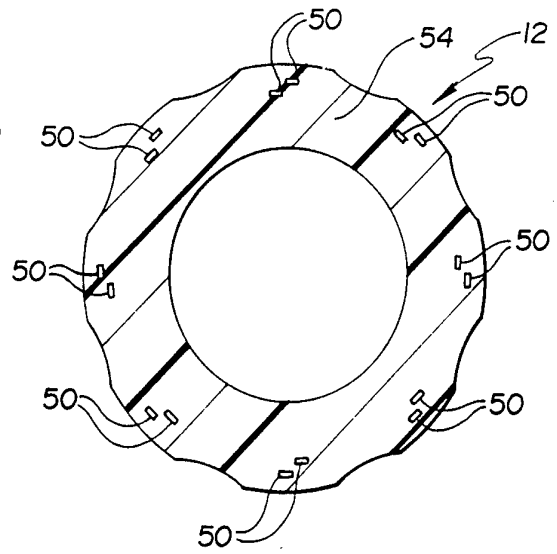

Fig. 9

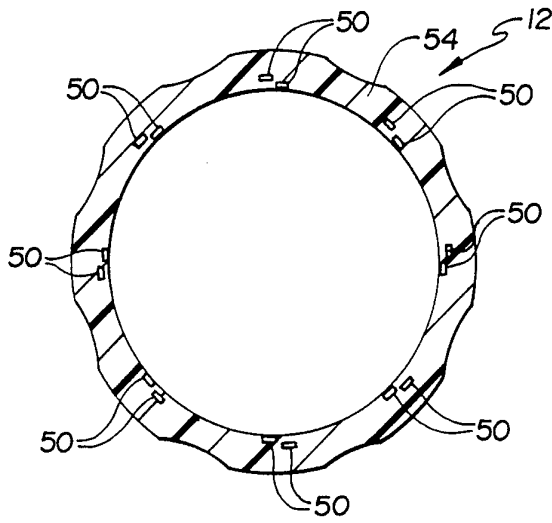

Fig. 10

