



US006904660B2

(12) **United States Patent**
English

(10) **Patent No.:** US 6,904,660 B2
(45) **Date of Patent:** Jun. 14, 2005

(54) **COMPRESSION SLEEVE PULLER WITH DOUBLE THREAD ENGAGEMENT AND METHOD OF MANUFACTURE**

3,104,459 A	*	9/1963	Wendt	29/252
5,054,179 A	*	10/1991	Rini	29/213.1
5,119,556 A	*	6/1992	Hseu	29/264
5,519,929 A	*	5/1996	Bleckman	29/264

(76) **Inventor:** Richard LeRoy English, 6727 E. Swarthmore Dr., Anaheim Hills, CA (US) 92807

* cited by examiner

(*) **Notice:** Subject to any disclaimer, the term of this patent is extended or adjusted under 35 U.S.C. 154(b) by 125 days.

Primary Examiner—David P. Bryant
Assistant Examiner—Stephen Kenny

(57) **ABSTRACT**

(21) **Appl. No.:** 10/640,949

(22) **Filed:** Aug. 15, 2003

(65) **Prior Publication Data**

US 2004/0031139 A1 Feb. 19, 2004

Related U.S. Application Data

(62) Division of application No. 10/119,365, filed on Apr. 9, 2002, now Pat. No. 6,637,089.

(51) **Int. Cl.**⁷ B23P 11/00

(52) **U.S. Cl.** 29/434; 29/450; 29/235; 29/426.5; 29/255; 285/417; 285/420

(58) **Field of Search** 29/434, 450, 235, 29/234, 426.5, 255, 256, 278, 270; 285/417, 420

A puller (10) for removing a compression sleeve from a pipe (38) generally comprised of a cylindrical body (24) containing on one end an internal cavity (28) to receive the pipe (38) and an external double thread (30) to engage a compression nut (34) and on the opposite end a threaded through screw (14) entering the cavity (28). A disk (22) attached at one end of the screw (14) bears on the end of the pipe (38) and a torque handle (12) at the other end is used to supply increasing pressure against the end of the pipe (38). The puller (10) is threadably attached to the compression nut (34) placing the pipe (38) into the internal cavity (28) against the disk (22) while the compression sleeve (36) is contained between the compression nut (34) and the puller (10). Turning the torque handle (12) urges the compression nut (34) and the compression sleeve (36) toward the end of the pipe (38) until the compression nut (34) and compression sleeve (36) are freed from the pipe (38).

(56) **References Cited**

U.S. PATENT DOCUMENTS

2,487,331 A * 11/1949 Greene 29/264

3 Claims, 1 Drawing Sheet

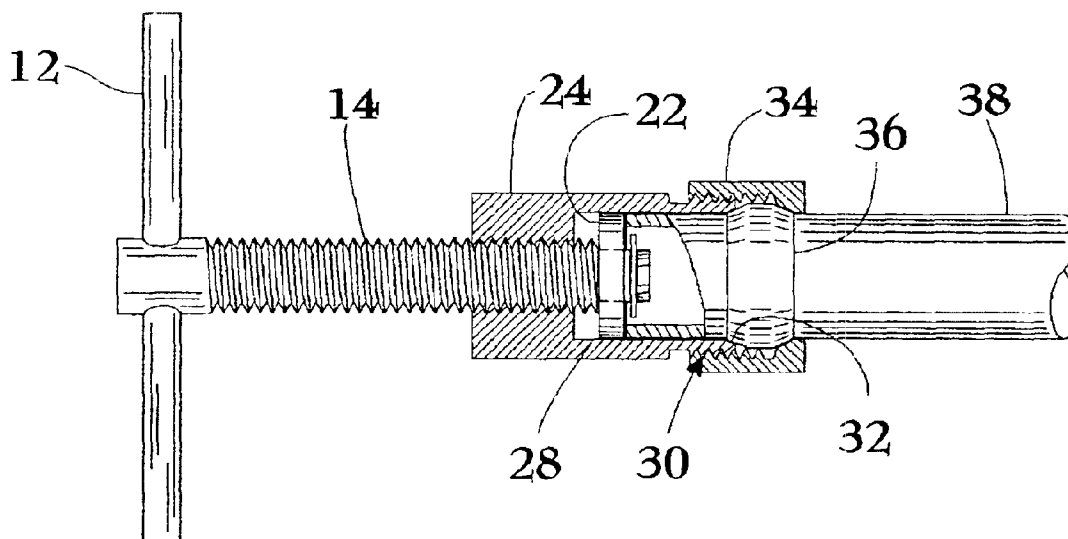

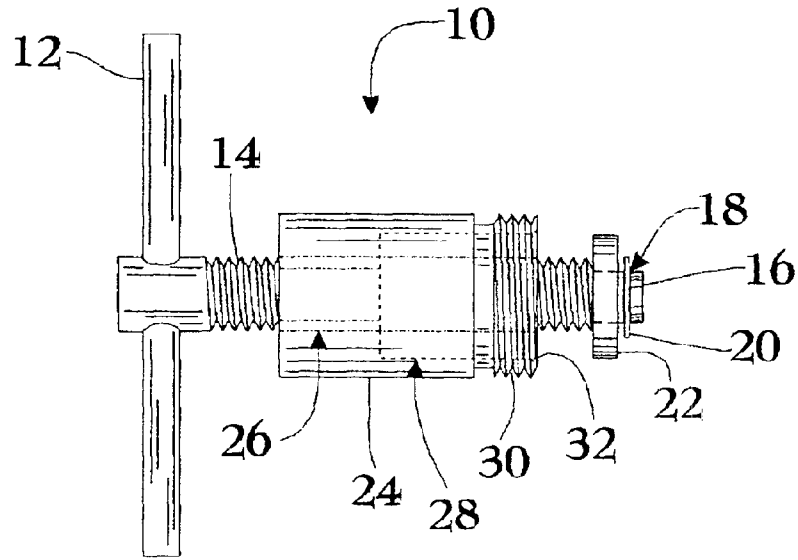

Fig. 1

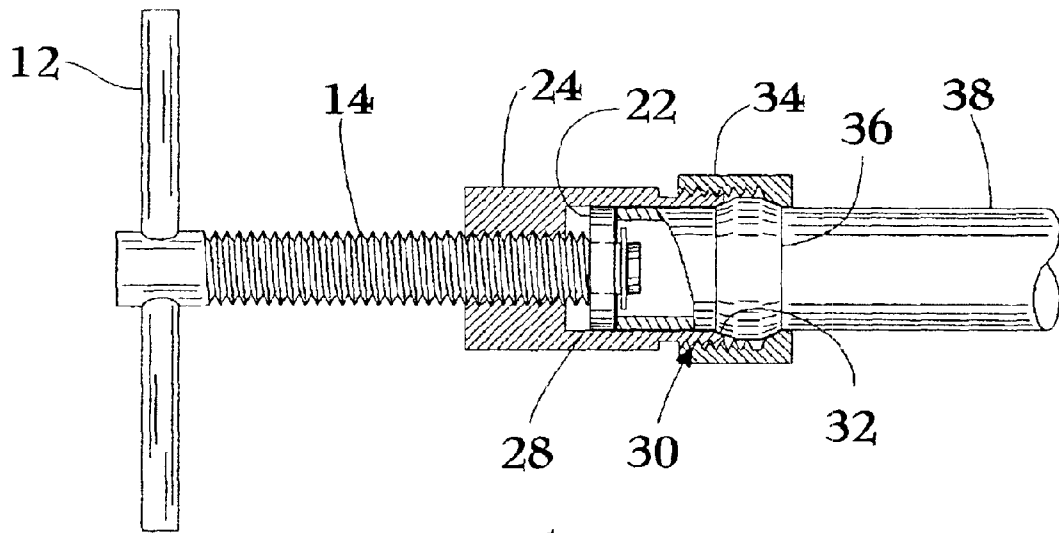

Fig. 2

COMPRESSION SLEEVE PULLER WITH DOUBLE THREAD ENGAGEMENT AND METHOD OF MANUFACTURE

CROSS REFERENCES TO RELATED APPLICATIONS

Division of application Ser. No. 10/119,365 filed Apr. 9, 2002 now U.S. Pat. No. 6,637,089. Incorporated herein by reference is the entire text of said application.

BACKGROUND OF THE INVENTION

1. Field of the Invention

This invention relates to pullers, in particular to compression sleeve pullers having a duality of screw thread engagement and includes method of manufacture.

2. Description of Prior Art

A pipe which contains pressurized fluid may be connected to a valve which is used to dispense the pressurized fluid in a controlled manner. An example is household plumbing lines bringing water into the premises. The individual branches of the plumbing system are routed inside the walls of the house and terminate inside a room such as a bathroom or kitchen. The plumbing lines protrude through the wall far enough to attach a water valve. A common method of attaching and sealing a water valve to a plumbing line is to employ the use of a compression fitting consisting of a compression nut, a compression sleeve and the valve. To install the valve, (1) the compression nut is placed on the pipe; (2) the closely fitting compression sleeve is slipped onto the pipe; and (3) the valve is pushed on and engaged with the compression nut. The nut is then tightened onto the valve to compress the compression sleeve onto the pipe. The compression sleeve creates both a mechanical grip for the valve and a pressure seal for the fluid. Other methods of attaching the valve include: (a) threading the valve into a threaded pipe fitting and sealing the point of attachment with pipe sealant; or (b) soldering the valve to the pipe. When a valve wears out or fails, it must be removed and replaced. This invention applies only to the removal of valves which are attached using the compression sleeve method of attaching and sealing.

When replacing a valve or other device attached to a pressurized pipe by means of a compression sleeve fitting, it is important to remove the old compression sleeve and replace it with a new compression sleeve to ensure proper sealing. Generally, plumbing pipe comprises thin wall copper tubing. This tubing is easily damaged when old compression sleeves are reused because the old sleeve generally must be over-tightened to obtain a seal.

The removal of the old compression sleeve requires specially designed tooling to pull the old sleeve off the copper pipe without damage to the pipe. If the pipe is dented, scratched or deformed, it is generally impossible to reseat with a compression sleeve. This results in the need to replace the damaged pipe or otherwise causes extra work and expense.

Compression nuts used for this application come in two standard thread designs: coarse thread and fine thread. Although both thread designs possess the same inner diameter, two puller tools are required to couple with the differing thread designs. In lieu of two tools, the prior art discloses a single tool which incorporates a removable adapter to change from the coarse thread to the fine thread or vice versa. This type of puller is shown in U.S. Pat. No. 5,519,929 issued to Bleckman. Bleckman discloses a remov-

able threaded adapter which threads to the end of the body of the tool to provide coupling to the alternate thread design. For example, if the tool is manufactured with the fine thread design at the coupling end, then the adapter is manufactured with a fine inner thread, a stepped down inner portion to match the inner diameter of the tool body, a hexagonal or knurled outer diameter for aid in threading it to the tool body, and a coarse outer thread to mate with the compression nut to be removed. This adapter represents 50% of the utility of the tool and approximately 30% of the total cost of the tool.

The required adapter is easily lost or misplaced. Moreover, the adapter is difficult to find in a plumber's toolbox because of its diminutive size. Also, the use of the adapter increases the length of the tool thereby decreasing its usefulness. Bleckman points out that the longer the tool, the more difficult it is to use in the normal plumbing environment of tight quarters and adjacent obstacles such as pipes, sinks and walls. The disadvantages of the additional removable adapter are significant enough to make the tool as a whole less desirable to both the professional plumber and the handyman.

The Bleckman design also discloses an unnecessarily complex and costly bearing device/alignment plug consisting of a larger diameter cylindrical bearing device stepped down to a smaller diameter, tapered, alignment plug used to center the bearing device to the edge of the pipe. Alignment is necessary to prevent the larger diameter bearing device from catching on the compression sleeve as it passes through. The complexity of the bearing device/alignment plug adds unnecessary cost and size to the tool. It has been discovered that if the tapered alignment plug is eliminated and the cylindrical bearing device is replaced by a relatively thin, loose fitting, rotatable disk, the tool operates perfectly well without the additional alignment plug. It was found that when the disk encounters the compression ring, it self-centers and passes through with no difficulty. The simple disk comprises only about 2% of the cost of the tool whereas the complex bearing device/alignment plug disclosed by Bleckman comprises about 15% of the cost of that tool. Therefore, by eliminating the adapter and replacing the bearing device/alignment plug with a simple disk, the cost of the tool is reduced by about 43%.

The Bleckman design suffers from the following disadvantages:

- (a) the separate adapter which is necessary for the tool to be used for both fine and coarse compression nuts is expensive;
- (b) the separate adapter adds undesirable length to the tool;
- (c) the separate adapter is easily lost or misplaced;
- (d) the bearing device/centering plug is overly complex and expensive.

Therefore, there is a need for a less complex and costly tool which couples to both fine and coarse threaded compression nuts without the use of an undesirable adapter and operates smoothly without the need for a complicated bearing device/centering plug.

3. Summary of the Invention

The present invention is a dual thread design compression sleeve puller which fits both coarse and fine threads without the use of an additional adapter. The two threads, coarse and fine, are both cut in the threaded end of the tool so that the tool automatically fits either thread on the compression nut. This overcomes the disadvantages of the thread adapter necessary for prior art and makes the tool more productive

and less expensive. It also eliminates the possibility of loss of the adapter. The present invention also eliminates the bearing device/centering plug and replaces it with a simple disk which functions for both purposes.

4. Objects and Advantages

It is therefore an object of the present invention to provide a new and useful compression sleeve puller with a double thread engagement. Further objects and advantages of the present invention are as follows:

- (a) to provide a puller which threadably couples to compression nuts of either fine or coarse thread design without the use of an adapter;
- (b) to provide a tool which does not require the use of an alignment plug for centering on the pipe;
- (c) to provide a puller of simple design which is easy to use in tight quarters;
- (d) to provide a puller which is durable enough for the professional and inexpensive enough for the handyman or homeowner;
- (e) to provide a puller which is easy to attach to the compression nut without the use of tools and supports itself when so attached;
- (f) to provide a puller which can be operated simply, quickly and in most cases with one hand;
- (g) to provide a puller which can be attached and operated by a person with average skill and strength,
- (h) to provide a puller which reduces the time and effort for the removal of compression sleeves and increases productivity; and
- (i) to provide a method of manufacture which will overcome the limitations and disadvantages of threaded pullers heretofore provided.

BRIEF DESCRIPTION OF THE DRAWINGS

FIG. 1 depicts the preferred embodiment of the puller.

FIG. 2 shows the puller in partial section as typically used engaged with a compression nut, compression sleeve and pipe.

REFERENCE NUMBERS IN DRAWINGS

- 10 compression sleeve puller
- 12 torque handle
- 14 screw
- 16 shaft
- 18 groove
- 20 retaining clip
- 22 disk
- 24 body
- 26 internal thread
- 28 internal cavity
- 30 external double thread
- 32 chamfer
- 34 compression nut
- 36 compression sleeve
- 38 pipe

DETAILED DESCRIPTION OF THE PREFERRED EMBODIMENT

The preferred embodiment of the compression sleeve puller is illustrated in FIGS. 1 and 2. FIG. 1 shows puller 10 composed of a generally cylindrical body 24 with internal thread 26 at one end for threaded engagement with screw 14 and external thread 30 at the opposite end for threaded engagement with compression nut 34 (FIG. 2). Body 24 may

be hexagonal or knurled for a better grip. Body 24 has an internal cavity 28 to receive circular disk 22 and an inner chamfer 32 on the open end of cavity 28 to provide a close fit with compression sleeve 36 (FIG. 2). Screw 14 has a torque handle 12 fitted on one end and a smaller diameter shaft 16 on the opposite end onto which disk 22 is retained by retaining clip 20 in groove 18. Disk 22 contains a center hole to rotatably mount onto said shaft 16 and has an outside diameter to closely fit into cavity 28 and yet slide easily therein.

FIG. 2 shows puller 10 in partial sectional view attached to pipe 38 by nut 34 which contains a sleeve 36 compressed onto pipe 38 and is to be removed therefrom. Nut 34 is threaded on to thread 30 thereby holding pipe 38 tightly against disk 22. The rotatable mounting of disk 22 allows for reduced effort when handle 12 is turned forcing disk 22 against the end of pipe 38. Disk 22 does not rotate against the end of pipe 38 where the contact diameter is relatively large but instead rotates against screw 14 where the contact diameter is small thus reducing the effort needed to turn handle 12. Cavity 28 is slightly more than $\frac{3}{8}$ inch deep which is enough to contain the thickness of disk 22 and to receive pipe 38 engaged fully up to the position of sleeve 36. The inner diameter of cavity 28 is just over $\frac{3}{8}$ inch and is closely dimensioned to the outside diameter of pipe 38 for a slidable fit. Screw 14 is approximately two inches in length and is long enough to contain handle 12 and shaft 16 and capable of advancing far enough to push disk 22 at least $\frac{3}{8}$ inch beyond the end of cavity 28 so that it passes completely through sleeve 36. As screw 14 is turned using handle 12, disk 22 advances against the end of pipe 38 and urges it out of cavity 28. Screw 14 is further turned urging pipe 38 through sleeve 36 freeing sleeve 36 from pipe 38. The various components of puller 10 are made of stainless steel to resist corrosion and for easy cleaning and long life.

To illustrate one important aspect of this invention, attention is given to the particular case of copper plumbing commonly used for distributing and dispensing water throughout a standard residence or business. Copper plumbing is comprised of copper tubing with an inner diameter of $\frac{1}{2}$ inch and an outer diameter of $\frac{5}{8}$ inch. Water control valves and compression nuts used with compression fittings on this size pipe come in two thread designs: fine pitch and coarse pitch. The fine pitch thread is a $1\frac{3}{16}$ -18 NF thread hereinafter referred to as fine thread, and the coarse pitch thread is a straight pipe thread, $\frac{1}{2}$ -14 NPS hereinafter referred to as coarse thread. These two threads are of substantially identical diameters. A threadably engaging puller may be manufactured with either a coarse thread or a fine thread in which case two tools, or at least a tool with a relatively expensive adapter, are required to fit all possible jobs of this pipe size. It is an object of the invention to have a single tool which fits both thread designs and is simple and inexpensive. In an effort to do this, two discoveries were made. First, it was discovered that a fine thread may be cut over a coarse thread (or alternatively a coarse thread over a fine thread) resulting in a "single entry, double pitch thread" which will fit both fine thread and coarse thread compression nuts. The discovery of the double thread enhances the utility of puller 10 and eliminates the need for a separate adapter. It was also found that a simple disk 22 may be used in place of the more complicated and costly bearing device/alignment plug used in the prior art.

In the preferred embodiment, thread 30 is a single entry, double pitch thread which engages with compression nut 34 whether it has a coarse thread or a fine thread. This double thread 30 may be manufactured by first cutting a fine thread

5

(¹³/₁₆-18NF) on body **24** and carefully noting the entry point of the thread. Then, using the same entry point, a coarse thread (¹/₂-14NPS) is cut on body **24** directly over said fine thread resulting in double thread **30**. The second thread will clear a path for itself through the pattern of the first cut thread. Since both threads start at the same entry point, a fine thread compression nut or alternatively a coarse thread compression nut each start threading on at the same entry point and automatically find their own path on double thread **30**. Since the fine and coarse threads have different pitches, they will intersect every few turns and result in areas where the major diameter of one thread is cut away to provide for the minor diameter of the other. The appearance of the resulting double thread is a bifurcated look but operates perfectly well for both compression nuts, fine or coarse. Some material is removed from the thread in the process of double threading so the ultimate strength of each of the two threads is reduced. However, each thread is of sufficient strength for removing even the tightest compression sleeves. In addition, the first two or three turns of said double thread are substantially whole, so its strength for use on this tool is more than adequate. Because of the geometry of nut **34** and sleeve **36**, puller **10** will engage nut **34** by fewer than three turns before bottoming out against sleeve **36**. The strength of the engaged threads is only slightly reduced from that of a standard coarse thread or fine thread. In the preferred embodiment, the thread **30** of puller **10** is steel while the thread of nut **34** is generally brass so that even the reduced strength of thread **30** is substantially greater than the strength of the thread of nut **34**. Testing shows that even corroded and overly compressed sleeves **36** are easily removed with puller **10**.

Although an illustration herein cites the use and design of puller **10** specifically for ¹/₂ inch copper pipe, it is in no way intended to limit the use of said puller to that particular use. It is to be noted here that puller **10** may be scaled to larger or smaller pipe applications without changing the spirit or intent of the invention.

OPERATION

Puller **10** is used after a water valve is removed from pipe **38** and the compression nut **34** remaining on the pipe is retained by a compression sleeve **36**. Puller **10** is operated as follows: (a) prepare puller **10** by turning handle **12** counter clockwise until disk **22** is drawn as deeply as possible into cavity **28** (b) hand tighten external double thread **30** to nut **34** on pipe **38** (c) turn handle **12** clockwise until disk **22** pushes pipe **38** completely through sleeve **36** freeing nut **34** and sleeve **36** from pipe **38** (d) discard compression nut **34** and compression sleeve **36**.

CONCLUSIONS, RAMIFICATIONS AND SCOPE

From the foregoing description it is seen that the invention provides an extremely simple, efficient, low cost and reliable manner for removing compression sleeves from pipes.

While in the foregoing there have been set forth the preferred embodiment of the invention, it will be appreciated that the details herein given may be varied by those skilled in the art without departing from the true spirit and scope of the appended claims.

Thus the scope of the invention should be determined by the appended claims and their legal equivalents, rather than by the examples given.

I claim:

1. The method of manufacture of threadably engaged pullers used for removing a compression sleeve from a pipe

6

by engaging the thread on the compression nut and pulling said compression nut and said compression sleeve off said pipe comprising:

- 5 providing a cylindrical body possessing a first end and a second end;
- providing said first end of said cylindrical body with a recessed cavity having an inner diameter greater than the outer diameter of said pipe and a depth sufficient to accept said pipe up to said compression sleeve;
- 10 providing said first end of said cylindrical body with an external thread to match the thread on said compression nut, pitch of said thread may be either fine or coarse;
- providing said second end of said cylindrical body with a centered hole;
- 15 providing said centered hole with an inner thread to accept an advancing screw;
- providing a screw possessing a first end and a second end passing through said hole in said second end of said cylindrical body such that said first end of said screw advances into said cavity of said cylindrical body and longitudinally through said cylindrical body;
- 20 providing a smaller diameter shaft attached at said first end of said screw with a groove therein;
- 25 providing a disk slidably and rotatably attached to said shaft;
- providing a clip attached to said groove on said shaft to retain said disk; and
- 30 providing a torque handle at said second end of said screw to provide turning force on said screw.

2. The method of manufacture of threadably engaged pullers containing a double thread used for removing a compression sleeve from a pipe by engaging the thread on the compression nut and pulling said compression nut and said compression sleeve off said pipe comprising:

- 35 providing a cylindrical body possessing a first end and a second end;
- providing said first end of said cylindrical body with a recessed cavity having an inner diameter greater than the outer diameter of said pipe and a depth sufficient to accept said pipe up to said compression sleeve;
- 40 providing said first end of said cylindrical body with an external double thread to engage said thread on said compression nut with indifference to the pitch of said compression nut thread, fine or coarse, said external double thread being manufactured by cutting said external fine and said external coarse threads onto said first end of said cylindrical body over one another using a single entry for said threads thereby creating a "single entry double pitch thread;"
- 45 providing a centered hole at said second end of said cylindrical body;
- providing said centered hole with an inner thread to accept an advancing screw;
- 50 providing a screw possessing a first end and a second end passing through said hole in said second end of said cylindrical body such that said first end of said screw advances into said cavity of said cylindrical body and longitudinally through said cylindrical body;
- providing a smaller diameter shaft attached at said first end of said screw with a groove therein;
- 55 providing a disk slidably and rotatably attached to said shaft;
- providing a clip attached to said groove on said shaft to retain said disk; and

7

providing a torque handle at said second end of said screw to provide turning force on said screw.

3. The method of manufacture of the “single entry double pitch thread” of claim 2 comprising:

providing suitable material stock to receive said thread, 5
said material stock may be capable of receiving either an internal thread as in the case of a nut or an external thread as in the case of a bolt;

providing means for cutting a relatively fine pitch thread 10
onto said stock;

providing means for cutting a relatively coarse pitch thread onto said stock, said means for cutting said fine thread or said coarse thread is suited for cutting either

8

said external or said internal threads as required to match said material stock provided;

cutting said fine thread onto said stock thereby creating an entry for said fine thread on said stock;

cutting said coarse thread onto said stock using said entry 5
created by the previously cut said fine thread and cutting said coarse thread over said fine thread, sequence of cutting said threads may be fine-then-coarse or coarse-then-fine, in either case both said fine and said coarse threads are cut through a single entry over one another creating said “single entry double pitch thread.”

* * * * *