



US00D735913S

(12) **United States Design Patent**
Mays et al.

(10) **Patent No.:** **US D735,913 S**

(45) **Date of Patent:** **** Aug. 4, 2015**

(54) **VEHICLE PARK LAMP**

- (71) Applicant: **Ford Motor Company**, Dearborn, MI (US)
- (72) Inventors: **J C. Mays**, Bloomfield Hills, MI (US);
Moray S. Callum, Ann Arbor, MI (US);
Joel Piaskowski, Brighton (AU);
Darrell Behmer, Novi, MI (US); **Kemal Curic**, West Bloomfield, MI (US)
- (73) Assignee: **Ford Motor Company**, Dearborn, MI (US)
- (**) Term: **14 Years**
- (21) Appl. No.: **29/476,659**
- (22) Filed: **Dec. 16, 2013**

Related U.S. Application Data

- (63) Continuation of application No. 29/469,983, filed on Oct. 16, 2013, now Pat. No. Des. 710,762.
- (51) **LOC (10) Cl.** **26-06**
- (52) **U.S. Cl.**
USPC **D26/28**
- (58) **Field of Classification Search**
USPC D26/28-36; 362/459-468, 475-478,
362/485-487

See application file for complete search history.

(56) **References Cited**

U.S. PATENT DOCUMENTS

D541,445 S *	4/2007	Lin	D26/28
D549,363 S *	8/2007	Pfeiffer	D26/28
D552,769 S *	10/2007	Leclercq	D26/28
D553,269 S *	10/2007	Pfeiffer et al.	D26/28
D570,015 S *	5/2008	Hsu	D26/28
D574,524 S *	8/2008	Tomatsu	D26/28
D605,793 S *	12/2009	Weil	D26/28

* cited by examiner

Primary Examiner — Marcus Jackson

(74) *Attorney, Agent, or Firm* — Damian Porcari

(57) **CLAIM**

The ornamental design for a vehicle park lamp, as shown and described.

DESCRIPTION

FIG. 1 is a left side elevational view of a left vehicle park lamp (the right vehicle park lamp being a mirror image and is not shown);
 FIG. 2 is a right side elevational view thereof;
 FIG. 3 is a front elevational view thereof;
 FIG. 4 is a top plan view thereof;
 FIG. 5 is a bottom plan view thereof;
 FIG. 6 is a top perspective view thereof;
 FIG. 7 is a bottom perspective view thereof;
 FIG. 8 is a front elevational view of a left vehicle park lamp reflector (the right vehicle park lamp reflector being a mirror image and is not shown) for a headlamp without leveling; and,
 FIG. 9 is a front elevational view of a left vehicle park lamp reflector (the right vehicle park lamp reflector being a mirror image and is not shown) for headlamp with leveling.

1 Claim, 9 Drawing Sheets

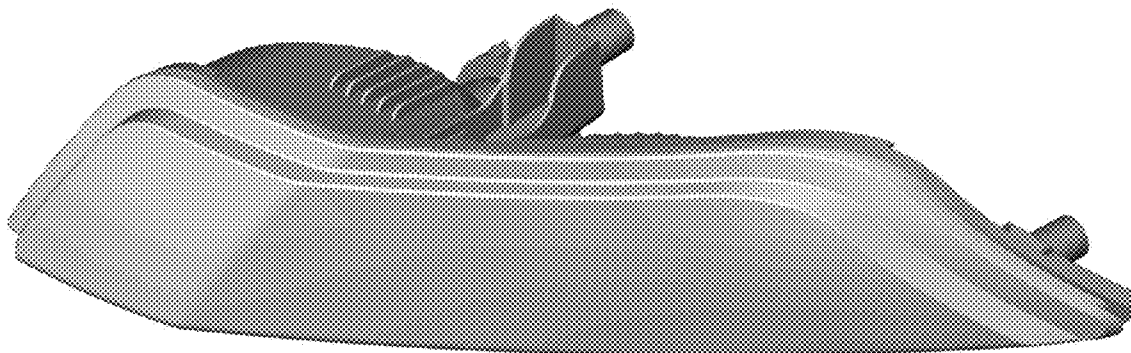



Figure 1

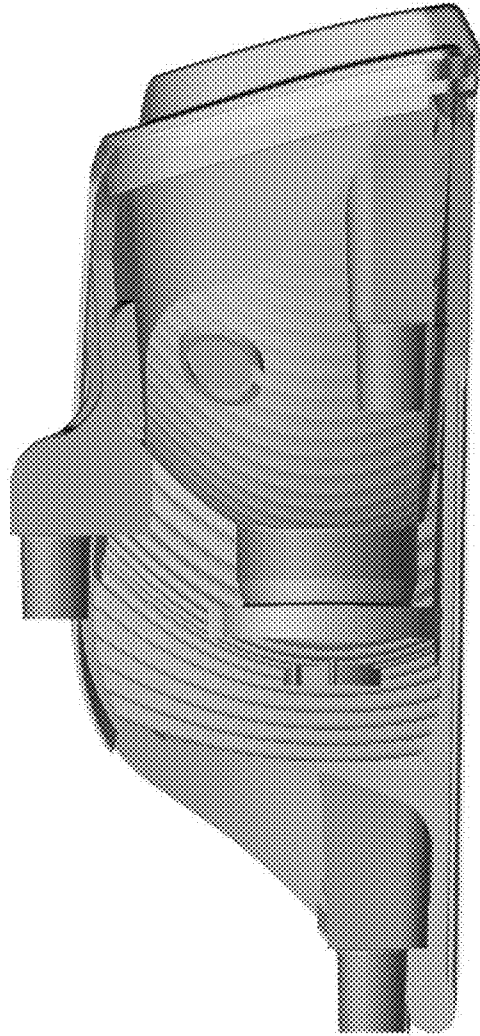

Figure 2

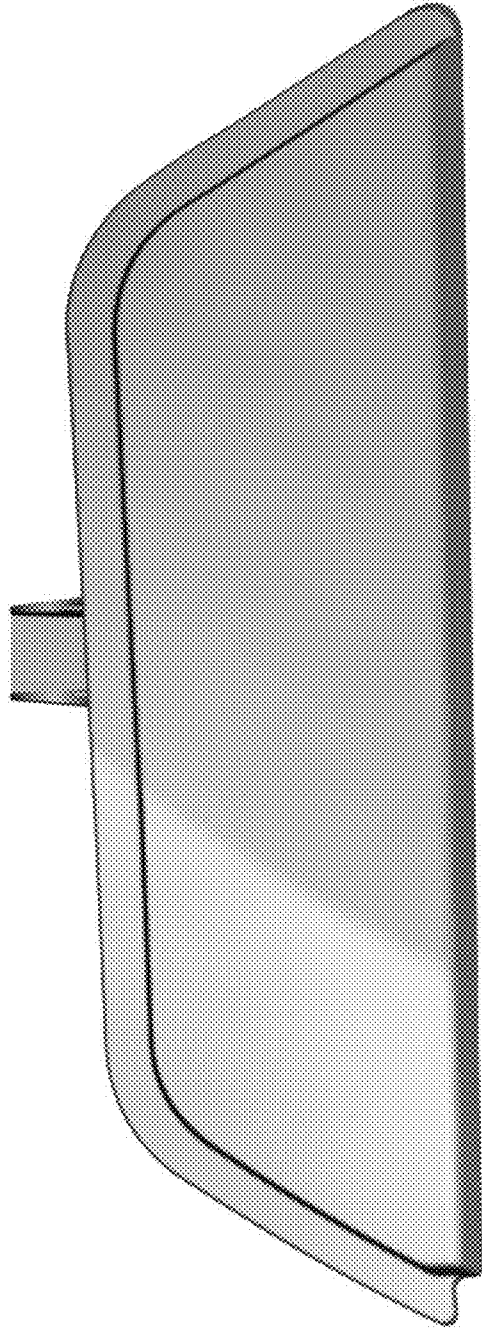

Figure 3

Figure 4

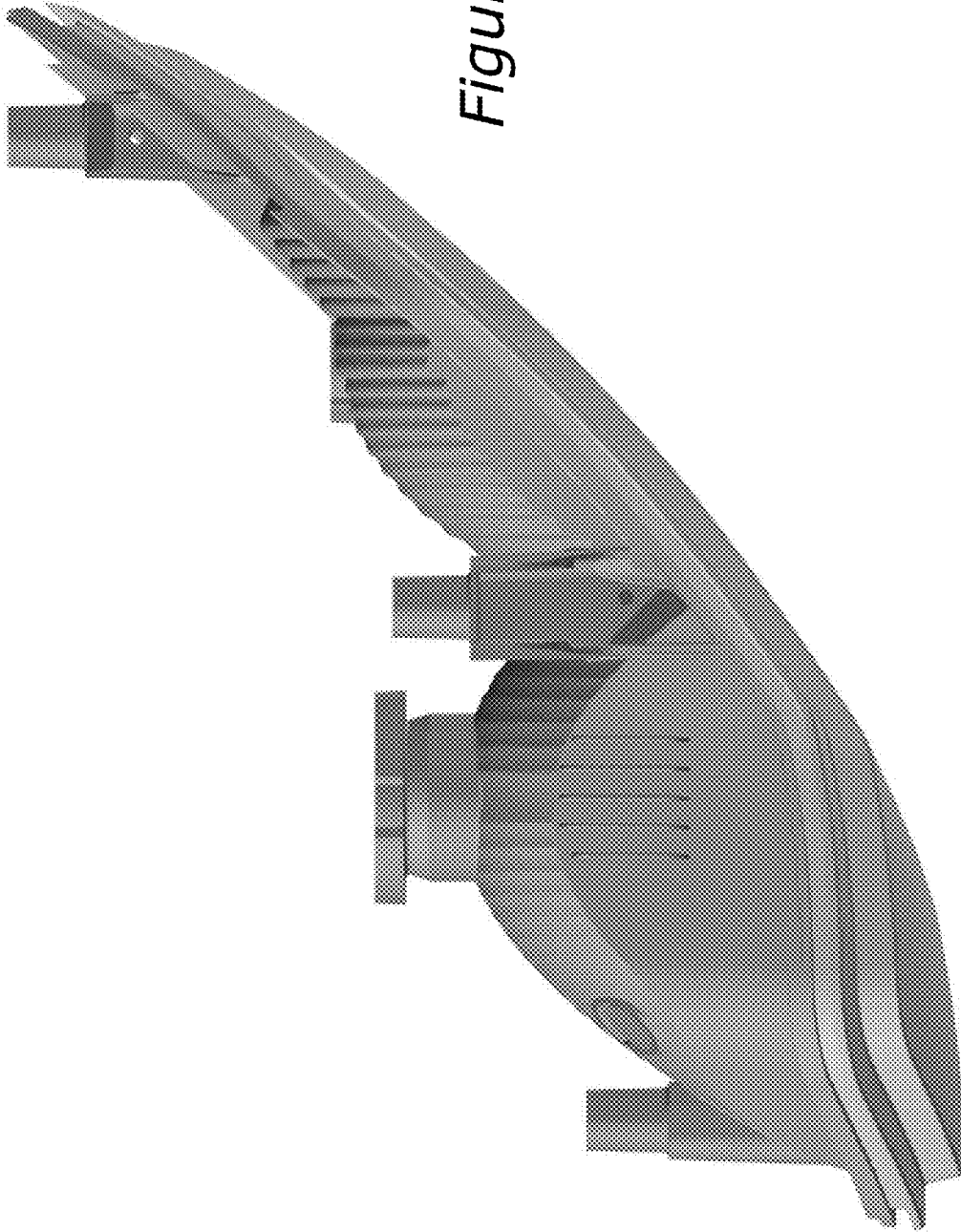
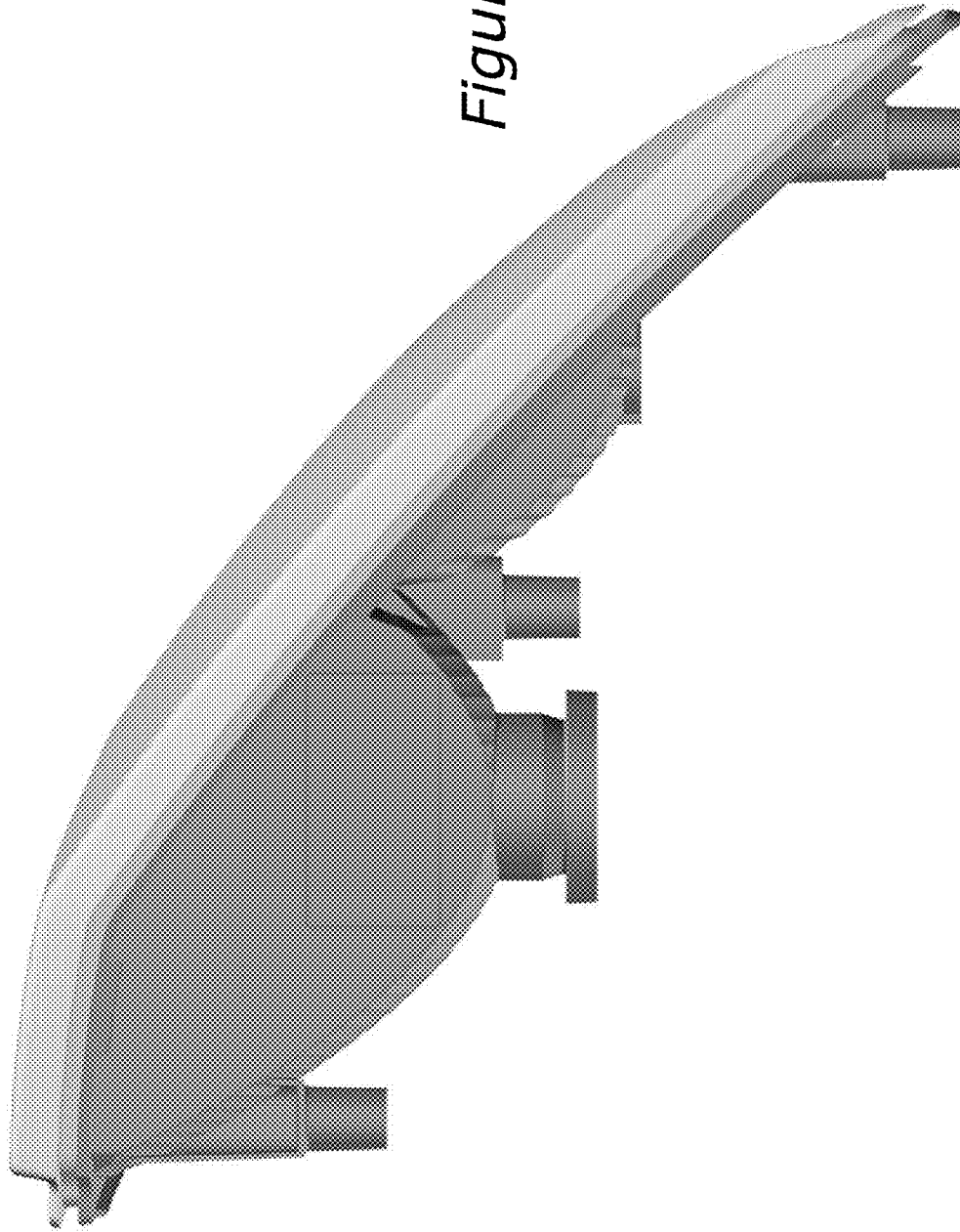

Figure 5



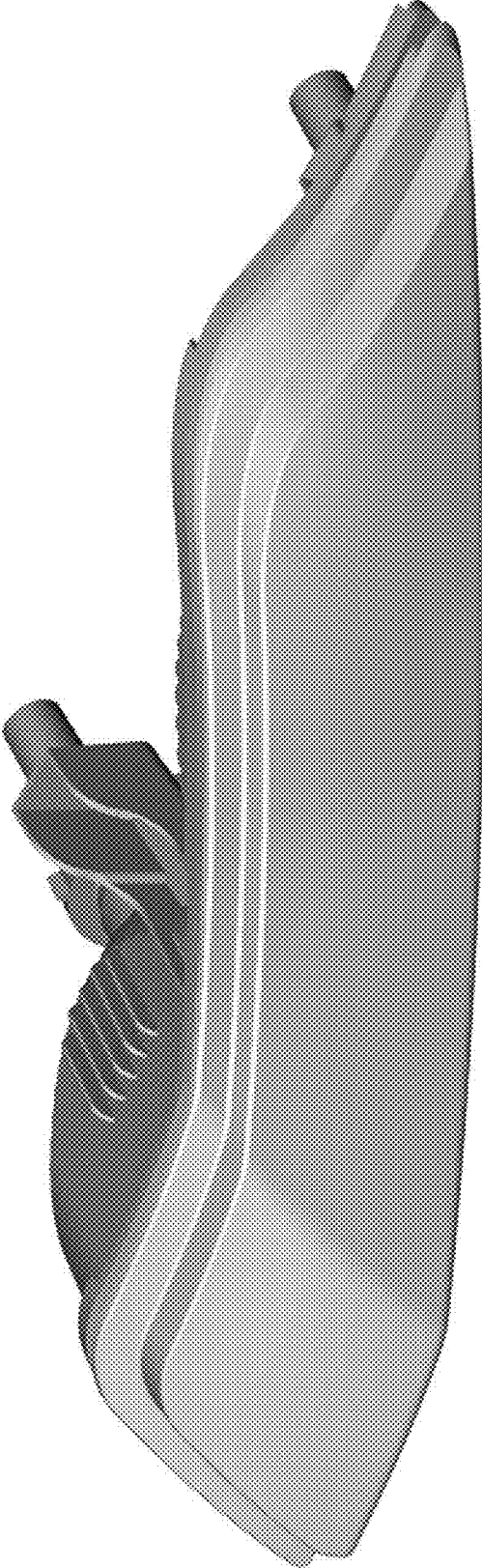

Figure 6



Figure 7

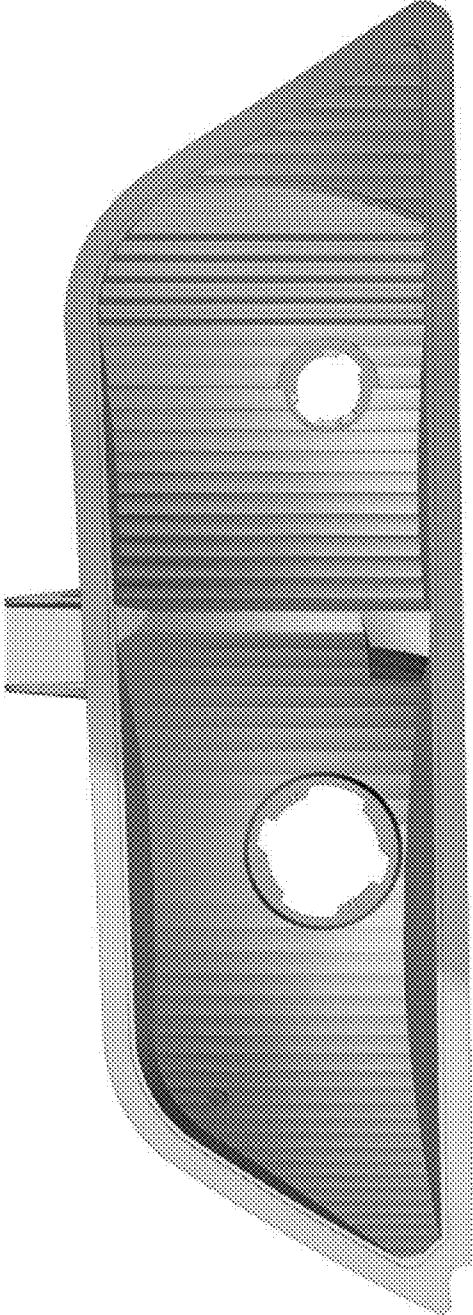

Figure 8

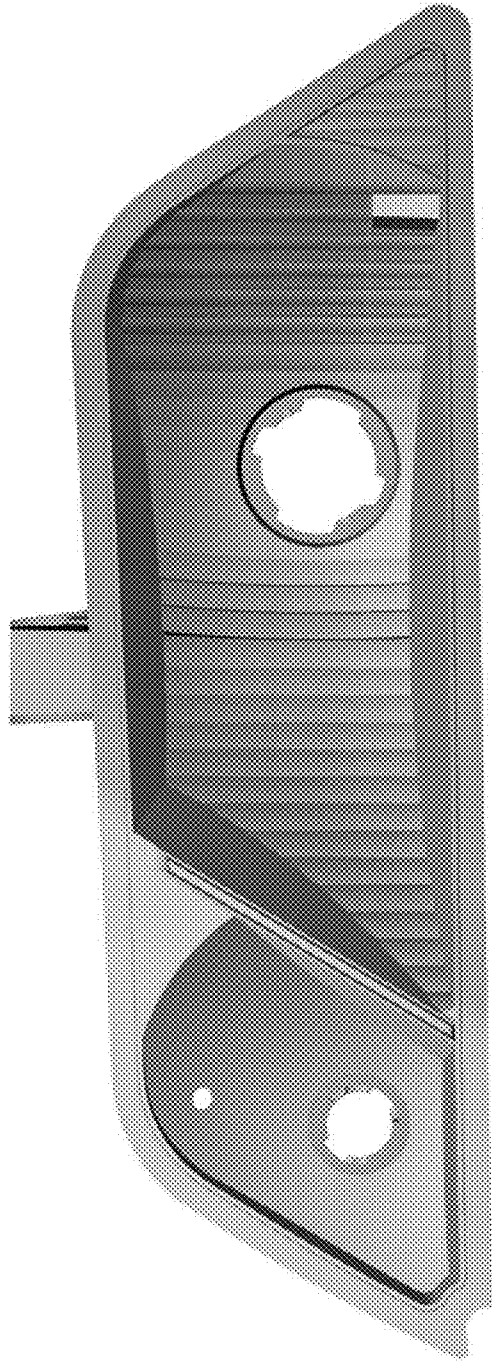

Figure 9