

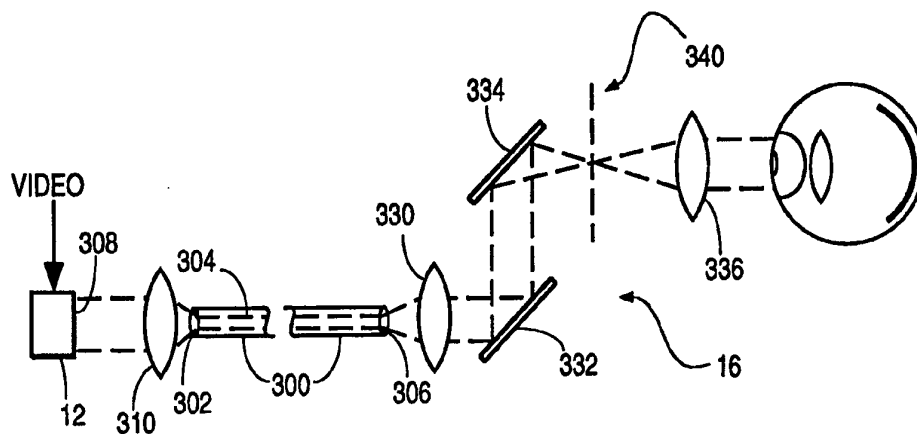

INTERNATIONAL APPLICATION PUBLISHED UNDER THE PATENT COOPERATION TREATY (PCT)

<p>(51) International Patent Classification ⁶ : G09G 3/02</p>	<p>A1</p>	<p>(11) International Publication Number: WO 96/36036</p> <p>(43) International Publication Date: 14 November 1996 (14.11.96)</p>
<p>(21) International Application Number: PCT/US96/05431</p> <p>(22) International Filing Date: 19 April 1996 (19.04.96)</p> <p>(30) Priority Data: 08/437,818 9 May 1995 (09.05.95) US</p> <p>(71) Applicant: UNIVERSITY OF WASHINGTON [US/US]; Suite 200, 1107 N.E. 45th Street, Seattle, WA 98105 (US).</p> <p>(72) Inventors: FURNESS, Thomas, A., III; 7359 58th Avenue, N.E., Seattle, WA 98115 (US). MELVILLE, Charles, D.; 3631 241st Avenue, S.E., Issaquah, WA 98027 (US). TIDWELL, Michael, R.; 1944 11th Avenue West, Seattle, WA 98119 (US).</p> <p>(74) Agents: KUELPER, Jean, Dudek et al.; McAndrews, Held & Malloy, Ltd., Suite 3400, 500 West Madison, Chicago, IL 60661 (US).</p>		<p>(81) Designated States: AL, AM, AT, AU, AZ, BB, BG, BR, BY, CA, CH, CN, CZ, DE, DK, EE, ES, FI, GB, GE, HU, IS, JP, KE, KG, KP, KR, KZ, LK, LR, LS, LT, LU, LV, MD, MG, MN, MW, MX, NO, NZ, PL, PT, RO, RU, SD, SE, SG, SI, SK, TJ, TM, TT, UA, UG, UZ, VN, ARIPO patent (KE, LS, MW, SD, SZ, UG), Eurasian patent (AM, AZ, BY, KG, KZ, MD, RU, TJ, TM), European patent (AT, BE, CH, DE, DK, ES, FI, FR, GB, GR, IE, IT, LU, MC, NL, PT, SE), OAPI patent (BF, BJ, CF, CG, CI, CM, GA, GN, ML, MR, NE, SN, TD, TG).</p> <p>Published <i>With international search report.</i></p>

(54) Title: VIRTUAL RETINAL DISPLAY WITH FIBER OPTIC POINT SOURCE



(57) Abstract

A virtual retinal display utilizes photon generation and manipulation to create a panoramic, high resolution, color virtual image that is projected directly onto the retina of the eye. The virtual retinal display includes a source of photons, the photons being modulated with video information and scanned by a scanning system in a raster type of pattern directly onto the retina of the user's eye. A single, monofilament optical fiber (300) of very small diameter couples light from the photon generator (308, 314) to the scanning system (16) so as to provide to the scanning system a point source of light at the fiber's exit aperture (306). The photon generator may utilize coherent or non-coherent light. Further, the photon generator may utilize color light emitters so as to scan a colored virtual image directly onto the retina of the user's eye.

FOR THE PURPOSES OF INFORMATION ONLY

Codes used to identify States party to the PCT on the front pages of pamphlets publishing international applications under the PCT.

AM	Armenia	GB	United Kingdom	MW	Malawi
AT	Austria	GE	Georgia	MX	Mexico
AU	Australia	GN	Guinea	NE	Niger
BB	Barbados	GR	Greece	NL	Netherlands
BE	Belgium	HU	Hungary	NO	Norway
BF	Burkina Faso	IE	Ireland	NZ	New Zealand
BG	Bulgaria	IT	Italy	PL	Poland
BJ	Benin	JP	Japan	PT	Portugal
BR	Brazil	KE	Kenya	RO	Romania
BY	Belarus	KG	Kyrgystan	RU	Russian Federation
CA	Canada	KP	Democratic People's Republic of Korea	SD	Sudan
CF	Central African Republic	KR	Republic of Korea	SE	Sweden
CG	Congo	KZ	Kazakhstan	SG	Singapore
CH	Switzerland	LI	Liechtenstein	SI	Slovenia
CI	Côte d'Ivoire	LK	Sri Lanka	SK	Slovakia
CM	Cameroon	LR	Liberia	SN	Senegal
CN	China	LT	Lithuania	SZ	Swaziland
CS	Czechoslovakia	LU	Luxembourg	TD	Chad
CZ	Czech Republic	LV	Latvia	TG	Togo
DE	Germany	MC	Monaco	TJ	Tajikistan
DK	Denmark	MD	Republic of Moldova	TT	Trinidad and Tobago
EE	Estonia	MG	Madagascar	UA	Ukraine
ES	Spain	ML	Mali	UG	Uganda
FI	Finland	MN	Mongolia	US	United States of America
FR	France	MR	Mauritania	UZ	Uzbekistan
GA	Gabon			VN	Viet Nam

- 1 -

**VIRTUAL RETINAL DISPLAY WITH
FIBER OPTIC POINT SOURCE**

SPECIFICATION

FIELD OF INVENTION

The present invention is directed to a virtual image display system and more particularly to a virtual retinal display utilizing an optical fiber to couple light from a light source to a scanning system in order to provide a point source of light at the input of the scanning system.

BACKGROUND OF THE INVENTION

With known virtual image displays, a user does not view directly a physical display screen such as with real image displays. Typically, the virtual display creates only a small physical image using a liquid crystal array, light emitting diodes or a miniature cathode ray tube, CRT, the image being projected by optical lenses and mirrors so that the image appears to be a large picture suspended in the world.

A miniature cathode ray tube can produce a medium resolution monochrome picture. However, these devices are heavy and bulky. For example, a typical weight of a miniature CRT with cables is greater than four ounces, the CRT having a one

- 2 -

inch diameter and a four inch length. Further, these devices have high voltage acceleration potential, typically 7-13 kilovolts which is undesirably high for a display that is mounted on a user's head. Creating color using a single miniature CRT is difficult and usually causes significant compromises in image resolution and luminance. Although the CRT image may be relayed via a coherent fiber-optics bundle to allow the CRT to be located away from head mounted optics, the hardware to accomplish this is also heavy and causes significant light loss. Field sequential color using a multiplexed color filter and CRT with white phosphor is able to create good color hue saturation but also at a significantly reduced resolution. For example, three color fields must be produced during the same period as a normal 60Hz field, thereby dividing the video bandwidth for each color by three.

A liquid crystal array can produce a color image using a low operating voltage, but it can provide only a marginal picture element (pixel) density, i.e. less than 800 by 800 elements. One commercial device is known that uses a linear array of light emitting diodes viewed via a vibrating mirror and a simple magnifier. Although this is a low cost and low power alternative, the display is monochrome and limited in line resolution to the number of elements which can be incorporated into the linear array.

Both the CRT and liquid crystal display generate real images which are relayed to the eyes through an infinity optical system. The simplest optical system allows a user to view the image

- 3 -

source through a simple magnifier lens. For fields of view greater than 30°, this approach leads to a number of problems including light loss and chromatic aberrations. Further, these optics are bulky and heavy.

Virtual projection optical designs create an aerial image somewhere in the optical path at an image plane which is then viewed as an erect virtual image via an eye piece or objective lens. This approach increases the flexibility by which the image from the image source can be folded around the user's head for a head mounted display system, but large fields of view require large and bulky reflective and refractive optical elements.

In addition to resolution limitations, current systems also have bandwidth deficiencies. Bandwidth is a measure of how fast the display system can address, modulate or change the light emissions of the display elements of the image source. The bandwidth of the display image source is computed on the basis of the number of elements which must be addressed over a given period of time. Addressing elements temporally is needed to refresh or maintain a perceived luminance of each element taking into account the light integration dynamics of retinal receptors and the rate at which information is likely to change. The minimum refresh rate is a function of the light adaptive state of the eye, display luminance, and pixel persistence, i.e. the length of time the picture element produces light after it has been addressed. Minimum refresh rates of 50 to 60 times a second are typically needed for television type displays. Further, an update rate of at

- 4 -

least 30Hz is needed to perceive continuous movement in a dynamic display or in a presentation in which the display image is stabilized as a result of head movement. Refreshing sequentially, i.e. one element at a time, 40 million picture elements at a 60hz rate would require a video bandwidth of 2.4GHz. Bandwidth requirements can be reduced by interlacing which tricks the eye in its perception of flicker but still requires that all of the elements of the image source be addressed to achieve a minimum update rate of 30Hz or 1.2GHz bandwidth. Typical television broadcast quality bandwidths are approximately 8MHz, or two orders of magnitude less than the 1.2GHz. High resolution computer terminals have 1400 by 1100 picture elements which are addressed at a 70Hz non-interlaced rate which is the equivalent to a bandwidth of approximately 100MHz.

SUMMARY OF THE INVENTION

In accordance with the present invention, the disadvantages of prior virtual image displays systems have been overcome. The virtual image display system of the present invention includes the use of an optical fiber to provide a point source of light that is scanned onto a retina of a user's eye to create thereon a panoramic, high resolution, color virtual image.

More particularly, the virtual image display system of the present invention includes a source of light that is modulated with video information. A scanning system including a horizontal microscanner and a vertical microscanner scans the

- 5 -

video modulated light onto a retina of the user's eye. A single, monofilament optical fiber has an entrance aperture into which light from the source is directed, the optical fiber coupling the light to the scanning system in order to provide a point source of light at the exit aperture of the optical fiber.

The source of light utilized with the present invention may be a laser wherein the optical fiber provides a point source of light at its exit aperture without any astigmatism that may be present in the light emanating from the laser. The optical fiber also allows the laser and video modulation circuitry to be positioned remotely from the scanning system to minimize the weight of the scanning system when mounted on a user's head.

Alternatively, the source of light utilized with the system of the present invention may include a light emitting diode. Known light emitting diodes have a light emission area that is typically too large to provide a point source of light for very high resolution image generation. The optical fiber, in accordance with the present invention, receives light at its entrance aperture from the light emitting diode and provides a point source of light at its exit aperture.

It is also noted that the source of light utilized with the system of the present invention may include multiple light emitters that are colored, for example a red light emitter, a blue light emitter and a green light emitter wherein each light emitter is directly modulatable with respective red, blue and green video information. The colored light from each source may be directed

- 6 -

into an individual optical fiber associated with the emitter. Alternatively, the colored light from each of the emitters may be combined and thereafter coupled to the entrance aperture of the optical fiber so as to provide a point source of color, video modulated light at the exit aperture of the fiber. These and other objects, advantages and novel features of the present invention as well as details of an illustrated embodiment thereof will be more fully understood from the following description and the drawings.

BRIEF DESCRIPTION OF THE DRAWING

- Fig. 1 is a block diagram of the virtual retinal display of the present invention;
- Fig. 2 is a block diagram illustrating one embodiment of the virtual retinal display depicted in Fig. 1;
- Fig. 3 is a second embodiment of the virtual retinal display of Fig. 1 utilizing color;
- Fig. 4 is a block diagram illustrating another embodiment of a color virtual retinal display in accordance with the present invention;
- Fig. 5 is a diagram of an LED array utilized in a further embodiment of the virtual retinal display of the present invention employing parallel photon generation and modulation;
- Fig. 6 is an illustration of a laser phased array;
- Fig. 7 is an illustration of a microscanner utilized in accordance with the present invention;
- Fig. 8 is an illustration of another

- 7 -

microscanner that may be utilized in accordance with the present invention; and

5 Fig. 9 is a diagram illustrating the optical system of another embodiment of the virtual retinal display of Fig. 1 utilizing an optical fiber;

Fig. 10 is a side view of a portion of the optical fiber depicted in Fig. 9 having an end directly abutting a LED; and

10 Fig. 11 is a side view illustrating an optical fiber having a funnel-like end adjacent to a photon generator.

DESCRIPTION OF THE PREFERRED EMBODIMENTS

15 The virtual retinal display 10 of the present invention as shown in Fig. 1 utilizes photon generation and manipulation capable of creating a panoramic, high resolution, color image that is projected directly onto the eye of a user. The virtual retinal display does not use a display
20 that generates a real image such as a CRT, LCD or LED array as in prior virtual image displays. Instead, photons modulated with video information are scanned directly onto the retina 22 of a user's eye 20 to produce the perception of an
25 erect virtual image. Because the virtual retinal display 10 does not utilize a real image display, the virtual retinal display 10 is small in size and weight and is therefore suitable to be easily mounted on the user's head as a head mounted
30 display.

More particularly, as shown in Fig. 1, photons from a photon generator 12 are modulated

- 8 -

with video information by a modulator 14. The modulated photons are scanned in a first direction and in a second direction generally perpendicular to the first direction by a scanner 16 to create
5 a raster of photons that is projected directly onto the retina 22 of the eye 20 of the user by projection optics 18 to produce the perception of an erect virtual image. Although not necessary, it is desirable to employ an eye tracking system
10 24 to reposition the scanned raster of light as the pupil 26 of the eye 20 moves so that the light ray bundles are coincident with the entrance pupil of the eye. The eye tracking system 24 can also be used as feedback to change the image or the
15 focus of the image scanned onto the retina as the eye moves so that the user perceives that he is focusing on a different portion of a panoramic scene as he shifts his eye. It is noted that the dotted lines shown entering the eye 20 in Fig. 1
20 as well as in subsequent figures represents the range of scanning and not the instantaneous ray bundle.

The photon generator 12 may generate coherent light such as a laser or it may generate non-
25 coherent light such as by utilizing one or more LEDs. Further, beams of red, green and yellow or blue light may be modulated by RGY or RGB video signals to scan colored photons directly onto the user's eye. In order to reduce the bandwidth of
30 the virtual retinal display, multiple monochromatic beams or multiple groups of colored beams can be modulated and scanned in parallel onto the retina where the video information used to modulate the photons is divided into different

- 9 -

sectors or regions and each beam or group of colored beams is associated with a different sector of video information as described below. It is further noted that the functions performed by one or more of the photon generator 12, modulator 14, scanner 16 and projection optics 18 can be combined to be performed by fewer elements depending upon the actual components used in the system. For example, an acousto-optic deflector may be used to both modulate the light from the photon generator 12 and to scan the modulated light in at least one direction. Further, a laser phased array may be utilized to perform the functions of the photon generator, modulator and one or possibly two scanners as discussed below.

The components of the virtual retinal display 10 can be made small, compact and lightweight so that the virtual retinal display 10 can easily be mounted on the head of a user without requiring a helmet or an elaborate head mounting for structural support. Further, the photon generator 12 and modulator 14 can be separated from the scanner 16 and projection optics 18 so that only the scanner 16 and optics 18 need be mounted on the head of a user, the modulated photons being coupled to the scanner via a bundle of monofilament optical fibers, or a single monofilament optical fiber as described in detail below. In a preferred embodiment, microscanners are utilized to scan the photons, such microscanners being small, thin and deflected to scan the photons in response to an electrical drive or deflection signal. Suitable types of microscanners are described below and in United

- 10 -

States Patent Application Serial No. 08/329,508
filed October 26, 1994 assigned to the assignee of
the present invention and incorporated herein by
reference. The photon generator, modulator and
5 scanner can therefore be made very small such as
 $1\frac{1}{2}$ inch high by $1\frac{1}{2}$ inch wide by $\frac{1}{4}$ inch thick or
less with a weight of less than an ounce so as to
facilitate a head mounting for the virtual retinal
display 10.

10 In accordance with one embodiment of the
present invention as shown in Fig. 2, high
resolution scanners are used to deflect a beam of
light both horizontally and vertically in a two
dimensional raster pattern. No lens is used to
15 focus the beam to form a real image in front of
the eye. Instead, the lens 29 of the eye focuses
the beam to a point on the back of the retina, the
position of the beam point scanning the retina as
the scanner 16 scans the modulated photons. The
20 angle of deflection of the collimated light beams
corresponds to the position of the focused spot on
the retina for any given eye position just as if
an image were scanned at an infinite distance away
from the viewer. The intensity of the light is
25 modulated by the video signal in order to create
an image of desired contrast. Therefore, when the
user's eye moves, the user will perceive a
stationary image while he looks at different parts
of the scene. The lateral extent of the image is
30 proportional to the angle of the scan. Anamorphic
optics are used as necessary to align the scanned
photons and to scale the perceived image. By
forming a reduced image of the scanner aperture,
a proportionately larger scanning angle is

- 11 -

yielded. Other than this, the size of the scanner image is irrelevant as long as the light enters the eye.

5 More particularly, as shown in Fig. 2, light or photons from a photon generator 12 is projected through a cylindrical lens 30 and a spherical lens 32 to an acousto-optical deflector 34 that scans the photons in a first or horizontal direction. The cylindrical lens spreads the light beam from 10 the photon generator 12 horizontally so that it fills the aperture of the acousto-optical deflector 34. The spherical lens 32 horizontally collimates the light which impinges onto the acousto-optical deflector 34.

15 The acousto-optical deflector 34 is responsive to a video signal on a line 36 that is applied as a drive signal to a transducer of the acousto-optic deflector 34 to modulate the intensity of the photons or light from the photon 20 generator 12 and to scan the modulated light from the photon generator 12 in a first direction or horizontally. The video signal on line 36 is provided by a video drive system generally designated 38 that includes a video controller 42. 25 The video controller 42 may include a video generator such as a frame buffer 40 that provides video signals on a line 56 and respective horizontal sync and vertical sync signals. The video controller 42 may also include a 30 microprocessor that operates in accordance with software stored in a ROM 46 or the like and utilizes a RAM 48 for scratch pad memory. The horizontal sync signal from the video generator 40 is converted to a ramp wave form by a ramp

- 12 -

generator 50, the horizontal sync ramp waveform is applied to a voltage controlled oscillator 52 that provides a signal in response to the ramp input having a frequency that varies such that it chirps. The output from the voltage controlled oscillator 52 is applied to an amplifier 54 the gain of which is varied by the video data signal 56 output from the video generator 40 so that the video signal 36 output from the amplifier 54 has an amplitude that varies in accordance with the video information on line 56 and that has a frequency that varies in a chirped manner. The video signal on line 36 is applied to a drive transducer of the acousto-optical deflector 34. Varying the amplitude of the drive signal on line 36 with the video information causes the acousto-optical deflector 34 to modulate the intensity of the light from the photon generator 12 with the video information. Varying the frequency of the drive signal on line 36 in a chirped manner causes the acousto-optical deflector to vary the angle at which the light is deflected thereby so as to scan the light in a first or horizontal direction.

A spherical lens pair 64 and 68 images the horizontally scanned light or photons onto a vertical scanner 62 wherein a cylindrical lens 68 spreads the light vertically to fill the aperture of the vertical scanner 62. The vertical scanner 62 may for example be a galvanometer. The vertical sync signal output from the video generator 40 is converted to a ramp waveform by a ramp generator 58 and amplified by an amplifier 60 to drive the vertical scanner 62. The speed of scanning of the vertical scanner 62 is slower than

- 13 -

the scanning of the horizontal scanner 34 so that the output of the vertical scanner 62 is a raster of photons. This raster of photons is projected directly onto the eye 20 of the user by projection
5 optics taking the form of a toroidal or spherical optical element 72 such as a refractive lens, mirror, holographic element, etc.

The toroidal or spherical optical element 72 provides the final imaging and reduction of the scanned photons. More particularly, the toroidal
10 or spherical optical element relays the scanned photons so that they are coincident near the entrance pupil 26 of the eye 20. Because a reduced image of the scanner aperture is formed,
15 the deflection angles are multiplied in accordance with the Lagrange invariant wherein the field of view and image size are inversely proportional. As the size of the scanned photons, i.e. the exit aperture of the virtual retinal display are
20 reduced, the field of view of the image perceived by the eye increases.

The optical element 72 can be an occluding element that does not transmit light from outside of the display system. Alternatively the optical
25 element 72 can be made light transmissive to allow the user to view the real world through the element 72 wherein the user perceives the scanned virtual image generated by the display 10 superimposed on the real world. Further, the
30 optical element 72 can be made variably transmissive to maintain the contrast between the outside world and the displayed virtual image. A passively variable light transmissive element 72 may be formed by sandwiching therein a

- 14 -

photochromic material that is sensitive to light to change the light transmissiveness of the element as a function of the ambient light. An actively variable light transmissive element 72
5 may include a liquid crystal material. A photosensor can be used with such an element to detect the amount of ambient light wherein a bias voltage across the liquid crystal material is varied in accordance with the detected light to
10 actively vary the light transmissiveness of the element 72.

The system described thus far with respect to Fig. 2 is monocular. In order to provide a stereoscopic system a second virtual retinal
15 display 10' may be utilized in parallel with the first retinal display 10, the second virtual retinal display 10' projecting scanned photons modulated with the appropriate video information directly on the second eye 20' of the user. This
20 provides a medium for binocular depth information so that displayed objects appear at different depths. Each pixel of the object, however, appears at the same distance from the user which can create a possible conflict between the
25 stereoscopic cue and the monocular cue where the stereoscopic cue deals with the positioning of the object with respect to each eye and the monocular cue deals with the focus of the light of the object being imaged on the retina. More
30 particularly, in prior virtual image display systems, each monocular image plane was typically focused at optical infinity causing each of the pixels within the virtual image to appear at one distance. However, the combination of two prior

- 15 -

monocular systems to form the binocular view created a possible conflict between the distance cues and the focus or accommodation cue.

5 The virtual retinal display of the present invention overcomes this problem by utilizing an accommodation cue 70 either in the monocular display system 10 or in the binocular display system formed of displays 10 and 10'. The accommodation cue 70 is a focusing or depth cue
10 that is controlled to vary the focus or convergence or divergence of the scanned photons rapidly to control the depth perceived for each picture element of the virtual image. Therefore in accordance with the present invention true
15 depth perception is obtained by modulating each pixel for depth individually such as by controlling the focus, i.e. the convergence or divergence, of the individual pixel. The accommodation cue 70 includes a reflective surface
20 that changes shape rapidly. For example, a miniature mirror having a deformable membrane whose shape is altered as the membrane is charged and discharged may be used to form the accommodation cue. The deformation of the
25 membrane is thus varied by an electrical drive signal to control the convergence or divergence of each pixel for depth. The drive of the accommodation cue 70 is provided by the video controller 42 which may, for example, store a Z
30 axis video information buffer in the memory 48 or in the video generator 40 in addition to the two dimensional video information in a typical frame buffer.

- 16 -

A further embodiment of the virtual retinal display 10 of the present invention is depicted in Fig. 3 for scanning colored photons directly onto the retina of a user's eye. As shown in Fig. 3, the photon generator 12 includes colored lasers or LEDs such as a red photon generator 80, a green photon generator 82 and a blue photon generator 84. If a blue photon generator is unavailable, a yellow photon generator may be utilized. The colored photons from the generators 80, 82 and 84 are modulated with respective RGB video information from the video generator 40 and then combined by a beam combiner/dispersion precompensator 86. The output of the beam combiner/dispersion precompensator 86 is projected onto the horizontal scanner 34 by the cylindrical lens 30 and the spherical lens 32. It is noted that the horizontal scanner may be other than the acousto-optic scanner shown in Fig. 2. For example, a resonant mechanical scanner or various types of microscanners as discussed below may be used for the horizontal scanner. The horizontally scanned color modulated photons output from the scanner 34 are projected onto a dispersion compensator 88 the output of which is projected onto a prism before being projected onto the vertical scanner 62 by the spherical lens pair 64 and 68.

The colored photon raster as scanned from the output of the vertical scanner 62 is projected by a spherical lens 92 onto an offset mirror 96 which is moved by the eye tracker 106 so as to position the raster of photons directly onto the entrance pupil 26 of the eye 20 as the pupil moves. In one

- 17 -

embodiment, a beam splitter 100 directs an image reflected off of the cornea of the eye 20 to a lens 102 and a position sensing diode 104 that is coupled to the eye tracker 106 to detect the position of the pupil 26. In response to the detected position of the pupil, the eye tracker correctly positions the offset mirror(s) 96 so that the exit pupil or aperture of the virtual retinal display is approximately aligned with the entrance pupil of the eye and/or to adjust the scan angle to reflect changed video information as described below.

The instantaneous position of the pupil 26 as determined by the eye tracker 106 is also communicated to the video controller 42 so that the microprocessor 44 can direct video information to modulate the colored light where the video information reflects a change in the direction of the user's view. More particularly, the detected pupil position is used by the microprocessor 44 to position a "visible window" on the video information stored in the frame buffer 40. The frame buffer 40 may for example store video information representing a panoramic view and the position of the visible window determines which part of the view the user is to perceive, the video information falling within the visible window being used to modulate the light from the photon generator 12.

It is noted that, because the acousto-optical deflector 34 diffracts red light more than green light and diffracts green light more than blue light, this variation in the diffraction must be compensated for. In accordance with the present

- 18 -

invention, this variation in diffraction may be compensated for by appropriately delaying via delays 108, 110 and 112 the RGB video signals that are coupled to the respective red, green and blue photon generators 80, 82 and 84 to modulate the red, green and blue photons with the appropriate red, green and blue video information.

In another embodiment of the virtual retinal display of the present invention as shown in Fig. 4, composite video or RGB video signals are received by a digital video scan converter 120 and separated into multiple compartments that represent sectors or regions of an image to be scanned. Multiple video drive signals output from the video amplifiers 124 representing each sector are used to modulate the light from the photon generator 12 in parallel. The photon generator may consist of either arrays of lasing diodes or arrays of high luminance light emitting diodes. Multiple beams of red, green and yellow or blue light are modulated with the video signals in parallel for each of the divided sectors or regions and then relayed directly or by monofilament optical fibers 131 to a microscanner 16. The microscanner 16 essentially performs two functions. First, the microscanner scans the multiple color beams associated with each sector or region in two axes to create a raster of light on the retina and not an aerial image, there being no image plane between the photon generator 12 and the eye 20. Second, the microscanner 16 functions to position the scanned light relative to the instantaneous entrance pupil 26 of the eye as sensed by the eye tracker 24.

- 19 -

More particularly, the scanner 16 includes a first microscanner 132 that is responsive to an X axis deflection signal output from a deflection amplifier 136 to scan the color beams in a horizontal direction where the amplifier 136 is driven by the horizontal sync signal from a scan generator 122. A second microscanner 134 is responsive to a Y deflection signal from the deflection amplifiers 136 as driven by the vertical sync or deflection drive from the scan generator 122 to scan the horizontally scanned color photons in the vertical direction. A scan collimation lens 140 receives a two dimensionally modulated light field that is projected onto a tri-color combiner 142. The combiner 142 in turn projects the scanned light onto a Maxwellian-view optical system 148. The optical system 148 projects the scanned colored photons onto a raster position deflector which may include two axis galvo mirrors that in turn project the scanned light onto a toroidal optical element such as a combiner 152 having a trichoric coating, the toroidal combiner 152 projecting the scanned color photons directly onto the eye 20.

For eye tracking, the eye tracker 24 includes an infrared light source which illuminates the surface of the eye with low intensity infrared light either directly or indirectly as shown. The surface of the eye is viewed through the raster position deflector 150 via the combiner 142, a lens 140 and a charge coupled device, CCD, array 146. The signals from the CCD sensor 146 are processed by a pupil position processor 154 to generate null signals, ΔH and ΔV , that are coupled

- 20 -

to respective color deflection amplifiers 158 and to the raster positioning mirrors 150 so as to cause the scanned photons to follow the pupil of the user's eye 20.

5 An example of a light emitting diode array suitable for use in the present invention is illustrated in Fig. 5. If an X-Y visual field is considered to be composed of an array of 2,000 x 2,000 resolvable spots or pixels, the spots must
10 be refreshed 50 times per second so as to have an information bandwidth of approximately 200MHz. High brightness LEDs typically have a power bandwidth curve that starts to roll off above 2MHz. This result is essentially an R-C product
15 limitation related to the diffusion capacitance of a heavily forward-biased p-n junction. In order to meet the bandwidth requirements of the system, a linear array of 50 to 100 LED pixels per color are utilized. Using a red, green and blue LED
20 scheme would require 50-100 LEDs of each of these three colors. As shown in Fig. 5, an array 200 includes LED chips 201, 202, 203 - N wherein each LED chip includes an LED active area 205. The LED active area may include a GaAsP alloys and a Si₃ N₄
25 dielectric overlayer.

A laser phased array as illustrated in Fig. 6 functions to perform photon generation, video modulation and scanning in at least one direction. The laser phased array includes a thin film wave
30 guide 210, phase modulator electrodes 212, a cleaned coupled cavity 214 and laser cavities 216, the array emitting a coherent beam of about 10mW power. When two closely spaced lasers are fabricated in the same chip of material, their

- 21 -

optical fields become coupled so that the processes of optical emission in the two devices are correlated and coherent. The result is a well defined phase front emitted from the laser pair.

5 In the laser phased array 220 having a number of laser cavities 216, the optical beam is phase coherent if the lasers are spaced within 10 microns of each other. This resolution can be achieved by photolithographic techniques. The

10 electro-optic modulator works by modifying the index of refraction of the wave guide medium 210 through which the optical beam must travel before being launched into free space. By separating the electrical contacts 212 for each modulator, the

15 relative phase of each individual laser in the array can be modified by the modulator. For an appropriate series of modulation voltages, the phase front of the laser array coupled beam can be modified so that the emitted beam is launched at

20 an angle to the normal exit direction. With the appropriate series of modulation voltages the laser beam can be scanned in a given direction. It is possible to construct a two axis laser phased array so that an additional scanner is not

25 needed to scan the laser in a perpendicular direction.

An example of a microscanner 132, 134 for scanning photons is illustrated in Fig. 7. The microscanner includes an actuator 230. The

30 actuator 230 is a piezoelectric bimorph cantilever that is capable of three dimensional motion in response to an electrical drive signal. By controlling the deflection of the cantilevered actuator with the appropriate drive signals, the

- 22 -

actuator 230 deflects the photons incident thereto to scan the photons.

Another example of a microscanner that can be made extremely small is shown in Fig. 8, the microscanner having a curved reflective surface that translates to scan light impinging thereon in one direction. More particularly, the microscanner 240 includes a base or actuator 242 formed of a piezoelectric material with a substrate 244 formed on the actuator 242 wherein the substrate 244 has a curved reflective surface 246. In response to a varying drive signal the piezoelectric actuator and the substrate 244 translate in the direction of the arrows 248 so as to scan the light impinging on the surface 246 of the substrate in a first direction generally perpendicular to the direction 248 of translation. A second microscanner 250 scans the light impinging thereon in a second direction perpendicular to the first direction so as to scan a raster image directly onto the retina of a user's eye.

In still another embodiment of the present invention as depicted in Fig. 9, one single mode, monofilament optical fiber 300 or single strand optical fiber is utilized to couple light from a light source such as the photon generator 12 to the scanning system 16. The single monofilament optical fiber 300 includes an entrance aperture 302 leading into the single core 304 of the fiber 300, the core 304 extending the length of the optical fiber to an exit aperture 306. The exit aperture 306 of the single monofilament optical fiber 300 may be extremely small. For example the

- 23 -

diameter of the exit aperture may be 10 microns or less and preferably on the order of 3.5 microns so as to provide a point source of light for input to the scanning system 16.

5 The photon generator 12, as described above, may generate coherent light such as a laser. In a laser embodiment of the system depicted in Fig. 9, the optical fiber 300 allows the laser source as well as the video source and video modulation
10 portion of the system to be located remotely from the scanning system 16. The optical fiber 300 has a further advantage when the laser source is a laser diode or other laser generator that produces
15 astigmatic light. More particularly, laser diodes typically generate astigmatic light which, when scanned onto the retina of a user's eye will not produce a round pixel as desired but a distorted pixel such as an elliptical pixel. The optical
20 fiber 300 when used with such a laser source will convert the astigmatic laser light into a circular point source at the exit aperture 306 of the fiber 300 so as to obtain circular or round pixels when the light is scanned onto the retina.

 The photon generator 12 as shown in Fig. 9
25 may also include a light emitting diode (LED). LEDs do not generate coherent light. Further, the light emission area of an LED is typically too large for very high resolution image generation as is required for certain applications of the
30 display system. Although optics, such as lenses, can be used to shrink the apparent size of an LED light source, use of such optics can result in a loss of intensity and further, an increase in the optical path length so as to increase the overall

- 24 -

size of the display system. However, when the LED light is coupled to a single mode, monofilament optical fiber 300, the exit aperture 306 of the fiber 300 will form a point source of light that is small enough for very high resolution image generation. It is noted that a typical LED might have a light emission area 308 that is on the order of 500 microns. In accordance with the present invention, the optical fiber 300 allows the very large light emission area of the LED to be reduced to less than 10 microns and preferably on the order of 3.5 microns for a fiber 300 having a core 304 diameter on that order.

A lens such as the lens 310 shown in Fig. 9 may be used to focus the light from a laser, a LED or other type of photon generator 12 into the entrance aperture 302 of the optical fiber 300. Alternatively, as shown in Fig. 10, the end 312 of the optical fiber containing the entrance aperture 302 may abut directly against the photon generator 12 which is shown as an LED 314. As seen in Fig. 10, the diameter or area of the entrance aperture 302 of the optical fiber is much smaller than the light emission area 308 of the LED 314. Fig. 11 depicts a further embodiment for coupling the light from the photon generator 12 to the optical fiber 300. In this embodiment, the optical fiber 300 is formed with a funnel-like end portion 316 leading into entrance aperture 302 of the small, constant diameter core 304 of the optical fiber 300 with an entrance aperture 302. An entrance aperture 318 of the fiber's funnel portion 316 has a diameter that is greater than the diameter of the entrance aperture 302 of the constant diameter

- 25 -

core portion 320 of the optical fiber 300. The funnel end portion 316 of the optical fiber shown in Fig. 11 may directly abut the photon source 12 or, alternatively, it may be positioned merely in close proximity thereto.

5 The light from the point source formed at the exit aperture 306 of the optical fiber 300 is coupled to a horizontal microscanner 332 of the scanning system 16 via a lens 330. The light incident to the horizontal microscanner 332 is directed onto a vertical microscanner 334 and scanned onto the retina of a user's eye via a lens 336. The distance between the exit aperture 306 of the optical fiber 300 and the lens 330 may be adjusted so that the light output from the lens 330 converges to form an image plane 340 between the output of the scanning system 16 and the user's eye. The lens 336 is a collimating lens that directs the light onto the user's retina. In order to adjust the field of view of the virtual retinal display depicted in Fig. 9, the lens 330 and the lens 336 may be moved closer together or farther apart. Because the system of the present invention is very compact including only minimal optical elements, the lenses 330 and 336 may be ganged together in a manner so that the lenses can be moved together, inwardly towards each other or outwardly away from each other so that the user does not have to make separate adjustments thereto. This can be accomplished by utilizing a zoom lens mounting structure of the like for the lenses 330 and 336.

It is further noted, that the source of light input to the entrance aperture 302 of the optical

- 26 -

fiber 300 may include a red light emitter, a blue light emitter and a green light emitter to provide a full color system. Preferably, each of these light emitters is directly modulatable with video information. However, separate video modulators may also be utilized with the colored light emitters to modulate the red light with red video information, the blue light with blue information and the green light with green video information. The light from each of the colored emitters may be directed into an optical fiber associated with that individual light emitter, each of the optical fibers being coupled to a single optical fiber 300 so as to provide at the exit aperture 306 thereof a point source of color, video modulated light. Alternatively, the colored light from each of the emitters may be combined as described above prior to being input to the entrance aperture 302 of the optical fiber 300.

Many modifications and variations of the present invention are possible in light of the above teachings. Thus, it is to be understood that, within the scope of the appended claims, the invention may be practiced otherwise than as described hereinabove.

What is claimed is:

- 27 -

CLAIMS

1. A virtual image display system comprising:

a source of light, said light being modulated with video information;

5 a scanning system for scanning said light onto a retina of a user's eye; and

a single, monofilament optical fiber having an entrance aperture and an exit aperture, said optical fiber coupling light from said source to
10 said scanning system to provide a point source of light at the exit aperture of said optical fiber.

2. A virtual image display system of claim 1 wherein said source of light includes a laser.

3. A virtual image display system of claim 1 wherein said source of light includes a light emitting diode.

4. A virtual image display system of claim 1 wherein said source of light has an area of light emission; and the exit aperture of said optical fiber has an area that is smaller in size
5 than said light emission area of the light source.

5. A virtual image display system of claim 1 wherein said source of light includes a red light emitter, a blue light emitter and a green light emitter; and a light combining system for
5 combining light from each of said red, blue and green light emitters.

- 28 -

6. A virtual image display system of claim 5 wherein light output from said combining system is coupled to the entrance aperture of said optical fiber.

7. A virtual image display system of claim 5 wherein at least one of said light emitters is directly modulated with said video information.

8. A virtual image display system of claim 1 wherein said source of light is a source of coherent light.

9. A virtual image display system of claim 1 wherein said source of light is a source of non-coherent light.

10. A virtual image display system of claim 1 including a lens disposed between said source of light and said entrance aperture of said optical fiber to focus light from said source onto said entrance aperture.

11. A virtual image display system of claim 1 wherein the entrance aperture of said optical fiber directly abuts said source of light.

12. A virtual image display system of claim 1 including a lens disposed between the exit aperture of said optical fiber and said scanning system to couple light from said exit aperture to said scanning system.

- 29 -

13. A virtual image display system of claim 12 wherein said lens converges light to form an image plane between an output of said scanning system and the user's eye.

14. A virtual image display system of claim 12 including a single lens disposed between an output of said scanning system and the user's eye.

15. A virtual image display system of claim 5 including means coupled to the output of at least one of said light emitters for modulating said light with video information.

16. A virtual image display system comprising:

a source of non-coherent light, said source having an area of light emission and said light being modulated with video information;

a scanning system for scanning said non-coherent light onto a retina of a user's eye;

a single, monofilament optical fiber having an entrance aperture and an exit aperture, said optical fiber coupling light from said source to said scanning system and said exit aperture being smaller than the area of light emission of said source.

17. A virtual image display system of claim 16 wherein said source of light includes a light emitting diode.

- 30 -

18. A virtual image display system of claim 17 wherein said light emitting diode is directly modulated with said video information.

19. A virtual image display system of claim 16 wherein said source of light includes a red light emitter, a blue light emitter and a green light emitter; and a light combining system for
5 combining light from each of said red, blue and green light emitters.

20. A virtual image display system of claim 19 wherein light output from said combining system is coupled to the entrance aperture of said optical fiber.

21. A virtual image display system of claim 16 including a lens disposed between said source of light and said entrance aperture of said optical fiber to focus light from said source onto
5 said entrance aperture.

22. A virtual image display system of claim 16 wherein the entrance aperture of said optical fiber directly abuts said source of light.

23. A virtual image display system of claim 16 including a lens disposed between the exit aperture of said optical fiber and said scanning
5 system to couple light from said exit aperture to said scanning system.

24. A virtual image display system of claim 23 wherein said lens converges light to form an

- 31 -

image plane between an output of said scanning system and the user's eye.

25. A virtual image display system of claim 23 including a single lens disposed between an output of said scanning system and the user's eye.

26. A virtual image display system of claim 19 including an individual optical fiber portion associated with each of said red, blue and green light emitters.

27. A method of generating a virtual image comprising:

modulating light emitted from a source of light with video information;

5 positioning an entrance aperture of a single monofilament optical fiber relative to said source of light to couple light from said source to an exit aperture of said optical fiber;

10 positioning a lens adjacent to said exit aperture of said optical fiber to receive light therefrom; and

scanning light from said lens onto a retina of a user's eye to form an image of said video information on the retina.

28. The method of claim 27 wherein said lens positioning step positions said lens at a distance from said exit aperture of the optical fiber to cause said lens to converge light at an image plane on which said light is scanned, said image plane being outside of the user's eye.

5

- 32 -

29. The method of claim 27 wherein said light is emitted from a laser.

30. The method of claim 27 wherein said light is emitted from a light emitting diode.

31. The method of claim 30 wherein said entrance aperture of the optical fiber abuts said light emitting diode.

32. The method of claim 27 wherein said modulating step includes emitting a red light; modulating said red light with red video information; emitting a blue light; modulating said blue light with blue video information; emitting a green light; modulating said green light with green video information; combining said modulated red light, blue light and green light to form the light emitted from said light source; and wherein said optical fiber positioning step includes positioning the entrance aperture of said optical fiber to receive said combined red, blue and green light.

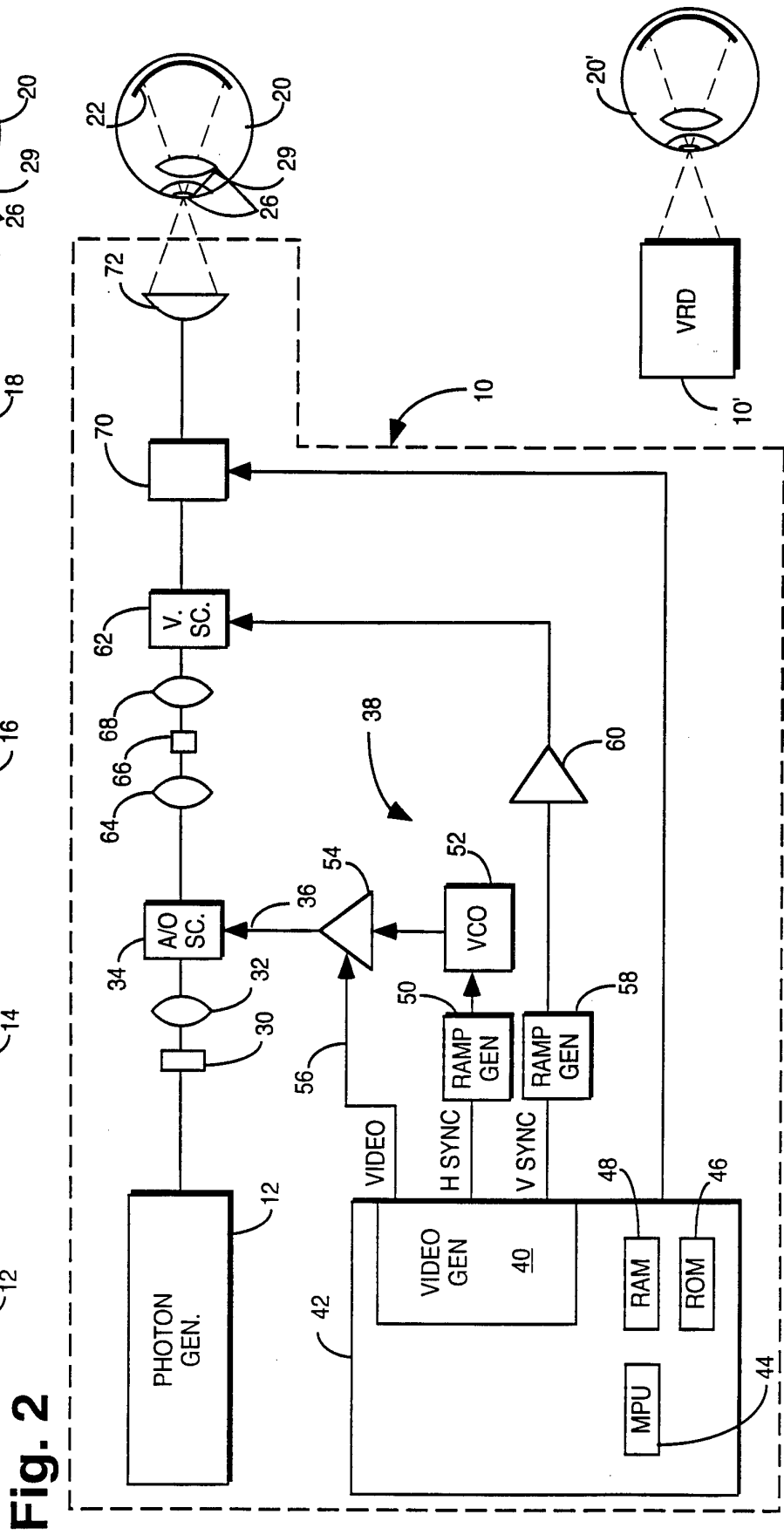
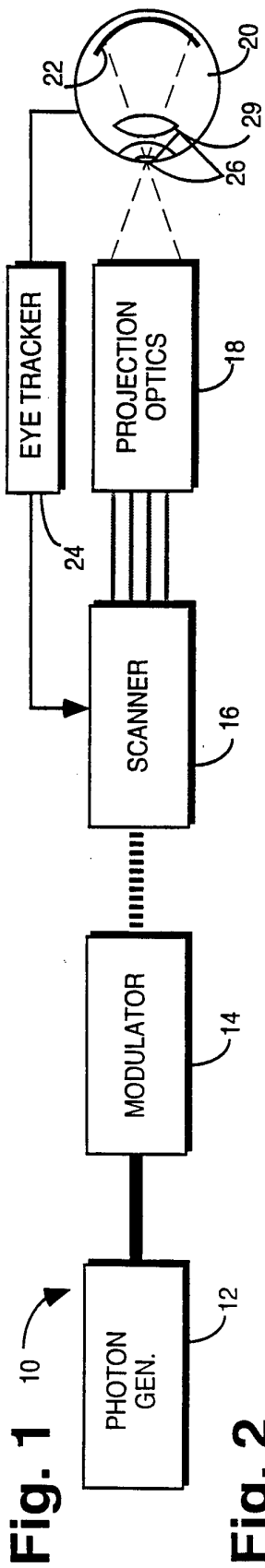

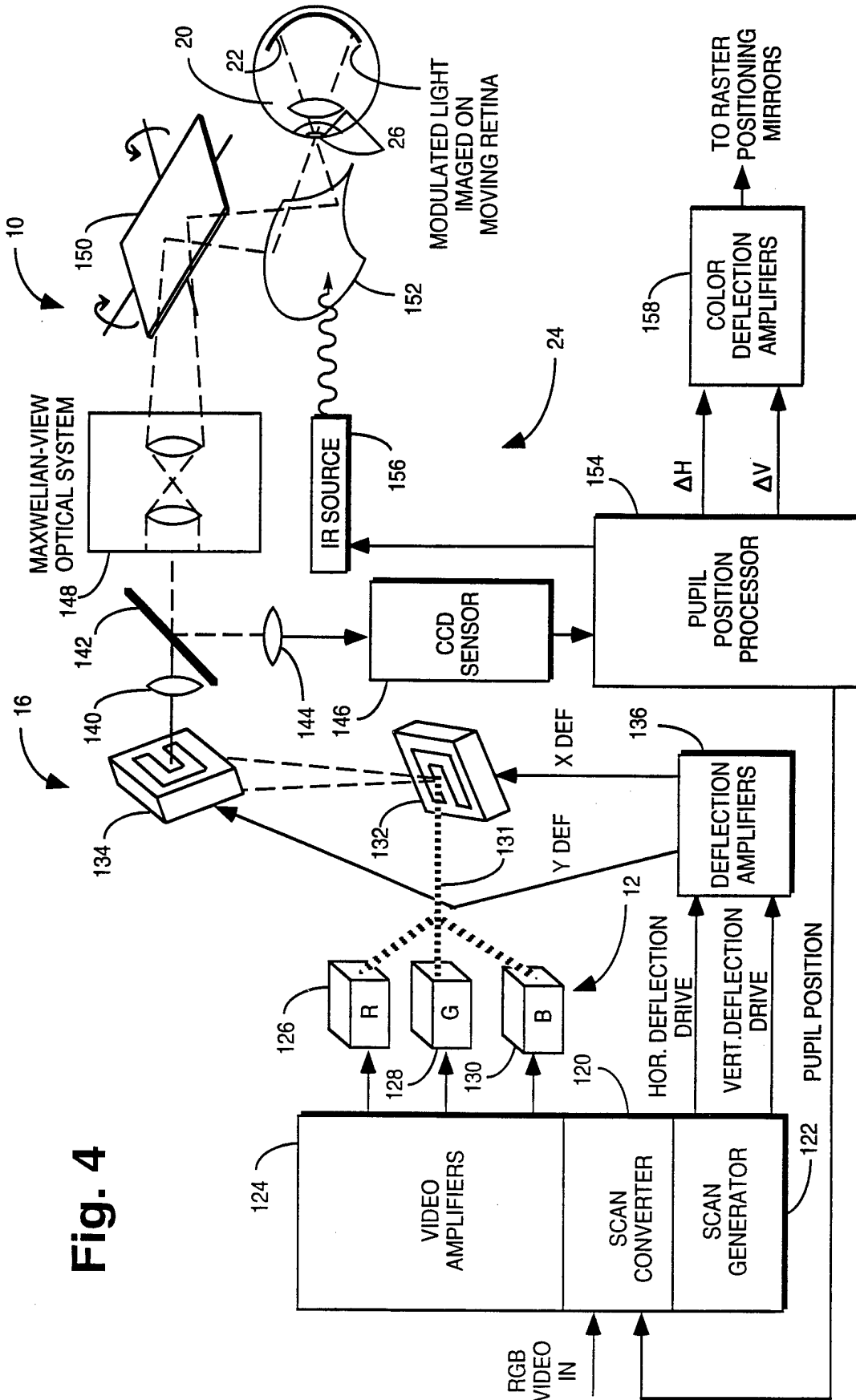

Fig. 4

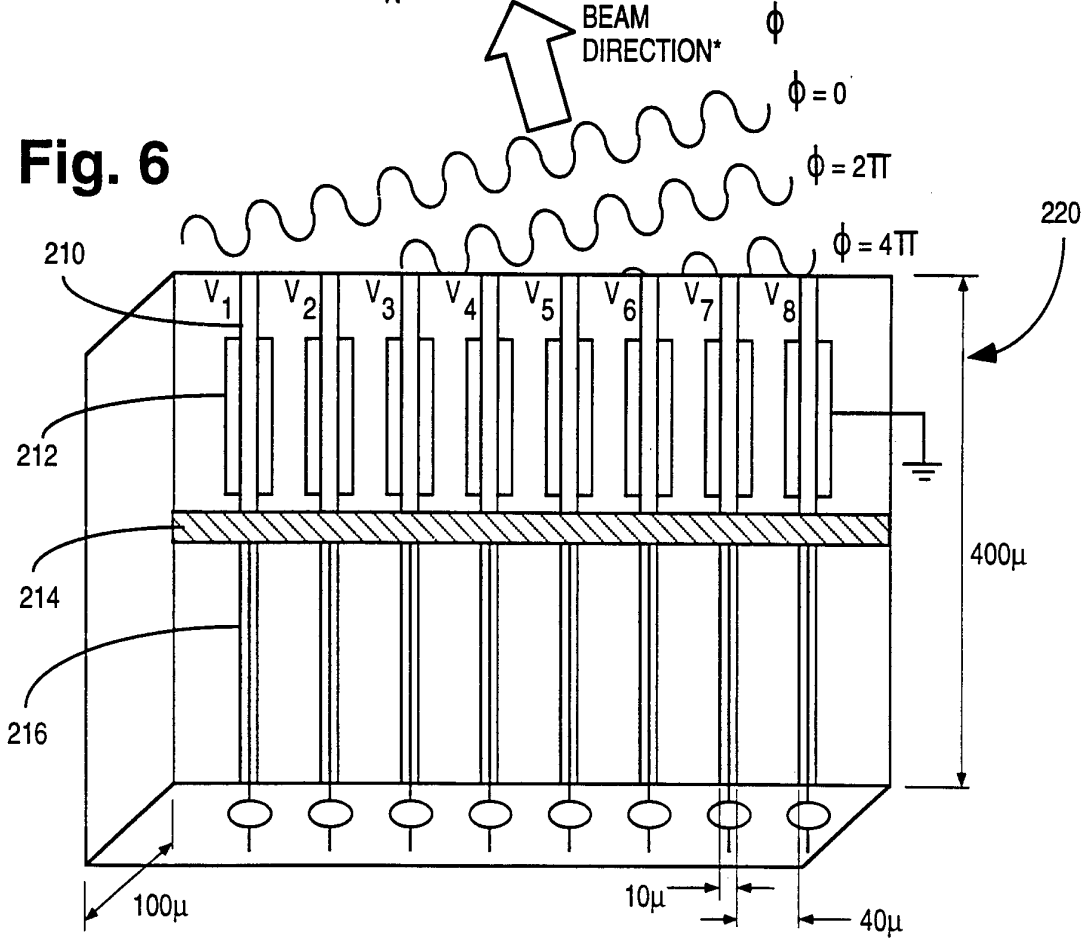
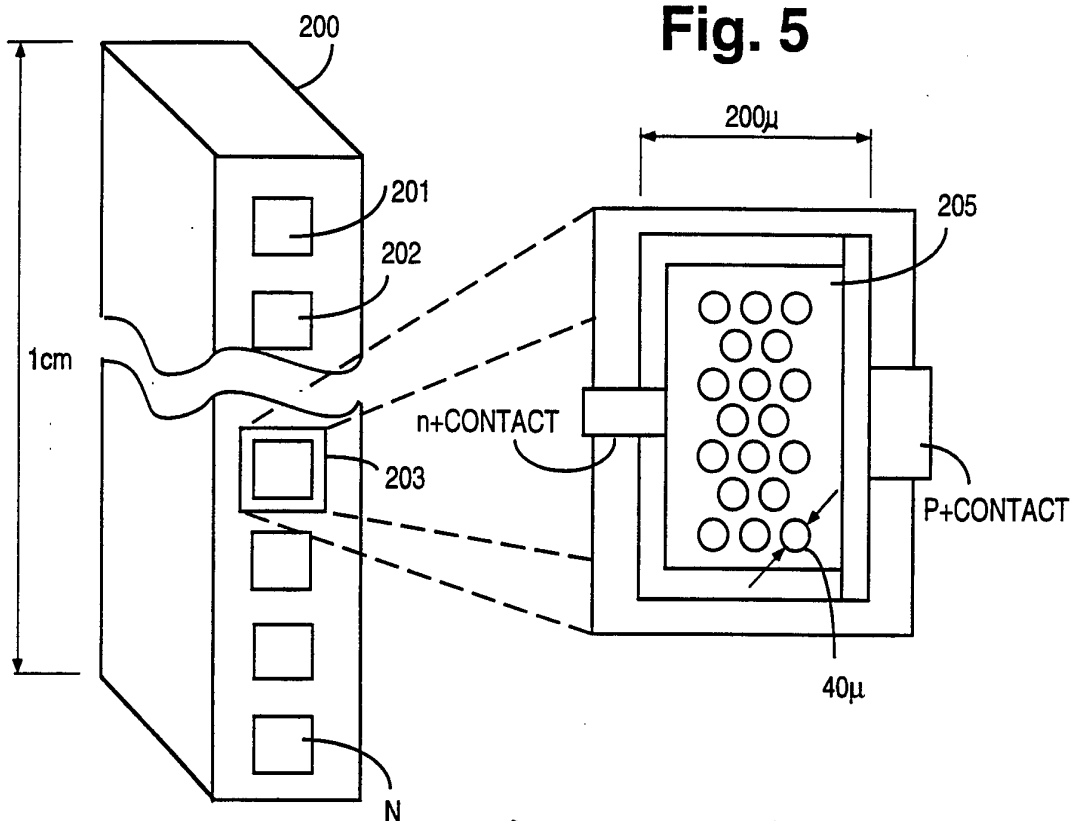

Fig. 7

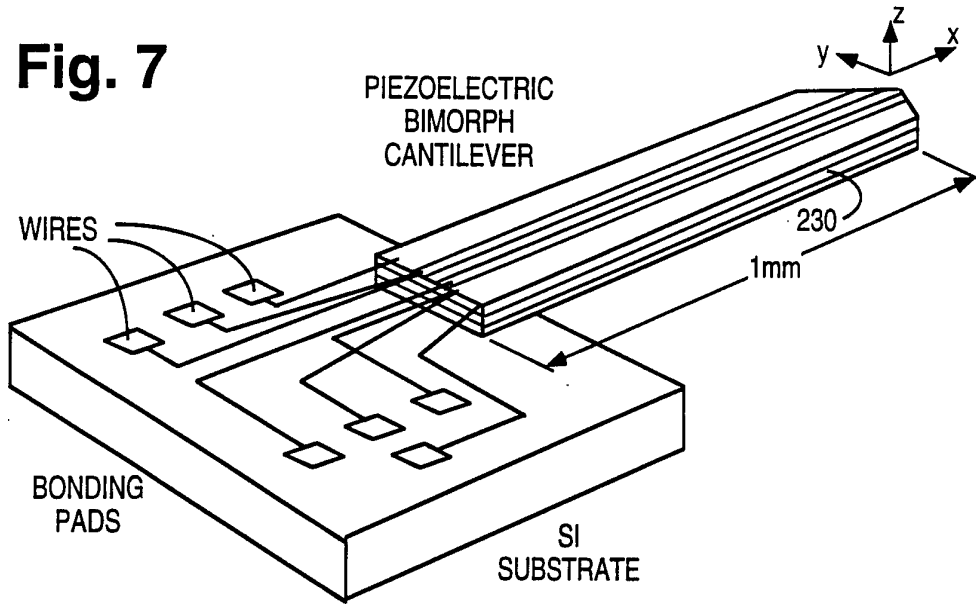

Fig. 8

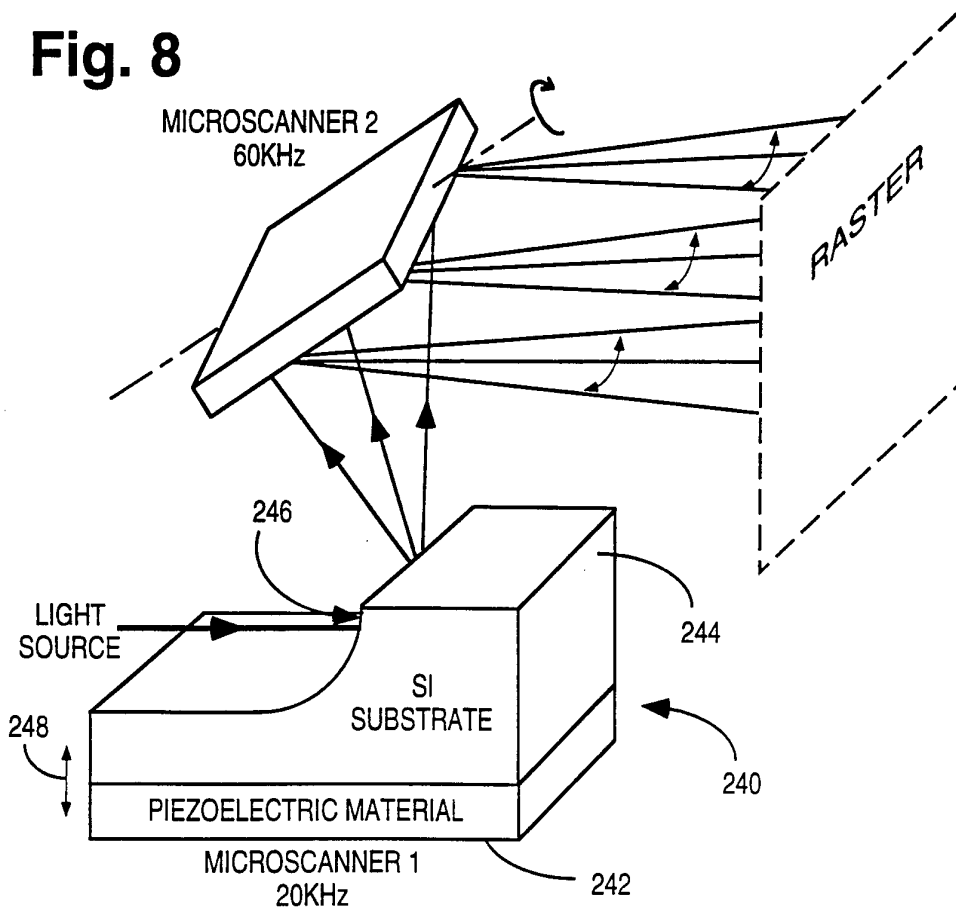

Fig. 9

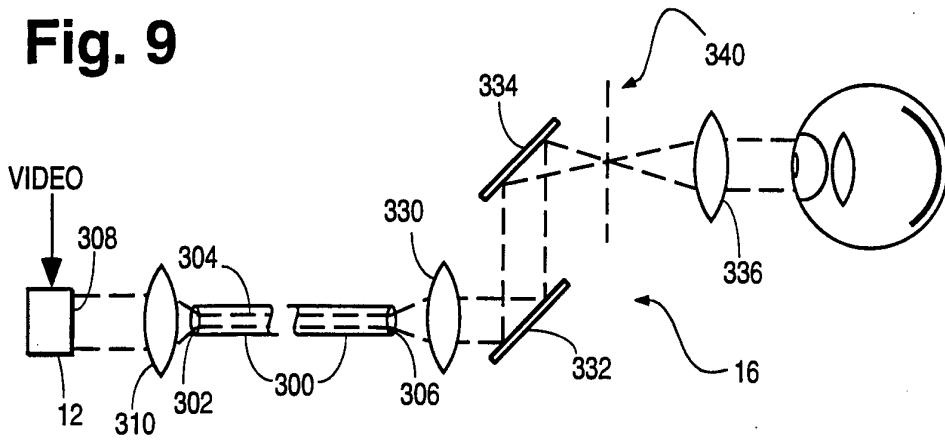

Fig. 10

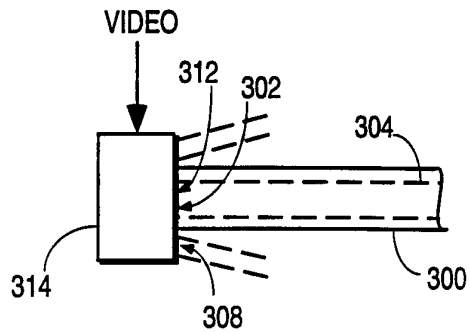
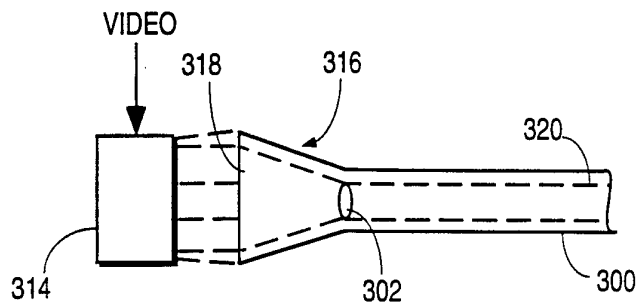

Fig. 11



INTERNATIONAL SEARCH REPORT

International application No.
PCT/US96/05431

A. CLASSIFICATION OF SUBJECT MATTER IPC(6) :G09G 3/02 US CL :345/8 According to International Patent Classification (IPC) or to both national classification and IPC		
B. FIELDS SEARCHED Minimum documentation searched (classification system followed by classification symbols) U.S. : 345/7-9; 348/53; 359/630; and 340/980 Documentation searched other than minimum documentation to the extent that such documents are included in the fields searched Electronic data base consulted during the international search (name of data base and, where practicable, search terms used)		
C. DOCUMENTS CONSIDERED TO BE RELEVANT		
Category*	Citation of document, with indication, where appropriate, of the relevant passages	Relevant to claim No.
A	US, A, 4,878,046 (SMITH) 31 OCTOBER 1989, figures 1 and 5, the abstract, and column 7 line 40 to column 8 line 17.	1-32
A	US, A, 4,310,849 (GLASS) 12 JANUARY 1982, figures 1 and 2, the abstract, and column 4 lines 21-30.	1-32
A	US, A, 3,833,300 (RYMES) 03 SEPTEMBER 1974, figure 1, the abstract, and column 2 line 13-29.	1-32
<input type="checkbox"/> Further documents are listed in the continuation of Box C. <input type="checkbox"/> See patent family annex.		
* Special categories of cited documents:	*T*	later document published after the international filing date or priority date and not in conflict with the application but cited to understand the principle or theory underlying the invention
A document defining the general state of the art which is not considered to be part of particular relevance	*X*	document of particular relevance; the claimed invention cannot be considered novel or cannot be considered to involve an inventive step when the document is taken alone
E earlier document published on or after the international filing date	*Y*	document of particular relevance; the claimed invention cannot be considered to involve an inventive step when the document is combined with one or more other such documents, such combination being obvious to a person skilled in the art
L document which may throw doubts on priority claim(s) or which is cited to establish the publication date of another citation or other special reason (as specified)	*&*	document member of the same patent family
O document referring to an oral disclosure, use, exhibition or other means		
P document published prior to the international filing date but later than the priority date claimed		
Date of the actual completion of the international search	Date of mailing of the international search report	
27 JUNE 1996	17 JUL 1996	
Name and mailing address of the ISA/US Commissioner of Patents and Trademarks Box PCT Washington, D.C. 20231 Facsimile No. (703) 305-3230	Authorized officer V. JEFFERY A. BRIER Telephone No. (703) 305-4700	