

July 28, 1964

R. G. OEHMIG
ADJUSTABLE SEAL STRIP
Filed Jan. 17, 1962

3,142,097

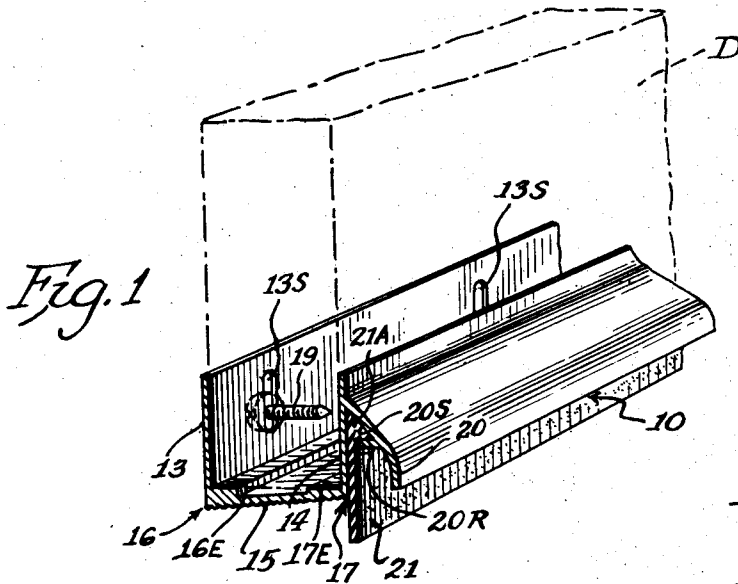

Fig. 3

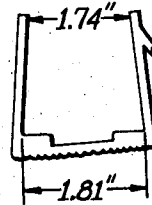
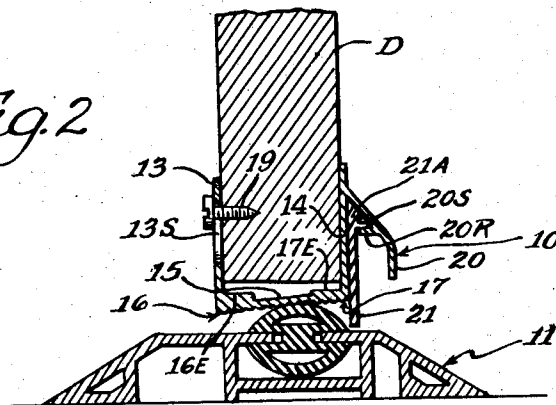

Fig. 2



Inventor
Robert G. Oehmig

By
Mann, Brown and McWilliams
Attys.

1

3,142,097

ADJUSTABLE SEAL STRIP

Robert G. Oehmig, 8059 S. Winchester, Chicago, Ill.

Filed Jan. 17, 1962, Ser. No. 166,899

3 Claims. (Cl. 20-69)

This invention relates to an adjustable seal strip for application to a swinging door to facilitate establishing and maintaining proper sealing relation with a weather-stripped threshold and more particularly the invention is concerned with an adjustable seal strip of this type that also serves as a kick plate and splash shield.

Many forms of adjustable thresholds have been devised for accommodating door mounting clearance variations. The potential range of adjustment in this prior art approach is limited and in many instances the actual user is not aware of the possibilities of adjusting the thresholds. It frequently occurs that the mounting clearance at the base of the door will change with settling of the building and this aggravates the clearance problems described above and increases the need for simple adjustment of the seal.

The principal object of the present invention is to provide a door mounted seal strip of a one piece door pinching configuration to facilitate adjustment for various door mounting clearances.

Another object of the invention is the provision of such an adjustable door mounted seal strip that may also function as a kick plate.

Still another object of the invention is the provision of such an adjustable door mounted seal strip incorporating a protective splash shield.

A further object of the invention is the provision of an all-purpose door mounted seal strip of low-cost extruded construction.

Other objects and advantages will become apparent during the course of the following description.

In the accompanying drawings forming a part of this specification and in which like numerals are employed to designate like parts throughout the same;

FIG. 1 is a perspective view of an adjustable seal strip of this invention,

FIG. 2 is a transverse sectional view illustrating the seal strip as applied to a door and adjusted for sealing engagement with a weather-stripped threshold; and

FIG. 3 is a schematic cross section of the adjustable seal strip, showing the taper of the side walls from the base to the upper extremities of the side walls. It is, of course, obvious that to achieve the pinching action hereinafter described both walls may be tapered or either wall may extend vertically with the opposite wall tapering inwardly.

Referring now to the drawings, the seal strip of this invention is shown separately in FIG. 1 as indicated at 10 and is shown applied to the lower edge of a door and adjustably positioned for sealing engagement with a weather-stripped threshold 11 in FIG. 2.

In accordance with this invention the seal strip 10 is in the form of an elongated one piece thin walled metal extrusion and preferably is of aluminum and has a wall thickness on the order of 0.06" to accommodate limited flexing required for pinching engagement against the door sides. The seal strip 10 has a length dimension corresponding to the width dimension of the door D on which it is mounted and it is comprised of lengthwise coextensive inner and outer vertical face plate portions, 13 and 14, respectively, having their lower ends in integral connection to opposite lateral extremities of a base plate portion 15 to define a generally U-shaped cross-sectional configuration for the strip. The corner junctures 16 and 17 defined between the base plate and each of the vertical face plates are provided with integral enlargements 16E and 17E that

2

function as abutment stops for contact with the underside of the door when the strip is fully applied.

In a typical strip configuration, in accordance with this invention, the horizontal distance between the face plate portions is about 1.81" at the bottom and 1.74" at the top to develop a pinching action against the door sides. The reinforced corner junctures yieldably resist spreading of the strip and thus tend to maintain the strip in its original pinching U-shape.

To permit secure attachment of the seal strip to the lower edge of the door, the inner face plate 13 is provided with a series of horizontally spaced vertically elongated anchor slots 13S.

The strip 10 may conveniently be applied to the door after the weather-stripped threshold is in place and the door has been hung. One end of the strip is registered with the free lower corner of the door and the strip is advanced edgewise until it embraces the full width of the lower door edge. The pinching action of the strip maintains it at any selected position. Therefore, the strip 10 may readily be displaced vertically until its inclined base plate portion 15 is brought into sealing contact with the weather-stripped threshold 11. Wide head anchor screws 19 are then tightened in the anchor slots 13S to hold the strip in its adjusted position such as is illustrated in FIG. 2.

In the preferred form of sealing strip illustrated herein for purposes of disclosure, the one piece strip construction includes an integral coping 20 depending from the outer face plate portion. The coping 20 originates along a line located adjacent but slightly below the upper end of the outer face plate 14 and projects in a direction leading generally outwardly and downwardly to provide a splash shield. The splash shield and outer face plate cooperably define a downwardly opening internal cavity and the coping includes a generally inwardly projecting horizontal rib 20R disposed within this cavity and defining a dovetail mounting slot 20S extending lengthwise throughout its upper extremity to underlie the uppermost region of the coping 20. A separate sweep element 21 of flexibly distortable material is provided with an enlarged anchorage 21A at its upper end mating with and supportingly interlocked in the dovetailed mounting slot. This sweep projects below the outer corner juncture 17 of the strip and supplements the action of the splash shield. The sweep 21 may be of a molded plastic, such as vinyl, and is preferably enterable endwise into the space between the face plate 14 and the coping 20.

Since the sweep 21 and splash shield 20 bear a fixed relation to the inclined base plate portion 15, the adjustment of the position of the base plate portion automatically adjusts the sweep and splash shield to a new position of appropriate relation to the threshold. The unitary construction in combination with the self-holding action resulting from the pinching configuration of the strip facilitates any adjustments that are required and, in particular, permits application of the strip with anchoring screws on only one of its side panels.

It should be understood that the description of the preferred form of the invention is for the purpose of complying with Section 112, Title 35, of the U.S. Code and that the appended claims should be construed as broadly as the prior art will permit.

What is claimed is:

1. An adjustable seal strip for a door and comprising an elongated one-piece thin-walled extrusion comprising a base portion integrally connected to inner and outer wall portions each having a planar interior face to define a generally U-shaped cross-sectional configuration, the interior faces of said wall portions being convergent in the direction of their upper extremities to develop a pinching action on the door, one of said wall portions having verti-

3

cally elongated anchor slots to receive a fastener in adjustable relation for attachment of the strip to the door at various vertical locations, said base portion having an underface inclined from the horizontal in a direction crosswise of the strip, said outer wall portion having an integrally connected coping projecting generally outwardly and downwardly to provide a splash shield.

2. The seal strip of claim 1 wherein said coping includes an internal rib providing a dovetail mounting slot extending lengthwise beneath the upper region of the coping for cooperation with a sweep element disposed between said outer face portion and said coping.

3. An adjustable seal strip for a door and comprising an elongated one-piece thin-walled metal extrusion of a generally U-shaped cross-sectional configuration that tapers upwardly to develop a pinching action on the door, said strip comprising a generally laterally oriented base plate portion and lengthwise co-extensive outer and inner vertical face plate portions having lower ends in continuous integral connection to opposite lateral extremities of said base plate portion to define a substantially full-length outer corner juncture between the base plate portion and the outer face plate portion, and a substantially full-length inner corner juncture between the base plate portion and the inner face plate portion, each of said junctures having an integral internal corner enlargement giving sufficient rigidity to the configuration to yieldably maintain the desired pinching action, one of said face plate portions having vertically elongated anchor slots to receive a fastener in adjustable relation for attachment of

4

the strip to the door at various vertical locations, said outer face plate portion having an integrally connected coping projecting generally outwardly and downwardly from along a location adjacent its upper end to provide a splash shield, said coping including an internal rib providing a dovetail mounting slot extending lengthwise beneath the upper region of the coping, and a sweep element disposed between said outer face plate portion and said coping, said sweep element including an anchorage mating with and supportingly interlocked in said dovetail mounting slot.

References Cited in the file of this patent

UNITED STATES PATENTS

15	738,163	Clutter -----	Sept. 8, 1903
	1,149,355	Faires -----	Aug. 10, 1915
	1,527,739	Leach -----	Feb. 24, 1925
	1,834,031	Macklanburg -----	Dec. 1, 1931
	2,095,669	Kunkel -----	Oct. 12, 1937
20	2,541,421	Hunter -----	Feb. 13, 1951
	2,739,357	Seabrook -----	Mar. 27, 1956
	2,790,213	Smith -----	Apr. 30, 1957
	2,837,787	Wright -----	June 10, 1958
	2,933,781	Cornell -----	Apr. 26, 1960
25	2,934,802	Shekter -----	May 3, 1960
	3,064,319	Miller -----	Nov. 20, 1962

FOREIGN PATENTS

	230,042	Australia -----	Mar. 12, 1959
30	504,228	Great Britain -----	Nov. 17, 1938