



- (51) International Patent Classification:
B65D 88/16 (2006.01) B65D 33/00 (2006.01)
B65D 33/14 (2006.01)
- (21) International Application Number:
PCT/US2013/046775
- (22) International Filing Date:
20 June 2013 (20.06.2013)
- (25) Filing Language: English
- (26) Publication Language: English
- (30) Priority Data:
61/663,339 22 June 2012 (22.06.2012) US
- (72) Inventor; and
- (71) Applicant : NESS, Danny [US/US]; P.O. Box 9098,
Metairie, Louisiana 70055 (US).
- (74) Agents: D'SOUZA, Vanessa, M. et al.; Garvey, Smith,
Nehrbass & North, L.L.C., 3838 N. Causeway Blvd., Suite
3290, Metairie, Louisiana 70002-1767 (US).

- (81) Designated States (unless otherwise indicated, for every kind of national protection available): AE, AG, AL, AM, AO, AT, AU, AZ, BA, BB, BG, BH, BN, BR, BW, BY, BZ, CA, CH, CL, CN, CO, CR, CU, CZ, DE, DK, DM, DO, DZ, EC, EE, EG, ES, FI, GB, GD, GE, GH, GM, GT, HN, HR, HU, ID, IL, IN, IS, JP, KE, KG, KN, KP, KR, KZ, LA, LC, LK, LR, LS, LT, LU, LY, MA, MD, ME, MG, MK, MN, MW, MX, MY, MZ, NA, NG, NI, NO, NZ, OM, PA, PE, PG, PH, PL, PT, QA, RO, RS, RU, RW, SC, SD, SE, SG, SK, SL, SM, ST, SV, SY, TH, TJ, TM, TN, TR, TT, TZ, UA, UG, US, UZ, VC, VN, ZA, ZM, ZW.
- (84) Designated States (unless otherwise indicated, for every kind of regional protection available): ARIPO (BW, GH, GM, KE, LR, LS, MW, MZ, NA, RW, SD, SL, SZ, TZ, UG, ZM, ZW), Eurasian (AM, AZ, BY, KG, KZ, RU, TJ, TM), European (AL, AT, BE, BG, CH, CY, CZ, DE, DK, EE, ES, FI, FR, GB, GR, HR, HU, IE, IS, IT, LT, LU, LV, MC, MK, MT, NL, NO, PL, PT, RO, RS, SE, SI, SK, SM, TR), OAPI (BF, BJ, CF, CG, CI, CM, GA, GN, GQ, GW, KM, ML, MR, NE, SN, TD, TG).

[Continued on next page]

(54) Title: BULK BAG APPARATUS

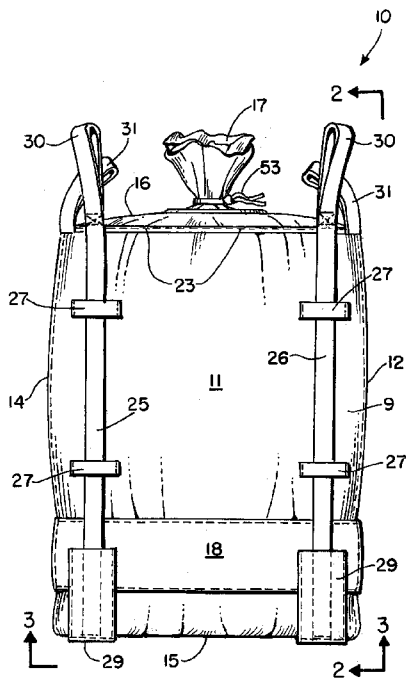

FIG. 1.

(57) Abstract: A bulk bag apparatus provides a bag having a bottom wall, a top portion, side walls and seams joining each side wall to another side wall, and bag corners at the seams. First and second lifting slings are rigged to the bag, the slings being spaced apart and not intersecting, preferably parallel to each other. A portion of the bottom wall of the bag is exposed in between the slings so that the bottom wall can be cut such as for discharging the contents of the bag. Bottom guides are provided on the bag bottom portion. Side guides are provided on the bag side walls. Corner guides are provided that each extend from the bottom wall to a side wall and across a bottom corner of the bag. Each guide provides an open ended channel that is receptive of a lifting sling. Each corner has an eyelet attached to the bag top portion at the corner.



Published:

— with international search report (Art. 21(3))

— before the expiration of the time limit for amending the claims and to be republished in the event of receipt of amendments (Rule 48.2(h))

PATENT APPLICATION

TITLE OF THE INVENTION

BULK BAG APPARATUS

INVENTOR: NESS, Danny, a US citizen, of P.O. Box 9098, Metairie, LA, 70055, US.

CROSS-REFERENCE TO RELATED APPLICATIONS

This is a non provisional patent application of US Provisional Patent Application Serial No. 61/663,339, filed 22 June 2012.

Priority of US Provisional Patent Application Serial No. 61/663,339, filed 22 June 2012, hereby incorporated herein by reference, is hereby claimed.

STATEMENT REGARDING FEDERALLY SPONSORED RESEARCH OR DEVELOPMENT

Not applicable

REFERENCE TO A "MICROFICHE APPENDIX"

Not applicable

BACKGROUND OF THE INVENTION

1. Field of the Invention

The present invention relates to bulk bags that are able to carry heavy weights of granular material, powdered material or other solid material, or material that is slurried. More particularly, the present invention relates to an improved bulk bag apparatus that uses a unique sling arrangement in combination with improvements to the bag structure.

2. General Background of the Invention

The following table lists examples of patents that have issued for bulk bag devices.

Patent No.	Title	Issue Date MM-DD-YYY
2,212,390	Double Capacity Bag	08-20-1940
3,870,358	Apparatus for Manually Raising and Lowering Bulky Packages	03-11-1975
3,961,655	Bulk Material Containers	06-08-1976
4,224,970	Collapsible Receptacle for Flowable Materials	09-30-1980
4,597,102	Intermediate Bulk Container	06-24-1986

BRIEF SUMMARY OF THE INVENTION

The apparatus of the present invention solves the problems confronted in the art in a simple and straightforward manner. What is provided is a bulk bag with improved construction including a better load carrying configuration.

The present invention includes a bulk bag apparatus, comprising a bag having a bottom wall, a top portion, side walls and seams joining each side wall to another side wall, and bag corners at the seams. First and second lifting slings are rigged to the bag, the slings being spaced apart and not intersecting. A portion of the bottom wall can be exposed in between the slings. Bottom guides can be on the bag bottom that position the slings on the bottom. Side guides can be on the bag side walls that position the slings on the side walls. Corner guides can each extend from the bottom wall to a side wall. Each said guide provides an open ended channel that is receptive of a said first or second lifting sling. Each corner can have an eyelet attached to the bag top portion corner.

In one embodiment, the slings are removable from the guides.

In one embodiment, the top portion has an area, a top panel attached to the side walls and a fill opening in the top panel that is smaller than the said area.

In one embodiment, the slings have a load capacity of in excess of 10,000 pounds (4,536 kg).

In one embodiment, the slings are spaced apart laterally at a distance of between 6 and 24 inches (15 and 61 cm).

The present invention includes a bag for transporting bulk material, comprising a bag member that includes a bottom wall, side walls, bag corners, and a top wall. A plurality of eyelets can be secured to upper parts of said sidewalls at the corners and next to the top portion. An inlet tube can be secured to the top wall defining a material inlet. A plurality of sling guides can be stitched to the bag member including bottom sling guides, side sling guides and corner sling guides. Each sling guide provides an open ended channel that is sized and shaped to receive a lifting sling and position the slings upon the bag member. A pair of lifting slings can be attached to the sling guides, each lifting sling having loop end portions, each lifting sling removably secured to the bag member by passing through a plurality of said guides, wherein each sling passes through one or more bottom sling guides, one or more side sling guides of two opposing side walls, and at least one corner sling guide. The lifting slings do not overlap. Each

sling can be of a length that places the loops at an elevation near the top wall of the bag member.

In one embodiment, the slings are spaced apart a distance of between about 6 and 24 inches (15 and 61 cm).

In one embodiment, each sling occupies the channel of a pair of said corner sling guides.

In one embodiment, each sling occupies the channel of a pair of said side sling guides.

The present invention includes a method of transporting bulk material from a beginning locale to a final locale, comprising the steps of providing a bag member that includes a bottom wall, side walls, bag corners, a top wall, a plurality of sling guides stitched to the bag including bottom sling guides, side sling guides and corner sling guides, each sling guide providing an open ended channel that is sized and shaped to receive a lifting sling. The method provides rigging a pair of lifting slings to the bags by passing each lifting sling through a plurality of said sling guides, each sling having loop end portions, wherein the slings do not overlap. The bag can be filled at the beginning locale with a volume of bulk material. The bag can be transported from the beginning locale to the final locale, wherein the bag is lifted with the lifting slings, wherein the slings are rigged to the sling guides. The bag can be cut with a cutting device that cuts the bottom wall at a position in between the slings.

In one embodiment, the slings are maintained in generally spaced apart positions continuously along the lengths of the slings.

In one embodiment, the slings are maintained in generally spaced apart positions parallel to one another.

The present invention includes a bulk bag apparatus, comprising a bag having a bottom wall, a top portion, side walls and seams joining each side wall to another side wall, and bag corners at the seams. A band can encircle the bag, the band being spaced above the bottom wall, the band continuously abutting the bag at the side walls. First and second lifting slings can be rigged to the bag, the slings being spaced apart and not intersecting. A portion of the bottom wall can be exposed in between the slings. Bottom guides can be on the bag bottom. Corner guides can each extend from the bottom wall to a side wall. Each said guide provides an open ended channel that is receptive of a said first or second lifting sling.

In one embodiment, the slings are removable from the guides.

In one embodiment, the top portion has an area, a top panel attached to the side walls and

a fill opening in the top panel that is smaller than the said area.

In one embodiment, the slings have a load capacity of in excess of 10,000 pounds (4,536 kg).

The present invention includes a bag for transporting bulk material, comprising a bag member that includes a bottom wall, side walls, bag corners, and a top wall. An inlet tube can be secured to the top wall defining a material inlet. A plurality of sling guides can be stitched to the bag including guides that extend from the bottom panel to a said side wall. Each sling guide provides an open ended channel that is sized and shaped to receive a lifting sling. A pair of lifting slings can be attached to the sling guides, each lifting sling having liftable end portions, each lifting sling removably secured to the bag member by passing through a plurality of said guides. Each sling can be of a length that places the sling end portions at an elevation near the top wall of the bag member.

In one embodiment, each sling occupies the channel of a pair of said guides that are corner sling guides that are attached to both the bottom wall and a said side wall.

The present invention includes a method of transporting bulk material from a beginning locale to a final locale, comprising the steps of providing a bag member that includes a bottom wall, side walls, bag corners, a top wall, and a plurality of sling guides stitched to the bag. A pair of lifting slings can be rigged to the bags by passing each lifting sling through a plurality of said sling guides and under the bag bottom wall, each sling having lifting end portions, and wherein the slings do not overlap. The bag can be filled at the beginning locale with a volume of bulk material. The bag can be transported from the beginning locale to the final locale, wherein the bag is lifted with the lifting slings, wherein the slings are rigged to the sling guides. The bag can be cut with a cutting device that cuts the bottom wall at a position in between the slings.

In one embodiment, the slings are maintained in generally spaced apart positions continuously along the lengths of the slings.

In one embodiment, the slings are maintained in generally spaced apart positions parallel to one another.

A bulk bag apparatus provides a bag having a bottom wall, a top portion, side walls and seams joining each side wall to another side wall, and bag corners at the seams. First and second lifting slings are rigged to the bag, the slings being spaced apart and not intersecting, preferably parallel to each other. A portion of the bottom wall of the bag is exposed in between the slings

so that the bottom wall can be cut such as for discharging the contents of the bag. Bottom guides are provided on the bag bottom portion. Side guides are provided on the bag side walls. Corner guides are provided that each extend from the bottom wall to a side wall and across a bottom corner of the bag. Each guide provides an open ended channel that is receptive of a lifting sling. Each corner has an eyelet attached to the bag top portion at the corner.

BRIEF DESCRIPTION OF THE SEVERAL VIEWS OF THE DRAWINGS

For a further understanding of the nature, objects, and advantages of the present invention, reference should be had to the following detailed description, read in conjunction with the following drawings, wherein like reference numerals denote like elements and wherein:

Figure 1 is a front, elevation view of a preferred embodiment of the apparatus of the present invention;

Figure 2 is a side view of a preferred embodiment of the apparatus of the present invention;

Figure 3 is a bottom view of a preferred embodiment of the apparatus of the present invention;

Figure 4 is an elevation view of a preferred embodiment of the apparatus of the present invention;

Figure 5 is an elevation view of a preferred embodiment of the apparatus of the present invention;

Figure 6 is an elevation view of a preferred embodiment of the apparatus of the present invention;

Figure 7 is a bottom view of a preferred embodiment of the apparatus of the present invention;

Figure 8 is a schematic view of a knife that can be used to cut the bottom of a bag;

Figure 9 is a perspective view of a preferred embodiment of the apparatus of the present invention after the bag has been emptied and lifting slings removed;

Figures 10, 11 and 12 are fragmentary sectional views showing a preferred embodiment of the apparatus of the present invention.

DETAILED DESCRIPTION OF THE INVENTION

Figures 1-9 show a preferred embodiment of the apparatus of the present invention designated generally by the numeral 10. Bag apparatus 10 employs a bag 9 that is constructed

of a plurality of four side walls, 11, 12, 13, 14 and a bottom wall 15. Top wall 16 is attached to each of the side walls 11-14. The top wall 16 provides an inlet or inlet opening 17 that can be closed using a tie, rope or other closure 53 (see figures 1, 2).

A lower end portion of the bag 9 provides a circumferential band 18 that is stitched to each of the side walls 11-14 and/or to the corners 19-22. There are preferably four stitched corners 19, 20, 21, 22. Each of the sides 11, 12, 13, 14 is attached using stitching to the top 16. An upper stitched periphery 23 joins the top 16 to the side walls 11-14. The bottom panel or wall 15 is attached to at least two of the side walls with lower stitched edges 24. The bottom wall can for example be a continuous rectangle of fabric that includes side walls 11, 13 and the bottom 15 (see figures 1 - 3).

A pair of lifting slings 25, 26 are provided. The bag 9 has a plurality of sling guides 27, 28, 29. In order to lift the bag 9, the slings 25, 26 are rigged to the bag 9 by threading each of the slings 25, 26 through a plurality of the sling guides 27, 28, 29. This arrangement can be seen in figures 1-7. In one embodiment, the lifting slings can be spaced 6 to 24 inches (15 and 61 cm) apart. Guides 27 are sling guides that are mounted to a side wall such as side wall 11 or 13. The guides 29 are corner sling guides that extend preferably from band 18 downwardly along a side 11 or 13 and to bottom panel or wall 15. Bottom sling guides 28 can be provided that are on the bottom 15 only (see figures 3, 7).

Each lifting sling 25, 26 has a pair of loop end portions 30, 31. These loop end portions 30, 31 can form a connection with a spreader or spreader frame 34 to which is attached to a lifting hook 33 and lifting line 32. Once supported by a lifting device such as a crane having a lifting line 32, the bag 9 can be lowered as illustrated by arrows 35 in figures 4 and 5 into a hopper 40 that is configured to receive the contents of the bag 9 such as bulk material, particulate material or the like.

The hopper 40 can provide a hopper interior 41 and an open top 42. In the crane and lifting line 32, bag 9 can be lowered into hopper 40 through hopper open top 42 and into hopper interior 41.

Hopper interior 41 can be fitted with a knife 43 which is known in the art (see figure 8). The knife 43 can provide a lance or projection 44 that is engaged by the bottom panel or bottom wall 15 of the bag 9 when it is lowered in the direction of arrows 35. The knife 43 then cuts the bag 9 bottom 15, forming cut 45, so that the contents of the bag 9 will fall into the hopper 40

interior 41 (see figures 5 - 7). The hopper 40 can provide a conically shaped bottom 36 with an outlet 37. In the drawings, discharged material 38 falls in the direction of arrow 39 from the bag apparatus 10 or bag 9 downwardly into another receptacle, tank, open pit or other selected receptacle (see figures 4 - 8).

In figure 9, an empty bag 9 is shown after knife 43 forms cut 45 in bottom 15 of bag 9 and the material 38 falls into another receptacle. Figure 9 also shows lifting sling 26 having been removed from sidewall sling guides 27 of bag 9 in the direction of arrows 54 and lifting string 25 being removed from sidewall sling guides 27 in the direction of arrow 55.

Figures 10 - 12 show various layers of material that comprise the bag 9 having walls 11 - 16. In figure 10, the bag 9 has a wall portion 11 - 16 comprised of four layers. In figure 11, the bag 9 has wall portions 11 - 16 comprised of three layers. In figure 12, the bag 9 has wall portions 11 - 16 comprised of five layers. In figure 10, the polypropylene layer 46 can be eight ounce (237 mL) polypropylene. The layer 47 can be polyethylene, the layer 48 foil and the layer 49 PET or polyethylene terephthalate. The layers 47, 48, 49 in figure 10 can have a combined thickness of about 8 mils (0.2 mm).

In figure 11, the layer 46 is polypropylene, for example eight ounce (237 mL) polypropylene. The layers 50 and 51 are barrier film such as Saranex 15 manufactured by Dow Chemical Company. Each layer 50, 51 can have a thickness of about 4 mils (0.1 mm). In figure 12, the layer 46 is polypropylene, for example eight ounce (237 mL) polypropylene. The layer 52 is a film layer such as Winflex 50 which is a commercially available LLDPE/LDPE film which can have a thickness of about 8 mils (0.2 mm). The layers 47, 48, 49 in figure 12 can be the same as in figure 10, namely polyethylene layer 47, foil layer 48, and PET layer 49. In figure 12 the layers 47, 48, 49 can have a combined thickness of about 8 mils (0.2 mm).

The following is a list of parts and descriptions used in the specification:

PARTS LIST:

PART NUMBER	DESCRIPTION
9	bag
10	bag apparatus
11	side wall
12	side wall

13	side wall
14	side wall
15	bottom wall
16	top wall
17	inlet or inlet opening
18	circumferential band
19	stitched corner
20	stitched corner
21	stitched corner
22	stitched corner
23	upper stitched periphery
24	lower stitched edge
25	lifting sling
26	lifting sling
27	sidewall sling guide
28	bottom sling guide
29	corner sling guide
30	loop end portion
31	loop end portion
32	lifting line
33	hook
34	spreader frame
35	arrow
36	conical bottom
37	outlet
38	discharged material
39	arrow
40	hopper
41	hopper interior
42	open top
43	knife

44	lance/projection
45	cut
46	polypropylene layer
47	polyethylene layer
48	foil layer
49	polyethylene terephthalate (PET)
50	barrier film
51	barrier film
52	film layer
53	tie/rope/closure
54	arrow
55	arrow

The foregoing embodiments are presented by way of example only; the scope of the present invention is to be limited only by the following claims.

CLAIMS

1. A bulk bag apparatus, comprising:
 - a) a bag having a bottom wall, a top portion, side walls, seams joining each side wall to another side wall, and bag corners at the seams;
 - b) first and second lifting slings rigged to the bag, the slings being spaced apart and not intersecting;
 - c) a portion of the bottom wall being exposed in between the slings;
 - d) bottom guides on the bag bottom that position the slings on the bottom;
 - e) side guides on the bag side walls that position the slings on the side walls;
 - f) corner guides that each extend from the bottom wall to a side wall;
 - g) each said guide providing an open ended channel that is receptive of a said first or second lifting sling; and
 - h) each corner having an eyelet attached to the bag top portion corner.
2. The bag apparatus of claim 1 wherein the slings are removable from the guides.
3. The bag apparatus of claim 1 wherein the top portion has an area, a top panel attached to the side walls and a fill opening in the top panel that is smaller than the said area.
4. The bag apparatus of claim 1 wherein the slings have a load capacity of in excess of 10,000 pounds (4,536 kg).
5. The bag apparatus of claim 1 wherein the slings are spaced apart laterally at a distance of between 6 and 24 inches (15 and 61 cm).
6. A bag for transporting bulk material, comprising:
 - a) a bag member that includes a bottom wall, side walls, bag corners, and a top wall;
 - b) a plurality of eyelets secured to upper parts of said sidewalls at the corners and next to the top portion;
 - c) an inlet tube secured to the top wall defining a material inlet;
 - d) a plurality of sling guides stitched to the bag member including bottom sling guides, side sling guides and corner sling guides;
 - e) each sling guide providing an open ended channel that is sized and shaped to receive a lifting sling and position the slings upon the bag member;
 - f) a pair of lifting slings that are attached to the sling guides, each lifting sling having loop end portions, each lifting sling removably secured to the bag member by passing through

a plurality of said guides, wherein each sling passes through one or more bottom sling guides, one or more side sling guides of two opposing side walls, and at least one corner sling guide;

g) wherein the lifting slings do not overlap; and

h) each sling being of a length that places the loops at an elevation near the top wall of the bag member.

7. A bag as claimed in claim 6, wherein the slings are spaced apart a distance of between about 6 and 24 inches (15 and 61 cm).

8. A bag as claimed in claim 6 wherein each sling occupies the channel of a pair of said corner sling guides.

9. A bag as claimed in claim 6 wherein each sling occupies the channel of a pair of said side sling guides.

10. A method of transporting bulk material from a beginning locale to a final locale, comprising the steps of:

a) providing a bag member that includes a bottom wall, side walls, bag corners, a top wall, a plurality of sling guides stitched to the bag including bottom sling guides, side sling guides and corner sling guides, each sling guide providing an open ended channel that is sized and shaped to receive a lifting sling;

b) rigging a pair of lifting slings to the bags by passing each lifting sling through a plurality of said sling guides, each sling having loop end portions, wherein the slings do not overlap;

c) filling the bag at the beginning locale with a volume of bulk material;

d) transporting the bag from the beginning locale to the final locale, wherein the bag is lifted with the lifting slings between steps "b" and "c", wherein the slings are rigged to the sling guides; and

e) cutting the bag with a cutting device that cuts the bottom wall at a position in between the slings.

11. The method of claim 10 wherein in step "d" the slings are maintained in generally spaced apart positions continuously along the lengths of the slings.

12. The method of claim 11 wherein in step "d" the slings are maintained in generally spaced apart positions parallel to one another.

13. A bulk bag apparatus, comprising:

- a) a bag having a bottom wall, a top portion, side walls and seams joining each side wall to another side wall, and bag corners at the seams;
 - b) a band that encircles the bag, the band being spaced above the bottom wall, the band continuously abutting the bag at the side walls;
 - c) first and second lifting slings rigged to the bag, the slings being spaced apart and not intersecting;
 - d) a portion of the bottom wall being exposed in between the slings;
 - e) bottom guides on the bag bottom;
 - f) corner guides that each extend from the bottom wall to a side wall;
 - g) each said guide providing an open ended channel that is receptive of a said first or second lifting sling.
14. The bag apparatus of claim 13 wherein the slings are removable from the guides.
 15. The bag apparatus of claim 13 wherein the top portion has an area, a top panel attached to the side walls and a fill opening in the top panel that is smaller than the said area.
 16. The bag apparatus of claim 13 wherein the slings have a load capacity of in excess of 10,000 pounds (4,536 kg).
 17. The bag apparatus of claim 13 wherein the slings are spaced apart laterally at a distance of between 6 and 24 inches (15 and 61 cm).
 18. A bag for transporting bulk material, comprising:
 - a) a bag member that includes a bottom wall, side walls, bag corners, and a top wall;
 - b) an inlet tube secured to the top wall defining a material inlet;
 - c) a plurality of sling guides stitched to the bag including guides that extend from the bottom panel to a said side wall;
 - d) each sling guide providing an open ended channel that is sized and shaped to receive a lifting sling;
 - e) a pair of lifting slings that are attached to the sling guides, each lifting sling having liftable end portions, each lifting sling removably secured to the bag member by passing through a plurality of said guides; and
 - f) each sling being of a length that places the sling end portions at an elevation near the top wall of the bag member.
 19. A bag as claimed in claim 18, wherein the slings are spaced apart laterally at a

distance of between 6 and 24 inches (15 and 61 cm).

20. A bag as claimed in claim 18 wherein each sling occupies the channel of a pair of said guides that are corner sling guides that are attached to both the bottom wall and a said side wall.

21. A method of transporting bulk material from a beginning locale to a final locale, comprising the steps of:

a) providing a bag member that includes a bottom wall, side walls, bag corners, a top wall, and a plurality of sling guides stitched to the bag;

b) rigging a pair of lifting slings to the bags by passing each lifting sling through a plurality of said sling guides and under the bag bottom wall, each sling having lifting end portions, and wherein the slings do not overlap;

c) filling the bag at the beginning locale with a volume of bulk material;

d) transporting the bag from the beginning locale to the final locale, wherein the bag is lifted with the lifting slings between steps "b" and "c", wherein the slings are rigged to the sling guides; and

e) cutting the bag with a cutting device that cuts the bottom wall at a position in between the slings.

22. The method of claim 21 wherein in step "d" the slings are maintained in generally spaced apart positions continuously along the lengths of the slings.

23. The method of claim 22 wherein in step "d" the slings are maintained in generally spaced apart positions parallel to one another.

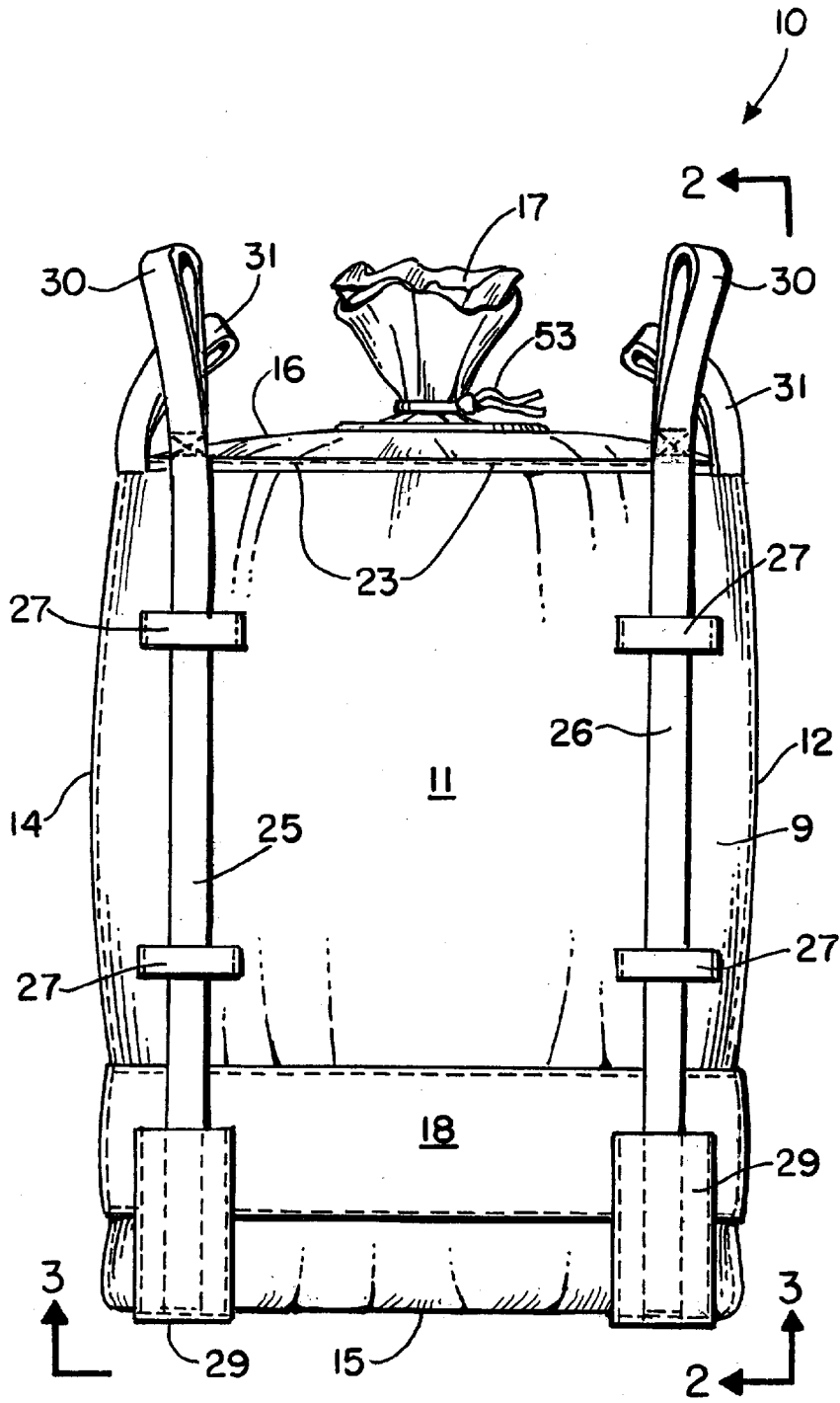

FIG. I.

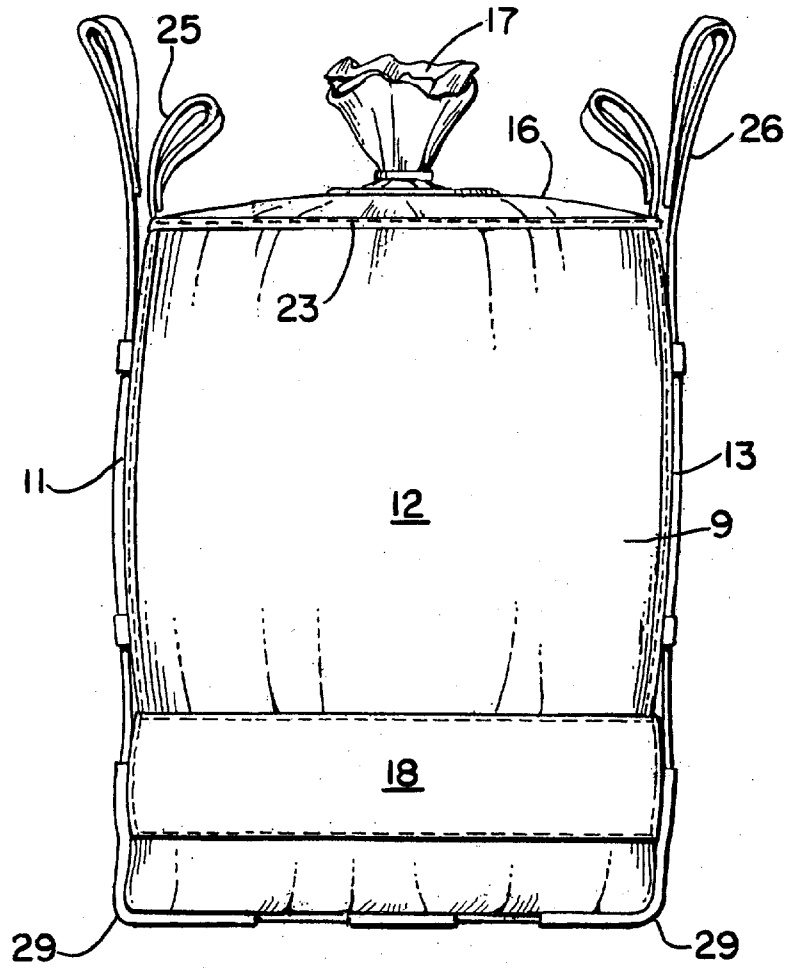

FIG. 2.

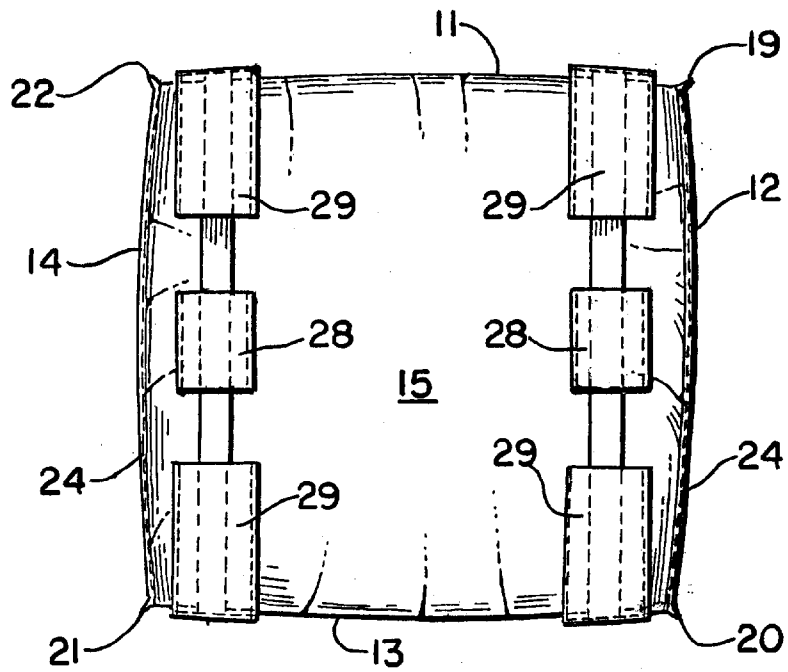

FIG. 3.

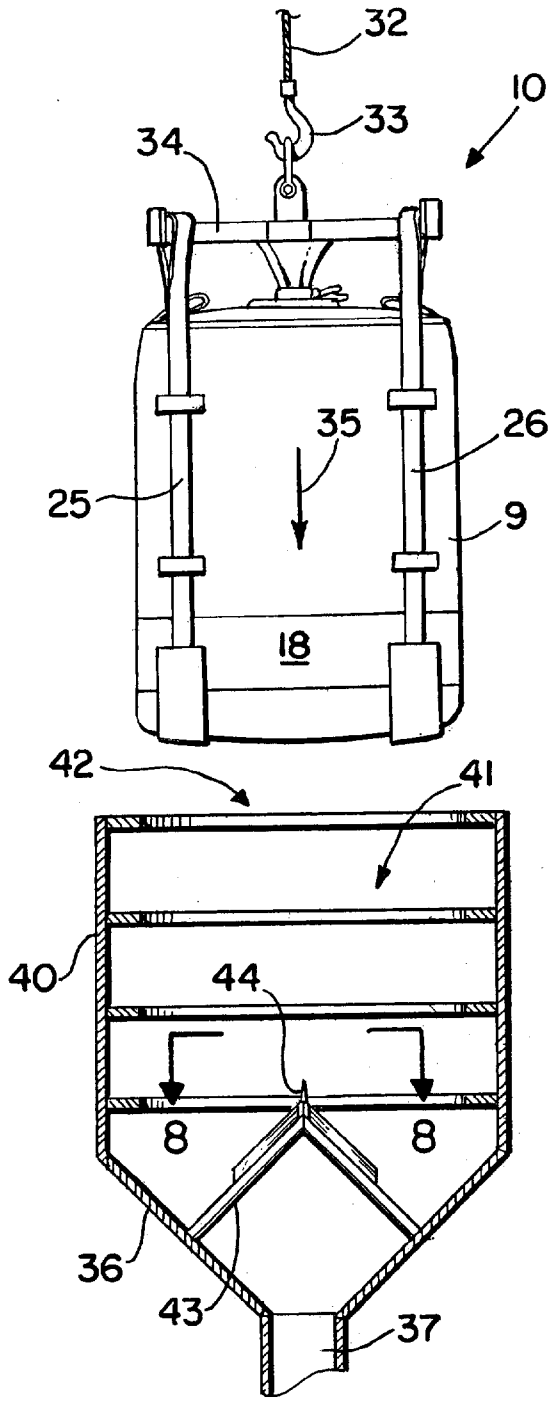

FIG. 4.

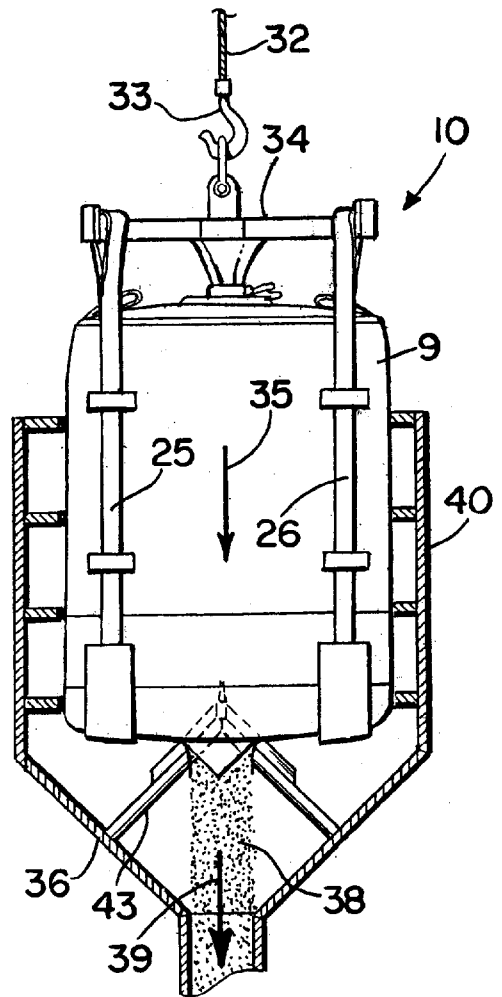

FIG. 5.

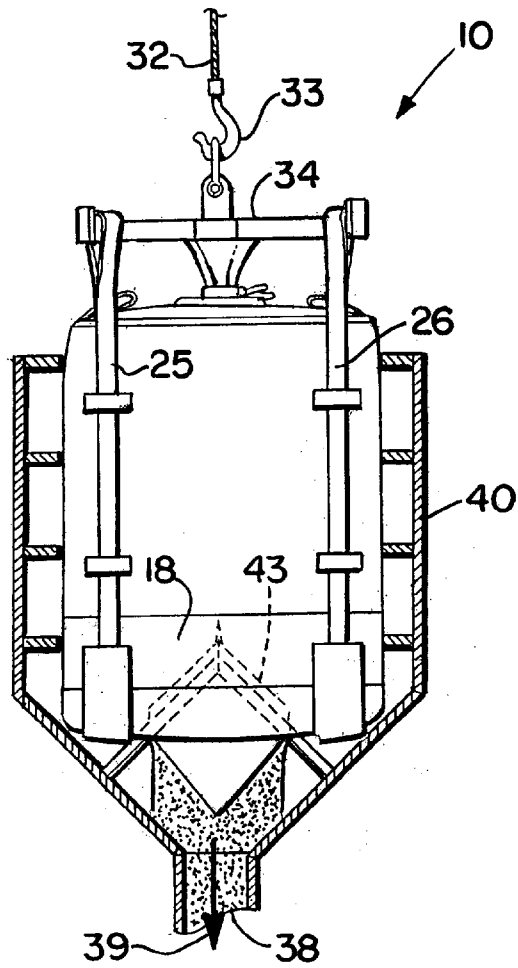

FIG. 6.

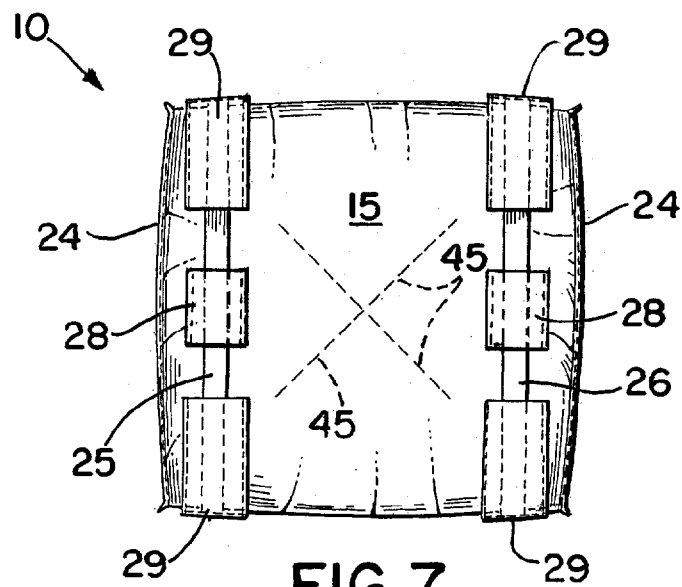

FIG. 7.

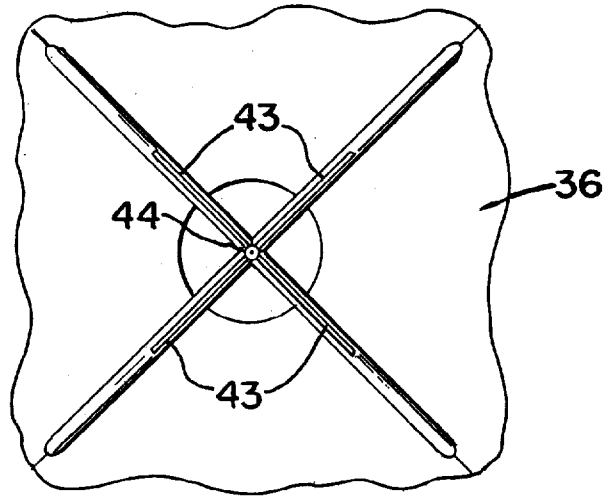

FIG. 8.

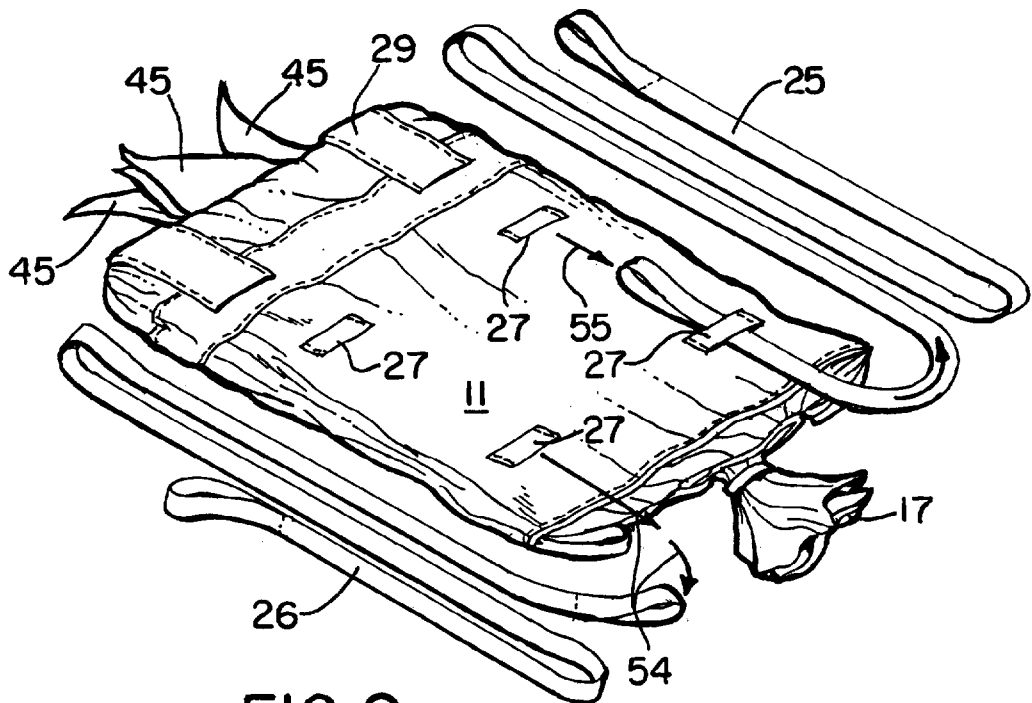

FIG. 9.

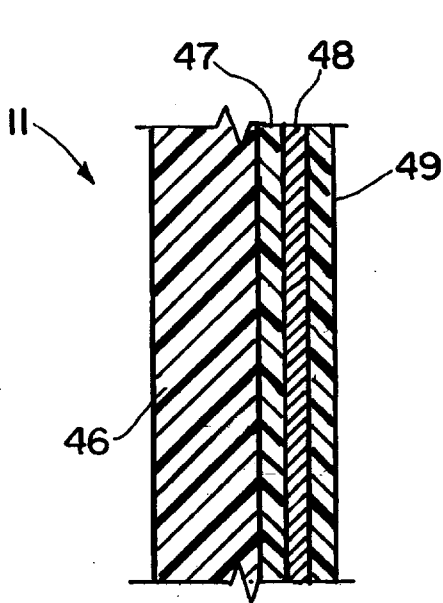

FIG. 10.

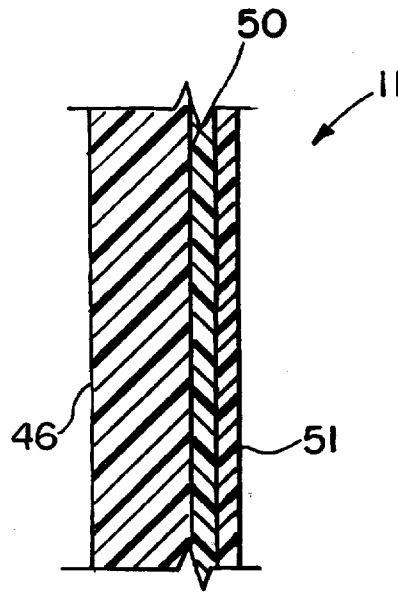

FIG. 11.

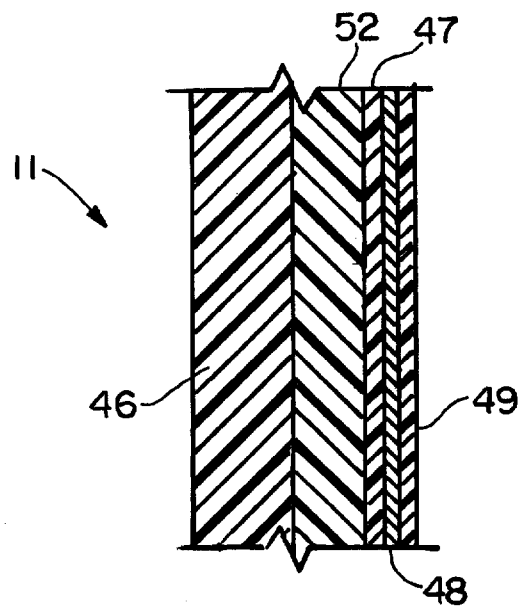

FIG. 12.

INTERNATIONAL SEARCH REPORT

International application No.

PCT/US 2013/046775

A. CLASSIFICATION OF SUBJECT MATTER		<i>B65D 88/16 (2006.01)</i> <i>B65D 33/14 (2006.01)</i> <i>B65D 33/00 (2006.01)</i>
According to International Patent Classification (IPC) or to both national classification and IPC		
B. FIELDS SEARCHED		
Minimum documentation searched (classification system followed by classification symbols)		
B65D 33/14, 88/12, 88/16, 33/00		
Documentation searched other than minimum documentation to the extent that such documents are included in the fields searched		
Electronic data base consulted during the international search (name of data base and, where practicable, search terms used)		
DWPI, Esp@cenet, RUPTO		
C. DOCUMENTS CONSIDERED TO BE RELEVANT		
Category*	Citation of document, with indication, where appropriate, of the relevant passages	Relevant to claim No.
Y	US 2010/0178126 A1 (DANIEL W. NESS) 15.07.2010, fig. 8	1-23
Y	CN 1796242 A (GAN G) 05.07.2006, fig. 11	1-23
A	US 7520707 B1 (DANIEL W. NESS) 21.04.2009	1-23
A	US 2002/0191869 A1 (GREGORY ROY STEWART et al.) 19.12.2002	1-23
<input type="checkbox"/> Further documents are listed in the continuation of Box C. <input type="checkbox"/> See patent family annex.		
* Special categories of cited documents:		
"A"	document defining the general state of the art which is not considered to be of particular relevance	"T" later document published after the international filing date or priority date and not in conflict with the application but cited to understand the principle or theory underlying the invention
"E"	earlier document but published on or after the international filing date	"X" document of particular relevance; the claimed invention cannot be considered novel or cannot be considered to involve an inventive step when the document is taken alone
"L"	document which may throw doubts on priority claim(s) or which is cited to establish the publication date of another citation or other special reason (as specified)	"Y" document of particular relevance; the claimed invention cannot be considered to involve an inventive step when the document is combined with one or more other such documents, such combination being obvious to a person skilled in the art
"O"	document referring to an oral disclosure, use, exhibition or other means	"&" document member of the same patent family
"P"	document published prior to the international filing date but later than the priority date claimed	
Date of the actual completion of the international search		Date of mailing of the international search report
04 October 2013 (04.10.2013)		24 October 2013 (24.10.2013)
Name and mailing address of the ISA/ FIPS Russia, 123995, Moscow, G-59, GSP-5, Berezhkovskaya nab., 30-1		Authorized officer V. Selivanov
Facsimile No. +7 (499) 243-33-37		Telephone No. (495)531-64-81