

(19) **DANMARK**

(10) **DK/EP 2025253 T3**



(12)

Oversættelse af
europæisk patentskrift

Patent- og
Varemærkestyrelsen

-
- (51) Int.Cl.: **A 41 D 19/015 (2006.01)** **A 41 F 1/06 (2006.01)**
- (45) Oversættelsen bekendtgjort den: **2018-01-02**
- (80) Dato for Den Europæiske Patentmyndigheds bekendtgørelse om meddelelse af patentet: **2017-09-27**
- (86) Europæisk ansøgning nr.: **08013920.7**
- (86) Europæisk indleveringsdag: **2008-08-02**
- (87) Den europæiske ansøgnings publiceringsdag: **2009-02-18**
- (30) Prioritet: **2007-08-13 DE 102007038224**
- (84) Designerede stater: **AT BE BG CH CY CZ DE DK EE ES FI FR GB GR HR HU IE IS IT LI LT LU LV MC MT NL NO PL PT RO SE SI SK TR**
- (73) Patenthaver: **Ziegler Arbeitsschutz GmbH, In den Waldäckern 41, 75417 Mühlacker, Tyskland**
- (72) Opfinder: **ZIEGLER, Jürgen, Marie-Elisabeth-Lüders-Weg 6, 75428 Illingen, Tyskland**
- (74) Fuldmægtig i Danmark: **Patrade A/S, Fredens Torv 3A, 8000 Århus C, Danmark**
- (54) Benævnelse: **Beskyttelsesbeklædning med fastgørelsesmiddel**
- (56) Fremdragne publikationer:
DE-C- 192 929
DE-U1- 9 313 344
FR-A1- 2 825 589

Field of the Invention

5 The invention relates to a protective clothing item with a fastening means for fastening the protective clothing on the body of the user, according to the preamble of claim 1.

Prior Art

10 A protective clothing item of this type made of metal ring mesh is known from DE 93 13 344 U1 and is worn, for example, by butchers to protect them against impact, stabbing and cutting injuries. Such metal ring meshes are highly flexible and maintain the mobility of the hand that they are intended to protect. The fastening of the protective glove takes place by means of a fastening strap introduced into
15 receptacles formed by the metal ring mesh with a fixing device which is releasably fixed with its one part at a hole of the metal ring mesh. The other part of the fixing device is displaceably fastened on the other end of the fastening strap and is fixed on the first part. The first part of the fixing device is releasably fastened on the fastening strap in order to enable an eversion of the glove.

20 A protective clothing item that is made at least partially of metal ring mesh is known from WO 2006/011416 A1. In order to fasten the protective clothing item on the body of the user, fastening means in the form of straps are provided, which are connected or chained to the protective glove. A preferred fastening form is a button device wherein the press button is fastened to a location on the
25 glove and, on the strap-like fastening means, the press button receptacle is fastenable longitudinally displaceable in order to allow adaptation to different sizes. For this purpose, the press button receptacle is fastened to a clamping element which comes into engagement with ribs of the plastics strap in order thereby to enable a reliable fixing, but if necessary also an easier opening of the fastening means.
30

From FR 2 729 274 A1 and the comparable US 2004/0181848 A1, there are known protective gloves in which a part of a press button for fastening a closing strap is firmly arranged in an accommodation channel for the closing strap. The
35 other part of the press button device is fastened on the closing strap. The actual fixing takes place by means of a buckle which is movably displaceable along the closing strap and which cooperates with a further press button device fixed on the accommodation channel but not on the fastening means. Therefore a fastening

takes place at the strap outlet from the accommodation channel and at the strap end by means of parts not removable from the glove.

5 From US-A 5,054,126, there is known a protective glove with two conventional press buttons on a textile closing strap for closing. Provided on the periphery of the closing strap are a press button for a first press button receptacle and, spaced therefrom, a press button receptacle for a second press button. The counterpart is formed by an adjustable element which is adjustable along the closing strap and which forms, on one side, the first press button receptacle and, on the other side,
10 the second press button. If the glove is everted for use on the other hand, therefore, firstly this element is to be adapted to the changed position of the counterpart, which makes handling of the glove difficult. The textile closing strap causes disadvantages for sterilisation and therefore does not meet the conditions to be fulfilled for the necessary hygiene. It is also subject to a significantly greater wear
15 than the rest of the protective glove.

From DE 20 2005 011 181 U1, there is known a protective glove made of a metal ring mesh, in which the closing strap has at its linear end a stop part different from the clasp, which enters into positive locking with the edge of a loop and cannot be pulled through the loop.
20

Interchangeable press button closures per se have been known in the textiles field for more than 100 years from DE 192 929 C. However, they have clearly not influenced the development in the field of protective gloves made of metal ring mesh, as the further cited prior art makes clear.
25

Field of the invention

Proceeding from this prior art, it is an object of the present invention to provide a durable protective clothing item with a fastening device.
30

This object is solved with a protective clothing item having the features of claim 1.

35 On the fastening means, for fastening the protective clothing item on the body of the user, the protective clothing item has a fixing device, a first part of which is buttoned through a button hole preferably provided in the metal ring mesh, so that the fastening means is fixed in its longitudinal direction on the protective

glove. If the fastening means is not metallic, by reason of the simple fastening, it can be easily removed and subjected to cleaning suited to the material. The glove itself can be sterilized without difficulty so that hygiene requirements can be complied with, particularly in the food industry. In addition, the glove can be used on either side since, when required, the closing strap must merely be buttoned in in the relevant direction.

Preferably, the fixing device is a button device consisting of a button, preferably a press button and an associated receptacle wherein the button is fixed with its lower part in the region of the button hole. The further part of the fixing device is arranged longitudinally displaceable at the end of the fastening means. The button receptacle arranged there cooperates with the button, although it is not critical which part is arranged at which end. Optionally, the possibility also exists of forming the strap in multiple parts and of fixing the button in a suitable manner on the metal ring mesh in order then to fasten the fastening means there.

Further advantages are disclosed in the further dependent claims and the following description.

Brief Description of the Figures

The invention will now be described making reference to the exemplary embodiments illustrated in the drawings. In the drawings:

Figs. 1, 2 show a part of a protective clothing item in the form of a protective glove on the arm of a user in a view of the hand and arm from above and from below,

Fig. 3 shows an enlarged side view of the part of a fixing device configured to be buttoned in,

Fig. 4 shows a plan view of such a part according to Fig. 3 which is fixed on the fastening means,

Fig. 5 shows a side view of the fixing device according to Fig. 3 in the state buttoned into the metal ring mesh,

Fig. 6 shows a representation according to Fig. 5 with a complete fixing device.

35

Detailed description of preferred embodiments

Before the invention is described in detail, it should be noted that it is not re-

stricted to the respective components of the device and the respective method steps, since these components and methods can vary. The expressions used here are intended merely to describe particular embodiments and are not used restrictively. If, furthermore, the singular or the indefinite article is used in the description or in the claims, this also relates to a plurality of these elements, provided
5 the overall context does not clearly reveal otherwise.

Figs. 1 and 2 shows a protective glove as a protective clothing item which is used here, by way of example, for the fastening of a clothing item on a user by means
10 of a fastening means. The fastening type, that is, the use of a fastening means that is buttoned into a protective clothing item which consists at least partially of metal ring mesh is however essentially possible for a protective clothing item which is also applied to other parts of the body, for example, to the legs or the body itself. A protective clothing item of this type serves to protect, for example,
15 butchers against stabbing, impact and cutting injuries. The protective clothing item is fixed with fastening means 10 to the body of the user. A protective glove also usually has a cuff 22 which is stiffened by stiffening means 23. The protective clothing item consists at least partially of a metal ring mesh, although it can also comprise other materials.

20 The at least one strap-like fastening means 10 is accommodated at least partially in an accommodation channel 11 according to Figs. 5, 6, which can also be formed by loops, and thus does not have to be formed as continuous. The fastening means is connected to the metal ring mesh. Provided on the fastening
25 means 10 is a fixing device 12 which, in the exemplary embodiment, is itself configured as a button device with a button 13 and a receptacle 14 which is connectable thereto if required and receives the button. However, other fixing devices are possible, provided, as will be shown below, at least one of its parts is fixed in a button hole 15 of the protective clothing item. Typically, the fixing device is a
30 press button device, as is known from the prior art, of which a first part is buttoned into the button hole 15.

The walls of the accommodation channel 11 and/or the loops preferably consist of metal ring mesh 20. The wall of the accommodation channel 11 or the loops have
35 the button hole 15 through which a first part of the fixing device 12, specifically the button 13 or the receptacle 14 is releasably buttoned. The associated further part of the fixing device 12 as the corresponding counterpart, specifically the receptacle 14 or the button 13 is fastenable to this first part.

The fixing device 12 which is shown fully assembled in Fig. 6 has, on the part connected to the button hole 15, a base plate 16 as in Fig. 3, which is introduced into the loop or into the accommodation channel 11, and a constriction 17 which, as in Figs. 5, 6, is buttoned into the button hole 15 such that the metal ring mesh 20 adjoins the constriction 17. Preferably, the slit of the button hole 15 extends transversely to the longitudinal direction of the strap-like fastening means 10, that is, in the representation of Fig. 4, from top to bottom. This permits the fixing of the fastening means in the longitudinal direction, wherein the fastening means can itself also end, as shown in Fig. 5 at right, behind the buttoning in. The first part of the fixing device, in Fig. 3 the button 13, is arranged above the constriction 17, which itself is buttoned through the button hole 15 when the strap-like fastening means is fastened on the metal ring mesh or on the protective glove. In principle, the button hole 15 does not have to be provided in the region of the metal ring mesh if correspondingly suitable materials are selected which enable a fixing of the fastening means in the fastening direction.

The first part of the button device 12 is firmly connected to the fastening means 10. This is made clear by the fastenings 19 in Figs. 4 to 6. At the same time, this first part is connectable with positive engagement to the button hole 15 and is simultaneously mounted on the fastening means 10, so that the fastening means cannot be pulled out in the fastening direction.

In order to fasten the glove on the hand of the user or on the protective clothing item on the body of the user, in the exemplary embodiment, the fastening means 10 is guided round the hand of the user, wherein the other end of the fastening means 10 is then releasably fastened to the further part, in Fig. 6 at the top on the fixing device 12. The further part of the fastening device is preferably longitudinally displaceably fixable there, which in the exemplary embodiment takes place by means of a clamping element 30 which is connected as a further part to the receptacle 14 and on which the fastening means 10 is longitudinally displaceable. This can take place, as is known from the prior art, by means of a strap correspondingly provided with ribs, which engages in the clamping element 30.

Preferably, the first part and the further part of the fixing device 12 are fixed or fixable on a single-piece strap configured as a fastening means. If required, however, one part of the fastening device can also be buttoned into the protective clothing item and the other part fastened thereon, although it is merely connected

to the protective clothing item at one other location, that is, in this case no continuous strap is connected, to which both the parts of the fastening device are fixed.

5 In the region of the loops and/or of the accommodation channel 11 and also in the region of the button hole 15, the metal ring mesh is penetrated by corresponding passage openings A, B. These passage openings serve to guide the fastening means 10, for example a closing strap, through on the outside of the protective glove in order to fix it there with known fixing means such as the fixing
10 device 12. In Figs. 7 and 8, such fixings are not shown, since they are known to persons skilled in the art. It is also self-evident that the closing strap shown in Fig. 7 is fixed at its end in the accommodation channel 11 or at a suitable other site of the accommodation channel, for example, at the button hole 15, in order to prevent withdrawal.

15 The opening for passing through the closing strap on the outer side of the protective glove and/or the button hole 15 are formed, in the exemplary embodiment, by a plurality of passage openings A, B spaced from one another in the peripheral direction of the protective glove, of which at least one is provided on the outer
20 side and at least one on the inner side on the protective glove. This means that, for example, also on eversion of the protective glove, the respective button hole can be displaced relative to the button hole responsible for the other side of the glove. The passage openings A, B are provided in the region of the accommodation channel 11 or in the region of loops. The fastening means 10 can thus alter-
25 nately be fed outwardly through the openings or buttoned there whilst, at the same time, it is ensured that the bottom of the respective opening is still covered by metal ring mesh. By this means, it is almost impossible to reach through the slits with a knife or keyhole saw to the body of the wearer.

30 According to Fig. 7, the accommodation channel 11 is formed of metal ring mesh in which the passage openings A, B are provided as slits. These slits are situated alternately, seen from a midline of the hand of a wearer, radially internally and radially externally. By this means it is possible that, in the representation of Fig. 7, the fastening means 10 can pass outwardly through the opening A. If the glove
35 is everted, the fastening means 10 can emerge outwardly through the opening B so that the fastening means 10 must only be withdrawn and passed through on the corresponding other side.

The two passage openings A, B in the exemplary embodiment are offset to one another in the peripheral direction and at a spacing X according to Fig. 8. It is herein clear, particularly from Fig. 7, that the bottom of the passage openings A, B is covered by the opposite side of the accommodation channel 11 or the loop. In order to clarify this, in Fig. 8, the ring structure is not drawn in the region of the accommodation channel 11. Thus it is made clear that the passage opening A which is accessible from outside in Fig. 7 is covered on the rear side by the rear wall 11a of the accommodation channel 11, whereas the passage opening B situated behind in Fig. 8 is covered by the front wall 11b of the accommodation channel 11. The passage openings A, B can also be the button holes 15.

Reference signs

	10	Fastening means
	11	Accommodation channel
5	11a	Rear wall
	11b	Front wall
	12	Fixing device
	13	Button
	14	Receptacle
10	15	Button hole
	16	Base plate
	17	Constriction
	19	Fastening
	20	Metal ring mesh
15	22	Cuff
	23	Stiffening
	30	Clamping element
	A, B	Passage openings

Patentkrav

1. Beskyttelsesbeklædning, som i det mindste delvist består af et metalringvæv med mindst et stroplignende fastgørelsesmiddel (10), der optages i det mindste delvist i en optagelseskanal (11) eller i sløjfer og forbundet med metalringvævet (20) til fastgørelse af beskyttelsesbeklædningen på brugerens krop, hvori en fikseringsindretning til fiksering af fastgørelsesmidlet er tilknyttet det stroplignende fastgørelsesmiddel, hvori optagelseskanalen (11) har et hul, ved hjælp af hvilket en første del af fikseringsindretningen (12) er løsbart fastgjort, og mindst en gennemgangsåbning (A, B) til gennemføring af fastgørelsesmidlet (10) ud fra optagelseskanalen (11), og hvori den tilknyttede yderligere del af fikseringsindretningen (12) kan fastgøres på den første del, **kendetegnet ved, at** optagelseskanalen (11) har et knaphul (15), gennem hvilket den med fastgørelsesmidlet (10) fast forbundne første del af fikseringsindretningen (12) er løsbart knappet, og at knaphullet (15) og den mindst ene gennemgangsåbning er dannet af flere gennemgangsåbninger (A, B) placeret i indbyrdes afstand i beskyttelsehandskens omkredsretning.
2. Beskyttelsesbeklædning ifølge krav 1, **kendetegnet ved, at** fikseringsindretningen er en knapindretning med en knap (13) og et optag (14), som efter behov kan forbindes dertil som dele af fikseringsindretningen.
3. Beskyttelsesbeklædning ifølge krav 1 eller 2, **kendetegnet ved, at** knaphullet er tilvejebragt med sin længdeudstrækning på tværs af fastgørelsesmidlets (10) stropforløb i optagelseskanalen (11) eller sløjfen.
4. Beskyttelsesbeklædning ifølge et af de foregående krav, **kendetegnet ved, at** den første del kan forbindes formluttende med knaphullet (15).
5. Beskyttelsesbeklædning ifølge et af de foregående krav, **kendetegnet ved, at** den anden del kan fikseres længdeforskydeligt på fastgørelsesmidlet (10).
6. Beskyttelsesbeklædning ifølge et af de foregående krav, **kendetegnet ved, at** den anden del er monteret på et klemelement (30), som er længdeforskydeligt langs fastgørelsesmidlet (10) og kan fikseres efter behov.

7. Beskyttelsesbeklædning ifølge et af de foregående krav, **kendetegnet ved, at** den første del og den anden del er fastgjort eller kan fastgøres på en strop i ét stykke udformet som et fastgørelsesmiddel.
- 5 8. Beskyttelsesbeklædning ifølge et af de foregående krav, **kendetegnet ved, at** den metalringvævet er vendbar og at mindst en af gennemgangsåbningerne (A, B) er tilvejebragt udvendigt og mindst en er tilvejebragt indvendigt på beskyttelseshandsken.
- 10 9. Beskyttelseshandske ifølge krav 8, **kendetegnet ved, at** optagelseskanalen (10) er lavet af metalringvæv og at gennemgangsåbningerne (A, B) er tilvejebragt som slidser på optagelseskanalen set fra midterlinien af en bærers hånd radielt indvendigt og radielt udvendigt.
- 15 10. Beskyttelseshandske ifølge krav 8 eller 9, **kendetegnet ved, at** to gennemgangsåbninger (A, B) er indbyrdes forsat i omkredsretningen med afstanden X.
- 20 11. Beskyttelseshandske ifølge et af kravene 8 til 10, **kendetegnet ved, at** bunden af gennemgangsåbningerne (A, B) er dækket af den modsatte side af optagelseskanalen eller sløjfen.

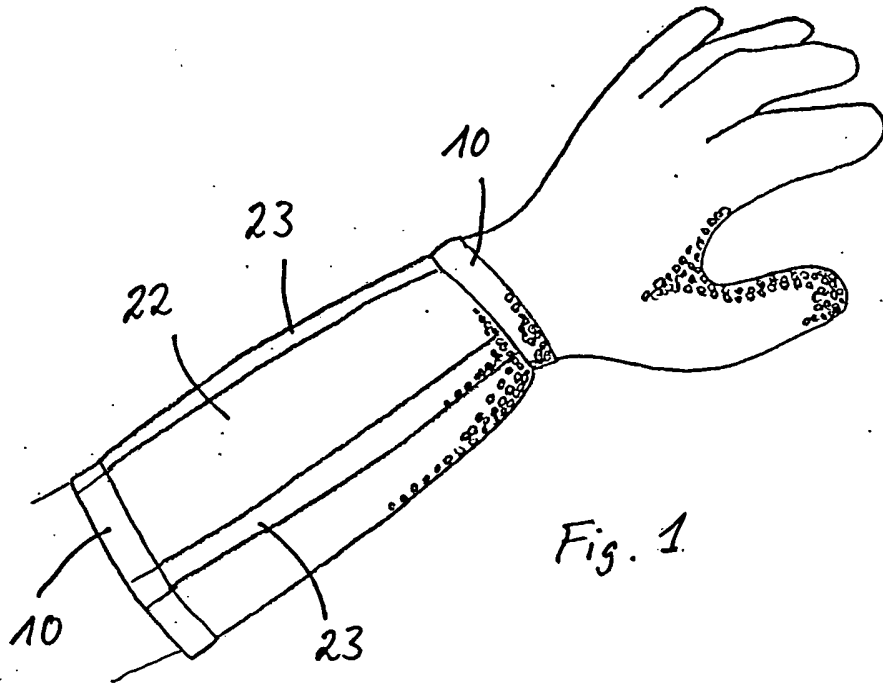

Fig. 1

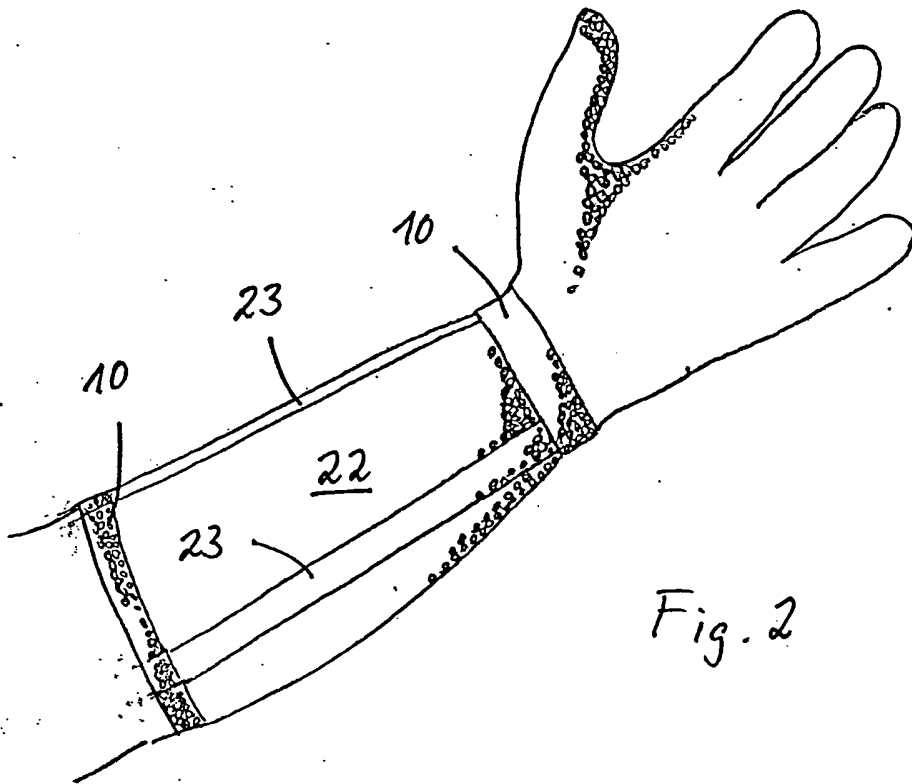

Fig. 2

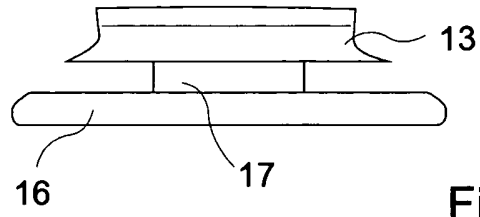

Fig. 3

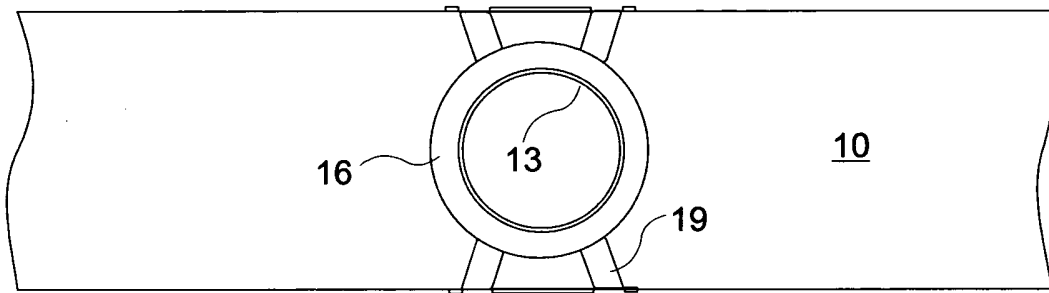

Fig. 4

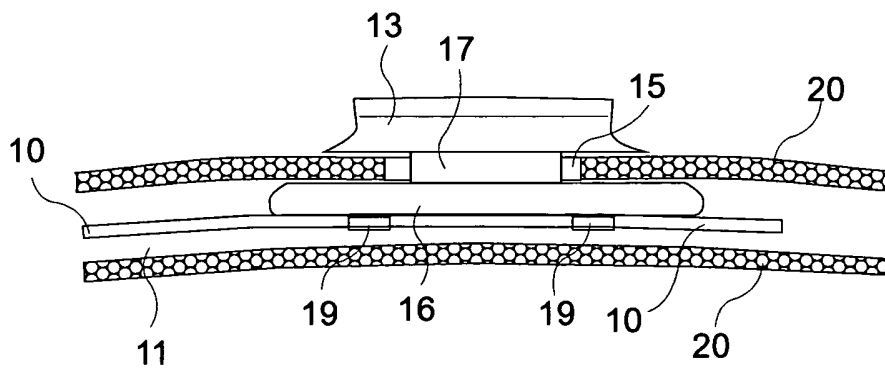

Fig. 5

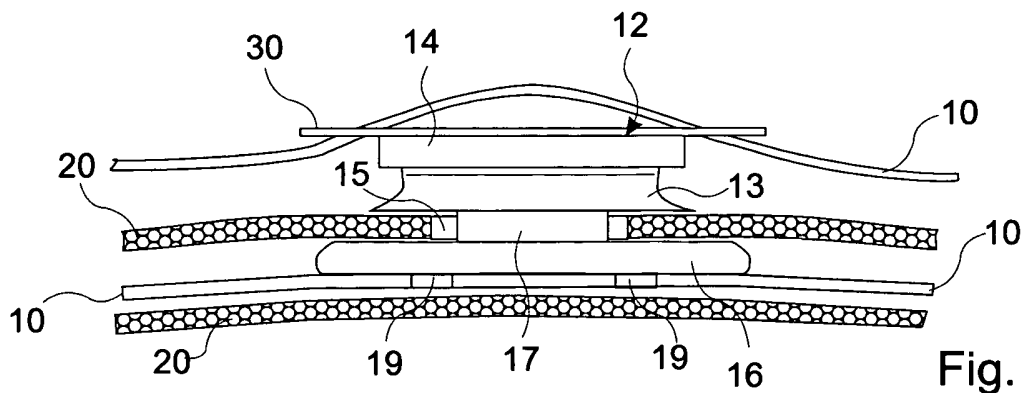

Fig. 6

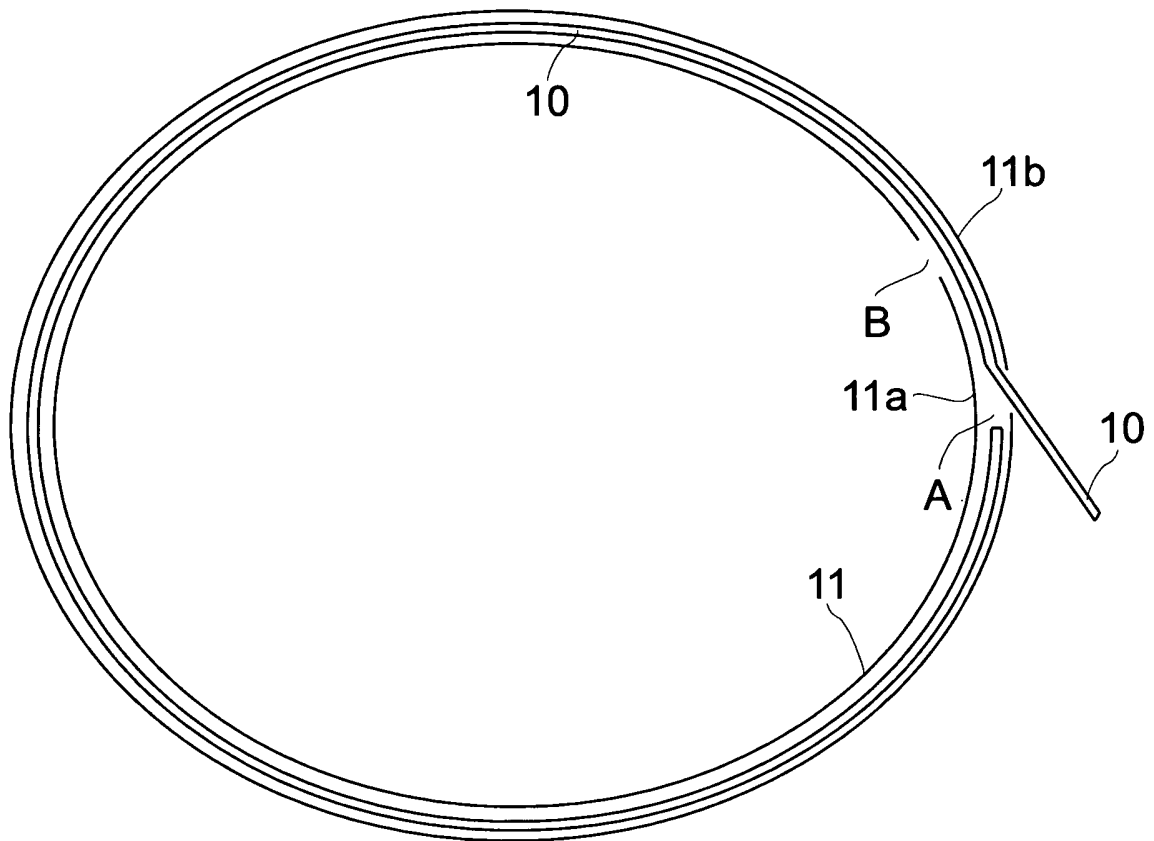

Fig. 7

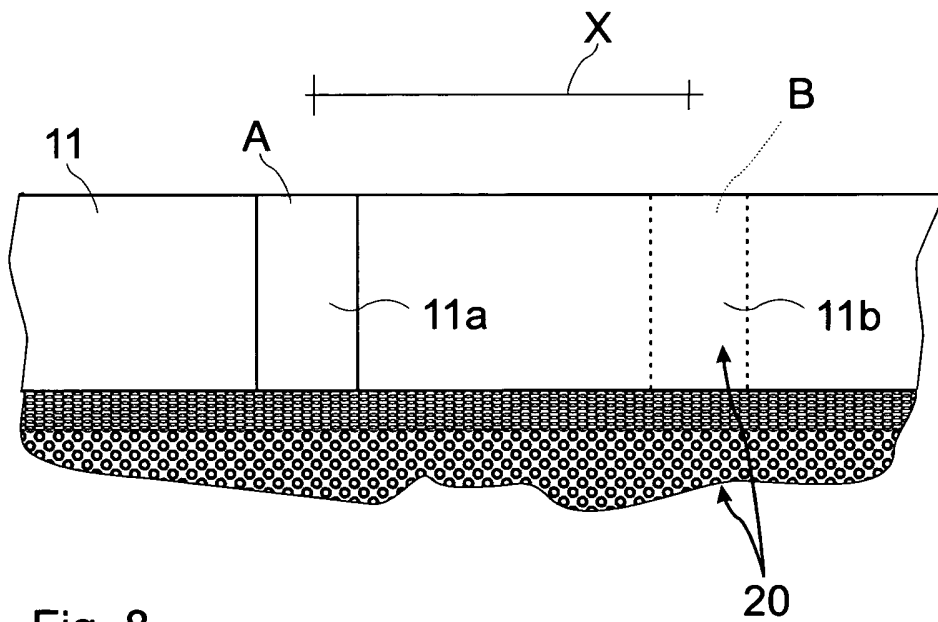

Fig. 8