

(19) World Intellectual Property
Organization
International Bureau



(43) International Publication Date
17 March 2005 (17.03.2005)

PCT

(10) International Publication Number
WO 2005/023672 A1

(51) International Patent Classification⁷: **B65D 75/34**,
75/22, 73/00, A61J 7/04

Netherton, Huddersfield HD4 7DJ (GB). **PENDLE, Bernard** [GB/GB]; 38B Church Lane, Wingfield, Trowbridge, Wiltshire BA14 9LW (GB).

(21) International Application Number:
PCT/GB2004/003739

(74) Agent: **BAILEY WALSH & CO LLP**; 5 York Place, Leeds LS1 2SD (GB).

(22) International Filing Date:
2 September 2004 (02.09.2004)

(81) Designated States (unless otherwise indicated, for every kind of national protection available): AE, AG, AL, AM, AT, AU, AZ, BA, BB, BG, BR, BW, BY, BZ, CA, CH, CN, CO, CR, CU, CZ, DE, DK, DM, DZ, EC, EE, EG, ES, FI, GB, GD, GE, GH, GM, HR, HU, ID, IL, IN, IS, JP, KE, KG, KP, KR, KZ, LC, LK, LR, LS, LT, LU, LV, MA, MD, MG, MK, MN, MW, MX, MZ, NA, NI, NO, NZ, OM, PG, PH, PL, PT, RO, RU, SC, SD, SE, SG, SK, SL, SY, TJ, TM, TN, TR, TT, TZ, UA, UG, US, UZ, VC, VN, YU, ZA, ZM, ZW.

(25) Filing Language: English

(26) Publication Language: English

(30) Priority Data:
0320533.3 2 September 2003 (02.09.2003) GB

(71) Applicant (for all designated States except US): **MEDISEAL LTD** [GB/GB]; 38B Church Lane, Wingfield, Trowbridge, Wiltshire BS14 9LW (GB).

(84) Designated States (unless otherwise indicated, for every kind of regional protection available): ARIPO (BW, GH, GM, KE, LS, MW, MZ, NA, SD, SL, SZ, TZ, UG, ZM, ZW), Eurasian (AM, AZ, BY, KG, KZ, MD, RU, TJ, TM), European (AT, BE, BG, CH, CY, CZ, DE, DK, EE, ES, FI, FR, GB, GR, HU, IE, IT, LU, MC, NL, PL, PT, RO, SE, SI,

(72) Inventors; and
(75) Inventors/Applicants (for US only): **WALMSLEY, David** [GB/GB]; Unit B1, Crosland Industrial Estate,

[Continued on next page]

(54) Title: DISPENSING APPARATUS

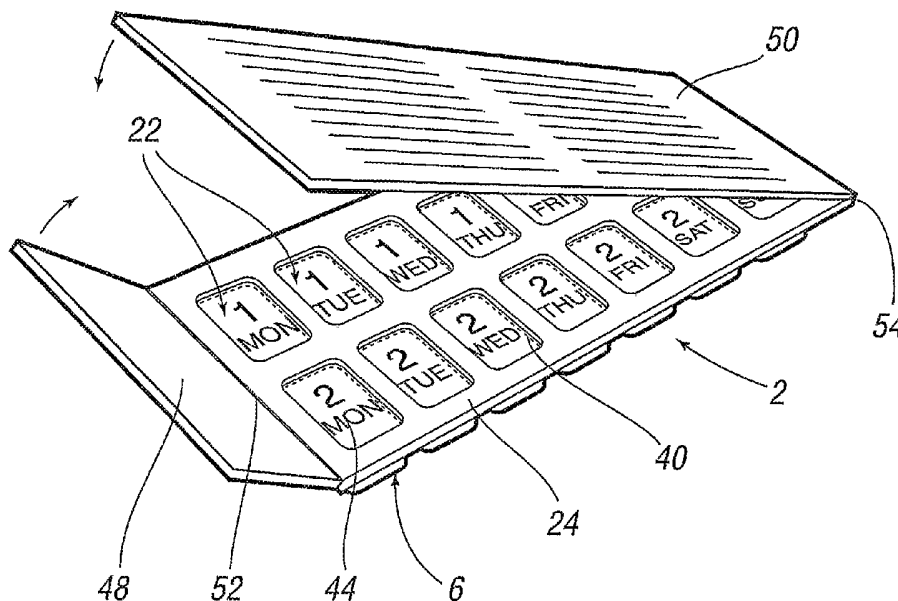

(57) Abstract: The invention relates to a dispensing apparatus, typically in the form of a pack containing medication held in compartments provided in the pack, said medication having been selectively placed therein by an authorised person, typically in relation to a prescription for a particular patient. The compartments, with the medication therein, are sealed by a sealing layer and a retention means is attached to the body of the apparatus to retain the sealing means in position. Access is gained to the medication by breaking through the sealing means at a location of the required compartment in which the medication to be consumed is located.

WO 2005/023672 A1



SK, TR), OAPI (BF, BJ, CF, CG, CI, CM, GA, GN, GQ,
GW, ML, MR, NE, SN, TD, TG).

For two-letter codes and other abbreviations, refer to the "Guidance Notes on Codes and Abbreviations" appearing at the beginning of each regular issue of the PCT Gazette.

Published:

— *with international search report*

Dispensing Apparatus

This invention relates to dispensing apparatus, and particularly but not necessarily exclusively to dispensing apparatus for containing and dispensing pre-determined quantities of medication therefrom

Dispensing apparatus which allows a pre-defined dose of a particular medication to be accessed by a user independently of other medication doses contained in the apparatus are known. This type of apparatus allows a user to easily take their medication without over or under dosing and, since the apparatus typically has a date, day or time associated with each dose, the user can clearly identify whether they have taken their medication for a particular time period, or not.

Dispensing apparatus typically falls into two categories; disposable dispensing apparatus and non-disposable dispensing apparatus. An example of a known disposable dispensing apparatus, such as the type used for the containment of medication such as aspirin, includes a plastic tray provided with a plurality of compartments, with a single tablet located in each compartment. A metal foil is heat sealed or adhered to an upper surface of the tray to cover the openings of the compartments. When a user requires access to a compartment to extract a pill therefrom, they simply depress the base of the compartment and push the pill through the foil. This apparatus allows a user to independently access each compartment but the apparatus is normally pre-formed by a manufacturer and packaged in a box. As the metal foil seals the compartments, the dosage of medication in the compartments cannot subsequently be altered by a pharmacist or doctor. As such, this type of apparatus cannot be used to provide different users with different types of

medication or different dosages of medication and is therefore of only limited use.

Dispensing apparatus which allows the dosage of medication contained therein to be selected by an administrator, such as a pharmacist or doctor in response to a prescription for a particular patient is known but such apparatus is generally non-disposable. An example of dispensing apparatus of this type includes a substantially rigid box divided into a plurality of compartments arranged in a series of rows and columns. Each row and/or column is provided with closure means which are operable to allow access to be gained to each compartment. However, the lid tends to be opened such that all the compartments can be accessed at any one time, thereby allowing a user to easily over dose on medication. In addition, such apparatus is generally expensive to manufacture.

It is therefore an aim of the present invention to provide dispensing apparatus which is inexpensive to manufacturer and which allows a user to access a particular dose of medication independently of at least one other medication dose contained therein.

It is a further aim of the present invention to provide dispensing apparatus which does not require an administrator, such as a pharmacist or doctor, to use adhesive, a heat sealing method and/or the like to seal the medication compartments therein.

According to a first aspect of the present invention there is provided dispensing apparatus for items of medication, said apparatus including a container portion having one or more compartments formed therein for the containment of said medication, sealing means for location over said compartments and wherein the sealing means is held in position with respect to

said compartments by a retaining portion, said compartment portion and/or retaining portion having engagement means which cooperate to retain the sealing means in position.

Typically the apparatus can be used by the person whom is to consume the medication thereby allowing the person to self dispense the medication from the apparatus as and when it is required to be consumed and/or by a carer, such as a nurse who can dispense the medication to the patient to consume the medication. The medication is typically initially selectively placed into the apparatus by an administrator or pharmacist authorised to do so, typically in accordance with a prescription for a particular person who is to consume the medication.

Preferably the sealing means is in the form of a sheet like material or film, such as a metallic foil, board material, plastic sheet and/or the like. The sealing means is typically not provided with any adhesive thereon and is held in place by mutual engagement of the retaining portion and container portion engagement means.

In one embodiment at least part of the sealing means is substantially transparent to allow a user to view the medication contained therein.

Preferably the sealing means is provided with perforation or frangible means thereon to allow a user to access a compartment by breaking and/or removing a portion of the sealing means. In one embodiment each of the perforation or frangible means when broken allows access to one of the compartments and are preferably substantially aligned with the openings of the compartments. Thus, access to one compartment can be gained independently of access to any other compartment.

Alternatively the sealing means can be formed from or have portions of material which can be easily broken/torn, such as paper or plastic.

Preferably the retaining portion is provided with a plurality of apertures therein and said apertures are substantially aligned with the openings of the compartments and preferably also the perforation or frangible means in the sealing means so as to allow access straight through the retaining portion and sealing means when the perforations are broken to the selected medication dose in a particular compartment.

In one embodiment the retaining portion comprises a flat or sheet like material with apertures provided therein.

In one embodiment the retaining portion is detachably attached to the container portion. Alternatively, the retaining portion can be integrally formed or pivotally attached to the container portion. For example, the retaining portion can be hinged to the container portion if required.

Preferably the engagement means of the retaining portion and/or container portion include any or any combination of one or more clips, straps, protrusions/apertures, channels/flanges and/or the like.

In a preferred embodiment the engagement means of one of the retaining portion or container portion is in the form of one or more protrusions which engages with one or more complementary recesses or apertures on the other of said retaining portion or container portion.

Preferably engagement means are provided adjacent each compartment or opening on the container portion and/or retaining portion.

In one embodiment, engagement of the retaining portion with the container portion is irreversible when assembled, thereby providing a tamper evident container.

In one embodiment the container portion is in the form of a tray.

In one embodiment the apparatus is disposable such that when all of the medication has been removed the apparatus is discarded. Alternatively the invention may be re-used with a new sealing means inserted in position.

Information matter can be provided on any of the sealing means, retaining portion and/or container portion. This allows a user to be informed of the date, time, dose or type of medication and/or the like.

In a further embodiment a records card can be offered to the apparatus, said card allowing details relating to the medication in the dispensing apparatus to be attached to or entered therein. Typically the records card is attached by locating the same between the container portion and retainer portion and engagement with the engagement means.

In one embodiment the sealing means can include a body portion with one or more panels joined thereto. The panels can be of any size and typically can be folded to lie over at least a part of the apparatus when assembled. This provides additional protection to prevent accidental puncturing of the sealing means.

In one embodiment, the apparatus is provided to be modular to allow a dispensing apparatus pack of a required size to be formed by joining together respective container portions side to side via matching location means. Thus the apparatus can be adapted to suit the amount of medication which is required to be dispensed to patient by joining the portions together to provide an increased number of medication containing compartments to suit the required number of medication doses which are required to be provided within the dispensing apparatus. In one embodiment, this fixing of the dispensing apparatus together can be achieved by bringing together matching location means provided on the edges of the respective dispensing apparatus and may be overlaid by sealing means and a retainer portion for each of the container portions or alternatively by providing a single common sealing means and/or retainer portion which overlies all of the compartments of the joined container portions.

In accordance with the invention, by the provision of the container portion, retaining portion and the sealing means in the form as herein described, so the medication can be inserted into the compartment of the container portion in the order of use. Thus, the first medication can be inserted into the first medication dosage compartment to be taken and thereafter the compartments filled in order of required dosage consumption. This is in contrast to many conventional systems wherein the medication is required to be inserted into compartments in reverse dosage order and is especially the case where the sealing means has to be adhered to the compartments.

In a further embodiment, the engagement means between the retaining portion and the compartment portion is provided to have two fixing conditions. A first fixing condition is provided such that once the medication has been placed into the

compartment to form the required dosages in accordance with a first set of instructions, the first fixing condition allows the retaining portion and container portion to be brought together and hold the medication in the compartments into which the same has been placed. However, in this first fixing condition, the engagement is not complete and therefore, if for whatever reason, there are subsequent changes to the medication which is to be provided in the pack for a particular patient, the engagement means can be released to allow the medication changes to occur. Prior to the apparatus being sent to a patient for use, the engagement means are moved to a second fixing condition in which the engagement means are irreversibly engaged or at least are engaged to such an extent that an attempt to withdraw the retaining portion from the container portion is evident such that in the second condition the engagement means are tamper evident.

In contrast to the conventional apparatus, preferably the sealing means has applied thereto information relating to the medication and/or the time period to which the compartments of the container means relate. Such information can for example be weekdays, dosage times or the like such that the common retainer portion and container portion can be used with the appropriate sealing means being inserted between the same to tailor the pack for a particular use.

In one embodiment, the sealing means can be provided with a range of different printing applied thereto such that one of the range of sealing means can be selected for use in association with a particular medication dosage regime. Alternatively, the sealing means is provided with a series of printed information thereon and said sealing means can be adapted by the user such that the required information is shown on the sealing means which is actually attached to the apparatus.

In a further embodiment, the compartment walls in the container portion are provided with at least one protrusion such that, in conjunction with the formation of the perforations or frangible portion on the sealing means, the parts of the sealing means which are movable as a result of breaking of the perforations to gain access to the compartment, and hence the medication, are retained by the protrusions lying inwardly of the compartment thereby allowing access to the medication to be achieved and removal of the medication to be achieved without the broken portions of the sealing means acting to prevent the same.

According to a second aspect of the present invention there is provided a method of assembling dispensing apparatus, said method including the steps of locating one or more items into one or more compartments of a container portion, locating sealing means over the compartments and retaining the sealing means in position using a retaining portion, the retaining portion having engagement means which engage with complementary engagement means provided on the container portion.

The advantage of the present invention is that there is no requirement for sealing equipment to be used to achieve tamper evident storage of medication. The apparatus is also inexpensive to manufacture.

In a further aspect of the invention there is provided dispensing apparatus for the selective dispensation of items therefrom, said dispensing apparatus including a container portion having one or more compartments formed therein for the containment of said items which are previously selectively placed therein, sealing means for location over said compartments and wherein

the sealing means is held in position with respect to said compartments by a retaining portion, said compartment portion and/or retaining portion having engagement means which cooperate to retain the sealing means in position.

In one embodiment the sealing means are held in position without the requirement for adhesive.

In a further aspect of the invention there is provided dispensing apparatus for medication, said items of medication selectively placed into a series of compartments in a container portion and retained in the same by a sealing means held in position by a retainer portion mechanically engaged with the container portion.

Typically the sealing means includes a series of perforated lines defining a series of areas in the sealing means which can be pushed through to open the sealing means, each of said areas located with respect to a compartment of the container so as to allow selective access to be gained to the medication.

Embodiments of the present invention will now be described with reference to the accompanying figures, wherein:

Figure 1 is a perspective view of partially assembled dispensing apparatus according to one embodiment of the present invention;

Figure 2 is a plan view of the sealing means for assembly with the apparatus in Figure 1;

Figure 3 is an enlarged cross sectional view of a compartment of the dispensing apparatus in figure 1 with the sealing means in figure 2 assembled therewith;

Figure 4 is a plan view of dispensing apparatus according to a further embodiment of the present invention;

Figure 5 is a perspective view of the dispensing apparatus in figure 3 when assembled;

Figures 6a-6c show examples of possible forms of perforations for use with the present invention;

Figure 7 shows a perspective view of a further embodiment of the invention;

Figure 8 shows two dispensing apparatus joined together;

Figure 9 illustrates part of the underside of the dispensing apparatus; and

Figure 10 illustrates the provision of a record card in accordance with a further embodiment of the invention.

Referring firstly to figures 1-3 and 5, there is illustrated dispensing apparatus 2 in the form of a pill container including a retaining portion 4 hingedly connected to a container portion 6 along edge 8 by hinges 10. Hinges 10 are integrally formed with retaining portion 4 and container portion 6 in this example.

Container portion 6 is in the form of a tray and includes a plurality of compartments 12 therein for the containment of predefined dosages of pills. In this example the compartments are substantially square in shape and include a base 14, side walls 16 and an open top 18. However, it is noted that the compartments can be any required shape and can be of such dimensions to include a single pill 15 or a plurality of pills as required. The compartments 12 are provided at spaced apart

locations in the tray and the openings of the compartments are defined in the upper panel surface 20 of the tray.

The retaining portion 4 is a planar member with a plurality of apertures 22 defined between upper and lower surfaces 24, 26 thereof respectively. Retaining portion 4 is movable between an open position shown in figure 1, wherein the lower surface 26 of the portion is a spaced distance apart from upper surface 20 of the container portion, and a closed position shown in figures 3 and 5, wherein the lower surface 26 of the retaining portion is adjacent to and substantially parallel to upper surface 20 of container portion 6. In the closed position, apertures 22 are substantially aligned with the openings 18 of compartments 12 and retaining portion 4 has the same number of apertures as container portion 6.

Engagement means are provided on the retaining portion 4 in the form of a plurality of pegs 28 which protrude outwardly of the lower surface 26 of the retaining portion. The pegs 28 are complementary in shape to apertures 30 provided in upper surface 20 of the container portion 6 and are locatable therein when the retaining portion 4 is in the closed position. The walls 32 defining apertures 30 are typically provided with a converging taper away from upper surface 20 to provide a funnel like shape to allow easy location of a peg 28 therein. Each of pegs 28 can be provided with a flange portion 34 adjacent a free end thereof to allow the peg 28 to be snap fitted with the free end 36 of walls 32 defining the aperture 30. This engagement can be irreversible or the flange and/or walls 32 can be sufficiently flexible to allow releasable engagement thereof.

In use, a required number of pills 15 are located in each compartment 12 by a doctor or pharmacist. Sealing means in the form of a sheet member 38 is provided for location between the

container portion 6 and retaining portion 4 when the apparatus is assembled. The sheet member 38 is held in place by the retaining portion 4, thereby removing the requirement for adhesive or other sealing steps to be undertaken by the pharmacist or medical person.

The sheet member 38 is typically formed from thin card but can be formed from any foil or plastic film like material. A plurality of apertures 40 are formed in member 38 which align with apertures 30 on container portion 6, when assembled thereby allowing pegs 28 of retaining portion 4 to pass therethrough when the retaining portion is moved to a closed position. A plurality of perforations 42 are formed in member 38 and have substantially the same dimensions as the openings 18 of compartments 12. As such, when a user wishes to access the medication contained in a particular compartment 12 of the assembled apparatus, they break the perforation portion corresponding to a compartment and retrieve the dose of pills therefrom.

Referring to figures 6a-6c, there are illustrated some examples of the perforation portions that could be used for allowing a user to gain access to compartments 12. In figure 6a, the perforations 42 are of substantially similar dimensions to the dimensions of opening 18. In figure 6b, the perforations 42' converge from the corners of opening 18 to a substantially central line. In figure 6c, perforations 42'' form a line passing between opposite edges corresponding to side walls of the opening.

Printed matter 44 can be provided on at least the upper surface 46 of the sheet member 38 to inform the user of the required dosage, dates and/or times at which the medication is to be taken, the name of the medication and/or other useful information. In addition, the sheet member 38 can be provided

with additional panels 48, 50 on either end thereof which can provide additional medication information thereon if required. The additional panels 48, 50 are typically defined in sheet member 38 along fold lines 52, 54 respectively. Panels 48, 50 can be folded over retaining portion 4 when in a closed position, as shown in figure 5, thereby preventing accidental breaking of the sealing means.

Whilst figures 1-3 and 5 show a dispensing apparatus including two columns of medication corresponding to a dual dosage system, further columns or rows of compartments can be provided depending on the required dosage required. For example, in figure 4 a four dose dispensing apparatus is illustrated.

Figure 7 illustrates a further embodiment of the dispensing apparatus in accordance with the invention, wherein there is again provided a container portion 102 with a series of compartments 104 for the reception of medication therein and each of the compartments represents a medication dose to be taken at a particular time. Provided in conjunction with the container portion is the retainer portion 106 between which there is sandwiched a sealing means 108 with the sealing means having a series of perforations which are provided to allow access, when broken, to the compartments 104 through the apertures 112 in the retainer means 106. The retainer means and sealing means are engaged with the container portion via engagement means 114 each of which comprises a peg 116 typically provided in this embodiment on the retaining portion and a reception aperture 118 provided on the underside of the container portion 102 and shown in more detail in Figure 9. The container portion also includes along a first elongate edge 120, a series of tabs 122 and provided along the opposing edge 124, a series of pins 126 as shown in detail in Figure 9. These

tabs and pins allow adjacent body portions to be brought together to form a dispensing apparatus of a larger size with the location between the adjacent body portions 102 and 102' being shown in detail in Figure 8 where it is shown how the edge 120 of the container portion 102 has been brought to lie adjacent to the edge 124 of the container portion 102' so as to allow the pins 126 at the edge 124 and 102' to pass through the apertures 130 in the tabs 122 of the container portion 102. In this arrangement, the sealing means may be provided of a size so as to pass across all of the compartments in the joined together body portions as illustrated.

The sealing means may also be provided with printing material thereon to allow an indication of dosage consumption requirements and this can be achieved, in one embodiment, by providing the sealing means to extend beyond the retaining portion such that printed information is visible as shown in Figure 7 wherein on the longitudinal edge 134 there is provided an indication of days and on the shorter edge 136 there is provided an indication of the particular time for the dosage to be consumed on each day.

In one embodiment, the sealing means can be provided in specific forms for specific packs or alternatively, can be provided with a series of sets of information printed thereon, which information can be detached from the sealing means as required by the person providing the medication so as to allow the sealing means to be adapted for particular medication provision requirements.

Figure 10 illustrates how a medication record card 140 can be attached to the dispensing apparatus by providing the peg 116 of the retaining portion 106 to pass through an aperture in the record card 142 and the apertures in the sealing means 108 and

the body portion 102 and passing in turn through the aperture 118 so as to secure the record card as part of the dispensing apparatus and thereby allow the record card to be used for attachment of medication information thereto and/or to allow medication information to be entered onto the record card in relation to the medication which is provided within the container.

The dispensing apparatus can be provided in any required shape or colour and can be made from any required material. However, in a preferred embodiment the apparatus is formed by injection moulding from a plastic material.

Claims

1. Dispensing apparatus for items of medication, said apparatus including a container portion having one or more compartments formed therein for the containment of said medication, sealing means for location over said compartments and wherein the sealing means is held in position with respect to said compartments by a retaining portion, said compartment portion and/or retaining portion having engagement means which cooperate to retain the sealing means in position.
2. Apparatus according to claim 1 wherein the sealing means is in the form of a sheet-like material.
3. Apparatus according to claim 1 wherein the sealing means is held in place by mutual engagement of the retaining portion and container portion engagement means.
4. Apparatus according to claim 1 wherein at least part of the sealing means is substantially transparent to allow a user to view medication contained in the apparatus.
5. Apparatus according to claim 1 wherein the sealing means is provided with perforation or frangible means at spaced locations to allow a user to access a compartment of the container portion by breaking and/or removing a portion of the sealing means.
6. Apparatus according to claim 5 wherein the provision of the perforations or frangible means, apertures in the retaining portion are provided in alignment with the openings into the compartments in the container portion to allow access to medication in the compartments.

7. Apparatus according to claim 6 wherein access to one of the compartments can be gained independently of access to the other compartments in the container portion.

8. Apparatus according to claim 1 wherein the engagement means between the retaining portion and the container portion comprise a series of protrusions provided in one or both of the container or body portion at spaced locations and the housing therefor provided in the other of the container or body portion at said spaced locations.

9. Apparatus according to claim 8 wherein the fitment of the protrusion into a respective housing is provided in a two-stage manner such that in a first stage, the protrusion can be removed from the housing and in a second condition, removal of the protrusion from the housing is tamper evident.

10. Apparatus according to claim 1 wherein the sealing means includes information material relating to the medication and/or medication consumption times.

11. Apparatus according to claim 10 wherein the information contained on the sealing means, when the sealing means is placed in alignment with the compartments on the container portion, determines the consumption times of the medication held in the said compartments.

12. Apparatus according to claim 1 wherein the apparatus includes a record card fixed to the apparatus, said record card including details relating to the medication in the compartments of the dispensing apparatus.

13. Apparatus according to claim 12 wherein the records card is attached by locating the same between a container portion and retaining portion.

14 Apparatus according to claim 1 wherein the apparatus is modular to allow a dispensing apparatus pack of a required size to be formed by joining together respective container portions side to side via matching location means.

15 Apparatus according to claim 14 wherein the apparatus is formed to provide a sufficient number of compartments to suit the amount of medication which is required to be dispensed to a patient by joining the portions together to provide an increased number of medication containing compartments.

16 Apparatus according to claim 14 wherein the container portion compartments of the formed apparatus are overlaid by a single common sealing means and/or retainer portion.

17 Dispensing apparatus for the selective dispensation of items therefrom, said dispensing apparatus including a container portion having one or more compartments formed therein for the containment of said items which are previously selectively placed therein, sealing means for location over said compartments and wherein the sealing means is held in position with respect to said compartments by a retaining portion, said compartment portion and/or retaining portion having engagement means which cooperate to retain the sealing means in position.

18 Apparatus according to claim 17 wherein the sealing means are held in position without the requirement for adhesive.

19 Dispensing apparatus for medication, said items of medication selectively placed into a series of compartments in a container portion and retained in the same by a sealing means held in position by a retainer portion mechanically engaged with the container portion.

20 Apparatus according to claim 19 wherein the sealing means includes a series of perforated lines defining a series of areas in the sealing means which can be pushed through to open the sealing means, each of said areas located with respect to a compartment of the container so as to allow selective access to be gained to the medication.

21. A method of assembling a dispensing apparatus, said method including selectively locating one or more items of medication into one or more compartments of a container portion, locating sealing means over a compartment and retaining the sealing means in position using a retaining portion, the retaining portion having engagement means which engage with complimentary engagement means provided on the container portion.

1/5

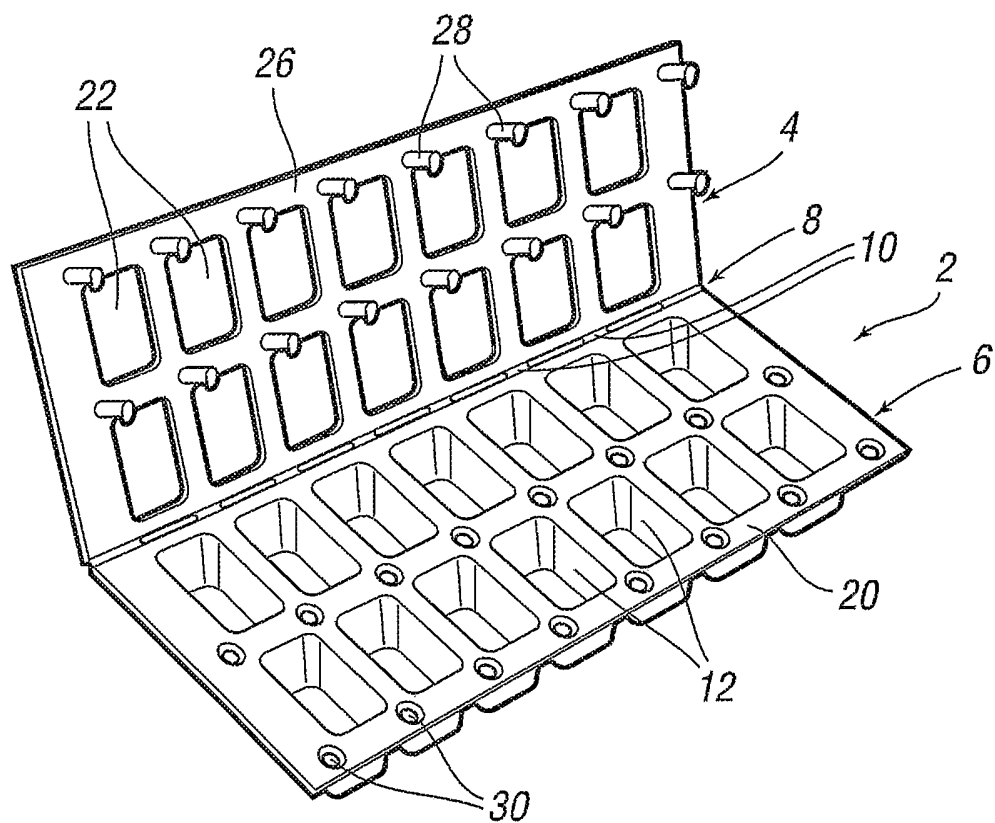

FIG. 1

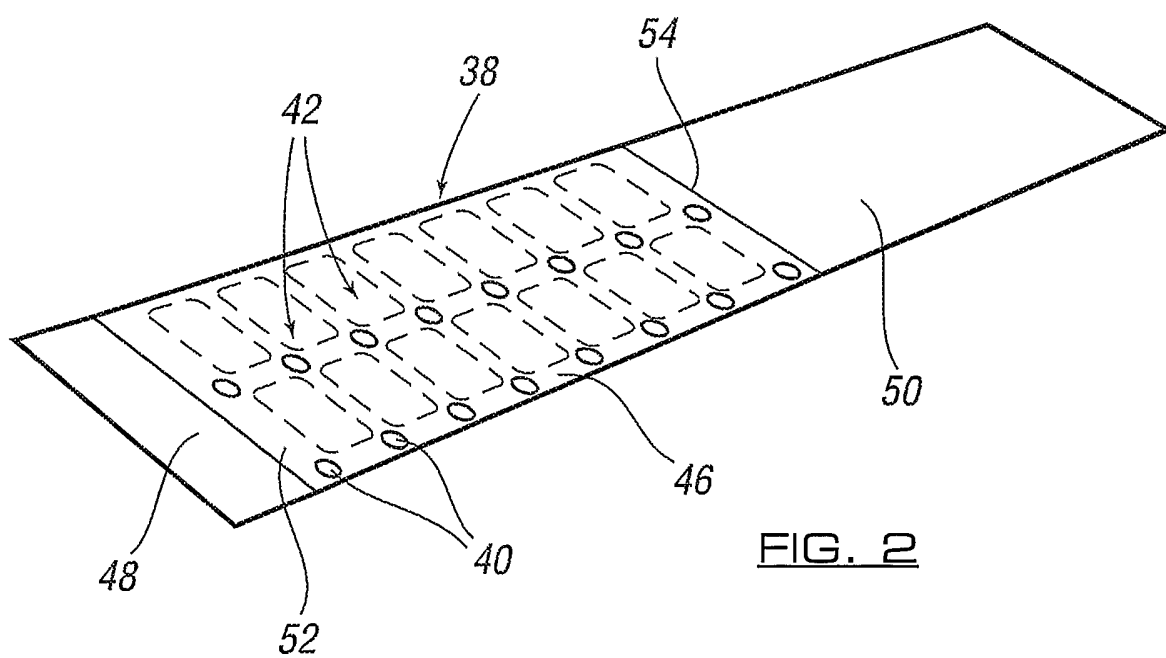

FIG. 2

2/5

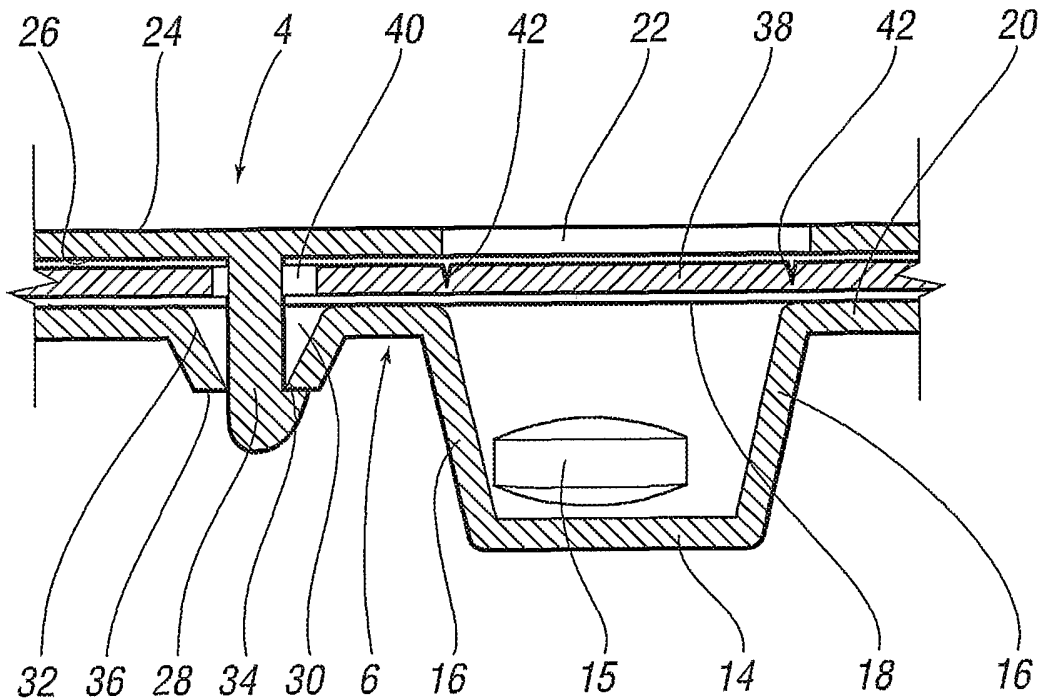

FIG. 3

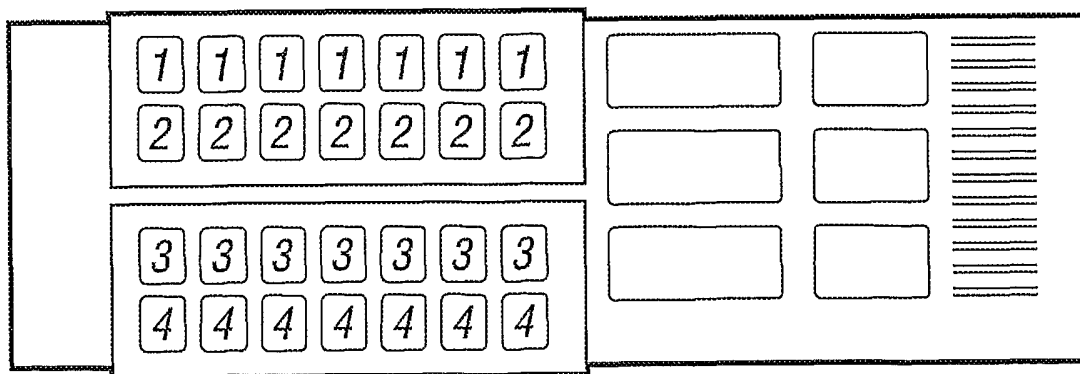

FIG. 4

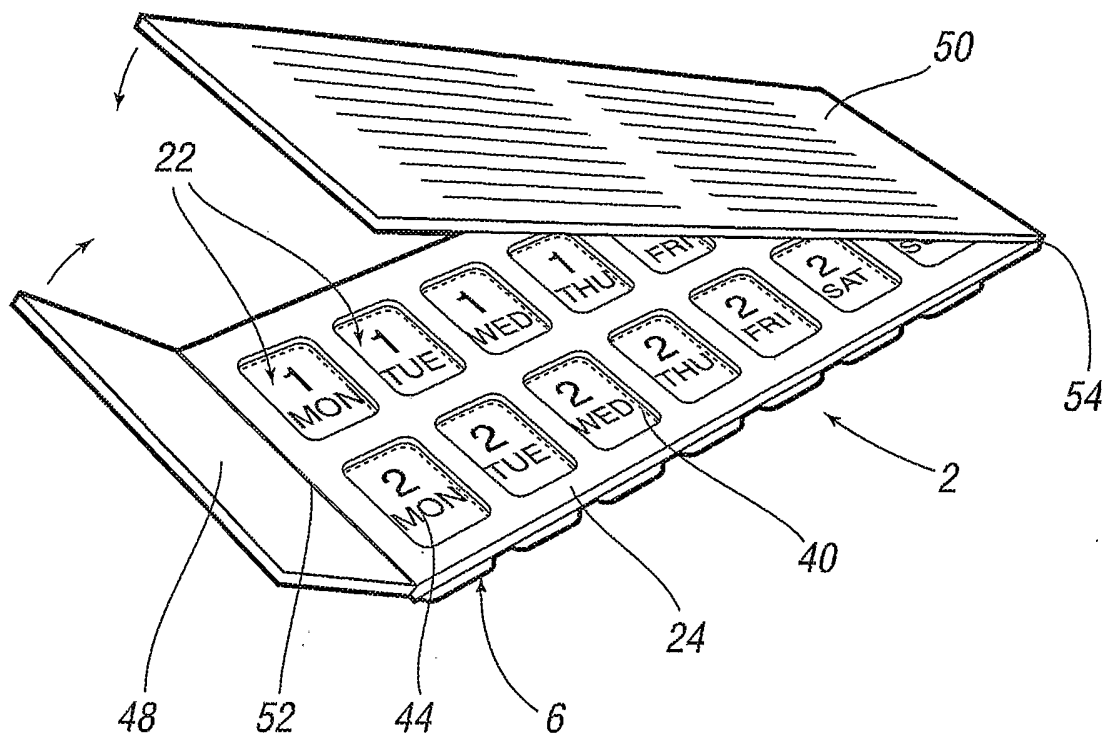

FIG. 5

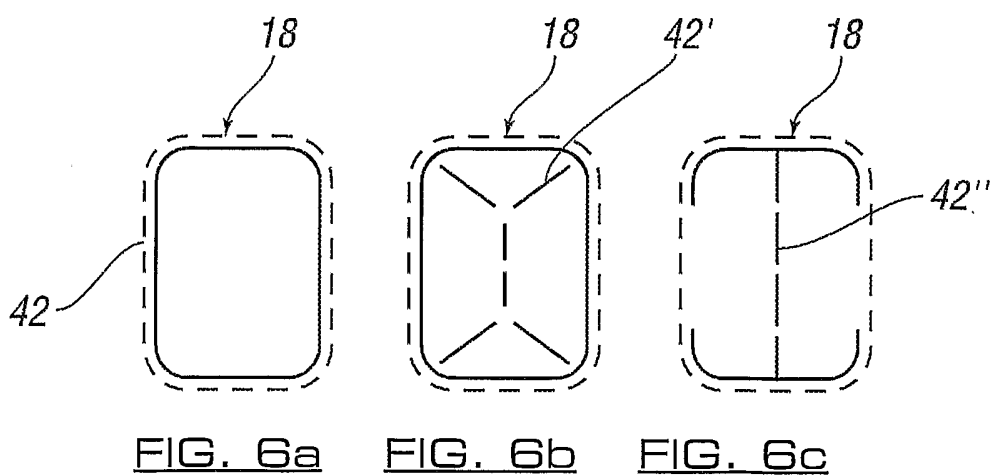

FIG. 6a

FIG. 6b

FIG. 6c

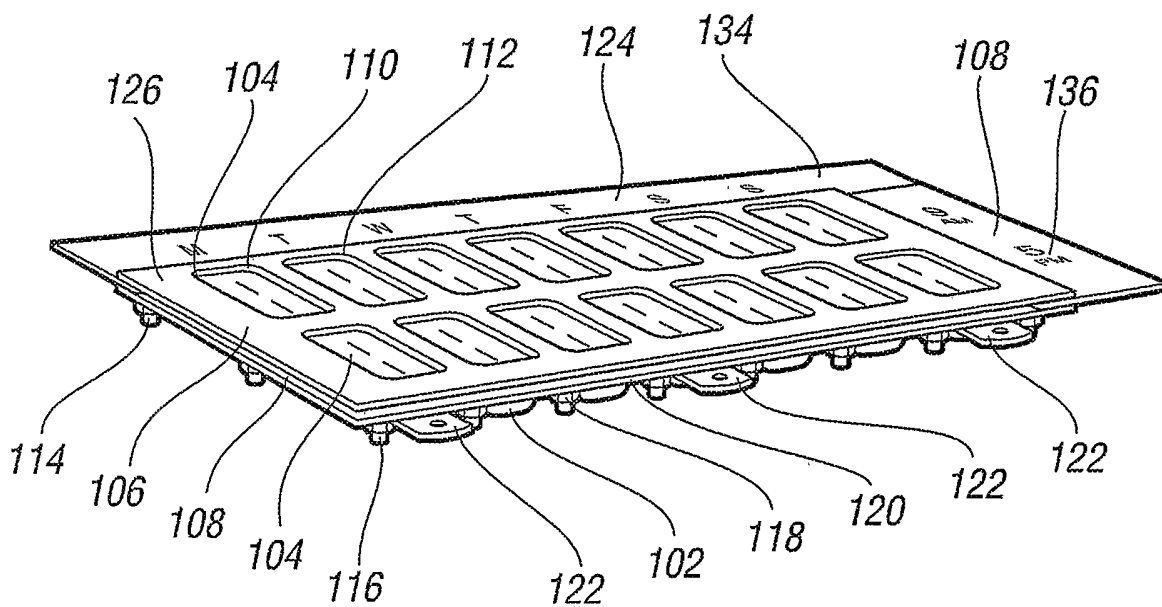

FIG. 7

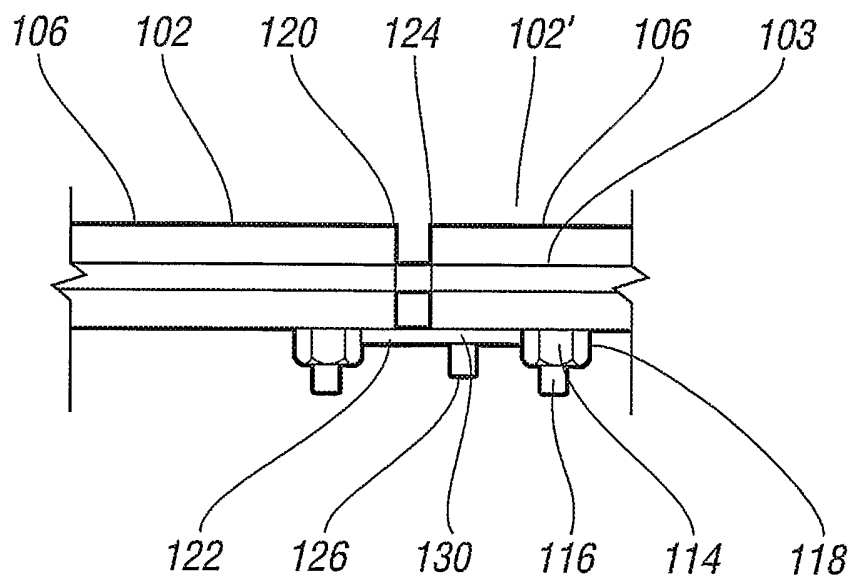

FIG. 8

5/5

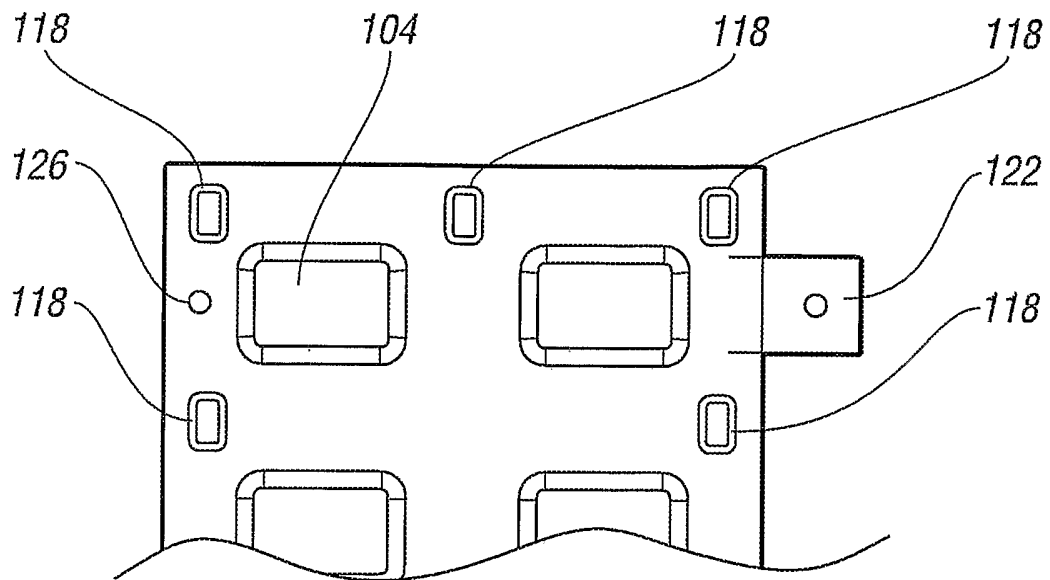

FIG. 9

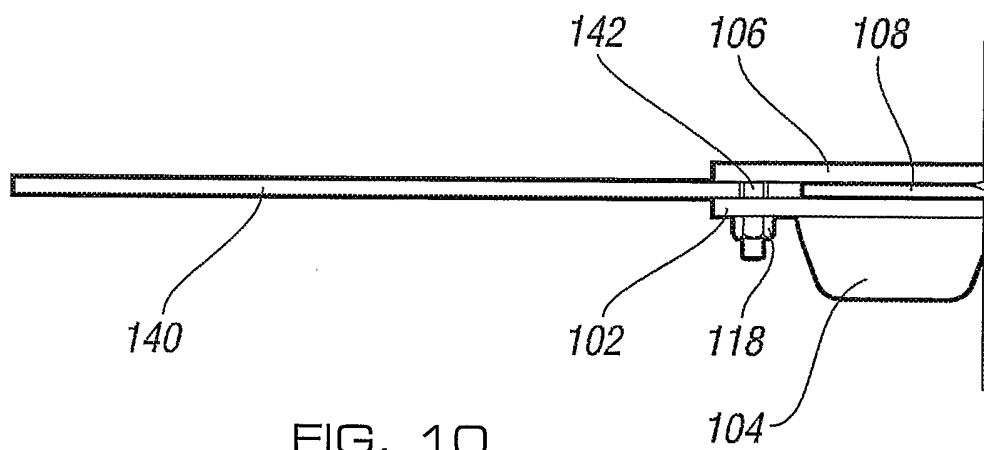

FIG. 10

INTERNATIONAL SEARCH REPORT

PCT/GB2004/003739

A. CLASSIFICATION OF SUBJECT MATTER IPC 7 B65D75/34 B65D75/22 B65D73/00 A61J7/04				
According to International Patent Classification (IPC) or to both national classification and IPC				
B. FIELDS SEARCHED Minimum documentation searched (classification system followed by classification symbols) IPC 7 B65D A61J				
Documentation searched other than minimum documentation to the extent that such documents are included in the fields searched				
Electronic data base consulted during the international search (name of data base and, where practical, search terms used) EPO-Internal				
C. DOCUMENTS CONSIDERED TO BE RELEVANT				
Category °	Citation of document, with indication, where appropriate, of the relevant passages	Relevant to claim No.		
A	GB 2 277 920 A (BRYANT NEAL CHARLES) 16 November 1994 (1994-11-16) page 2, paragraph 6; figures 1-3	1, 17, 21		
A	EP 0 329 462 A (MINNESOTA MINING & MFG) 23 August 1989 (1989-08-23) column 2, lines 40-64 column 3, lines 1-18; figure 1	1, 17, 21		
A	GB 1 099 499 A (ASPRO NICHOLAS LTD) 17 January 1968 (1968-01-17) page 3, lines 4-23; figure 5	1, 17, 21		
A	US 5 323 907 A (KALVELAGE JOHN D) 28 June 1994 (1994-06-28) abstract; figures 1-7	1, 17, 21		
----- -/--				
<input checked="" type="checkbox"/> Further documents are listed in the continuation of box C.				
<input checked="" type="checkbox"/> Patent family members are listed in annex.				
° Special categories of cited documents :				
<table style="width: 100%; border: none;"> <tr> <td style="width: 50%; vertical-align: top; padding: 5px;"> *A* document defining the general state of the art which is not considered to be of particular relevance *E* earlier document but published on or after the international filing date *L* document which may throw doubts on priority claim(s) or which is cited to establish the publication date of another citation or other special reason (as specified) *O* document referring to an oral disclosure, use, exhibition or other means *P* document published prior to the International filing date but later than the priority date claimed </td> <td style="width: 50%; vertical-align: top; padding: 5px;"> *T* later document published after the international filing date or priority date and not in conflict with the application but cited to understand the principle or theory underlying the invention *X* document of particular relevance; the claimed invention cannot be considered novel or cannot be considered to involve an inventive step when the document is taken alone *Y* document of particular relevance; the claimed invention cannot be considered to involve an inventive step when the document is combined with one or more other such documents, such combination being obvious to a person skilled in the art. *&* document member of the same patent family </td> </tr> </table>			*A* document defining the general state of the art which is not considered to be of particular relevance *E* earlier document but published on or after the international filing date *L* document which may throw doubts on priority claim(s) or which is cited to establish the publication date of another citation or other special reason (as specified) *O* document referring to an oral disclosure, use, exhibition or other means *P* document published prior to the International filing date but later than the priority date claimed	*T* later document published after the international filing date or priority date and not in conflict with the application but cited to understand the principle or theory underlying the invention *X* document of particular relevance; the claimed invention cannot be considered novel or cannot be considered to involve an inventive step when the document is taken alone *Y* document of particular relevance; the claimed invention cannot be considered to involve an inventive step when the document is combined with one or more other such documents, such combination being obvious to a person skilled in the art. *&* document member of the same patent family
A document defining the general state of the art which is not considered to be of particular relevance *E* earlier document but published on or after the international filing date *L* document which may throw doubts on priority claim(s) or which is cited to establish the publication date of another citation or other special reason (as specified) *O* document referring to an oral disclosure, use, exhibition or other means *P* document published prior to the International filing date but later than the priority date claimed	*T* later document published after the international filing date or priority date and not in conflict with the application but cited to understand the principle or theory underlying the invention *X* document of particular relevance; the claimed invention cannot be considered novel or cannot be considered to involve an inventive step when the document is taken alone *Y* document of particular relevance; the claimed invention cannot be considered to involve an inventive step when the document is combined with one or more other such documents, such combination being obvious to a person skilled in the art. *&* document member of the same patent family			
Date of the actual completion of the international search	Date of mailing of the international search report			
2 December 2004	21/12/2004			
Name and mailing address of the ISA European Patent Office, P.B. 5818 Patentlaan 2 NL - 2280 HV Rijswijk Tel. (+31-70) 340-2040, Tx. 31 651 epo nl, Fax: (+31-70) 340-3016	Authorized officer Visentin, M			

INTERNATIONAL SEARCH REPORT

PCT/GB2004/003739

C.(Continuation) DOCUMENTS CONSIDERED TO BE RELEVANT

Category *	Citation of document, with indication, where appropriate, of the relevant passages	Relevant to claim No.
A	US 4 039 080 A (CAPPUCILLI JOSEPH ANTHONY) 2 August 1977 (1977-08-02) the whole document -----	1, 17, 21

INTERNATIONAL SEARCH REPORT

Information on patent family members

GB2004/003739

Patent document cited in search report	A	Publication date	Patent family member(s)	Publication date
GB 2277920	A	16-11-1994	NONE	
EP 0329462	A	23-08-1989	US 4802584 A CA 1327761 C CA 1334954 C DE 68911166 D1 EP 0329462 A2 ES 2048280 T3 JP 1254573 A US 4844246 A	07-02-1989 15-03-1994 28-03-1995 20-01-1994 23-08-1989 16-03-1994 11-10-1989 04-07-1989
GB 1099499	A	17-01-1968	DE 1931178 U NL 6515194 A	13-01-1966 27-05-1966
US 5323907	A	28-06-1994	NONE	
US 4039080	A	02-08-1977	NONE	