

(19) World Intellectual Property Organization
International Bureau



(43) International Publication Date
7 June 2007 (07.06.2007)

PCT

(10) International Publication Number
WO 2007/063526 A1

- (51) International Patent Classification:
B62J 1/00 (2006.01)
- (21) International Application Number:
PCT/IB2006/054556
- (22) International Filing Date:
1 December 2006 (01.12.2006)
- (25) Filing Language: English
- (26) Publication Language: English
- (30) Priority Data:
VI2005A000321 2 December 2005 (02.12.2005) IT
- (71) Applicant (for all designated States except US): **SELLE ROYAL S.P.A.** [IT/IT]; Via Vittorio Emanuele, 119, I-36050 Pozzoleone (IT).

AT, AU, AZ, BA, BB, BG, BR, BW, BY, BZ, CA, CH, CN, CO, CR, CU, CZ, DE, DK, DM, DZ, EC, EE, EG, ES, FI, GB, GD, GE, GH, GM, GT, HN, HR, HU, ID, IL, IN, IS, JP, KE, KG, KM, KN, KP, KR, KZ, LA, LC, LK, LR, LS, LT, LU, LV, LY, MA, MD, MG, MK, MN, MW, MX, MY, MZ, NA, NG, NI, NO, NZ, OM, PG, PH, PL, PT, RO, RS, RU, SC, SD, SE, SG, SK, SL, SM, SV, SY, TJ, TM, TN, TR, TT, TZ, UA, UG, US, UZ, VC, VN, ZA, ZM, ZW.

(84) Designated States (unless otherwise indicated, for every kind of regional protection available): ARIPO (BW, GH, GM, KE, LS, MW, MZ, NA, SD, SL, SZ, TZ, UG, ZM, ZW), Eurasian (AM, AZ, BY, KG, KZ, MD, RU, TJ, TM), European (AT, BE, BG, CH, CY, CZ, DE, DK, EE, ES, FI, FR, GB, GR, HU, IE, IS, IT, LT, LU, LV, MC, NL, PL, PT, RO, SE, SI, SK, TR), OAPI (BF, BJ, CF, CG, CI, CM, GA, GN, GQ, GW, ML, MR, NE, SN, TD, TG).

- (72) Inventor; and
- (75) Inventor/Applicant (for US only): **SEGATO, Stefano** [IT/IT]; Corso Padova, 140/a, I-36100 Vicenza (IT).
- (74) Agent: **MAROSCIA, Antonio**; Maroscia & Associati SRL, Contra's. Caterina, 29, I-36100 Vicenza (IT).
- (81) Designated States (unless otherwise indicated, for every kind of national protection available): AE, AG, AL, AM,

Published:
— with international search report
— before the expiration of the time limit for amending the claims and to be republished in the event of receipt of amendments

For two-letter codes and other abbreviations, refer to the "Guidance Notes on Codes and Abbreviations" appearing at the beginning of each regular issue of the PCT Gazette.

(54) Title: QUICK-MOUNT FRAME STRUCTURE, PARTICULARLY FOR BICYCLE SADDLES OR SIMILAR SUPPORTS, PROCESS OF MAKING SUCH STRUCTURE AND SADDLE INCORPORATING SAME

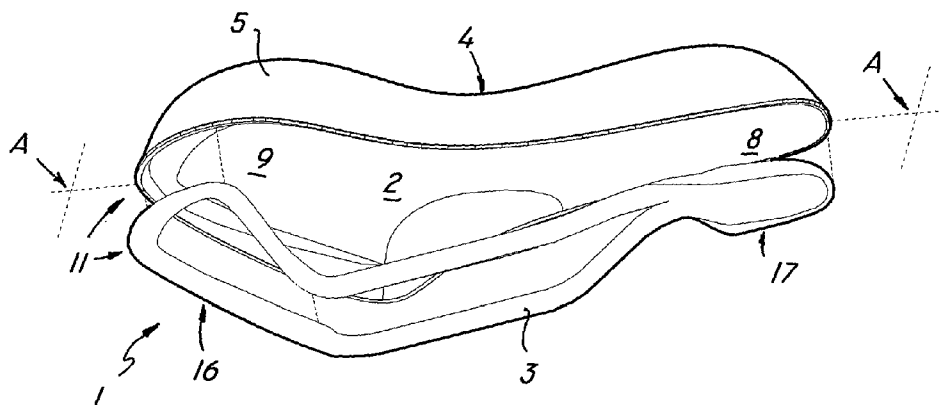

(57) Abstract: A quick-mount frame structure, particularly for bicycle saddles and similar supports. The structure comprises at least one shell (2) having a top user-supporting surface (6) and a bottom surface (7), said shell (2) having a front portion (8) and a rear portion (9), saddle rails (3) for attachment of said shell (2) to a movable or stationary support, said rails (3) having an outer peripheral edge (10) and means for stable connection between said rails (3) and said shell (2). The connection means include snap engagement means (11) at least at one of said front (8) and rear (9) portions of said shell (2) for quick connection between the shell (2) and the rails (3). A process for making the above structure, and a saddle incorporating such structure.

WO 2007/063526 A1

QUICK-MOUNT FRAME STRUCTURE, PARTICULARLY FOR BICYCLE SADDLES OR SIMILAR SUPPORTS, PROCESS OF MAKING SUCH STRUCTURE AND SADDLE INCORPORATING SAME

5

Field of the invention

The present invention finds application in the field of sport and leisure accessories and particularly relates to a quick-mount frame structure, e.g. for bicycle saddles or movable or stationary pedal-operated machines, as well as to a process of making such frame structure.

The invention further relates to a saddle incorporating the above frame structure.

Background of the invention

15

Saddles, particularly for bicycles or pedal-operated machines in general, are known to be connected to the support by means of a relatively rigid but elastic saddle frame, formed of a metal or composite material, commonly known as "rails".

20

Saddle rails are further known to generally comprise one or more specially shaped elongate elements, each having a middle portion designed to be mounted to the underlying support and an end portion, partly convergent and partly divergent, designed for connection with the saddle or its shell or supporting core.

25

The rails typically comprise a pair of elongate members, which are connected to the saddle by coupling respective end portions into special receptacles on the bottom surface of the saddle or its shell.

30 This prior art solution has a few apparent drawbacks.

First, this kind of fit coupling to loosen and to become rather instable with time and

extensive use.

Furthermore, when using this kind of coupling, pressure between the rails and the saddle is exerted on a few small areas, thereby involving high stress
5 concentration.

The receptacles for the ends of the rails are rather large and increase the size of the saddle, thereby adding weight to the bicycle and reducing cyclists' performances, especially during competitions and extreme sport activity.
10

This saddle/rails fit is known to require a saddle pre-tensioning step, during which the shell is curved or widened to temporarily increase the distance between the receptacles to a sufficient extent as to allow the rails to be accommodated therein. Once the rails have been mounted, the saddle is released, with the shell assuming
15 its initial configuration, while the receptacles engage the ends of the rails.

These steps require appropriate equipment and arrangements, which have to be adapted and calibrated for each saddle model and shell and saddle base material. Adjustments have to be particularly accurate when using frames of composite
20 materials, because the smallest calibration error might cause considerable stresses, which might affect shell integrity with time.

Summary of the invention

25 The main object of this invention is to overcome the above drawbacks, by providing a frame structure having high efficiency, durability and cost-effectiveness.

A particular object is to provide a frame structure in which the rails/shell
30 connection is particularly easy and stable.

A further object is to provide a frame structure whose light weight and small size

make it particularly suitable for competitions.

Another object is to provide a frame structure that allows an optimized distribution of stresses generated by user pressure on the structure.

- 5 Yet another object of the invention is to provide a process for making a frame structure, that does not cause excessive mechanical stresses on the shell during connection thereof to the rails.

Another object of the invention is to provide a saddle that uses the above frame
10 structure.

These and other objects, as better explained hereafter, are fulfilled by a frame structure which, in accordance with claim 1, comprises at least one shell having a top user-supporting surface and a bottom surface, said shell having a front portion
15 and a rear portion; saddle rails designed for connection of said shell to a movable or stationary support, said rails having an outer peripheral edge and means for stable connection between said rails and said shell, characterized in that said connection means comprise snap engagement means at least at one of said front and rear portions of said shell.

20

Thanks to this particular configuration, the frame structure of the invention allows quick and easy connection between the shell and the rails, for maximized assembly simplicity.

- 25 Furthermore, since there is no need to provide receptacles on the shell, the frame structure has a very light weight and a small size, and does not restrict cyclist's performances, whereby it is particularly suitable for competitions.

It will be appreciated that the snap engagement means may be either incorporated
30 in the shell and/or the rails, or associated to any portion of the rails and/or the shell.

Advantageously, the snap engagement means may include at least one element that projects downwards from the bottom surface of the shell for interaction with the outer peripheral edge of the rails.

- 5 As an illustrative, non-limiting example, such projecting member may comprise a certain number of fins substantially vertically projecting in any position from the bottom surface of the shell.

10 These fins may be made of a flexible plastic or metal material, which allows them to bend upon insertion of the rails, and to snap into the original configuration, to engage the outer or inner edge of the rails, or into a receptacle specially formed thereon.

15 For this purpose, the fins may have a substantially straight shape and/or an inward or outward concavity for receiving the rails edge.

Alternatively, the projecting member may include one or more fastening edges substantially vertical projecting in any position from the bottom surface of the shell. The above considerations regarding materials and configuration also apply to the
20 edge of the latter embodiment.

Conveniently, each projecting member may be formed at least partly of an outer peripheral edge of the shell. Furthermore, the rails may comprise a substantially rigid body having a substantially annular continuous shape.
25

The rails may be of the open or closed ring type, and have an either monolithic or composite construction.

30 Thanks to this particular configuration, the frame structure of the invention allows optimized distribution of the stresses exerted by the user on the top surface of the shell, while avoiding pressure peaks at the ischial regions of his/her body. By this configuration of the rails, the rails-shell contact points will be moved from the

inside to the periphery of the shell, thereby utilizing all the elasticity thereof.

Optionally, at least one layer of adhesive may be interposed between the contact surfaces of the shell and the rails, to provide a particularly stable and effective connection therebetween.

5

In another aspect, the invention provides a saddle as defined in claim 16, which comprises a bearing structure designed to contact a user's body, characterized in that it comprises the above frame structure, in which the bearing structure is associated to the shell.

10

In yet another aspect, the invention provides a process for making a frame structure which, as defined in claim 17, is characterized in that it comprises the following steps: providing at least one shell having a bottom surface and a top user-supporting surface, said shell having a front portion and a rear portion; providing saddle rails to be secured to the bottom surface of said shell, said rails having an outer peripheral edge; forming means for stable connection between said rails and said shell, which comprise snap engagement means; connecting said rails to said shell by snap engagement at least at one of said front and rear portions of said shell to allow quick connection thereof.

15
20

Brief Description of the Drawings

Further features and advantages of the invention will be more apparent from the detailed description of a preferred, non-exclusive embodiment of a frame structure according to the invention, which is described as a non-limiting example with the help of the annexed drawings, in which:

25 FIG. 1 is an exploded perspective view of a saddle comprising the frame structure according to the invention;

FIG. 2 is a perspective view of the rails of the structure according to the invention;

30 FIG. 3 is a perspective view of the shell of the structure according to the invention;

FIG. 4 is a perspective view of the structure of the invention, as taken along a plane A-A;

FIG. 5 is an exploded plan view of the structure of the invention, as taken along the plane A-A;

5 FIGS. 6 and 7 are enlarged views of a few details of FIG. 5.

Detailed description of a preferred embodiment

Referring to the above figures, the frame structure of the invention, generally designated by numeral 1, may be used to connect a human body support to a lower support, not shown.

In the illustrated embodiment, the human body support is a saddle for a bicycle or a pedal-operated machine, whereas the support may be movable, such as a bicycle or motorcycle frame, or stationary, such as an exercise bicycle frame.

As shown in FIG. 1, the frame structure 1 may comprise a shell 2 and saddle rails 3.

20 The shell 2 may have a top surface 4 designed to contact a user's body. This surface 4 may be the top face of a layer 5 of resilient material, such as foam, rubber, gel or the like. A protective layer, e.g. made of leather, imitation leather, plastic, waterproofed material, Lycra® or the like, may be provided thereon.

25 As shown in FIG. 5, the shell 2 may be formed of a rigid or semirigid and elastically deformable material, selected from natural, synthetic and preferably composite materials.

The shell 2 may have a top surface 6 facing a user's body and a bottom surface 7 for connection to the rails 3.

As also shown in FIG. 3, the shell 2 may have an elongate front portion 8 and a

widened rear portion 9.

The rails 3 for securing the shell 2 to the bicycle frame 2 may have an outer peripheral edge 10, as shown in Fig. 2.

- 5 Means may be further provided for stable connection between the rails 3 and the shell 2, including snap engagement means, generally designated by numeral 11.

These may include an outer peripheral edge 12 of the shell 2, which is designed to interact with the outer peripheral edge 10 of the rails 3.

10

For this purpose, as best shown in FIGS. 4 and 5, the outer peripheral edge 12 may have an inner concave surface 13 defining a receptacle for the outer peripheral edge 10 of the rails 3, having an undercut 14 with respect to the latter.

- 15 FIG. 2 shows a preferred non-exclusive embodiment of the rails 3, which may consist of a substantially cylindrical rigid body 15 having a continuous annular shape, with a widened rear portion 16 and a tapered front portion 17. As shown in the Figures, the widened portion 16 of the rails 3 may snap into the corresponding widened portion 9 of the shell 2, and the tapered portion 17 of the rails 3 may snap
20 into the corresponding tapered portion 8 of the shell 2.

The latter may include a bulb-shaped end 18, which is substantially complementary to the corresponding area 19 of the bottom surface 7 of the shell 2.

25

Preferably, but without limitation, the body 15 may be made from a composite material reinforced with fibers selected from Kevlar, glass fiber, carbon fiber or long chain polyethylene (DYNEEMA®).

- 30 As best shown in FIGS. 6 and 7, the rails may have front and rear bearing surfaces 20 and 21, which are designed to at least partly contact the bottom surface 7 of the shell 2, and whose shape is substantially complementary to that of

the corresponding areas 19 and 22 of the bottom surface 7 of the shell 2, for perfect direct contact therewith.

Furthermore, for a more stable connection between the rails and the shell, a layer
5 of adhesive may be interposed therebetween, designated with numeral 23 in FIGS. 6 and 7.

The above frame structure may be fabricated using a process that includes at least the following steps.

10

Once the shell 2 and the rails 3 have been formed, possibly by separate processes and at different times, means for stable rails/shell connection, including the snap engagement means 11, may be formed at the bottom surface 7 of the shell 2.

15

This step may be followed by a connection step, in which the rails 3 are snap engaged with the shell 2, possibly preceded by a bonding step, in which a layer of adhesive 23 is interposed therebetween.

20

In order to prevent any undesired disengagement between the rails 3 and the shell 2, a step may be provided in which an undercut 14 with respect to the outer peripheral edge 10 of the rails 3 is formed in the shell 2.

25

Thanks to the provision of the snap engagement means, the process of the invention allows to omit the shell pre-tensioning step, which is needed in prior art processes.

30

The above disclosure clearly shows that the structure of the invention fulfills the intended objects and particularly meets the requirement of providing a frame structure whose rails-shell connection is particularly easy and stable.

The provision of the snap means 11 affords a particularly easy and quick

connection of the rails 3 to the shell 2. Also, the structure of the invention has a light weight and a compact size, which make it particularly suitable for making competition saddles.

5 Such structure may be further formed without providing a forced frame pretensioning step, which is typically required in prior art, wherefore the frame will not be subjected to any stress. The process of the invention will reduce such step to a slight deformation of the shell 2, to "open" the snap means 11 and allow connection thereof to the rails 3. This slight pretensioning step is limited to the
10 assembly process, whereby no pretensioning occurs during normal use of the structure 1.

The structure of the invention is susceptible of a number of modifications and changes all falling within the scope of the invention defined in the appended
15 claims. All the details thereof may be replaced by other technically equivalent parts, and the materials may vary depending on different needs, without departure from the scope of the invention.

While the structure has been described with particular reference to the
20 accompanying figures, the numerals referred to in the disclosure and claims are only used for the sake of a better intelligibility of the invention and shall not be intended to limit the claimed scope in any manner.

The instant application is based upon and claims priority of patent application
25 no. VI2005A000321, filed on 02.12.2005 in Italy, the disclosure of which is hereby expressly incorporated here in reference thereto.

CLAIMS

1. A quick-mount frame structure, particularly for bicycle saddles or similar supports, comprising:
- 5 - at least one shell (2) having a top user-supporting surface (6) and a bottom surface (7), said shell (2) having a front portion (8) and a rear portion (9);
- saddle rails (3) for attachment of said shell (2) to a movable or stationary support, said rails (3) having an outer peripheral edge (10);
- means for stable connection between said rails (3) and said shell (2);
- 10 characterized in that said connection means include snap engagement means (11) at least at one of said front (8) and rear (9) portions of said shell (2) for quick connection between the shell (2) and the rails (3).
2. Structure as claimed in claim 1, characterized in that said snap engagement
- 15 means (11) include at least one element that projects downwards from said bottom surface (7) of said shell (2) for interaction with an outer peripheral edge (10) of said rails (3).
3. Structure as claimed in claim 2, characterized in that said at least one
- 20 projecting element is at least partly formed of an outer peripheral edge (12) of said shell (2).
4. Structure as claimed in claim 3, characterized in that said outer peripheral
- edge (12) has an inner concave surface (13) defining a receptacle for the outer
- 25 peripheral edge (10) of said rails (3).
5. Structure as claimed in claim 4, characterized in that said outer peripheral
- edge (12) of the shell (2) has a portion (14) that is at least partly undercut with respect to the outer peripheral edge (10) of said rails (3).
- 30
6. Structure as claimed in claim 1, characterized in that said rails (3) have at least one front or rear bearing surface (20, 21) which is designed to at least partly

contact the bottom surface (7) of said shell (2).

7. Structure as claimed in claim 6, characterized in that said bearing surfaces (20, 21) have a shape that is substantially complementary to the corresponding areas (19, 22) of the bottom surface (7) of said shell (2) for direct contact therebetween.

8. Structure as claimed in claim 1, characterized in that said rails (3) comprise a substantially rigid body (15) having a substantially annular continuous shape.

9. Structure as claimed in claim 8, characterized in that said annular body (15) has a widened rear portion (16) and a tapered front portion (17).

10. Structure as claimed in claim 9, characterized in that said tapered front portion (17) has a substantially bulb-shaped end (18) whose shape is substantially complementary to that of the corresponding area (19) of the bottom surface (7) of said shell (2).

11. Structure as claimed in claim 8, characterized in that said annular body (15) has a substantially cylindrical structure.

12. Structure as claimed in claim 8, characterized in that said body (15) is made from a composite material reinforced with fibers selected from Kevlar, glass fiber, carbon fiber.

13. Structure as claimed in claim 1, characterized in that said shell (2) is made of an elastically deformable material.

14. Structure as claimed in claim 13, characterized in that said elastically deformable material is selected from natural, synthetic or composite materials.

15. Structure as claimed in claim 1, characterized in that at least one layer of

adhesive (23) is interposed between the contact surfaces of said shell (2) and said rails (3).

16. A human body support, such as a saddle for a bicycle, a pedal-operated
5 machine or the like, comprising a bearing structure (4) designed to contact a user's
body, characterized in that it comprises a frame structure as claimed in any one of
the preceding claims, said bearing structure (4) being associated to said shell (2).

17. A process for making a frame structure as claimed in any one of the
10 preceding claims, characterized in that it comprises at least the steps of:

- providing at least one shell (2) having a bottom surface (7) and a
top user-supporting surface (6), said shell (2) having a front portion (8) and a rear
portion (9);
- providing saddle rails (3) for attachment of said shell (2) to the
15 bottom surface, said rails (3) having an outer peripheral edge (10);
- forming means for stable connection between said rails (3) and said
shell (2), including snap engagement means (11);
- connecting together said rails (3) and said shell (2) by snap
engagement at least at one of said front (8) and rear (9) portions of said shell (2)
20 for quick connection between the shell (2) and the rails (3).

18. Process as claimed in claim 17, characterized in that said step of
connection of said rails (3) with said shell (2) comprises a step in which they are
bonded by at least one layer of adhesive (23).
25

19. Process as claimed in claim 17, characterized in that it includes the step of
forming an undercut (14) with respect to the outer peripheral edge (10) of said rails
(3) for preventing any accidental disengagement of said rails (3) from said shell
(2).

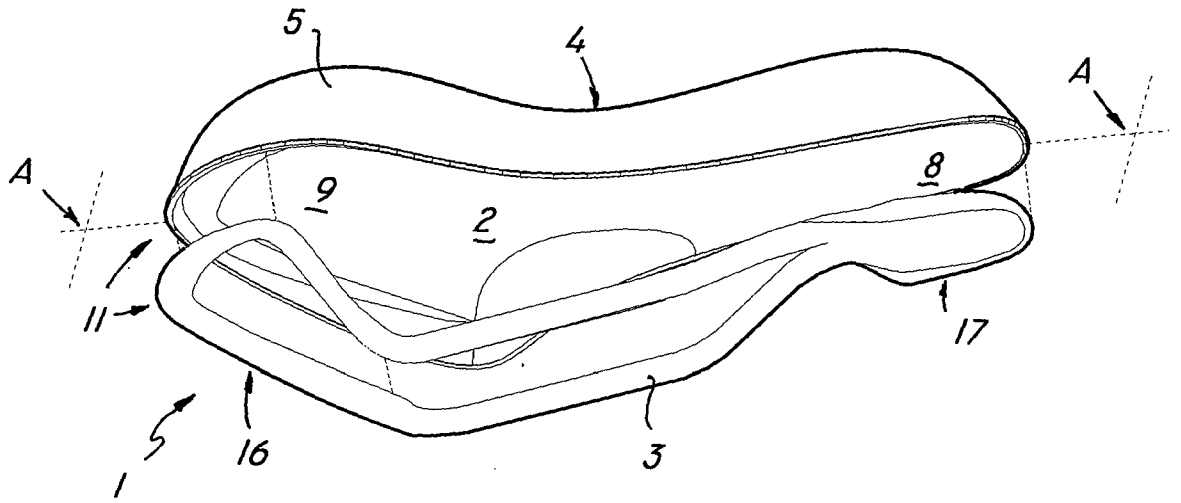

FIG. 1

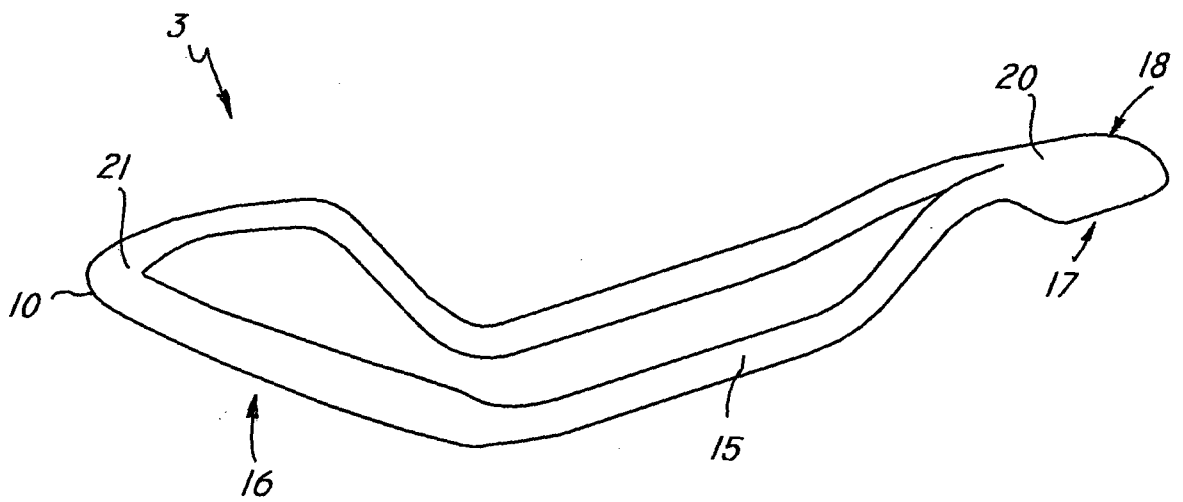
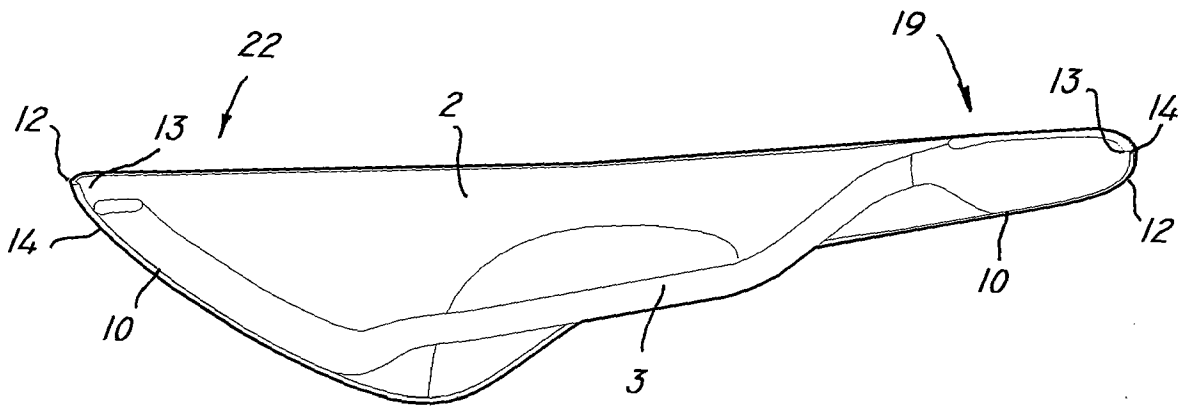
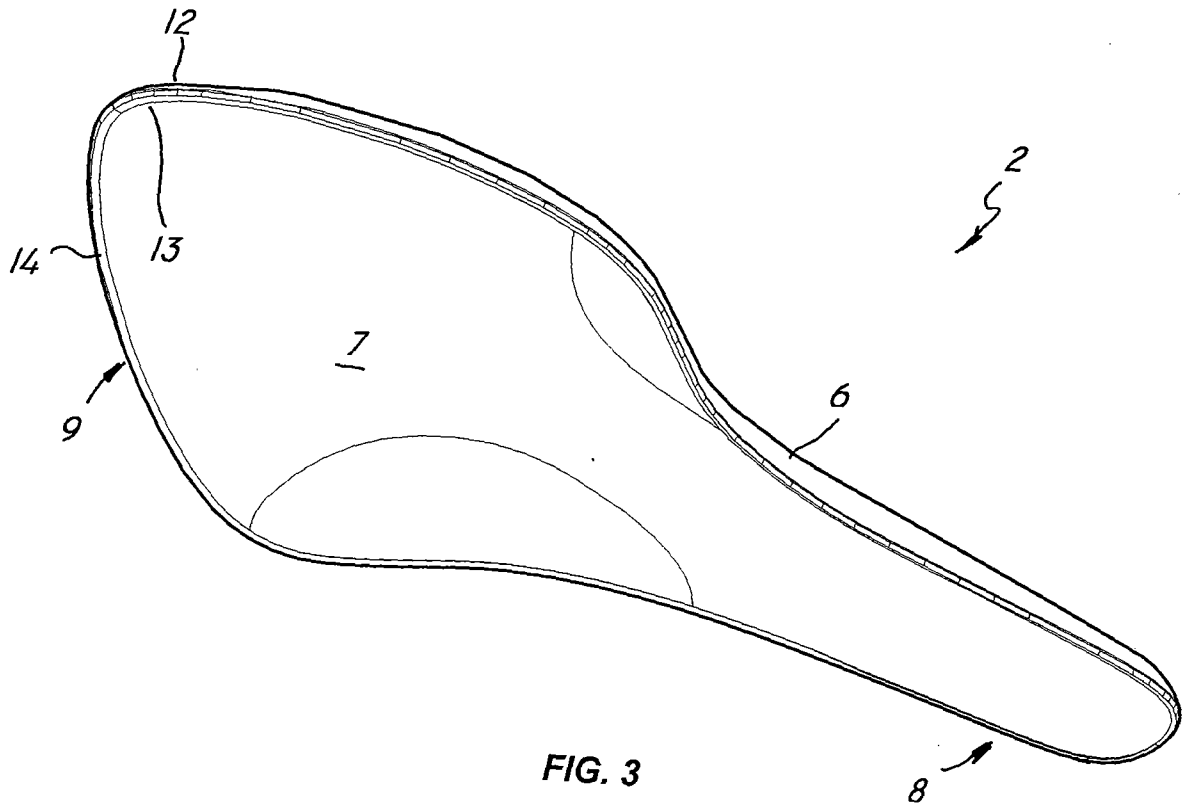
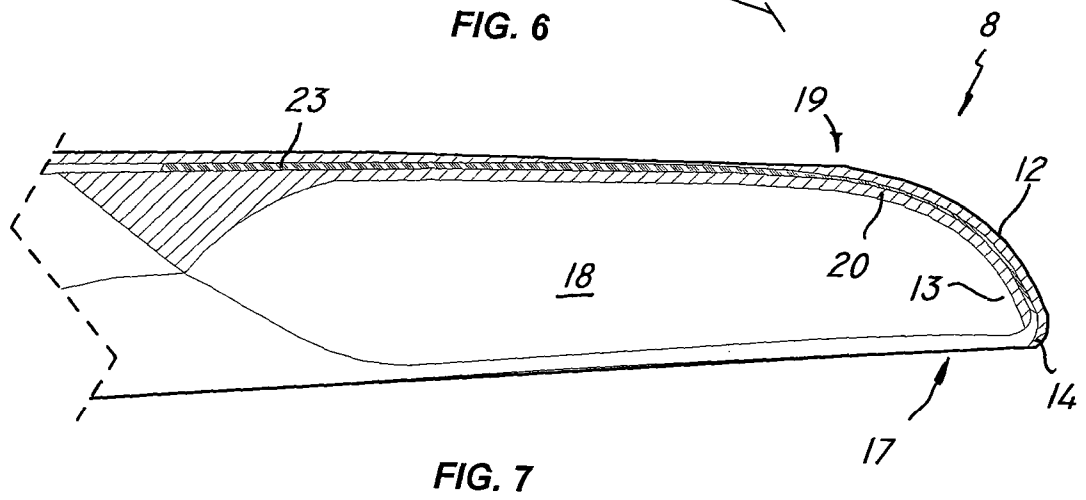
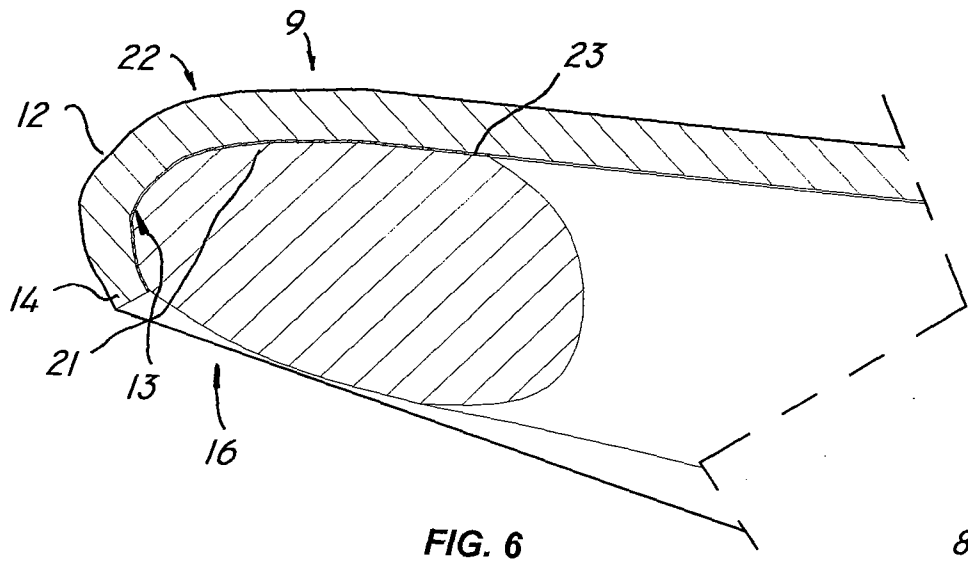
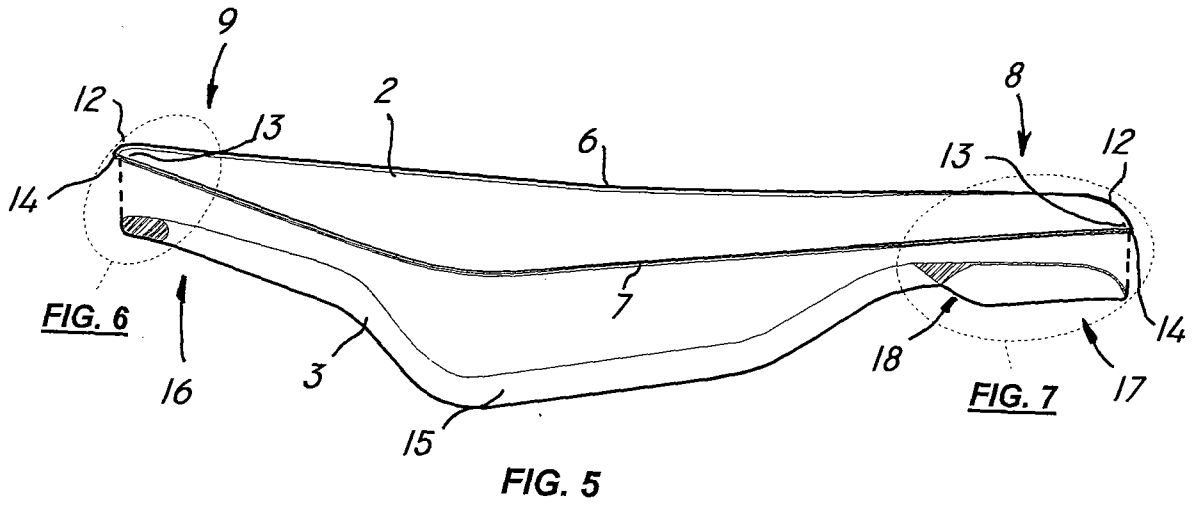

FIG. 2





INTERNATIONAL SEARCH REPORT

International application No
PCT/IB2006/054556A. CLASSIFICATION OF SUBJECT MATTER
INV. B62J1/00

According to International Patent Classification (IPC) or to both national classification and IPC

B. FIELDS SEARCHED

Minimum documentation searched (classification system followed by classification symbols)
B62J

Documentation searched other than minimum documentation to the extent that such documents are included in the fields searched

Electronic data base consulted during the international search (name of data base and, where practical, search terms used)

EPO-Internal, WPI Data

C. DOCUMENTS CONSIDERED TO BE RELEVANT

| Category* | Citation of document, with indication, where appropriate, of the relevant passages | Relevant to claim No. |
|-----------|---|-------------------------------|
| X Y | US 2004/004375 A1 (GARLAND TYLOR [US] ET AL) 8 January 2004 (2004-01-08) paragraph [0094] - paragraph [0096]; figures | 1-4, 6-9, 11-18 10 |
| X | WO 94/25331 A (CAMPBELL RAYMOND D [CA]) 10 November 1994 (1994-11-10) page 11, line 30 - page 12, line 25; figures | 1-5, 13, 14, 16, 17, 19 |
| X | US 5 927 802 A (KESINGER DONALD A [US]) 27 July 1999 (1999-07-27) claims; figures | 1, 2 |
| X | FR 2 513 586 A (PERACHE SELPE EXPL ETS [FR]) 1 April 1983 (1983-04-01) claims; figures | 1, 2, 6 |
| | ----- -/-- ----- | |

 Further documents are listed in the continuation of Box C. See patent family annex.

* Special categories of cited documents :

- *A* document defining the general state of the art which is not considered to be of particular relevance
- *E* earlier document but published on or after the international filing date
- *L* document which may throw doubts on priority claim(s) or which is cited to establish the publication date of another citation or other special reason (as specified)
- *O* document referring to an oral disclosure, use, exhibition or other means
- *P* document published prior to the international filing date but later than the priority date claimed

- *T* later document published after the international filing date or priority date and not in conflict with the application but cited to understand the principle or theory underlying the invention
- *X* document of particular relevance; the claimed invention cannot be considered novel or cannot be considered to involve an inventive step when the document is taken alone
- *Y* document of particular relevance; the claimed invention cannot be considered to involve an inventive step when the document is combined with one or more other such documents, such combination being obvious to a person skilled in the art.
- * & * document member of the same patent family

Date of the actual completion of the international search

4 May 2007

Date of mailing of the international search report

16/05/2007

Name and mailing address of the ISA/

European Patent Office, P.B. 5818 Patentlaan 2
NL - 2280 HV Rijswijk
Tel. (+31-70) 340-2040, Tx. 31 651 epo nl,
Fax: (+31-70) 340-3016

Authorized officer

Grunfeld, Michael

INTERNATIONAL SEARCH REPORT

International application No

PCT/IB2006/054556

C(Continuation). DOCUMENTS CONSIDERED TO BE RELEVANT

| Category* | Citation of document, with indication, where appropriate, of the relevant passages | Relevant to claim No. |
|-----------|--|-----------------------|
| X | EP 0 030 523 A2 (CINELLI SPA [IT]) | 1 |
| Y | 17 June 1981 (1981-06-17) page 5, line 30 - page 6, line 4; figures ----- | 10 |

INTERNATIONAL SEARCH REPORT

Information on patent family members

International application No

PCT/IB2006/054556

| Patent document cited in search report | Publication date | Publication date | Patent family member(s) | Publication date |
|--|------------------|------------------|---|--|
| US 2004004375 | A1 | 08-01-2004 | NONE | |
| WO 9425331 | A | 10-11-1994 | AU 6533294 A CA 2095055 A1 | 21-11-1994 29-10-1994 |
| US 5927802 | A | 27-07-1999 | NONE | |
| FR 2513586 | A | 01-04-1983 | NONE | |
| EP 0030523 | A2 | 17-06-1981 | DE 3069085 D1 JP 57000958 A MX 150809 A US 4367896 A | 04-10-1984 06-01-1982 23-07-1984 11-01-1983 |