

(19) World Intellectual Property Organization
International Bureau



(43) International Publication Date
12 April 2007 (12.04.2007)

PCT

(10) International Publication Number
WO 2007/041022 A2

(51) International Patent Classification:
G06Q 30/00 (2006.01)

(74) Agents: KASLOW, Kenneth et al.; Carr & Ferrell LLP,
2200 Geng Road, Palo Alto, California 94303 (US).

(21) International Application Number:
PCT/US2006/036958

(81) Designated States (unless otherwise indicated, for every kind of national protection available): AE, AG, AL, AM, AT, AU, AZ, BA, BB, BG, BR, BW, BY, BZ, CA, CH, CN, CO, CR, CU, CZ, DE, DK, DM, DZ, EC, EE, EG, ES, FI, GB, GD, GE, GH, GM, HN, HR, HU, ID, IL, IN, IS, JP, KE, KG, KM, KN, KP, KR, KZ, LA, LC, LK, LR, LS, LT, LU, LV, LY, MA, MD, MG, MK, MN, MW, MX, MY, MZ, NA, NG, NI, NO, NZ, OM, PG, PH, PL, PT, RO, RS, RU, SC, SD, SE, SG, SK, SL, SM, SV, SY, TJ, TM, TN, TR, TT, TZ, UA, UG, US, UZ, VC, VN, ZA, ZM, ZW.

(22) International Filing Date:
22 September 2006 (22.09.2006)

(25) Filing Language: English

(26) Publication Language: English

(30) Priority Data:
11/240,655 30 September 2005 (30.09.2005) US

(84) Designated States (unless otherwise indicated, for every kind of regional protection available): ARIPO (BW, GH, GM, KE, LS, MW, MZ, NA, SD, SL, SZ, TZ, UG, ZM, ZW), Eurasian (AM, AZ, BY, KG, KZ, MD, RU, TJ, TM), European (AT, BE, BG, CH, CY, CZ, DE, DK, EE, ES, FI, FR, GB, GR, HU, IE, IS, IT, LT, LU, LV, MC, NL, PL, PT, RO, SE, SI, SK, TR), OAPI (BF, BJ, CF, CG, CI, CM, GA, GN, GQ, GW, ML, MR, NE, SN, TD, TG).

(71) Applicant (for all designated States except US): SONY
COMPUTER ENTERTAINMENT AMERICA INC.
[US/US]; 919 East Hillsdale Boulevard, Second Floor,
Foster City, California 94404-2175 (US).

(72) Inventors; and

(75) Inventors/Applicants (for US only): VAN DATTA, Glen
[US/US]; 919 East Hillsdale Boulevard, Second Floor, Foster
City, California 94404-2175 (US). ZALEWSKI, Gary
[US/US]; 919 East Hillsdale Boulevard, Second Floor, Foster
City, California 94404-2175 (US).

Published:

— without international search report and to be republished upon receipt of that report

For two-letter codes and other abbreviations, refer to the "Guidance Notes on Codes and Abbreviations" appearing at the beginning of each regular issue of the PCT Gazette.

(54) Title: TARGETED ADVERTISING

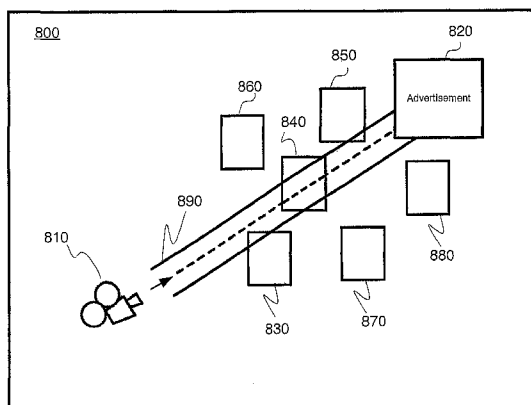

(57) Abstract: A targeted in-game advertising system is provided where advertising content may be delivered to a video game network environment. Advertisements may be delivered through the tagging of advertising assets in the video game environment according to one or more characteristics including user geographical location, personal preferences, a personal profile, video game preferences or video game genre. Methodologies for tracking advertising impressions are also provided based on monitoring the video game environment to determine the quality of impression to which the user is exposed in the video game environment.

WO 2007/041022 A2

TARGETED ADVERTISING

CROSS-REFERENCE TO RELATED APPLICATIONS

[0001] The present application is related to United States patent application number 09/780,995 filed February 9, 2001 and entitled "In-Contents Advertising Method, In-Content Advertising Server, and Program-Transferring Medium for Realizing In-Contents Advertising," which claims the priority benefit of Japanese patent application number 2000-241861 filed July 4, 2000 and Japanese patent application number 2000-375096 filed December 8, 2000. The present application is also related to U.S. patent application number 10/268,495 filed October 9, 2002 and entitled "System and Method for Camera Navigation," which claims the priority benefit of U.S. provisional patent application number 60/328,488 filed October 10, 2001. This application is further related to U.S. patent application number 11/____,____ filed September 30, 2005 and entitled "Advertisement Impression Determination." The disclosure of all the aforementioned applications is incorporated by reference.

BACKGROUND OF THE INVENTION

Field of the Invention

[0002] The present invention generally relates to targeted advertising, such as an advertising system and method for dynamically displaying advertisements in the context of video games (*i.e.*, in-game advertising). More specifically, the present invention provides for the determination and tracking of advertising impressions in response to users interacting with video games having in-game advertising functionality.

Description of the Related Art

[0003] One of the many ways the advertising industry governs the success of advertising campaigns is through impressions. Impressions refer to the exposure a user has to an advertisement or an advertising campaign. Impressions are typically indexed by the number of times a potential consumer views a particular advertisement. For example, a print advertisement located in a kiosk in a shopping center might be viewed by 1,000 shoppers over the course of an afternoon. It could be said that the particular advertisement enjoyed 1,000 impressions as each shopper walked past the kiosk and viewed the goods or services advertised therein.

[0004] High-traffic areas offer the opportunity for additional impressions. For example, an advertising kiosk located near the entrance of a popular store in a shopping center might enjoy 10,000 impressions due to high shopper traffic whereas an advertising kiosk located near an unsuccessful store (*e.g.*, a store going out of business) may enjoy significantly less advertising impressions. As advertisers seek to have their goods and services viewed by as many persons as possible, there is obviously a demand for advertisement placement in high traffic areas.

[0005] The same theory applies to other advertising media. For example, newspapers and magazines with high circulation enjoy increased advertising revenue because those newspapers and magazines offer the possibility for additional impressions whereas an unpopular or unsuccessful newspaper or magazine as do those publications circulated in small towns or with niche (*i.e.*, limited) readership. An advertisement on a billboard in Times Square in New York City will similarly offer more impressions (and demand higher revenue) than a billboard located adjacent a service road in rural Nebraska.

[0006] High traffic areas or high impression opportunities thus become a valuable asset in the advertising community. Assigning value to those assets offers a challenge as it is difficult to accurately measure how many impressions a particular advertisement or advertising opportunity might offer.

[0007] For example, television relies on the Nielsen TV ratings system whereby an estimate of the number of people watching any particular television program at any particular time is provided. Based on statistical information provided by these

ratings, a determination of which programs are the most watched or the most popular can be made. These programs often demand higher advertising fees as the increased popularity offers the opportunity for additional impressions. For example, the Super Bowl is one of the most watched television events; Super Bowl XVI between the San Francisco 49ers and the Cincinnati Bengals in 1982 saw almost 50% of the televisions in the United States 'tuned-in' to the game. As such, advertising 'spots' for the Super Bowl commonly demand exorbitant costs; a 30-second spot for Super Bowl XXXIV between the St. Louis Rams and the Tennessee Titans in 2000 demanded close to \$2M. A similar supply-and-demand theory applies to regularly scheduled programs (*e.g.*, sitcoms). Popular television shows will demand more advertising dollars due to the increased opportunity for advertising impressions whereas less popular shows will demand considerably less.

[0008] Other methodologies exist for measuring advertising impressions. For example, and as previously noted, television and magazines traditionally look to circulation to determine advertising rates whereas physical real-estate (*e.g.*, bill boards) will look at a number of factors including location, size of the bill board and general traffic in the area. Radio and the audio media have similar ratings services, for example, those offered by Arbitron Inc., in conjunction with comScore Media Metrix.

[0009] Certain advertising models have significant shortcomings. For example, pop-up Internet advertisements that appear in a Web browser are generally viewed as annoying and while usually gaining the attention of the individual 'surfing' the web, also garner their disdain for the interruption of their browsing session often leading to immediately closure of the pop-up window or, as is often the case today, the use of a pop-up blocker whereby pop-up advertisements are prevented from popping-up altogether.

[0010] Other technological innovations continue to offer additional advertising challenges. For example, digital video recorders (DVR) like those offered by TiVo® provide the ability to 'skip' over advertisements by fast forwarding through the advertisement. Due to the digital nature of the television program stored on a TiVo®

DVR, 'skipping' over advertisements is simple and does not involve the jerkiness, fast-forward/back-up that accompanied VHS tape recorders and video tapes.

[0011] The advertising industry is, therefore, increasingly faced with the inability to target its advertisements to individuals due to the decrease in readership in print media, unrefined advertising methodologies on the Internet and the inability to keep audiences 'captive' whereby there is a certain degree of assurance that a consumer views a particular advertisement (*e.g.*, users can now 'skip' over ads while remaining in front of their television during a television program).

[0012] The video game industry is quickly becoming one of the last bastions of captive audience advertising. That is, the player of a video game often offers their undivided attention to the video game environment so that they may remain aware of actions taking place in the game (*e.g.*, being attacked by an enemy, discovering a cache of weapons or treasure trove, identifying a 'lane' through which to navigate a running back in a football game). Video games, therefore, offer the opportunity for placing ads before a captive and extremely attentive audience.

[0013] There have been—and continue to be— numerous cases wherein actual advertisements of advertisers are deployed and displayed within a video game environment. A classic example is in a driving game, wherein advertisements are pasted onto billboards around a driving course as illustrated in U.S. patent numbers 5,946,664 and 6,539,544, the disclosures of which are incorporated herein by reference. With such in-game advertising, the software publishing company that creates the video game identifies an advertiser, creates texture data based on ad copy provided by the advertiser and places this texture data representative of an advertisement in the video game environment (*i.e.*, posting the advertisement on the billboard).

[0014] Online and networked gaming is increasing in popularity throughout the world. With this increase in popularity, there is an expectation that gaming networks assemble standards and evolve into an advertising channel such as television and radio. As a part of this increase and evolution, there is a need for a framework and system for advertisers and media providers to manage and track advertising in video games and other digital environments.

SUMMARY OF THE INVENTION

[0015] The present invention may be configured to provide a system and method for deploying and tracking advertisements across a video game network.

[0016] The present invention may be configured to provide for the identification of tagged advertising assets in a video game environment and delivering advertising content for rendering in those assets; ad impressions are then counted in response to user movement and user exposure to the advertisements.

[0017] The present invention may be further configured to provide for the delivery of targeted advertising content in a video game environment where the targeted advertising content is associated with a user characteristic.

[0018] The present invention may be configured to provide for identifying user characteristics from a user profile or from third-party information.

[0019] The present invention also be configured to provide for the delivery of targeted advertising content in a video game environment where the targeted advertising content is associated with the video game environment.

[0020] The present invention may be configured to provide for processing a payment associated with the rendering of an advertisement in the video game environment.

[0021] The present invention may be configured to provide a system for delivering and tracking advertising content in a video game environment whereby an end-user client device calculates advertising impressions, the advertising content having been delivered by an advertising server.

[0022] The present invention may be further configured to provide a machine readable medium configured to perform a method of identifying advertising assets in a video game environment, delivering advertising content to those advertising assets and counting user exposures to those advertising assets.

[0023] The present invention may also be configured to allow advertisers to identify popular games and/or effective advertisements to allow for the establishment of proper pricing models, receive feedback on their products, market

to various segments and deploy custom programming relating to advertising campaigns in an adaptable in-game advertising network.

BRIEF DESCRIPTION OF THE DRAWINGS

- [0024] FIGURE 1 illustrates an exemplary in-game advertising system as may be utilized in an embodiment of the present invention;
- [0025] FIGURE 2 illustrates an exemplary flow of communication between members of the in-game advertising system as illustrated in FIGURE 1;
- [0026] FIGURES 3A and 3B illustrate the exemplary tagging of assets in a video game environment;
- [0027] FIGURE 4 illustrates exemplary advertising structure information as may be used in an embodiment of the present invention;
- [0028] FIGURE 5 illustrates an exemplary end-user client device as may be used in an embodiment of the in-game advertising system of FIGURE 1;
- [0029] FIGURE 6 illustrates an exemplary method of in-game advertising upon activation of game program comprising tagged assets for advertising;
- [0030] FIGURE 7 illustrates an exemplary advertisement output method when game data is provided to a video game client device;
- [0031] FIGURE 8 illustrates line-of-sight obstacles as may be found in a video game environment, in one embodiment in accordance with the present invention ;
- [0032] FIGURE 9 illustrates a positional relationship between a game character and an advertisement, in one embodiment in accordance with the present invention;
- [0033] FIGURE 10 illustrates a second positional relationship between a game character and an advertisement, in one embodiment in accordance with the present invention;
- [0034] FIGURES 11A and 11B illustrate two positional relationships between a game character and an advertisement relative obstacles in an impression area, in one embodiment in accordance with the present invention;
- [0035] FIGURE 12 illustrates an exemplary line-of-sight determination methodology to be used in determining the occurrence of an advertising impression, in one embodiment in accordance with the present invention;

[0036] FIGURES 13A-13B illustrates the correlation between an impression counter and a positional relationship of a game character and an advertisement, in one embodiment in accordance with the present invention; and

[0037] FIGURE 14 illustrates an alternative correlation between an impression counter and a positional relationship of a game character and an advertisement, in one embodiment in accordance with the present invention.

DETAILED DESCRIPTION OF AN EXEMPLARY EMBODIMENT

[0038] FIGURE 1 illustrates an exemplary in-game advertising system 100 as may be utilized in an embodiment of the present invention. The in-game advertising system 100 of FIGURE 1 comprises a network 110. Network 110 may be, for example, a cable television network, a broadband wireless network or on optical fiber network. The present invention does not impose any limitation with regard to the particular type of communication medium(s), whether the network is homogeneous (*e.g.*, end-to-end wireless) or whether the network is proprietary, open or a combination of the two. Network 110 only need provide the means to communicate amongst the various servers and/or terminals coupled to the network 110 and make up the advertising system 100 of an embodiment of the present invention. Network 110 may be a communications network, a data network or a combination of the two.

[0039] As shown in FIGURE 1, communicatively coupled to the network 110 is a content server 120 as offered by a content provider 120; an advertising server 130 as offered by an advertising agency, the server comprising or coupled to an advertising database 140, the advertising database 140 comprising advertisement information data. The exemplary system 100 illustrated in FIGURE 1 further comprises content authors 150₁ . . . 150_N; advertisers 160₁ . . . 160_N; and end-user client devices 170₁ . . . 170_N. Some embodiments of the present system may further comprise a payment processing center 180 and an advertising content creator 190.

[0040] The content server 120 may distribute digital content. Content may be request from networked devices operating in a gaming network. In one embodiment, the content is requested by end-user client devices 170₁ . . . 170_N. The content distributed by content server 120 may comprise video game content (*e.g.*, actual video games, or portions thereof, accessed by end-user client devices 170₁ . . . 170_N) as well as other forms of digital media (*e.g.*, music and video). The content server 120 may further provide for the storage of digital content. The content server 120 may store such content locally (*e.g.*, as part of a storage area network) or at a location physically remote from the content server 120 but otherwise

communicatively coupled to the server 120 thereby allowing for retrieval and transmission of the content to end-user client devices 170₁ . . . 170_N. Content served by the content server 120 may be served as the result of a push or pull operation.

[0041] The advertising server 130, as previously noted, may be managed by an advertising agency providing for the distribution of advertising content to larger audiences (*e.g.*, end-users). The advertising server 130 may serve audio, video, audio/video and still image content. Content served by the advertising server 130 may be served as the result of a push or pull transaction. Advertising database is a storage mechanism for advertising content such as the aforementioned video and audio content. While advertising images are the most prevalent type of advertising content, advertising content may further comprise element types such as programs, objects, state data, control data, textures, bitmap images, compressed images, sequencing data, authentication data, public key and private key. Advertising database 140 may be integrated with advertising server 130 or may be physically remote from the advertising server but otherwise providing a communicate coupling allowing for the retrieval of content from the database 140 for subsequent transmission to end-user client devices 170₁ . . . 170_N.

[0042] Content authors 150₁ . . . 150_N are those entities that develop content for distribution to end-users, for example, video games. Content authors 150₁ . . . 150_N may also develop audio, video and/or audio/video content. Content developed by content authors 150₁ . . . 150_N may be generated in any form of media. For example, content may be developed in an optical disk format or in non-volatile memory such as a flash card. Content may also be provided in a pure data format to be transmitted and hosted by another party. For example, content author 150₁ . . . 150_N may develop a video game but never commercially distribute the content in a physical form of media. Instead, the content may be FTP'd or otherwise transmitted to content server 120 and stored in an appropriate storage means for subsequent delivery to end-user client devices 170₁ . . . 170_N.

[0043] Advertiser 160₁ . . . 160_N is any entity seeking to place an advertisement in the digital content created by content author 150₁ . . . 150_N. Advertiser may be from

any field of endeavor and need not necessarily be in the entertainment or video game industry.

[0044] End-user client devices 170₁ . . . 170_N are those devices allowing an end-user to access digital content. For example, in the case of a video game, the appropriate end-user client device 170₁ . . . 170_N may be a home entertainment video game system such as a PlayStation3 from Sony Computer Entertainment Inc. In the instance of digital content being, for example, an on-demand movie or other video program, the end-user client device 170₁ . . . 170_N may be a set-top cable box. End-user client device 170₁ . . . 170_N may, in other instances, be a portable device that may be temporarily coupled to a more permanent device (*e.g.*, a desktop computer) to allow for the transfer or updating of digital content via a USB cable as would be the case in, for example, a portable music device such as an MP3 player.

[0045] Optional payment processing center 180 allows for the execution of various payment and/or monetary transfer transactions. These payments may be achieved, for example, through direct deposit, automatic funds or wire transfers as is appropriate and/or available. Payment processing center 180 may, for example, be a bank offering these services. In another example, payment processing center 180 may be an on-line escrow agent communicatively coupled to a variety of banks wherein the escrow agent instructs and/or receives notice of various monetary transactions on behalf of various entities in the exemplary in-game advertising system 100 (*e.g.*, advertisers 160₁ . . . 160_N and content providers authors 150₁ . . . 150_N).

[0046] Advertising content creator 190 is an entity that authors and/or develops advertisements on behalf of advertisers 160₁ . . . 160_N for placement into digital content. In some instances, advertising content creator 190 may only digitally author content. For example, certain advertising copy (be it audio, video, print or any combination of the three) may have already been created in a non-digital format. In those instances, advertising content creator 190 would manipulate (*e.g.*, digitize) the advertising copy so that it may be placed into the greater context of digital content that is offered by the content server 120. In other instances, advertising content creator may take a script for an advertisement and create the same (*e.g.*, film video,

record audio and then combine the two with various special effects). Advertising content creator 190 may also utilize program objects and program scripts including commands related to special effects, program elements, control signals, messaging and various protocols. In still other instances, advertising content creator may develop advertisement campaigns from scratch (*e.g.*, the advertising concept for a campaign) and subsequently create the ad content to correspond to that campaign.

[0047] FIGURE 2 illustrates an exemplary flow of communication 200 between members of an exemplary in-game advertising system 100. The content author 150₁ . . . 150_N provides the advertising server 130 with advertisement structure information in step 205. The content and makeup of advertisement structure information is discussed in the context of FIGURE 4. The advertisement structure information is registered in the advertising database 140 of the advertisement server 130. The operator of the advertisement server 130 informs the advertiser 160₁ . . . 160_N of advertisement information such as title, contents, etc., of a newly-registered title in informing step 210. Informing of the advertiser 160₁ . . . 160_N may occur by traditional mail, electronic mail, listservs, SMS, instant messenger, chat or any other available communication medium.

[0048] The advertiser 160₁ . . . 160_N can access the advertisement server 130 and can view the advertisement information in viewing step 215 and further apply for an advertisement buy from, for example, a web-browser screen in application step 220. Once the advertisers 160₁ . . . 160_N have been established, advertiser specified information such as advertiser name, time slot, and time period of an advertisement are provided to an appropriate content author 150₁ . . . 150_N from the advertisement server 130 in notification step 225. Notification may occur by traditional mail, electronic mail, listservs, SMS, instant messenger, chat or any other available communication medium.

[0049] Advertiser specified information and advertisement structure information are also supplied to the advertisement content creator 190 via the advertisement server 130 in ordering step 230. The advertisement content creator 190 creates advertisement content (*e.g.*, the advertisement) based on the advertiser specified information and advertisement structure information. The completed advertisement

information such as bitmap data or other graphic, audio and/or video data is delivered by the advertisement content creator 190 to the advertisement server 130 in delivery step 235.

[0050] Notification of the receipt of the completed advertisement is communicated by the advertisement server 130 to the advertiser 160₁ . . . 160_N in completion step 240 by traditional mail, electronic mail, listservs, SMS, instant messenger, chat or any other available communication medium.

[0051] The advertiser 160₁ . . . 160_N can view the completed advertisement information on the advertisement server 130 in viewing/approval step 245. If the advertiser 160₁ . . . 160_N approves of the completed advertisement content (*e.g.*, by pressing an 'OK' button in a web-interface), the advertisement content is confirmed and an itinerary is by the advertisement server 130 to the content author 250 by traditional mail, electronic mail, listservs, SMS, instant messenger, chat or any other available communication medium in delivery detail confirmation step 250. The itinerary delivered in step 250 may comprise information related to the advertiser, time slot, period, advertising fees and so forth.

[0052] In registration step 255, the content provider 120 correlates certain advertisement information and advertisement content with digital contents to be delivered. That is, the content provider 120 recognizes that particular advertisements are to be delivered with particular portions of digital content and so forth. This correlation of information may comprise authoring new derivative files reflecting both advertisement information and digital content/advertising programs), the embedding of metadata in the digital contents or the implementation of object oriented programming wherein certain data files (*e.g.*, digital contents/advertising programs) call upon other distinct files (*e.g.*, advertising information). The metadata may also comprise information as it pertains to advertising information such as how long a game character must be present within an impression area defined within the video game. The metadata may further provide information defining the parameters of the impression area and certain quality factors as are discussed herein. Tracking parameters and feedback information and/or instructions may further be imbedded in the metadata of the advertisement. Such information may also be

contemporaneously downloaded with the advertising information as a separate file whereby the advertising information calls upon certain information related to impressions, reporting and so forth.

[0053] A user accesses and/or requests digital content (*e.g.*, a driving simulation video game) using end-user client devices 170₁ . . . 170_N in content application step 260. As a result of the application for content, the user may start to download the content in download step 265. Alternatively, if the user already has a particular portion of the digital content, this step may involve presenting the user with an update as to that content. This step may also comprise unlocking digital content that is already in possession of the user. Step 265 may also involve authenticating removable media, accommodating registration with a game network or a game 'lobby' or 'waiting room' and so forth

[0054] In some embodiments of the present invention, the user may access digital content using permanent physical media (*e.g.*, an optical disc). The physical media may have embodied thereon instruction for accessing the present in-game advertising system 100 as it pertains specifically to advertising content versus actual video game data. In additional embodiments of the present invention, the user may access a combination of advertising content and actual game data via the exemplary in-game system 100 (*e.g.*, new advertising content and new game levels published after the initial release of the game on physical media). Such embodiments are discussed in further detail below.

[0055] During the download of content and/or advertisements in step 265, the content provider 120 notifies the advertisement server 130 of the download request as it relates to particular advertising material in step 270, such correlations between content and advertising having previously been made in registration step 255. The advertisement server 130 then transmits the necessary advertisement data corresponding to the user download to the content provider 120 in step 275. If necessary, the advertising data provided to content provider 120 can be updated over time relative the content being downloaded (*e.g.*, new ad copy).

[0056] After downloading the digital contents (including advertisement information or content in ad information delivery step 275), the user (through end-

user client device 170) renders the advertisement information within the game contents, the advertisement information having been provided via advertisement server 130. As noted above, some embodiments of the present invention may access solely advertising information or a combination of new game content and advertising information rather than an entire game.

[0057] The state of the advertisement, such as the number of distributions or impressions made, may be provided to the advertisement server 130 and, if necessary or desired, to the advertiser 160₁ . . . 160_N in advertisement status notification step 280 so that certain determinations may be made, for example, the success of an ad campaign with regard to the number of impressions made.

[0058] As a result of the notification in step 270, the advertisement server 130 can track the advertisements that have been or are being downloaded to an end-user client device 170. Utilizing certain ad impression and tracking methodologies as discussed herein, the advertisement server 130 can receive feedback in connection with advertisement impressions. Information concerning impressions or other advertisement feedback may be generated at the end-user client device 170, which has been configured with the necessary software to either directly or indirectly implement impression tracking.

[0059] Direct impression tracking may be based on software configured at the end-user client device 170 and that operates in conjunction with a game kernel and is further configured to participate in network communications such that textures and objects or indexes to textures and objects related to an advertising campaign may be received. The tracking software may directly monitor the angle and position of various advertising asserts with respect to changing camera perspectives presented to the user who controls the camera perspective utilizing a game controller. Indirect impression tracking may occur through a server or a session master client in a peer-to-peer network participating, facilitating, arbitrating or interrogating functions associated with the campaign program (e.g., extraction of data necessary to yield the determination of an ad impression). Hence, ad impression determinations may occur at, for example, ad server 130 or advertiser 160 in response to information generated or signals sent from the end-user client device 170.

[0060] Ad impression data may be batched or transmitted over the network at periodic intervals. Transmission of impression data may occur in accordance with a schedule or in conjunction with other processes or transmissions used to facilitate game play. Impression data may also be streamed or pulled during an inquiry received over the network. Any network element of the advertising system 100 may facilitate or influence the transmission of impression data.

[0061] Advertisement impressions may be calculated in various ways. For example, an advertisement located in a virtual kiosk in a virtual shopping center might be viewed by 1,000 gamers over the course of an afternoon. It could be said that the particular advertisement enjoyed 1,000 impressions as each gamer walked their gaming character past the kiosk and viewed the goods or services advertised therein. Impressions may also be calculated through a time threshold index. For example, an impression may be earned, triggered, counted or computed after a user has been exposed to the advertisement for a particular period of time. In this example, an impression may occur after 30 seconds of exposure by the user to an advertisement. The impression may also be tracked and computed based on one or more user's continuous or distributed exposures to the advertisement on the virtual kiosk or as part of an overall ad campaign.

[0062] The advertisement content receiving, impression tracking and impression data feedback transmission systems of the present invention may reside in a single software element or in multiple software elements. Software elements may be distributed in whole, or part, on one or more processors or across a local or wide area network.

Impression tracking software may be provided as a result of downloading a necessary software module during download step 265 or the software having been installed directly on physical media (*e.g.* an optical disk) read by the end-user client device 170 or, alternatively, installed directly in the end-user client device 170. Tracking software or various components of the software may also be installed in the various other components of the advertising system 100 dependent upon the particular configuration of an embodiment.

[0063] Similar or identical advertisement state information may be provided to content author 150₁ . . . 150_N. This notification is made so that the advertiser 160₁ . . . 160_N may be properly invoiced by the contents author 150₁ . . . 150_N in accordance with any number of payment plans as are discussed herein. The advertisement server 130 may further provide this information to payment processing center 180 to allow for automatic billing and payment in step 285. These payments may be achieved, for example, through direct deposit, automatic funds or wire transfers or any other money transfer methodology as is appropriate and/or available.

[0064] The advertising system 100 and methodology of the present invention and as described in an exemplary embodiment through FIGURES 1 and 2 may be implemented over various communication and data networks.

[0065] It should be noted that in some embodiments of the present invention, certain elements of the in-game advertising system 100 may be combined or removed from the system 100 entirely without compromising the operations of the system 100. For example, an embodiment of the in-game advertising system 100 as described herein may function without the need for a payment processing center 180 as proper remuneration of parties in the system 100 may have been established before hand or subject to analysis of certain information after advertisement delivery. Similarly, the ad server 130 and related database 140 may be operated in conjunction with the advertisement content creator 190 or with content provider 120. Various approval and notification steps may also be omitted in the course of FIGURE 2 so long as ad buys remain reserved, as is discussed in the context of tagging in FIGURE 3, and the proper advertisements delivered relative those tagged assets. Additionally, exchanges of data or various notifications described above may be of a dual-direction or exchanged between various components of system 100. For example, various notifications may be delivered to the ad server 130 in addition by the ad server 130. In that regard, the present invention is not meant to be limited by the exemplary data flows as depicted in FIGURE 2 of the present invention.

[0066] While FIGURES 1 and 2 illustrate an in-game advertising system 100 wherein content and advertising were both provided to an end-user client device 170 over network 110, in some embodiments, a user may play game as embodied on a

physical media such as an optical disk as may be utilized in, for example, a PlayStation3 gaming console or for use in a desktop computer (*e.g.*, to be inserted into a CD-ROM drive). In these instances, various libraries related to the game (*e.g.*, character generation, user interfaces, recognition of user controls and so forth) may be authored and stamped directly onto the physical media instead of accessed or downloaded via content provider 120.

[0067] In such an embodiment, advertising content may be embodied on the physical media as well. As has been previously noted, however, such advertising schemes may be ineffective if the popularity of a game turns out to be overrated (wherein an ad buy was likely overpriced) or underrated (wherein an ad buy was likely under priced). Similarly, the relevance of certain advertisements may expire over the course of time (*e.g.*, an advertised event occurs, the advertiser stops selling the product or goes out of business or the advertisements are mock advertisements pertaining to a fictitious product but remain relevant in the context of the game despite the passage of time).

[0068] In such physical media, a software client may be embodied in the physical media, the client comprising the operating routines, resources, instructions and so forth that allow an end-user client device 170 reading the optical media or other physical media to access the in-game advertising system 100 like that described in the present invention. Although the user may not necessarily be receiving video game content (*e.g.*, the user does not download or directly access code and other information related to the actual game), the user may still receive advertising content as the client pertains to the instructions and operations necessary to access in-game advertising system 100 and for advertising content to be provided to the system 100.

[0069] Through the provision of such an advertising client on physical media, it becomes possible for a variety of parties that develop games that operate on a particular end-user client device (*e.g.*, the PS3 game console) to interact with the in-game advertising system 100. Access to the advertising client code may be subject to a fee charged by the in-game advertising system 100 operator, the costs of which may be recouped by the third-party game developer who passes those costs onto

advertisers 160₁ . . . 160_N that might wish to place content in a particular video game as the popularity and advertising value of that game is assessed.

[0070] In order to enjoy the advertising opportunities offered by such a system like that described in the present invention, certain objects in a video game may be 'tagged' as subject to advertising. For example, and as shown in FIGURE 3A, the face of a billboard 300 may be 'tagged' 310 to indicate that an advertisement may be embedded in that location. In this way, the in-game advertising system 100, via the advertising client embodied in video game software, may identify these tagged assets and provide advertising content that may be imposed through texturing or other graphic rendering techniques that make it appear as if the advertisement was designed specifically for the billboard as shown FIGURE 3B (320). Such advertising content may be pushed or pulled to the video game environment at an end-user client device 170 via the advertising server 130.

[0071] Alternatively, advertising content may be loaded into a game during development and specific advertising campaigns may be purchased after the release of the game. In such an embodiment, advertisement purchases trigger signaling event that index specific ads embedded in a game and unlock the advertisements. The ads are then associated with one or more tagged advertising assets. Preloaded advertisements may be replaceable in whole or in part over the network by a server or via a peer-to-peer arrangement. The replacement of advertisements may occur based upon a user profile, user interaction with an advertisement or ad campaign, geographic location of the user or control signals, messages or communication in connection with the advertisement.

[0072] Tags reflect not only the space where an advertisement may be placed but may also reflect information such as size limitations, coloring and shading requirements, pointers to variables that track state and impression data, functions and programs associated with the advertisement, hyperlinks and mini-games associated with the advertisement, user-profile filters and, in some embodiments, even advertising relevance. It should be noted that the said functions and programs associated with the advertisement may access variables that track state and impression data. Tags may be numbered to reflect individual assets wherein

advertisements may be imposed or grouped to reflect that one particular advertiser 160₁ . . . 160_N should have one or more of their advertisements placed in these tagged groups (*e.g.*, all billboards on a city block). The tagging of assets and rules related to the tagging of assets may be imposed by content author 150. Rules embedded in the tagged assets (*e.g.*, ad size) may be recognized by advertisement server 130 to ensure that the proper advertising content is delivered to these tagged areas when called upon in the in-game advertising network 100.

[0073] Impressions of or exposure to advertising asset tags are capable of being tracked independently or as a group. Additionally, impressions of or exposure to advertising asset tags are capable of being aggregated against a particular end-user device, versus a particular game or across a network in general. For example, an advertising server 130 may receive ad impression information relating to impressions of specifically tagged assets (*e.g.*, billboard A, billboard B, billboard C, etc.) or assets as they apply to a particular advertiser (*e.g.*, Coke, Pepsi or Sprite) at an end-user device or a plurality of devices. Impressions and exposure may also be aggregated as they pertain to a particular game whereby the number of impressions generated for a particular advertiser in a particular title are determined regardless of the particular asset on which the advertisements were placed. Similar aggregation of impression data can occur across an entire network regardless of the particular game title whereby the total impressions for a particular advertiser are determined against all end-user client devices communicating with the advertising network/system 100. Other aggregation parameters may be utilized at the particular needs of an advertiser.

[0074] Tagging is not limited to 'print-like' advertisements (*e.g.*, a billboard). Tagging can also be related to other visual formats such as audio and video. For example, a television in a video game may be tagged as to reflect that the user tuning the television to a particular channel will cause a full motion video advertisement to be streamed. Various other advertisements could be streamed or rendered on additional channels subject to the whim of the game designer and the extent of tagging of assets for advertisement introduction.

[0075] Similarly, audio may be tagged for advertising purposes. For example, if a user plays a video game with a radio (*e.g.*, driving an automobile), the game designed can create different channels whereby actual music from actual artists is played interspersed with various advertisement that one might hear over the radio. Similarly, the actual music a user listens to may be Top 40 hits or other popular music rather than a one-time generated, static soundtrack. In that way, the user may play the game today or five years from now and be able to listen to not only relevant advertisement but relevant music that is current and popular the day the user plays the game. Similar attributes may be reserved for providing real-time television programs and the like (*e.g.*, short films, movie previews and so forth).

[0076] As a result of tagging and the delivery of relevant advertisements into the user's game environment, tracking of advertisements may take place. That is, through in-game advertising system 100, it may be determined exactly how many times a particular advertisement was introduced to an end-user client device 170 subject to any variety of conditions (*e.g.*, nationwide ad buys over the gaming network or geographic or targeted advertisements). Additionally, and as described in FIGURES 10 and 12, for example, it may be determined how many actual impressions of that advertisement occur.

[0077] It should be noted that while most networks and computing devices can provide nearly instant rendering of dynamic advertising information, to identify a particular portion of an environment where such dynamic content may be rendered (*e.g.*, identifying a tag), sending relevant information to the advertising server 130 and retrieving the relevant advertising information may take several seconds. If a user has a slow or congested communications network or a computing device with slower processing power, rendering of that dynamic information may take even longer. If extended delays in rendering information result or, worse, stagnation of game play to wait for the rendering of the dynamic advertising information, user's may lose interest in the video game or seek to deactivate the dynamic advertising aspects of the game.

[0078] As such, it is necessary for video games to identify references points in the video game environment (*e.g.*, physical points in the video game or subject to the

accomplishment of certain tasks or reaching a certain level) to determine when the in-game advertising system 100 should begin to be accessed to acquire the necessary advertising information. For example, while a user may not have yet reached a billboard tagged to render advertising information, the user may have surpassed a reference point earlier in the game such the content begins to load in the background to provide for instant rendering when the user finally does reach the billboard. An example of such dynamic loading methodology is described in U.S. patent number 6,764,403, which is incorporated herein by reference.

[0079] FIGURE 4 illustrates exemplary advertisement structure information 400 as may be utilized in an embodiment of the present invention. As illustrated in FIGURE 4, advertisement structure information 400 comprises a header 410 identifying the content author 150, movie content data 420, which may be a few frames to the entire production, game program data 430, object data 440 and multiple sets of texture data 450-460.

[0080] Certain embodiments of advertisement structure information 400 may be abbreviated, that is, it comprises demonstration or short previews of larger portions of content (namely movie content 420 and game program data 430). In other embodiments, only game program data 430 may be present, for example, for game downloads in the context of the present in-game advertising system 100. In even further embodiments, for example, wherein physical media comprises game program information, only header 410 and certain ad information may be present.

[0081] Object data 440 comprises coordinate values of information of objects in a game environment, those objects made up of polygon apex data or the like. Texture data 440-450 comprises pattern data of the object data converted from three-dimensional data to two-dimensional data through various conversion techniques known in the art. For example, object data 440 may related to a race car, texture data 450 and 460 would relate to color patterns and logo advertisements on the race car.

[0082] In an embodiment of the present invention utilizing advertisement structure information 400, advertisement information AD₁ . . . AD₄ is embedded in the structure information 400. AD₁ may comprise information such as a code indicating that advertisements may be inserted, the nature of the advertisement to be

inserted, or information pertaining to frames, resolution and so forth. This data may be linked to the advertisement server 130 whereby advertisements are inserted into a game environment. Advertisement information $AD_1 \dots AD_4$ may also be embedded in physical media should it be necessary to download content as is described in certain embodiments of the present invention.

[0083] FIGURE 5 is a block diagram illustrating an exemplary end-user client device 500 ($170_1 \dots 170_N$). End-user client device $170_1 \dots 170_N$ comprises a user terminal 510, monitor 520, main data storage 530, sub-data storage 540, controller 550, and network interface 560 that coupled the device 500 to network 110. In an entertainment system represented by a home computer, the main data storage 530 may comprise a hard disk drive or a high-speed optical disk drive or the like. Sub-data storage 540 in such an embodiment may comprise flash memory. Game data $G_1 \dots G_N$ comprise advertisement information $AD_1 \dots AD_4$ (as described in FIGURE 4) and is stored in the main data storage 530.

[0084] FIGURE 6 illustrates a method 600 of in-game advertising upon activation of game program (*e.g.*, a downloaded program or one embodied in a physical media) comprising tagged assets for advertising.

[0085] In optional step 610, a determination may be made whether a game program comprising tagged assets has been activated. Once the digital contents have been downloaded or accessed on physical media via end-user client devices $170_1 \dots 170_N$, an advertisement delivery program on advertisement server 130 may be contacted to request advertising content. If an end-user client device 170 operating a game program with tagged assets has not been activated, the server 130 can await a request or indication delivery of content is or will be necessary. If such a program has been activated, the advertising program may access the advertising server 130 in step 620 and, in step 630, make notification of the title of the digital contents activated on the end-user client device 170 user address (*e.g.*, a network address). Depending on the nature of the advertising content to be delivered (*e.g.*, targeted advertising as discussed herein), the advertisement server 130 reads out the advertisement data in advertisement database 140 and transfers this content to the user's address. In step 640, the end-user client device 170 receives the advertising

data under control of the advertising program, records this in the main data storage 530 (FIGURE 5) in step 650, and in step 660, generates a table of information indicating addresses in the main data storage for advertisement data, and the position of the advertisement target (*i.e.*, the tagged asset).

[0086] Once the game starts or action in the game continues in step 670, a determination is made in step 680 with regard to whether or not the tagged asset has been reached in the game environment; that is, has the user reached the position for inserting advertisement information. If the determination is YES, in step 690 the corresponding advertisement data is positioned at the corresponding position in the memory (*i.e.*, the tagged asset). In some embodiments, it may not be necessary for advertisements to be inserted during game play as tags may be associated with advertising content upon game commencement, upon a level change or in response to a control signal relating to an in-game advertising event.

[0087] As has been previously noted, advertising information may be dynamically loaded prior to the content being needed. Larger advertising data—for example, full motion video or audio—may be stored in main memory 530 or a graphics engine buffer (not shown) before action in the game commences. Other embodiments may place object data and/or texture data in the main memory 530 either immediately before the game action starts or before the data is used.

[0088] In FIGURE 7, an exemplary method 700 for the operation of an advertisement server 130 wherein advertising data is requested by the advertising program is illustrated. In step 710, a determination is made regarding whether or not there is access from the end-user client devices 170₁ . . . 170_N and in the event this determination yields YES, the title of the digital contents and the user address is received from the terminals end-user client devices 170₁ . . . 170_N in step 720, the advertisement database 140 is referred to in step 730 wherein advertisement data corresponding to the title of targeted advertising is read out in step 740. The advertisement data is transmitted to the end-user client devices 170₁ . . . 170_N indicated by the user address received in step 750 and a transmission record for the advertising data is created and/or updated in step 760. This record reflects the number of times an advertisement is pushed to a user and/or, depending on

feedback from the game environment, the number of impressions of that advertisement that occur whereby calculations as to payment or future valuation may be made.

[0089] The presently described in-game advertising system 100 may also be utilized to provide for the targeting of advertisements. Providing information over a communications network requires proper addressing of that information to an end-user. For example, a network address (*e.g.*, an Internet Protocol address) may be static and assigned to a particular user. Identifying the actual user assigned to this address may be achieved through the network service provider (*e.g.*, an ISP) that is assigned the network address and aware of the address of that user. Alternatively, a user may register with a content provider (*e.g.*, an on-line gaming network), which may require providing specific information (*e.g.*, name, e-mail, billing address and so forth).

[0090] In the case of acquiring end-user information from a network provider (*e.g.*, through a commercial information sharing agreement), the acquired information may reflect billing information (*i.e.*, certain geographic information). Similarly, registering with the content provider may reflect certain geographic information of the user (*e.g.*, billing information). As a result of this geographic information, an advertiser may target geographic or region-specific advertisements.

[0091] For example, an end-user that resides in Boston may have little interest in receiving information concerning New York Yankee season ticket sales. Similarly, there would likely be little value to advertise a regional product or service such as a restaurant in New York to someone who resides in San Francisco where that product or service is not offered. National advertising campaigns concerning a regional product or service would likely be ineffective relative a return on the advertising investment and may annoy the user receiving those advertisements, because the user may have no interest/access to the product or service being advertised. In contrast, a user in San Francisco might have interest in receiving advertisements related to San Francisco Giants season ticket sales or a concert in the area; that is, geographically relevant advertisements.

[0092] By acquiring geographic information of a user (either through direct registration or a service provider), advertisements can be targeted so that the appropriate advertisement is directed to the user. In this way, advertising dollars are ensured a greater return on investment. For example, products localized to Boston are advertised to persons living in the Boston area and products specific to San Francisco are advertised to persons residing in the San Francisco area.

[0093] Geographic information may also be inferred from other available information. For example, an IP address may identify a particular region of a country through geo-location. While geo-location via an IP address is not as accurate as explicit registration with a service provider, it provides a greater degree of accuracy than would blind advertisement campaigns. Thus, even dynamic IP addresses that are not consistently associated with any particular user (but instead a service provider who may recycle the address amongst a group of users) may have some advertising value due to geo-location techniques. Geographically-specific advertisements may be provided to the geo-located user, although there remains the possibility that such advertisements may be less accurately targeted than an advertisement with a specific geographic affiliation.

[0094] Advertisements may also be more accurately tracked with regard to actual impressions thereby allowing for more accurate determinations of advertising campaign value or proper remuneration to a provider of the advertisement relative those impressions. For example, an advertisement may have 1,000,000 impressions over a 2 week period. While this number may be impressive in a vacuum, when it is learned that 75% of those impressions occurred in a geographic region where the product or service is unavailable, the number of impressions becomes much less valuable. Many of the impressions were wasted on portions of the consuming public that will not or, perhaps even worse, cannot purchase the service or product. Thus, an advertiser can purchase a particular number of impressions with the caveat that those impressions be within a particular geographic region to count against a total overall ad buy.

[0095] Direct targeting of users may also take place using variations of the aforementioned identification methodologies. For example, in the registration

scenario, a user may provide certain 'likes' or 'dislikes' in a user profile generated during the registration process. A user may indicate favorite sports teams, favorite hobbies, and the like. As a result of the user profile reflecting that a user is a Boston Red Sox fan, the user may be presented with certain advertisements that relate to World Series Memorabilia from the Red Sox 2004 World Series victory, and not a compilation of the New York Yankees World Series victories. Similarly, a user that identifies an affiliation with the San Francisco 49ers may receive 49er related advertisements instead of advertisements related to the Oakland Raiders.

Alternative or more generic profile factors may also be implemented and/or utilized as are available and/or relevant to a particular advertiser.

[0096] This type of targeted advertising may be extremely useful when a product or service is available nationwide but has limited popularity or sales in particular regions. For example, a product may be available over the Internet (*e.g.*, through Amazon.com) but also available at a number of brick and mortar stores in one particular region of the country (*e.g.*, the West Coast). A user on the East Coast might purchase these products if he was aware of particular sale opportunities or new product releases. If that user does not live on the West Coast where an advertising campaign is in effect, however, they may never receive advertisements related to that product as advertising dollars have been allocated to a locale where brick and mortar stores are located. If the East Coast user indicated an affinity for a particular product in a profile, advertisements can be presented to this user via the in-game advertising system 100 even though the user lives in a region where product sales are otherwise low and advertising (in traditional media forms) is low or entirely non-existent. Through such targeted advertising, not only are impressions generated amongst able buyers, but also amongst willing and highly interested buyers making each impression all the more valuable.

[0097] Certain learning intelligence may also be implemented to aid in the direct or geographic targeting advertising process. For example, a game user may participate in an on-line baseball league. Registration for that league may be limited solely to a user name and billing information. If the user resides in Southern California, it would be (as a broad-based assumption) unlikely for this game user to

be a fan of the Florida Marlins and (as another assumption) probably a fan of the Los Angeles Dodgers or the Anaheim Angels. Such assumptions may prove to be false.

[0098] But if the same user, via the on-line baseball league, continually selects the Florida Marlins as his team of choice, the in-game advertising system 100 may recognize the repetitive behavior (*e.g.*, the selection of a particular team, or a particular character in a game). Based on the repetitive behavior of the user, an assumptive profile of a user may be generated.

[0099] Further, if the user plays the networked/on-line baseball league fifteen times and elects to play with the Marlins fourteen of those times, it would be an intelligent assumption that the user is a Marlins fan even though the user lives in Southern California. As a result, certain advertisements in the game environment may be directed toward fan merchandise for the Florida Marlins, instead of for the Dodgers or a random advertisement.

[00100] Such targeted advertising is not limited to favorites or affiliations of the user. Direct targeting may also utilize demographics such as gender, age, and the nature of the game itself. Gender may be specifically identified or presumed based on the content of a video game. Age may be based on a specific identification or a presumption related to the maturity of a particular game. The nature of the game itself may indicate demographic information of the user or relevant advertising content. For example, a sports game may generate sports advertisement whereas role playing games may generate advertisement specific to the nature of the game such as combat or fantasy. Various combinations or subsets of targeted advertising may also be utilized (*e.g.*, age and gender relative a particular genre of video game).

[00101] These intelligent determinations or analyses based on various demographics may take place at the advertisement server 130 via an appropriate software module providing for such deductive or intelligent determinations.

[00102] It should be noted that the present disclosure describes numerous inventive components that may operate individually or with other inventive components outlined herein. One such inventive component—tracking what advertisements the user sees—involves monitoring the view perspective of the user (*e.g.*, the point-of-view of the game character or of the actual user via a game camera)

and calculating when the user has experienced an ad impression. One embodiment of this method further allows for object occlusion detection. Such impression information may then be returned to an ad server 130 or other component of the system 100 as described in FIGURE 2.

[00103] FIGURE 8 illustrates line-of-sight obstacles as may be found in a game environment 800. FIGURE 8 illustrates a game character 810 (as reflected by the camera icon), an advertisement 820, one or more obstacles 830-880 and line-of-sight 890 relative the game character 810 and its current viewing orientation to the advertisement 820. It should be noted that any references to a game character in the present disclosure is also inclusive of a game camera as to include various points-of-view of the game character of the video game as well as that of the actual user. In one embodiment, the point-of-view is that of the actual user (player) of the video game such that the impression of an advertisement or other information is actually that of the user as would be most like an advertising impression in the real-world. Obstacles 830-880 may be representative of any object in the gaming environment 800. Walls, corners, pillars, objects (*e.g.*, boxes, signs, rows of lockers, doors, etc.), other game characters, opaque glass or even other advertisements (that is, not advertisement 820) may be representative of the obstacles 830-880.

[00104] In an ideal advertising environment, game character 810 and advertisement 820 would be separated by an unbroken line-of-sight. That is, obstacles 830-880 would not break line-of-sight 890 whereby game character 810 (and its controlling user through, for example, a first-person game view) would have a full and uninterrupted view of and exposure to advertisement 820. Such an uninterrupted view of and exposure to advertisement 820 is desirable in that it provides for an advertising impression most like that as would be encountered in the real-world (*e.g.*, reading a newspaper advertisement, viewing a billboard or attentively viewing a television commercial). That is, persons in the real-world are generally able to view an advertisement (or at least position themselves) such that other objects in the environment do not obscure a view of that advertisement.

[00105] But as is shown in FIGURE 8, line-of-sight 890 is interrupted at multiple points by obstacles 830, 840 and 850. Obstacle 830 may be a stack of boxes whereas

obstacle 840 may be a soda machine while obstacle 850 may be a corner in a hallway. The exact nature of obstacles 830, 840 and 850 is irrelevant except for the fact that they are interrupting line-of-sight 890 between game character 810 and advertisement 820. Such a scenario as illustrated in FIGURE 8 is common in complex game environments such as those offered by role-playing or first-person adventure games, where users navigate through the gaming environment 800 and the objects that exist therein.

[00106] The interruption of the line-of-sight 890 as caused by obstacles 830, 840 and 850 may partially (or wholly) prevent the character 810 from viewing the advertisement 820. Depending on the exact angle of obstacles 830, 840 and 850, the character 810 may be able to see certain portions of advertisement 820, but those portions may be minimal compared to the greater portion of the advertisement 820 obscured by obstacles 830, 840 and 850. In some cases, an advertiser may have paid significant sums of money for the placement of advertisement 820 in game environment 800. However, the advertisement 820 may never be viewed as was intended by the advertiser (*e.g.*, a full-frontal observation of the advertisement 820 for a given period of time in order to allow the game user controlling game character 810 to review and comprehend the advertisement 820). The advertiser may, therefore, have expended certain sums of money with absolutely no end benefit as the user of the game (via character 810) did not view the advertisement 820. This lack of an advertisement impression results even though character 810 is actually standing directly in front of advertisement 820 and has their line-of-sight 890 oriented in the same direction.

[00107] FIGURE 9 illustrates a positional relationship between a game character 920 and an advertisement 910 in a game environment 900, in one embodiment in accordance with the present invention. In FIGURE 9, advertisement 910 is located at a predetermined position in the game environment 900. This positioning may be along a wall 950 in the game environment 900. For example, advertisement 910 may be a poster advertising an upcoming concert, advertisement 910 having been pushed into the game environment 900 by various components of the in-game advertising system 100 (FIGURE 1) (*e.g.*, via asset tagging, whereby the relevance or 'freshness'

of the advertisement 910 can be continually updated after the initial release of the game). In the present example, the advertisement 910 (poster) may be positioned on the wall 950 of, for example, a record store in the game environment 900.

[00108] The game character 920 may enter this particular portion of the game environment 900 (the record store) through, for example, an entryway 960. As can be seen in FIGURE 9, the game character 920, upon initial entry into the game environment 900, may be standing directly adjacent to and oriented toward the advertisement 910. Due to the positioning of the game character 920 relative the advertisement 910, however, the game character may not be able to actually see or be exposed to the advertisement 910 regardless of the orientation of the game character 920 in the general direction of the poster (advertisement 910).

[00109] The game character's 920 inability to view the advertisement 910 in FIGURE 9 is a result of the game character 920 being outside an impression area 930 defined, in part, by a combination of a first angle θ_i and a second angle θ_r relative to a surface vector 940. The first angle θ_i is the angle measured from a ray 970 to the surface normal 990 (θ) wherein normal incidence is an angle of zero. The second angle θ_r is the angle measured from a ray 980 to the surface normal 990. The second angle θ_r , at least with regard to isotropic surface, is identical to the first angle θ_i (*i.e.*, $\theta_i = \theta_r$). In FIGURE 9, the first angle θ_i and the second angle θ_r each have an angle of about 30° relative the surface normal 990.

[00110] The surface vector 940 comprising a unit length (*e.g.*, a distance from the advertisement) further defines the impression area 930 for a predetermined distance from the surface of the advertisement 910. The surface vector 940 relative the advertisement 910 is defined, for example, as being 20 feet. Absent any obstructions in the impression area 930, if the game character 920 is within 20 feet of the advertisement 910 and within the angles defined by first ray 970 and second ray 980 (*i.e.*, $\pm 30^\circ$ relative the surface normal 990), then the game character 920 is within the impression area 930.

[00111] A user controlling the game character 920 within the impression area and facing the advertisement 910 will be able to view the advertisement 910. That is, an impression will be established for the advertisement 910 as would normally occur in

the real world (*e.g.*, while the user is standing in front of a billboard). Alternatively, if the game character 920 is not within the impression area 930 as defined by first ray 970, second ray 980 and surface vector 940, then no impression is generated.

[00112] FIGURE 10 illustrates a second positional relationship between a game character 1020 and an advertisement 1010 in a game environment 1000, in one embodiment in accordance with the present invention. The game environment 1000 of FIGURE 10 is similar to that illustrated in FIGURE 9 with the exception of the position of game character 1020. In FIGURE 10, game character 1020 is positioned directly in front of and exposed to the advertisement 1010.

[00113] An impression area 1030 is defined in a manner similar to that of FIGURE 9. That is, a first ray 1070 and a second ray 1080 relative surface normal 1090 in conjunction with surface vector/distance 1040. Because game character 1030 is located within the impression area 1030 of the advertisement 1010 and the character's view is directed toward the advertisement 1010, an advertising impression is generated.

[00114] FIGURE 11A illustrates a positional relationship between a game character 1120 and an advertisement 1130 relative an obstacle 1140 in an impression area 1110 in a game environment 1100, in one embodiment in accordance with the present invention. The impression area 1110 of the game environment 1100 is defined in a manner similar to that of FIGURES 9 and 10 (*e.g.*, a first and second ray relative a surface normal with a predetermined distance relative the advertisement 1130). Game character 1120 is positioned within the impression area 1110 and the orientation of the line-of-sight of the game character 1120 is toward the advertisement 1130. The line-of-sight from the game character 1120 to the advertisement 1130 is, however, at least partially obscured by the obstacle 1140 within an obstructed area 1145.

[00115] With the increased graphic complexity of many video games, placement of objects about a game environment increasingly provides a challenge to creating advertising impressions. For example, in FIGURE 11A, due to the position of the game character 1120 relative the obstacle 1140, the game character 1120 cannot view

the advertisement 1130. Therefore, no advertising impression is made to the user controlling the game character 1120.

[00116] Determining whether a game character falls within an obstructed area can be accomplished by using line-of-sight determination. In FIGURE 12, obstructed line-of-sight 1220 is shown between game character 1200 and advertisement 1210, in one embodiment in accordance with the present invention. FIGURE 12 also shows unobstructed line-of-sight 1250 between game character 1200 at a different position relative advertisement 1210. The determination of obstruction may be established by testing line-of-sight 1220 (or 1250) between game character 1200 (1200') and advertisement 1210 that passes through a center of obstruction probe 1225.

[00117] In some embodiments, obstruction probe 1225 is a spherical object with a predetermined radius r . Obstruction probe 1225 travels along the line of sight 1220 (or 1250) between game character 1200 (1200') and advertisement 1210. If obstruction probe 1225 does not collide with any obstacles, then the line-of-sight between game character 1200 (1200') and advertisement 1210 is unobstructed. If game character 1200 is located in an impression area and oriented toward the advertisement 1210, an impression of the advertisement 1210 is generated. Unobstructed line-of-sight 1250 illustrates the absence of object obstruction between game character 1200' and advertisement 1210, which allows for an advertising impression.

[00118] Alternatively, line-of-sight 1220 is obstructed as a result of one or more objects 1230a . . . 1230c, preventing an advertising impression. If the obstruction probe 1225, while traveling along (obstructed) line-of-sight 1220 intersects one or more polygonal sides 1240a . . . 1240c of one or more objects 1230a . . . 1230c, where each of one or more objects 1230a . . . 1230c is typically constructed from multiple polygonal sides 1240a . . . 1240c, then an unobstructed view of the advertisement 1210 relative the game character 1200 is not possible and no advertising impression is generated notwithstanding the presence of the game character 1200 in an impression area. Such a scenario—an obstructed line-of-sight and absence of an advertising impression despite being in an impression area—is illustrated in the aforementioned FIGURE 11A.

[00119] In some embodiments of the present invention, partial viewing of and exposure to an advertisement may be sufficient to establish an advertising impression. For example, certain trademarks or logos have established a certain degree of notoriety within the purchasing public. For these famous or easily recognizable trademarks or logos, viewing even a portion of the trademark or logo may be sufficient to establish an advertising impression. Similar 'partial viewing impressions' may be acceptable with regard to slogans, celebrities, famous spokespersons, and so forth. In these instances, even though the obstruction probe 1225 may intersect with an object, if the intersection involves only a small percentage of the probe 1225, then a partial impression may be generated. If the object obscures the advertisement in its entirety—substantially 100% of the probe 1225 intersects with the object—then no impression is generated.

[00120] The radius r of the obstruction probe 1225 may be reduced whereby a collision with a polygonal sides 1240a . . . 1240c of one or more objects 1230a . . . 1230c may be avoided thus allowing for an unobstructed line-of-sight and, subject to presence in an impression area, establishing an advertising impression. In that regard, the radius r of obstruction probe 1225 may be determined relative to an advertisement to be viewed. Information relative the setting of radius r may be part of advertising data pushed to a video game environment by the advertising server 130.

[00121] In some embodiments of the present invention, especially those involving third-person points-of-view, it may be possible to overcome obstructed lines-of-sight in an effort to create an unobstructed line-of-sight. For example, in an in-game advertising system 100 (FIGURE 1) where payment of advertisement space is made in advance, an advertiser may seek to have their advertisement viewed at any cost. In these instances, a camera tracking the game character may be adjusted to provide an unobstructed line-of-sight to allow for viewing of the advertisement and creating an ad impression. Exemplary systems and methods for providing an unobstructed view of an advertisement or other target are disclosed in U.S. patent application number 10/268,495, which has previously been incorporated by reference.

[00122] FIGURE 11B illustrates a positional relationship between a game character 1170 and an advertisement 1180 relative an obstacle 1190 in an impression area 1160 of a game environment 1150. The impression area 1160 of the game environment 1150 and relative the advertisement 1180 is defined in a manner similar to that of FIGURE 9 and 10 (*e.g.*, a first and second angle relative a surface normal combined with a surface vector). Game character 1170 is positioned within the impression area 1160 but is not in an obstructed area 1195 as would be generated by obstacle 1190 like that described in FIGURE 11A. A determination of the lack of an obstruction area 1195 or the game character 1170 not being positioned in an obstruction area 1195 is determined in a manner similar to that as described in FIGURE 12. In that regard, an obstruction probe traverses a line-of-sight between the game character 1170 and the advertisement 1180 and does not intersect with a polygonal side of an object. The lack of intersection thus indicates the presence of an unobstructed line-of-sight and the establishment of an advertisement impression resulting from game character's 1170 exposure to the advertisement.

[00123] FIGURE 13A illustrates the correlation between an impression counter 1360 and the position of a game character 1320 relative an advertisement 1310 in a game environment 1300. Impression counter 1360 measures the time period that the game character 1320 is positioned in impression area 1330 with an unobstructed line-of-sight 1350 relative the advertisement 1310. As can be seen in FIGURE 13A, game character 1320 has an unobstructed line-of-sight 1350 of and exposure to advertisement 1310 notwithstanding the presence of object 1340 and obstructed area 1345.

[00124] It should be noted that impression counter 1360 is not necessarily a stopwatch or other timing device as depicted in FIGURE 13A. Impression counter 1360, in an embodiment of the present invention, is any timing mechanism governed by hardware or software relative an end-user client device 170 (*e.g.*, a gaming console) that may measure the time period that the game character 1320 is positioned in the impression area 1330 with an unobstructed line-of-sight 1350 relative the advertisement 1310 and may utilize various units and/or measure schemes. In one

embodiment, a temporal period is used as a unit of measure (*e.g.*, seconds, fractions of seconds and so forth).

[00125] FIGURE 13B further illustrates the correlation between an impression counter 1360 and the position of a game character 1320 relative an advertisement 1310 in a game environment 1300. In FIGURE 13B, however, the game character 1320 has moved behind the object 1340 and into the obstructed area 1345.

Notwithstanding the fact that the game character 1320 remains within the impression area 1330, the game character 1320 has an obstructed line-of-sight 1370 relative advertisement 1310. When the line-of-sight of the game character 1320 relative the advertisement 1310 becomes obstructed (as is reflected in FIGURE 13B), the impression counter 1360 terminates. That is, an impression of the advertisement 1310 is no longer being generated as the advertisement 1310 has been obstructed from the game character's 1320 view.

[00126] By measuring the length of exposure to an advertisement via impression counter 1360, an advertiser can determine the value of an ad impression or whether an impression has actually been made if the existence of an impression is tied to the duration of presence in the ad impression area (*e.g.*, the time of exposure to the advertisement). For example, a pricing model may be established wherein an advertiser is charged based on the duration of the advertisement impression. The duration of the advertisement impression is reflected by the impression counter 1360. In another pricing model, an advertiser may pay a fee for a certain number of advertisement impressions. An ad impression may be defined as unobstructed exposure to an advertisement for a certain period of time. For example, and as evidenced in FIGURE 13B, the game character 1320 is in the defined impression area 1330 but is unable to actually view the advertisement 1310. As such, the advertiser should not have the presence of the game character 1320 in the impression area 1330 with no view of the actual advertisement 1310 constitute an advertisement impression.

[00127] The various ad impression determinations may be implemented utilizing software downloads as discussed in the context of FIGURE 2 or through software installed on physical media (*e.g.* a software client on an optical disk) or may be pre-

installed in a gaming device. Various modules that interact with the ad impression determination software (*e.g.*, receiving ad impression information for reporting to an advertiser) may be further located in various other aspects of system 100 (*e.g.*, at ad server 130).

[00128] As noted, various pricing models may be based upon the existence of advertising impressions or the quality thereof. For example, an advertiser may be satisfied knowing that their advertising content has made it into a video game. Another advertiser may be more demanding and require information related to actual impressions. Using the methodology described in FIGURE 12 with regard to determining the existence of unobstructed lines-of-sight it may be determined whether the user actually viewed the advertisement.

[00129] Even more specific, it may be determined how long the user viewed the advertisement. For example, if a user is merely scanning around the room for an exit or a particular object, their line-of-sight may intersect with the advertisement but the scanning of the room was too quick to allow for any meaningful consideration or understanding of what the advertisement portrayed. In this scenario, a timer may be implemented as was described in FIGURES 13A and 13B.

[00130] On an even more detailed level, it may be possible to determine the quality of the impression. For example, a user may view an advertisement as a result of being in an impression area. That user may, however, be on the very far edge of the impression area and have slight difficulty viewing the advertisement. This might be the case if a user is utilizing a later model television or computer monitor or is utilizing a computing device that has lower graphics processing power.

Notwithstanding graphics output considerations, it is possible to further delineate the impression area into quality impression areas whereby the advertisement is viewed in every instance but better or worse depending on the exact placement of the game character when viewing the advertisement.

[00131] A game character may be face-to-face with an advertisement. The character, while clearly within the impression area, may be so close to the advertisement that he cannot fully view the advertisement or the copy that he can view is blurred because of the close proximity of the character relative the

advertisement in the gaming environment. Similarly, a user may be too far away to fully appreciate the advertisement. Through delineating quality impressions, advertisers can appreciate a minimal impression (*e.g.*, up close or almost too far away) but also have certain assurances with regard to quality impressions as may be subject to the particular whims of the advertiser.

[00132] Various pricing schemes may be based upon these various levels or quality of impression whereby a general impression is charged at one rate while a higher quality impression is charged at a different rate. Similarly, the length of time a user is in an impression area can be correlated to a pricing model. For example, if a user is in an impression area for 2-seconds, an impression may have been made but possibly a minimal one due to the complexity of the advertisement. If the user is in the impression area for 10-seconds, a greater impression has been made and has greater value to the advertiser. Limits may be imposed on such an impression counter such that an advertiser is not charged for a 30-minute impression when a user happens to position his game character in front of an advertisement and then leave to attend to another task for half-an-hour. Notwithstanding the presence in the impression area for that period of time, a thirty-minute impression has not truly been made as the user of the game (the controller of the character) has not been subjected to that advertising copy.

[00133] Traditional economic aspects of supply and demand may also come into play with various pricing models. For example, if a game is released with great fanfare and is a 'must buy for the holiday season,' ad buys in the game may be more expensive. If the game layer proves to be unpopular for a variety of reasons, the pricing levels may decrease to reflect the demand of the game. These determinations as to supply and demand may be made, in part, based on the location and intrinsic value definition of specific tags, the demand for a tag as driven by the number of times tagged assets in a video game are identified during average, peak and off-peak game play thereby resulting in various requests to the advertising server 130, which may be counted as have been previously described in the context of FIGURE 2.

[00134] Similarly, certain video games may have indicia identifying a distinct owner as a result of a user profile or information embedded on the game or subject

to, for example, a network address. An advertiser may also determine that while 1,000 impressions may have occurred for their advertisement on a particular day that almost half of those were related to a small group of users who continually entered a gaming environment where the advertisement was rendered time-and-again versus 1,000 impressions distributed more equally amongst 800 different, unique game players. The impressions in the latter example are more valuable than the repeated impressions amongst a small group of users in the first example.

[00135] Certain embodiments of the exemplary in-game advertising system 100 described in the present invention may also allow for certain interactions with the products advertised in a video game. For example, a game player might approach a vending machine whereby a variety of beverages are available and effectively advertised via their labeling, trademarks or other visual indicia. A user might select a particular beverage for his character to enjoy in the course of the video game by pressing a button on his keypad that corresponds to purchasing a particular beverage from the vending machine. These 'virtual purchases' may be conveyed to advertisers in that the advertisement has not only made an advertising impression in that a user has seen the product or related advertising but taken some sort of positive interaction with the product (*e.g.*, purchasing the product in the video game).

[00136] Similar game metrics may be implemented with regard to negative connotations. For example, if four beverages are available, the user's selection of one beverage may reflect negatively as to the other three. By further example, a user may be presented with a vending machine for two competing beverages; if the user takes some action relative one of the vending machines (*e.g.*, destroying it with a weapon), that act too may reflect negatively relative advertising metric information.

[00137] Through tracking user interactions with advertisements in a video game environment, the video game effectively becomes a user feedback service similar to an advertising focus group. Feedback may also be registered through explicit interactions wherein a user may expressly provide their opinion of a product or service relative the game environment. For example, the user may be prompted as to their opinion of a particular product; the user may then press 'up' for a positive reflection or 'down' for a negative reflection.

[00138] Interactions via, for example, a microphone input are also possible wherein the user provides feedback in connection with the advertisement. Such feedback may be transmitted to an agent on the other end of the communication channel or passed through speech recognition software wherein certain keywords as they relate to a product are recognized and categorized.

[00139] To address the feedback features, the impression tracking system may include functions or may interact with functions capable of soliciting or recording user reaction to an advertising campaign. For example, an advertiser may deploy an advertising campaign defined by advertising content that is loaded into a tag with program or pointer to program(s). Such programs may signal the user to perform actions. Other programs may monitor user reaction in and about the advertisement or in response thereto. For example, one such program that may be invoked when accessing a loaded advertisement tag includes a reference to a speech input requirements and definitions.

[00140] Advertising beyond the traditional flat, print advertisement may also be implemented utilizing the presently described in-game advertising system 100. For example, in addition to billboards or single page ad copy, rotating billboards may be utilized wherein triangular panels in the billboard rotate relative to one another thereby effectively providing three-billboards-in-one. The billboard panels then rotate every few seconds to reflect a new advertisement on each panel as occurs in the real-world. In this way, a single game asset can be tagged for multiple advertisement introductions.

[00141] Other ads in a game environment may be movable. For example, advertisements may be located on the sides of buses that traverse city streets or a series of flyers that might blow down an alley. Television ads with full motion video and audio ads as might be emitted over a radio or a telephone in a gaming environment are also envisioned as being implemented in the present invention.

[00142] Just as certain advertisements have higher demand in the real-world (*e.g.*, high traffic areas), certain advertisements in a video game environment may enjoy higher pricing as a result of high traffic areas. For example, advertisements that appear in the beginning of a video game or a level wherein every user will view the

advertisement inherently have more value than an advertisement located in a 'secret Easter Egg' level or extremely difficult level that many users may never reach.

[00143] Other embodiments of the present invention may include rewards based on user interaction with particular advertisements. For example, if a user provides actual feedback in a video game environment, the user may receive merchandise, points or coupon rewards from the producer of the product as an appreciation for their opinion. Such information concerning where to send a reward may be expressly provided during a feedback session or as a result of an association with a user profile. This latter case would be valuable wherein points or rewards are offered for less explicit interactions (*e.g.*, not in response to an advertiser/feedback query) such as casual interactions or favorable behavior relative an advertised product and points or rewards accumulate over time.

[00144] Advertisements, especially those ads that are audible in nature or are full motion video, may be subject to real-time limitations. For example, a user in a video game may be changing the channels of a television in the video game environment. If the user only watches two seconds of the advertisement, an impression may or may not be generated. Such limitations in the case of real-time advertising may be subject not only to an impression area but also an impression time and even an impression time relative particular portions of the advertisement.

[00145] For example, an advertisement may be thirty-seconds in length but the first five-seconds do not indicate the nature of the product and the last five-seconds concern legal boilerplate required by the particular advertisement. If an impression time is identified as five-seconds, watching the first or last five-seconds of this particular advertisement would technically constitute an impression notwithstanding the fact that the user knows nothing more about the product after those five-seconds than he did prior. In these cases, limitations as to impressions of particular portions of an advertisement may be implemented. For example, for an advertiser to consider there to have been an impression, the user must not only view five-seconds of the advertisement but those five-seconds must be within the middle 20-seconds of the 30-second advertisement.

[00146] Video or audio ads may also be subject to start-stop loops. That is, the advertisement starts when the user accesses the advertisement (*e.g.*, tunes to a radio station playing the advertisement) and then stops when the user leaves the advertisement (*e.g.*, changes the radio to another station). If the user then changes back to the original station with the advertisement, the ad may commence where it left off as if no time has passed. Such a methodology better ensures an impression but does so at the risk compromising reality (*i.e.*, real-time passage of time is not in effect). The tag object may track the state of the advertisement impression, such as the index into the location in a video file to start the next sequence for the one or more tags associated with the advertising loop.

[00147] Video games, radios and televisions that offer the user the ability to change channels may be associated with features to track multiple advertisement impressions and campaigns. When a user changes a channel or directs a virtual character in the game environment to change a channel, new advertisements may be provided. Such advertisement changes may be transitioned with white noise or a familiar blur associated with changing a channel according to the nature of the device. Radio or television devices may be configured with channels that access both traditional programming, advertisement content or other content. Other content may include chat wherein the device facilitates communications. Other content may also include other information in connection with the game. Generally, the mixing of advertisement and other content in such devices may have the benefit of catalyzing user exposure to advertisements since the use of the device and changing of the channels may be necessary to facilitate game play.

[00148] Other advertisements may be rendered or emitted in true real-time. For example, if a television advertisement in a video game is two minutes in length and the user changes the channel in the video game after thirty-seconds of viewing the advertisement but comes back to the same channel thirty-seconds later, the advertisement will now be at the 60 second point and not the 30 second point as in a start-stop embodiment.

[00149] While real-time advertisements may be more realistic, ensuring an impression becomes more difficult relative the portion of the advertisement the user

viewed as has been previously noted. Certain impression, especially in the real-time video and audio sense, may be subject to ongoing impression limitations. For example, an impression may constitute viewing 30 seconds of a one minute advertisement. The user may, at one point in the game, view a first 10-seconds of the advertisement, view a second 10-seconds at a different point in the game and view yet another 10-seconds at another point in the game. In this instance, the user—albeit piecemeal—may have viewed enough of the ad over the course of time to constitute an impression.

[00150] Other advertisements may limit an impression opportunity to consecutive time or such piecemeal viewing/listening but within an overall time frame. For example, viewing the advertisement in 10-second snippets may suffice as an advertisement but they must occur within 15 minutes of one another. Other advertisements may require the thirty-seconds to occur consecutively or an impression has not been established.

[00151] Some of these real-time/consecutive impression implications addressed above are reflected in FIGURE 14 of the present application. FIGURE 14 illustrates the positional relationship of an in-motion game character 1420 relative an advertisement 1410 in an impression area 1430 in a game environment 1400. In FIGURE 14, the game character 1420 is positioned in the impression area 1430 of advertisement 1410. The impression area 1430 is also populated with obstacles 1440A . . . 1440D. As the game character 1420 traverses the game environment 1400, the line-of-sight of the game character changes from an obstructed line-of-sight (as would occur behind obstacles 1440A . . . 1440D) and an unobstructed line-of-sight 1450A . . . 1450D. An impression counter (not shown) would move between an on-and-off state as the line-of-sight alternates between obstructed and unobstructed (1450A . . . 1450D) lines-of sight.

[00152] For example, as the game character 1420 moves past object 1440A, the impression counter would begin to measure the existence of an ad impression as provided by unobstructed line-of-sight 1450A. As the game character passes behind object 1440a, the impression counter would stop measuring the existence of an advertisement impression as a result of now obstructed line-of-sight. Once the game

character 1420 emerges from behind object 1440_a, an unobstructed line-of-sight (1450_B) once again exists and the impression counter again would begin to measure the existence of an advertisement impression from the stop point of the previous impression. The measurement of an advertisement impression would continue in a similar fashion as the game character 1420 passes in between remaining objects 1440_B ... 1440_D.

[00153] In the present embodiment, as the impression counter starts-and-stops, any one segment of time correlating to an advertisement impression may not constitute a single advertisement impression. The ongoing exposure to the advertisement 1410, albeit in an interrupted fashion, may over the course of time constitute an ad impression. For example, by the impression counter reaching a certain time period (*e.g.*, from start point to a point three seconds in time later), this time period may (as a whole) constitute an ad impression. Such a measurement methodology would be desirous in instances where a game character passes by, for example, a number of pillars; a rod iron fence, a series of windows, or a crowded room.

[00154] The above description is illustrative and not restrictive. Many variations of the invention will become apparent to those of skill in the art upon review of this disclosure. The scope of the invention should, therefore, be determined not with reference to the above description, but instead should be determined with reference to the appended claims along with their full scope of equivalents.

[00155] For example, the embedded advertising 'tags' as described in the present invention may be further applied to digital video and audio signals—television and audio broadcasts, for example—as well as movies filmed in a digital format whereby advertisements or other content may be inserted into previously generated audio and/or video content. On-line media such as on-line magazines, newspapers and blogs may also benefit from the implementation of tagging advertising assets (*e.g.*, particular column inches or steaming news broadcasts) as present-day advertising methodologies such as pop-ads become less effective and/or less popular. Advertising content may be offered by network and/or content providers (*e.g.*, cable providers) whereby advertising content is offered on-demand.

[00156] Additionally, the various impression area and occlusion concepts disclosed herein may be applied to audio advertisements or other audible emissions. For example, a radio or other audio emitting object may be defined, in part, by an impression area. Such an impression area would be determined in a manner similar to an impression area as it concerns a visual advertisement. An impression area in the context of audio would be representative of where an audio advertisement or other audio emission may be heard by the character in a game environment as the volume of the audio emission decreases as the character moves further away from the advertisement in three-dimensional space or if the character is located behind an object in which case the occlusion determination concepts become applicable (*e.g.*, does a wall separate the character and the audio signal). The quality of audio impressions may also be determined in a manner similar to quality determinations with visual advertisements with regard to not only distance but the extent to which an intermediate object might absorb the sound, for example, a pane of soundproof glass versus a thinly constructed wall.

[00157] The asset tagged to receive an advertisement may be movable and rotatable and may be programmed to dynamically orientate towards the user camera as the user manipulates around the game environment. Ad campaigns may be interleaved with special programming. Special programming may influence ad campaigns, variables in the tags relating to the ad campaigns, or may relate to the game environment. Special programming may influence (*e.g.*, terminate or replace) an ad campaign or modify variables or functions contained in an ad campaign or tag. Special programming may accommodate for dynamic reconfiguration and reuse of an advertising asset. For example, special programming may be used to communicate special messages, game messages, forum messages, facilitate chat and so forth. Special programming may also be used to transfer control of the advertising asset to the game environment so that the advertising real estate can be used to convey game information and other information.

[00158] Notwithstanding the providing of detailed descriptions of exemplary embodiments, it is to be understood that the present invention may be embodied in various forms. Therefore, specific details disclosed herein are not to be interpreted as

limiting, but rather as a basis for the claims and as a representative basis for teaching one skilled in the art to employ the present invention in virtually any appropriately detailed system, structure, method, process, or manner.

WHAT IS CLAIMED IS:

1. A method for delivering and tracking advertising content in an end-user client device, comprising:
 - identifying an advertising asset in a video game environment, the advertising asset comprising a tagged area;
 - delivering the advertising content to a memory at the end-user client device;
 - storing the advertising content in the memory at the end-user client device;
 - retrieving at least one advertising image from the advertising content stored in the memory and rendering the advertising image in the tagged area of the advertising asset in the video game environment; and
 - monitoring the video game environment to calculate ad impressions in response to user movements and user exposures to the advertising asset in the video game environment.
2. The method of claim 1, wherein calculating ad impressions further comprises determining whether an object occludes a line-of-sight of the advertising asset.
3. The method of claim 1, wherein calculating ad impressions further comprises determining whether an object does not occlude a line-of-sight of the advertising asset.
4. The method of claim 1, wherein the advertising content includes element types selected from the group consisting of programs, objects, state data, control data, textures, bitmap images, compressed images, sequencing data, authentication data, public key and private key.
5. The method of claim 4, wherein the advertising content comprises a program configured to capture a user reaction to the advertising asset.
6. The method of claim 1, further comprising:

identifying a characteristic of a user of the end-user client device; and
selecting the advertising content for delivery to the memory at the end-user client device based on the characteristic of the user of the end-user client device.

7. The method of claim 6, wherein the identified characteristic is from a user profile of the user.

8. The method of claim 6, wherein the identified characteristic is from information provided by a network service provider.

9. The method of claim 6, wherein the identified characteristic is associated with a network address of the end-user client device.

10. The method of claim 6, wherein the selected advertising content comprises geographic advertising content.

11. The method of claim 7, wherein the identified characteristic identified from the user-profile comprises a user preference.

12. The method of claim 6, wherein the identified characteristic is from a user profile of the user, and the identified characteristic from the user-profile comprises geographic information.

13. The method of claim 1, further comprising:

identifying a characteristic of the video game environment at the end-user client device; and

selecting the advertising content for delivery to the memory at the end-user client device based on the characteristic of the video game environment at the end-user client device.

14. The method of claim 13, wherein the characteristic of the video game environment comprises a demographic associated with the video game.

15. The method of claim 13, wherein the characteristic of the video game environment comprises a genre of the video game.

16. The method of claim 1, further comprising:

informing a payment processing center of the rendering of the advertising content in the video game environment; and

processing a payment associated with the rendering of the advertising content in the video game environment.

17. A system for delivering and tracking advertising content in a video game environment, comprising:

an end-user client device for rendering the video game environment, the video game environment comprising tagged advertising assets, the end-user client device configured to render the advertising content in the tagged advertising assets, the end-user client device further configured to monitor the video game environment to calculate ad impressions in response to user movements and user exposures to the advertising asset in the video game environment; and

an advertising server coupled to a database comprising advertising content, the advertising server configured to identify the existence of tagged advertising assets in the video game environment at the end-user client device, and to deliver the advertising content from the database to the end-user client device.

18. The system of claim 17, wherein the advertising server is further configured to identify a characteristic associated with a user of the end-user client device.

19. The system of claim 17, wherein the advertising server is further configured to identify a characteristic associated with the video game environment at the end-user client device.

20. The system of claim 17, wherein the database comprising advertising content further comprises targeted advertising content.

21. The system of claim 18, wherein the advertising content delivered to the end-user client device comprises targeted advertisement content associated with the characteristic of the user of the end-user client device.

22. The system of claim 18, wherein the advertising content delivered to the end-user client device comprises targeted advertising content associated with the characteristic of the video game environment at the end-user client device.

23. The system of claim 17, further comprising a payment processing center configured to process a payment associated with the delivery of the advertising content to the end-user client device.

24. A machine readable medium having embodied thereon a program being executable by a machine to perform a method comprising:

identifying an advertising asset in a video game environment at an end-user client device, the advertising asset comprising a tagged area;

delivering advertising content to a memory at the end-user client device, the delivered advertising content configured to be rendered in the tagged area of the advertisement asset in the video game environment; and

counting ad impressions generated at the end-user client device in response to user movements and exposures to the advertising asset in the video game environment.

25. The machine readable medium of claim 24, wherein the method further comprises:

identifying a characteristic of a user of the end-user client device; and

selecting the advertising content for delivery to the memory at the end-user client device wherein the selected advertising content is associated with the characteristic of the user of the end-user client device.

26. A system for delivering advertising content to a video game environment, comprising:

an end-user client device for rendering a video game environment, the video game environment comprising tagged advertising assets, the end-user client device for rendering the video game environment configured to render advertising content in the tagged advertising assets;

means for recognizing the existence of tagged advertising assets in the video game environment and to deliver advertising content to the means for rendering the video game environment; and

means for monitoring the video game environment to calculate ad impressions in response to user movements and user exposures to the advertising assets in the video game environment.

100

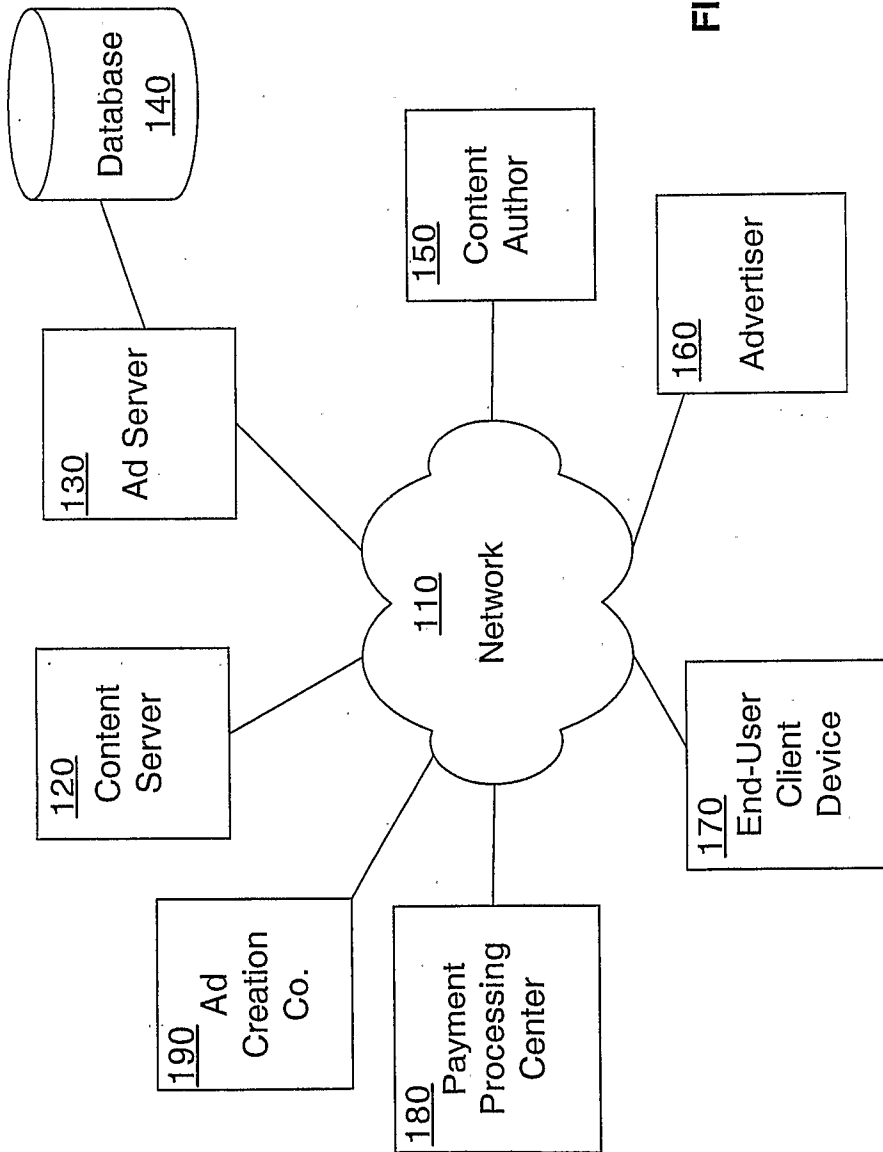

FIGURE 1

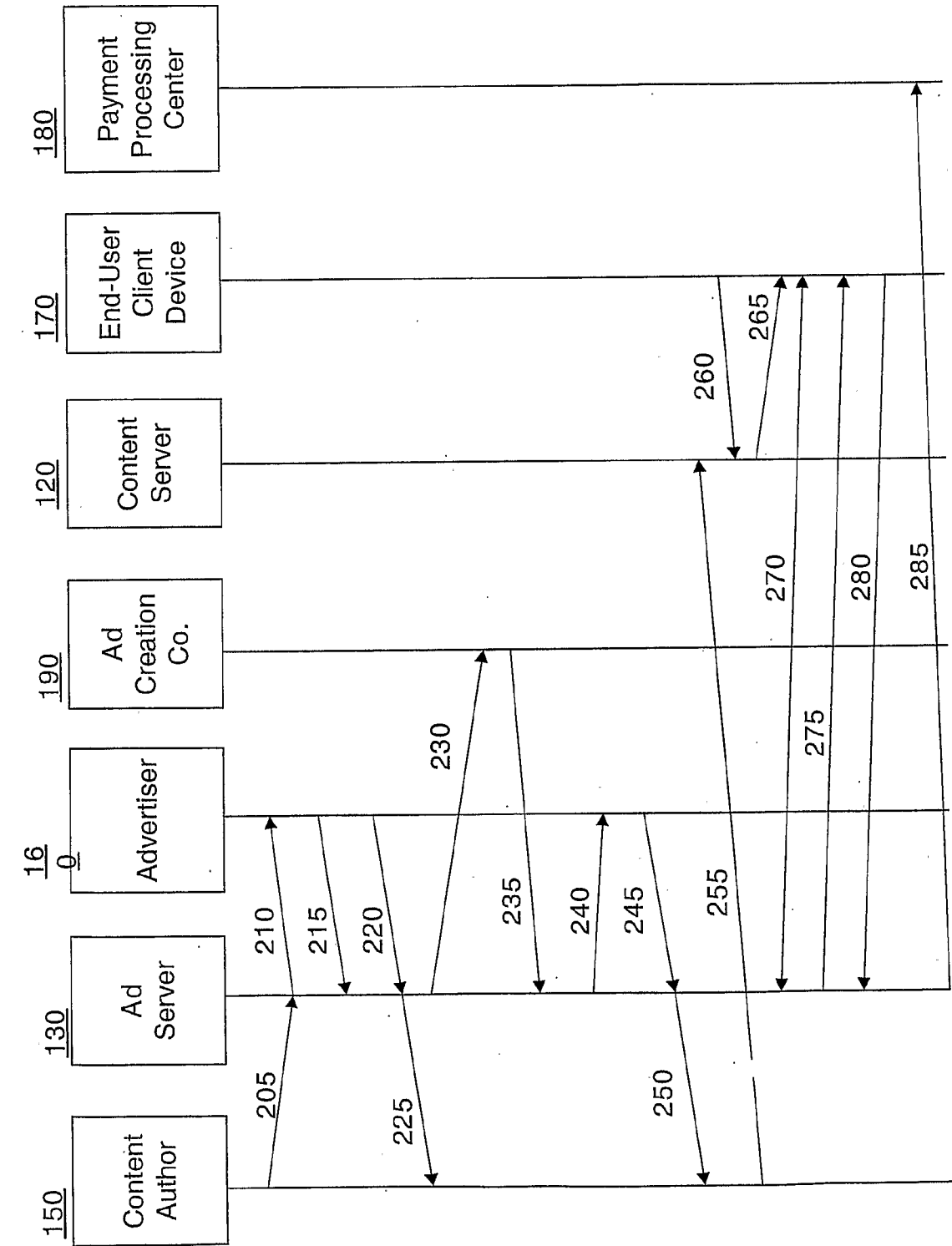

FIGURE 2

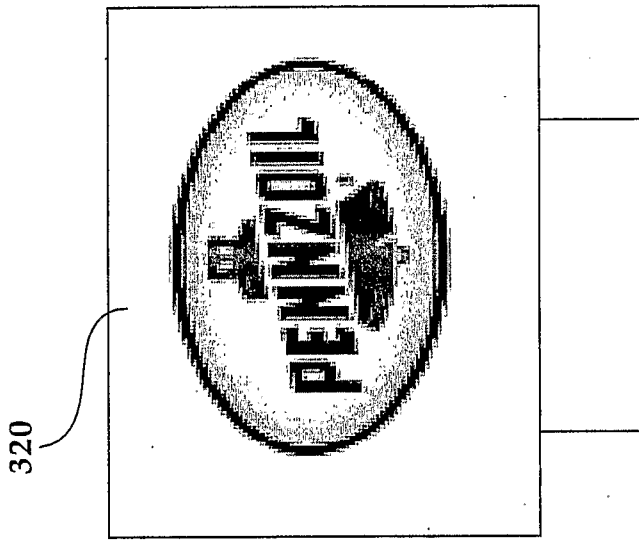

FIGURE 3B

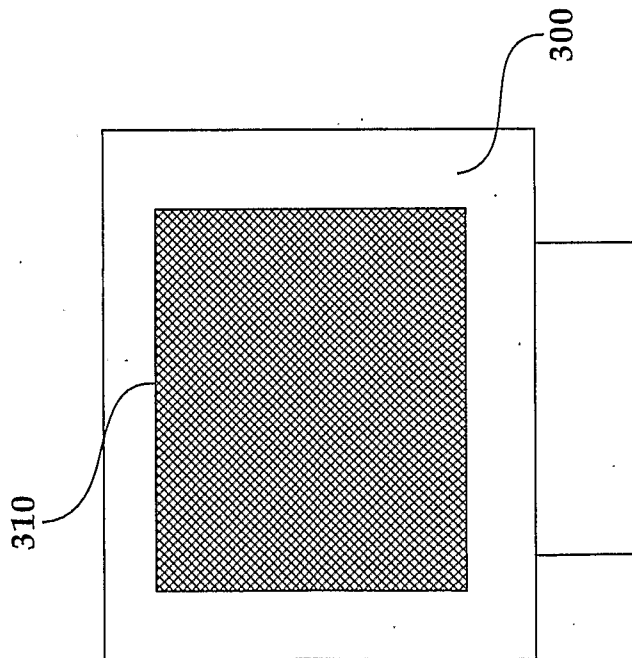

FIGURE 3A

400

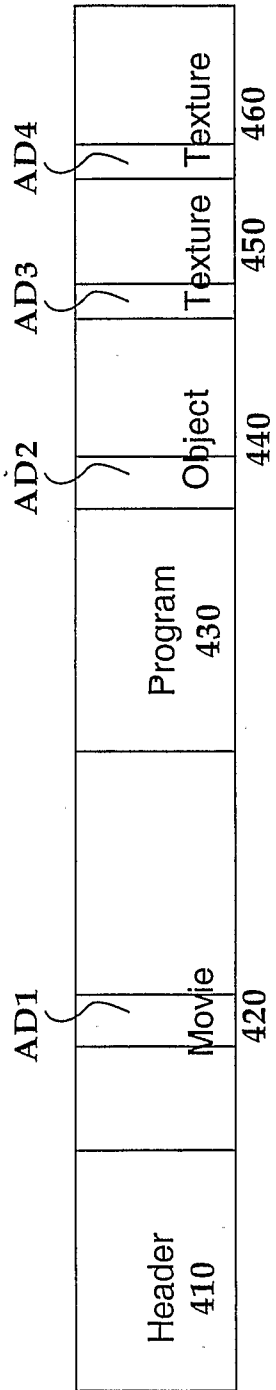

FIGURE 4

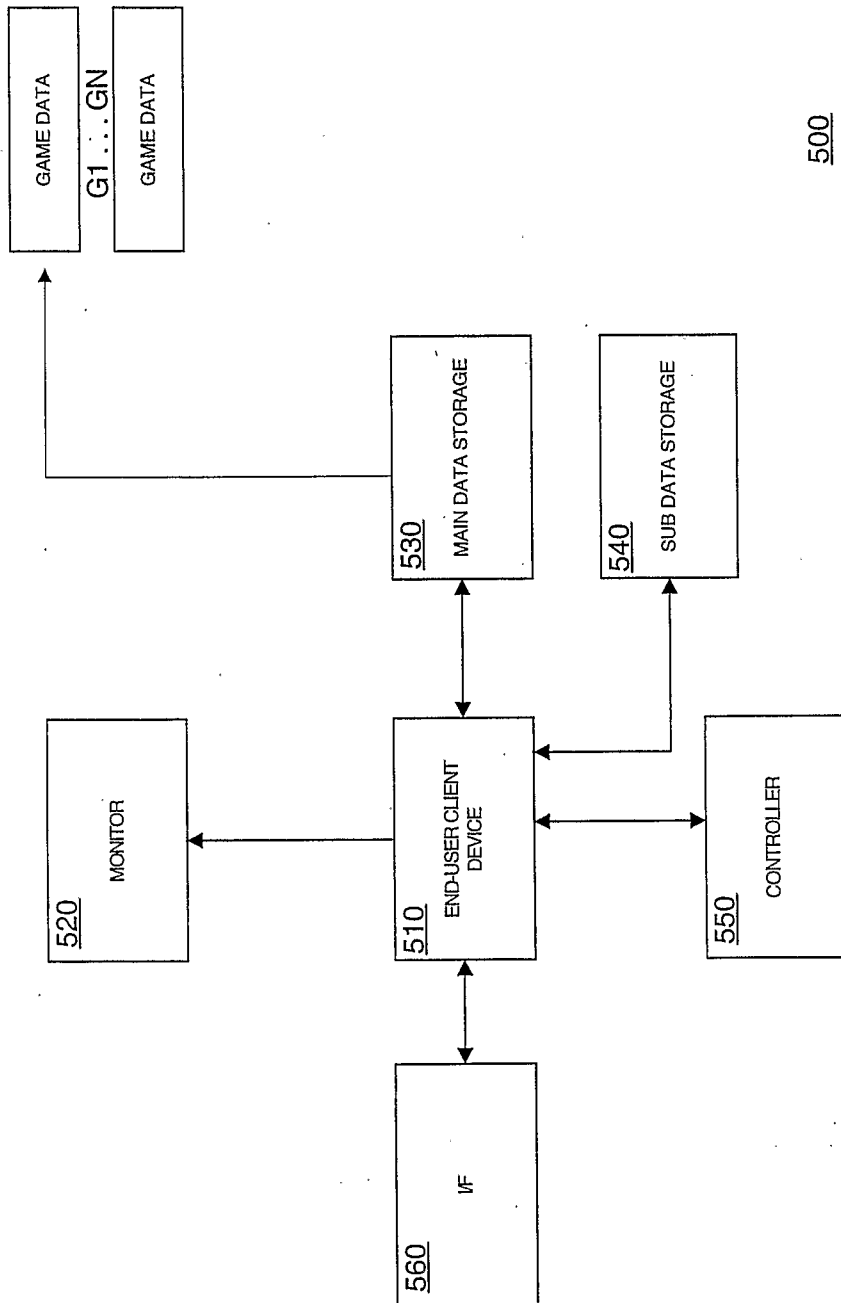

FIGURE 5

600

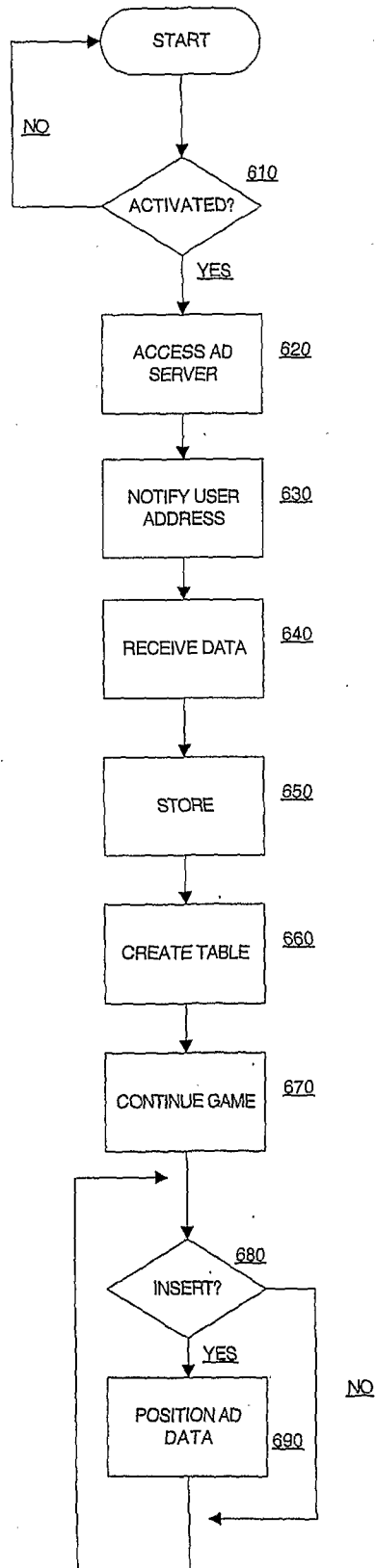

FIGURE 6

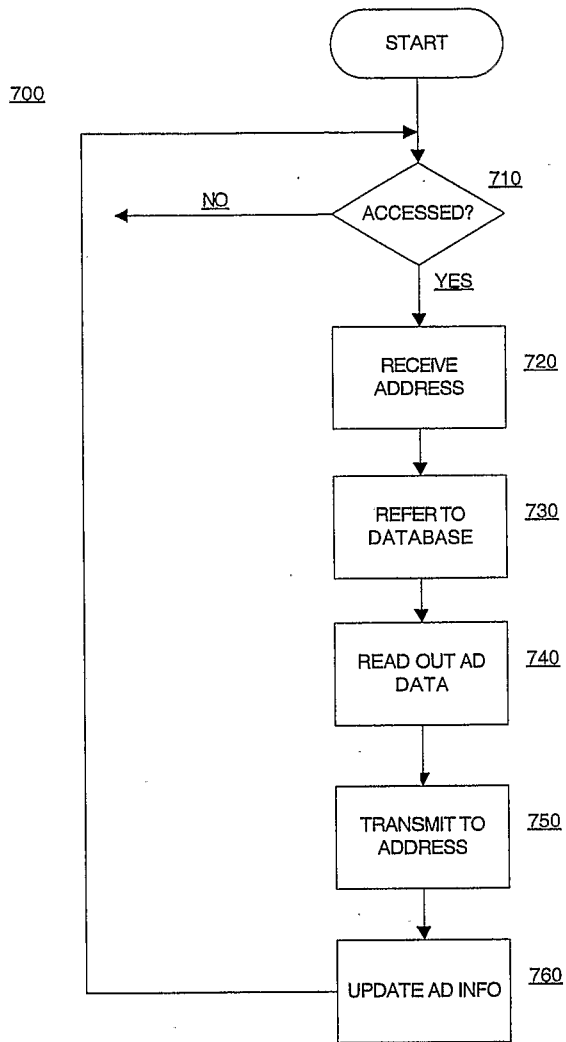

FIGURE 7

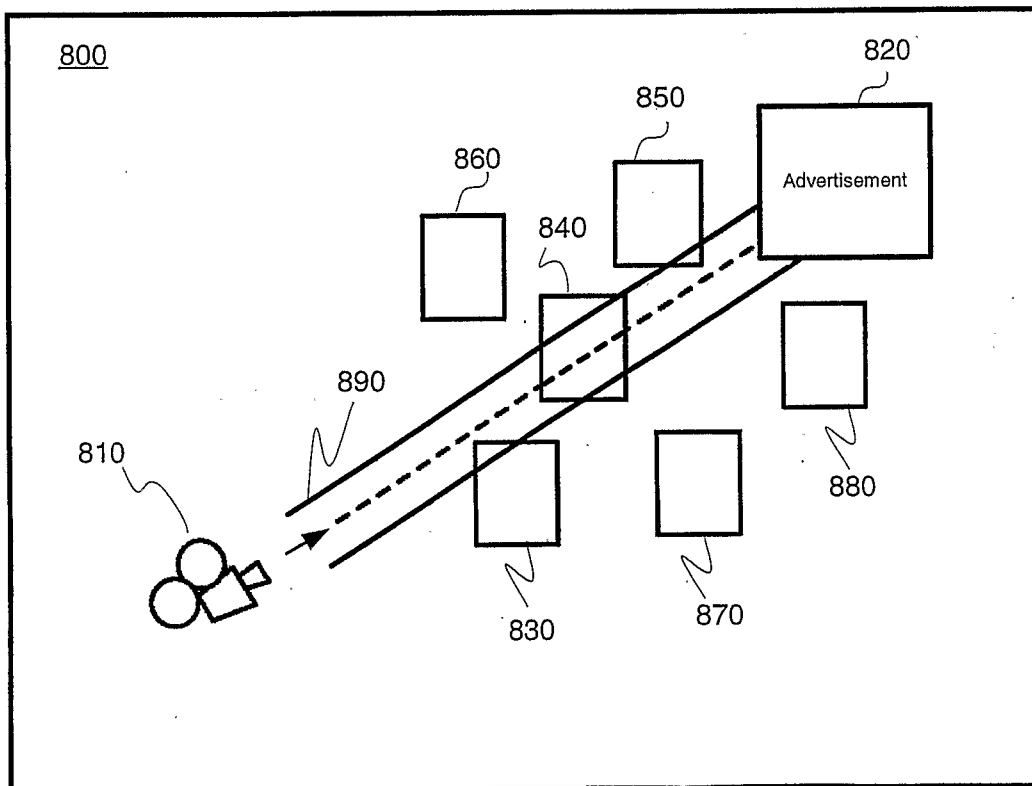

FIGURE 8

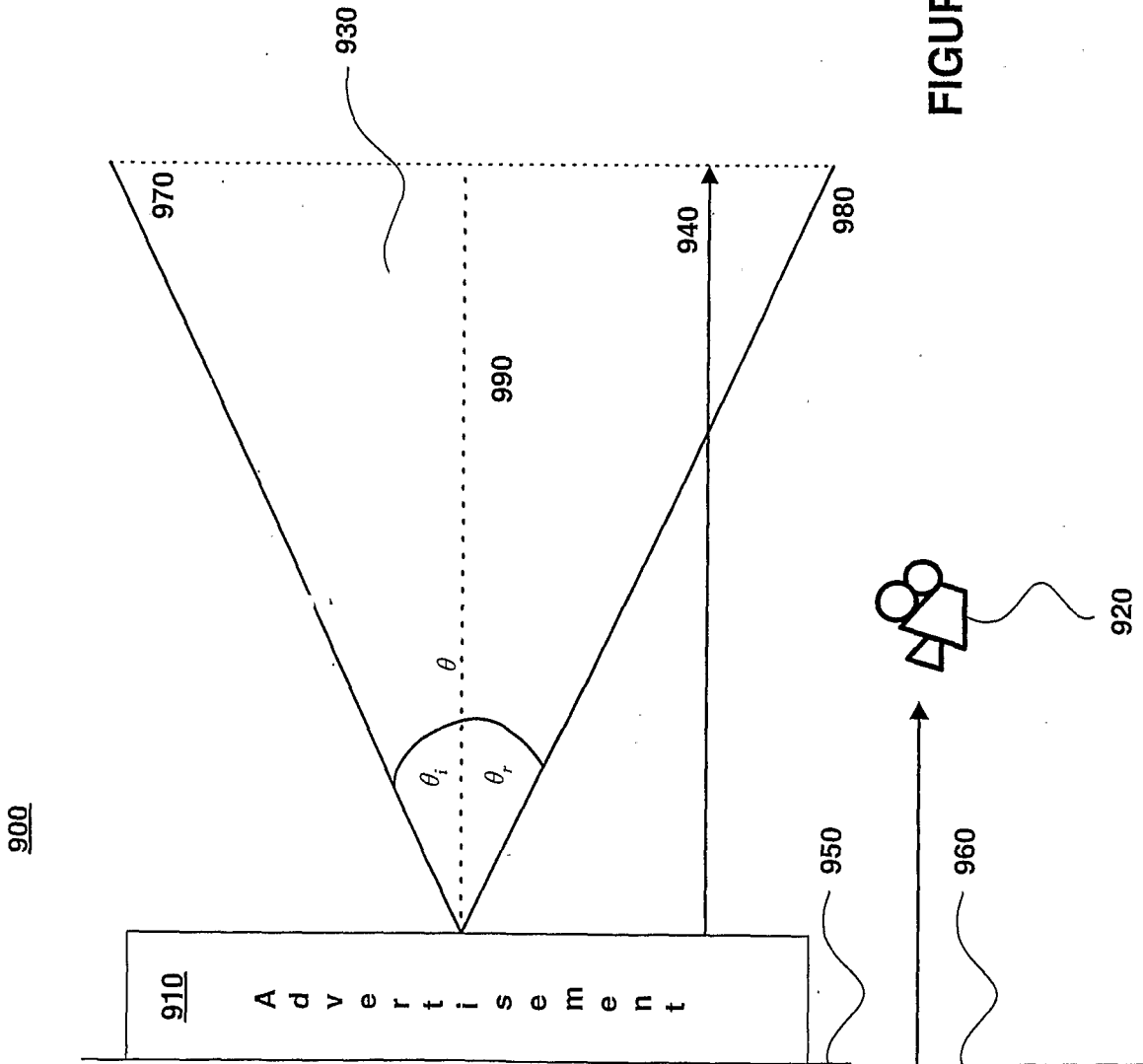

FIGURE 9

1000

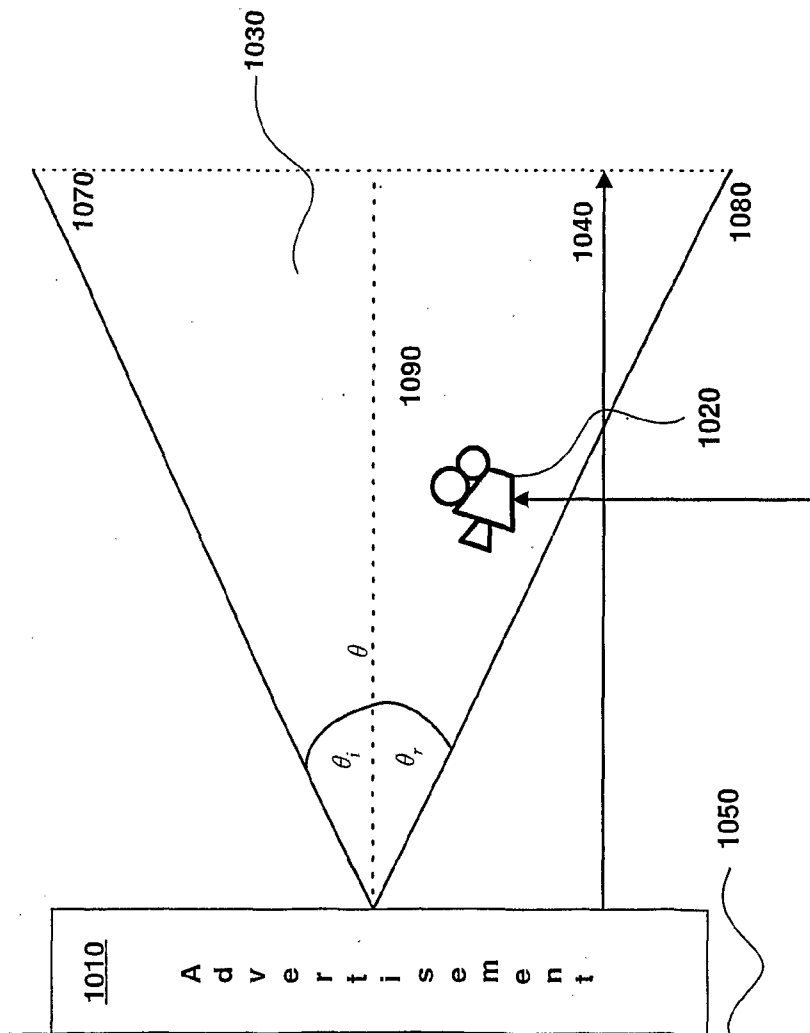

FIGURE 10

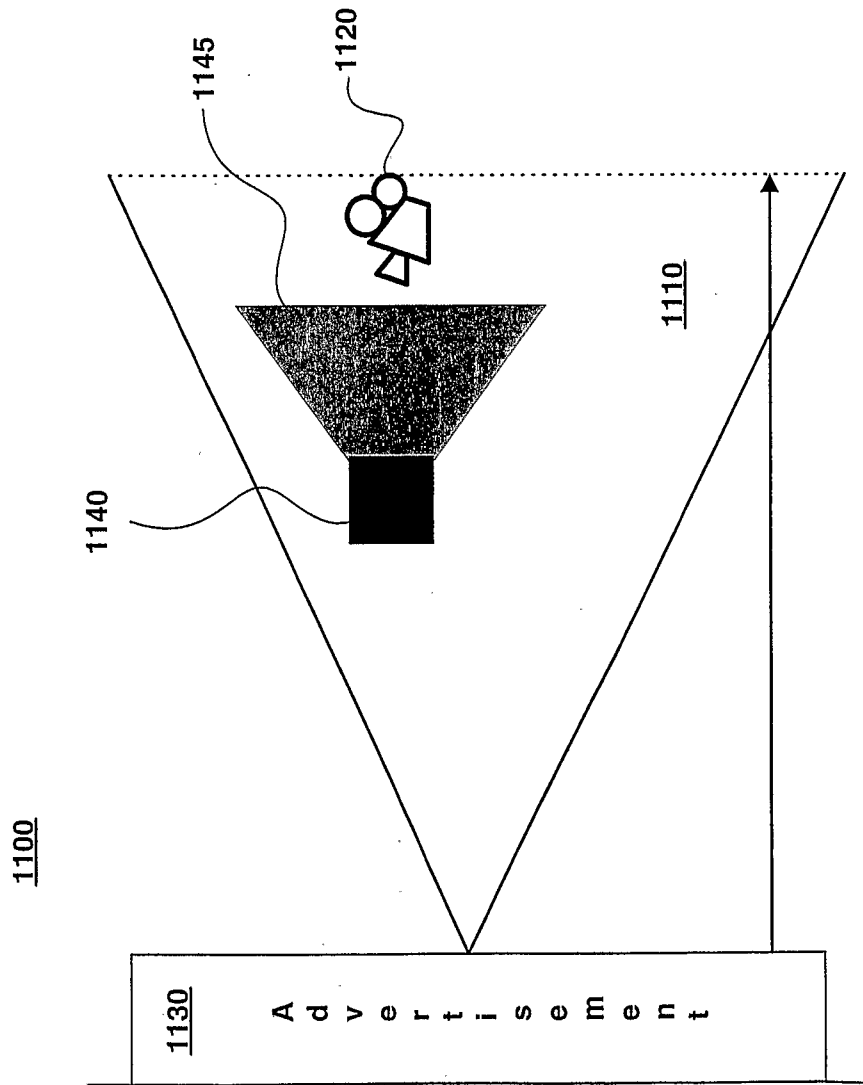

FIGURE 11A

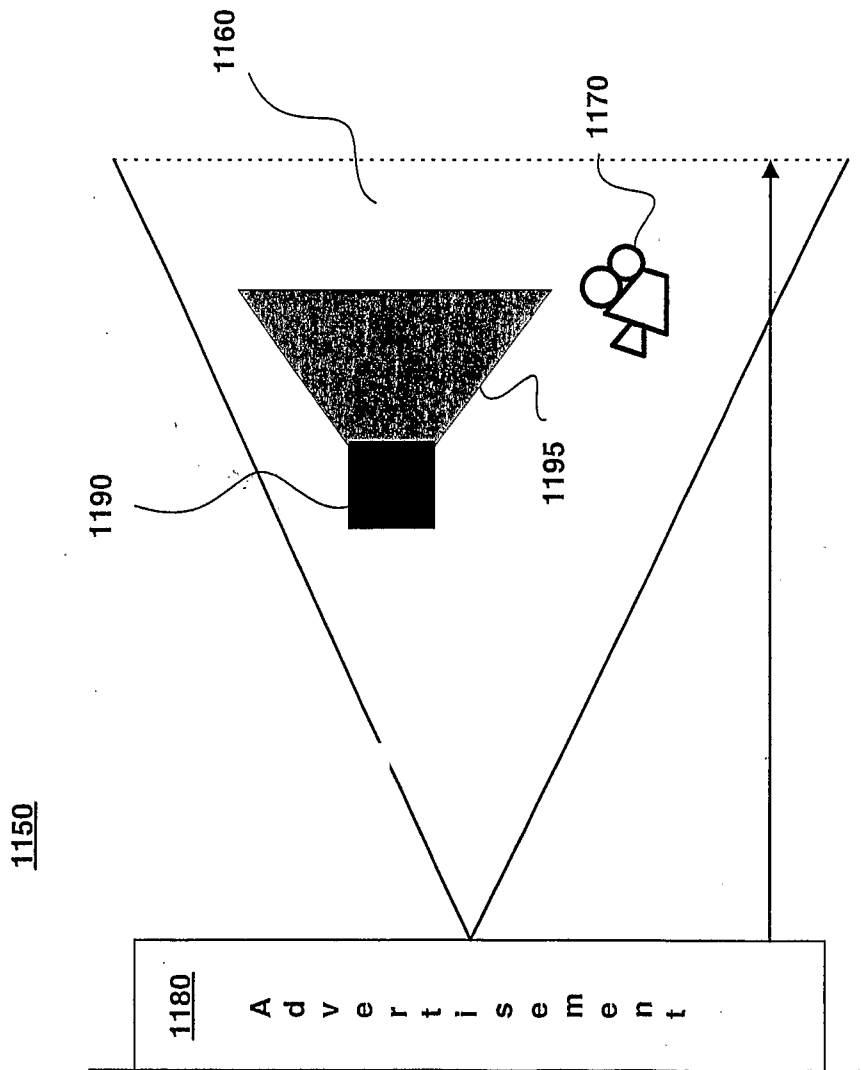

FIGURE 11B

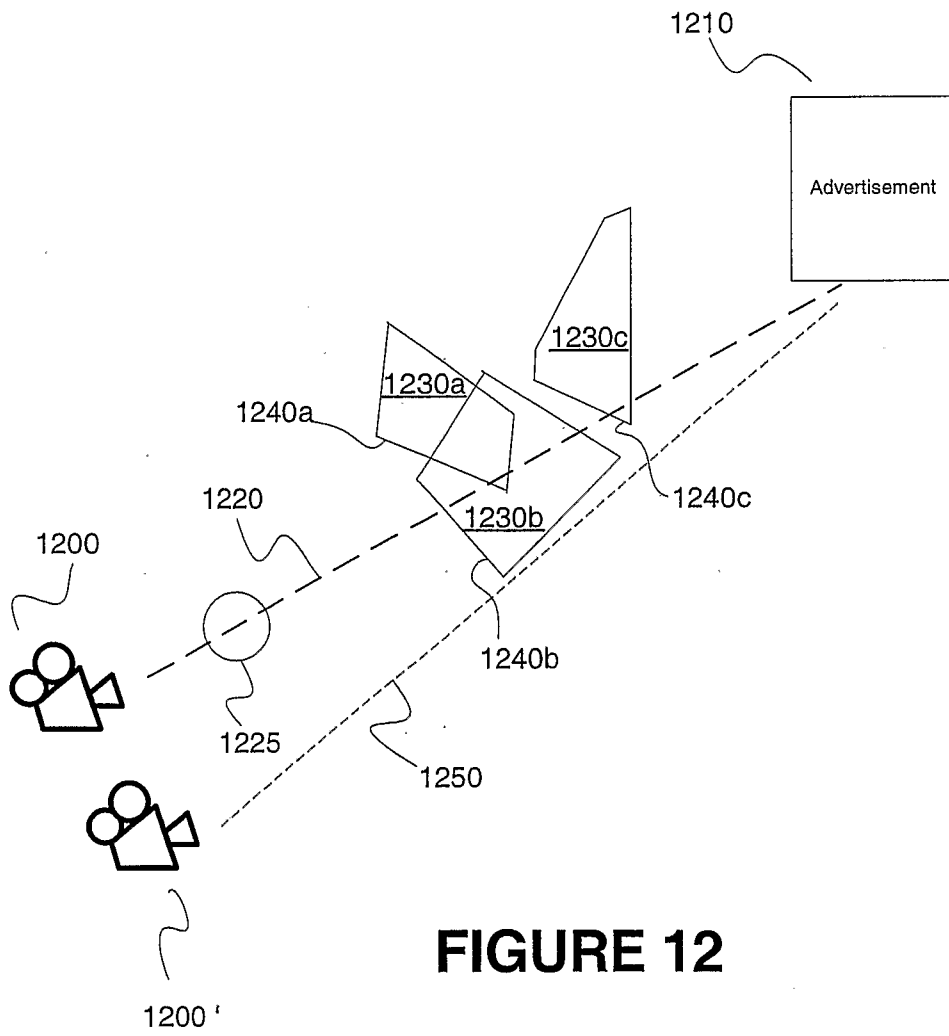

FIGURE 12

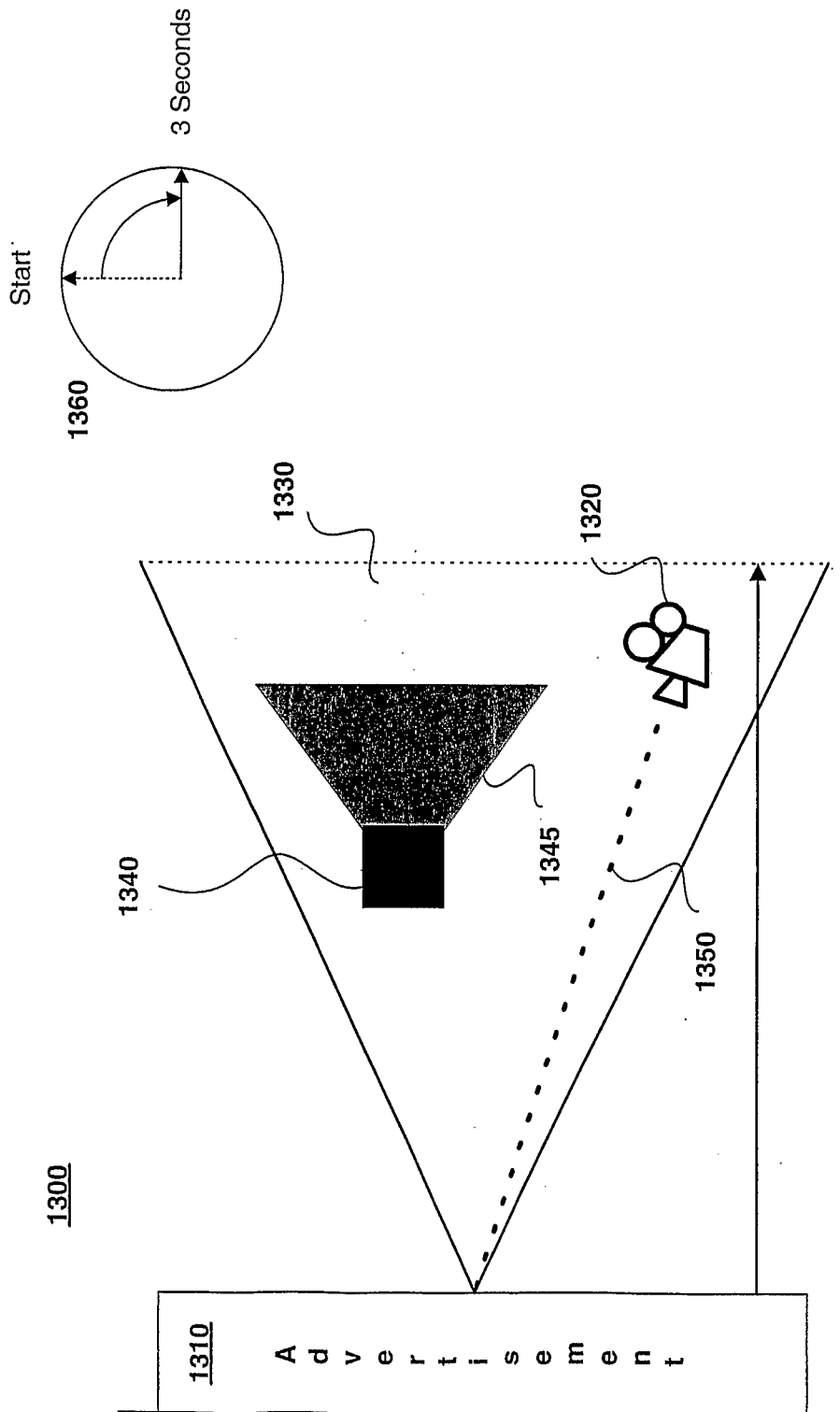

FIGURE 13A

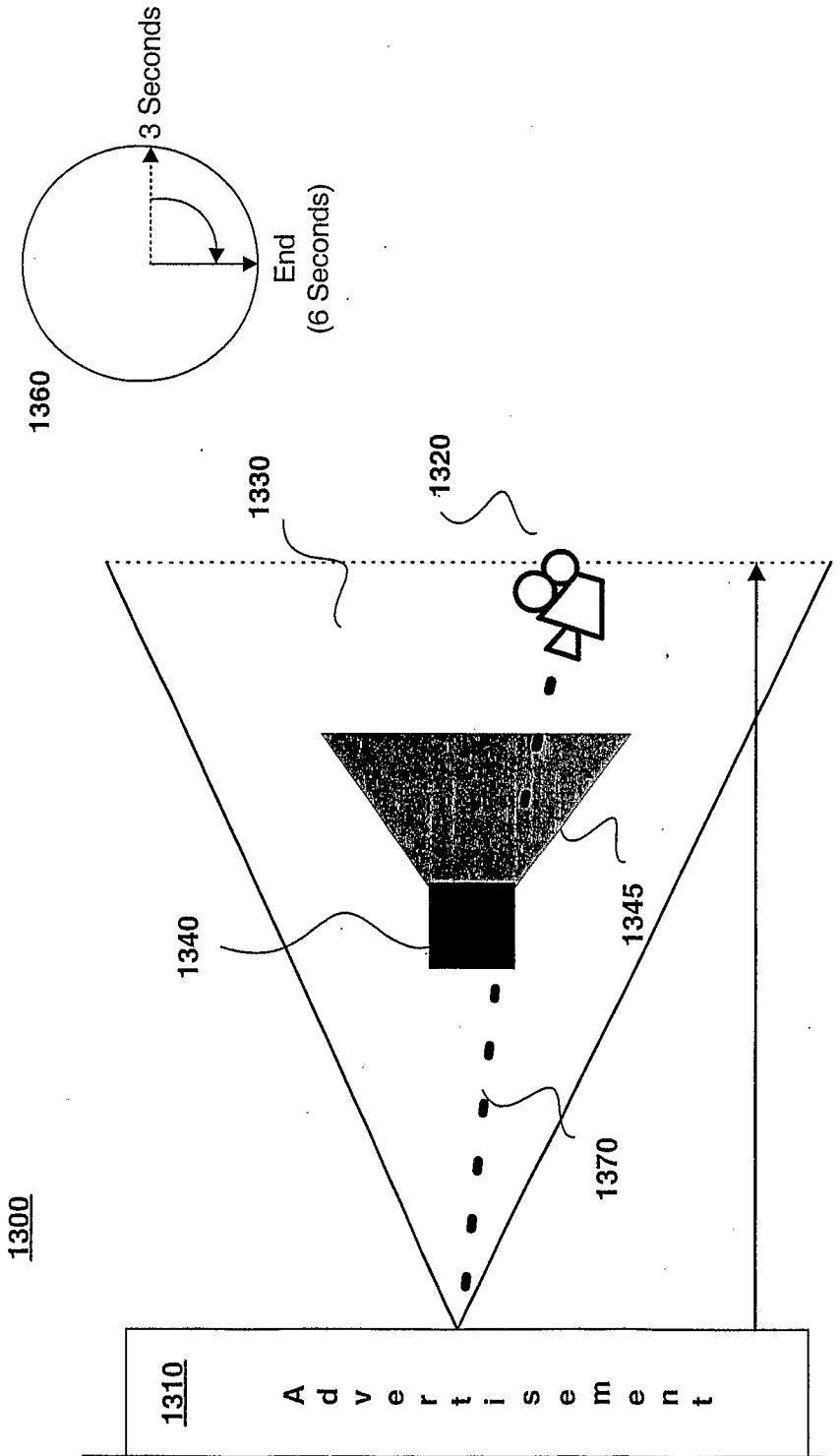

FIGURE 13B

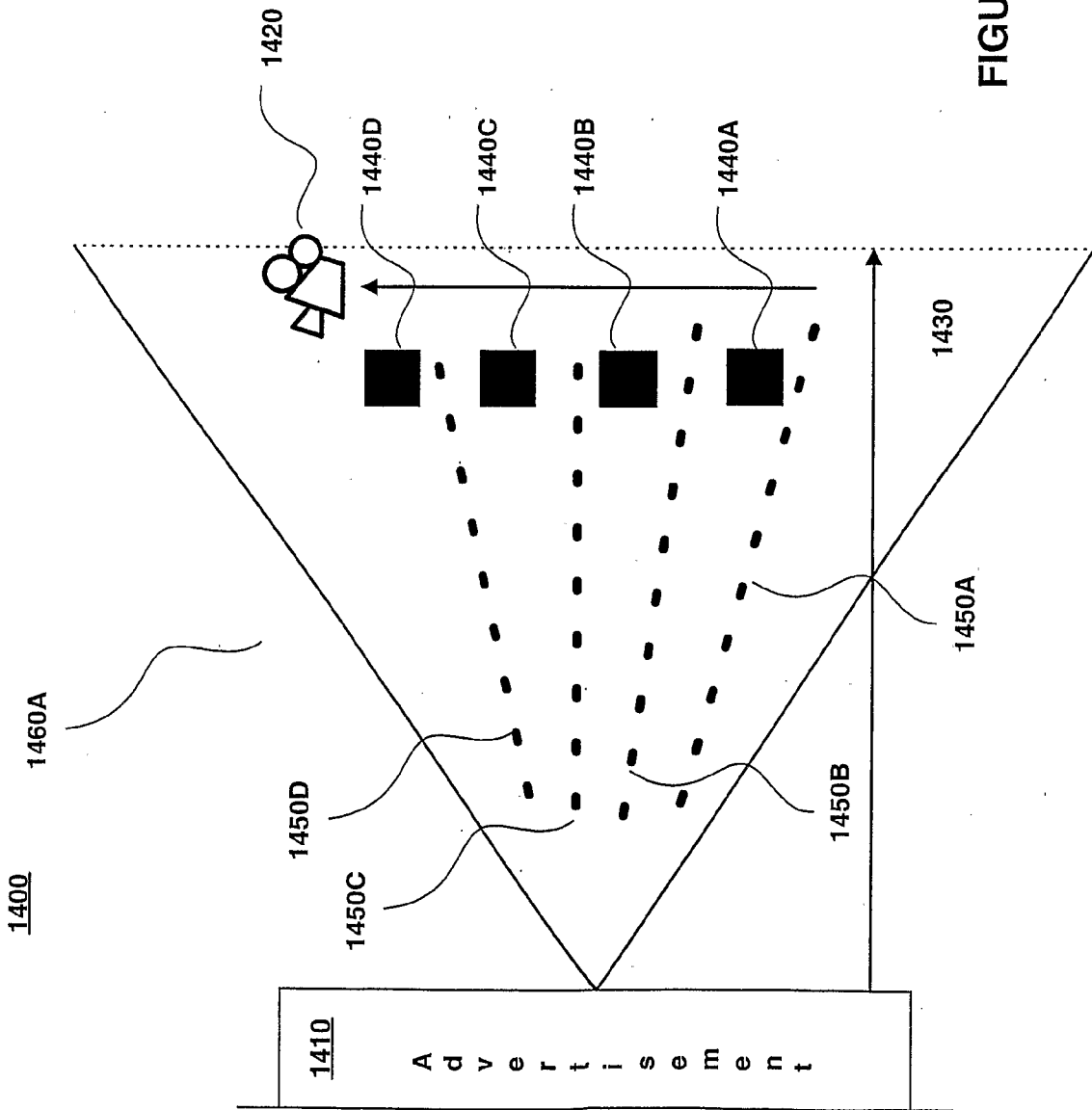

FIGURE 14