

Sept. 22, 1964

N. NORLIN

3,149,565

MECHANISM FOR CLAMPING FLEXIBLE PRINTING PLATES
TO THE CYLINDERS OF PRINTING MACHINES

Filed Feb. 11, 1963

2 Sheets-Sheet 1

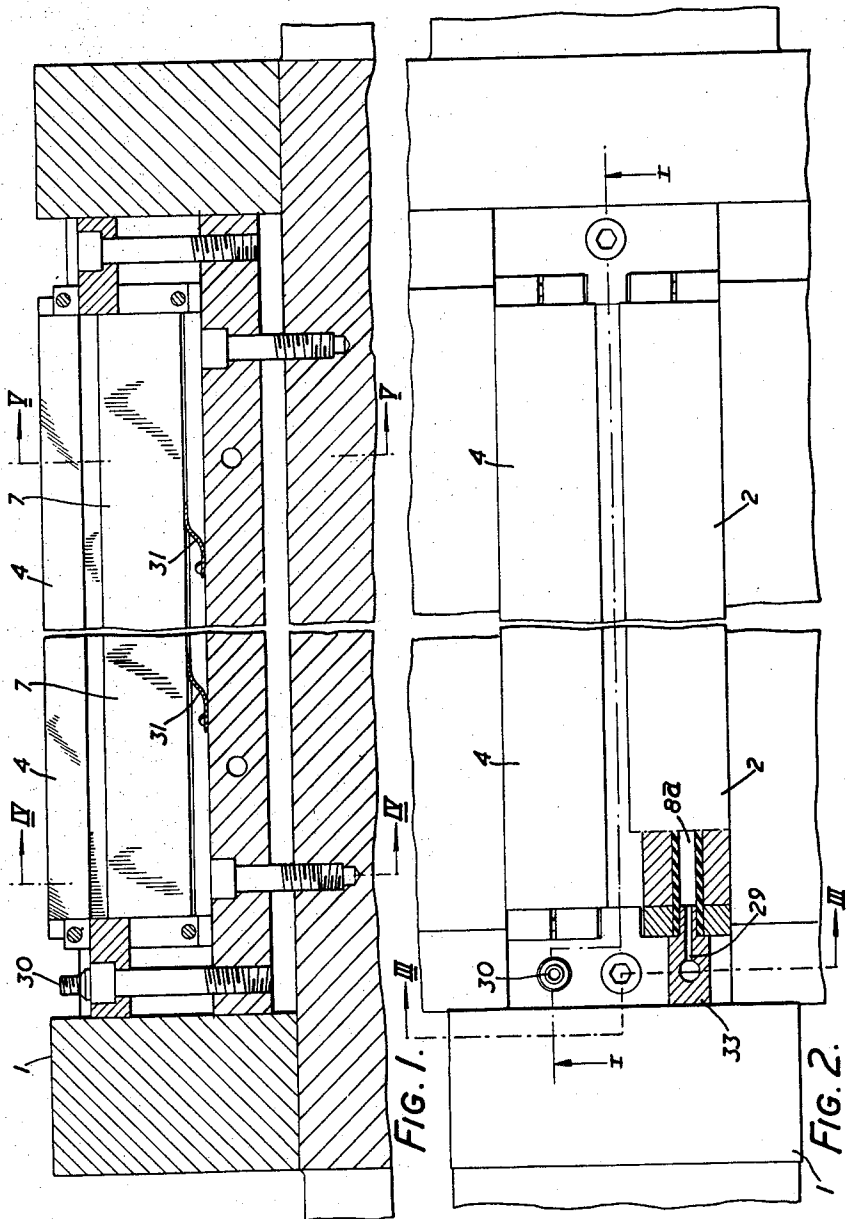

INVENTOR
Nils Norlin
BY *Baldwin & Wright*
ATTORNEYS

Sept. 22, 1964

N. NORLIN

3,149,565

MECHANISM FOR CLAMPING FLEXIBLE PRINTING PLATES
TO THE CYLINDERS OF PRINTING MACHINES

Filed Feb. 11, 1963

2 Sheets-Sheet 2

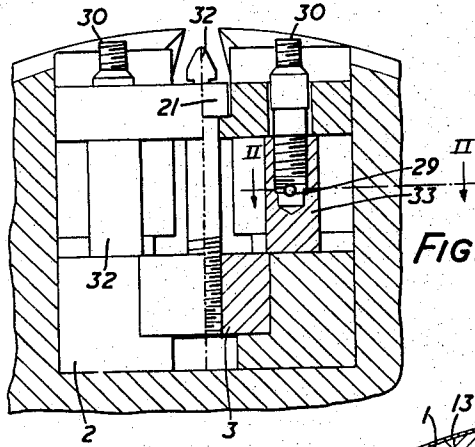

FIG. 3.

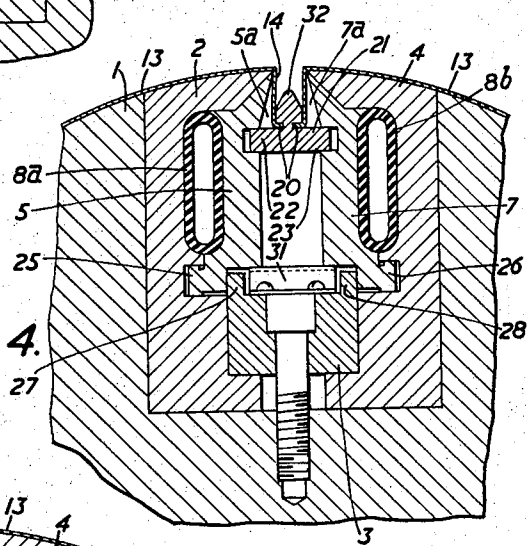

FIG. 4.

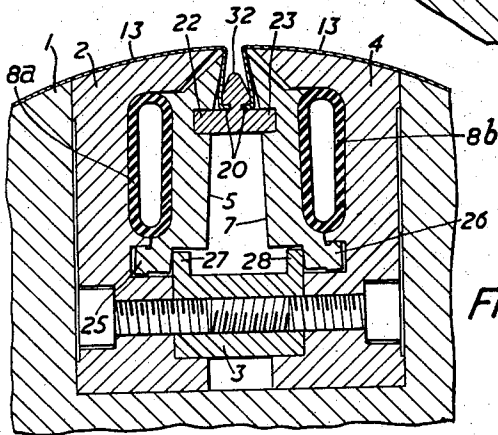

FIG. 5.

INVENTOR

Nils Norlin

BY

Baldwin & Hight

ATTORNEYS

1

3,149,565

MECHANISM FOR CLAMPING FLEXIBLE PRINTING PLATES TO THE CYLINDERS OF PRINTING MACHINES

Nils Norlin, Copenhagen, Denmark, assignor to Carl Allers Etablissement A/S

Filed Feb. 11, 1963, Ser. No. 257,698

Claims priority, application Great Britain Feb. 9, 1962

8 Claims. (Cl. 101—415.1)

This invention relates to printing machine cylinders and to means for securing a flexible printing plate to the periphery of such a cylinder.

According to the present invention a printing cylinder has fluid operable plate clamping components which can act independently on each end of a flexible printing plate to secure and tension it about the periphery of the cylinder. Thus the clamping components can be operated independently or together as may be found most convenient to obtaining a proper setting of the plate on the cylinder.

Preferably the fluid operable clamping components are housed in a slot in the periphery of the cylinder and each is movable to clamp one flanged end of the printing plate, and is displaceable to tension the plate about the cylinder.

In a preferred arrangement each of the plate clamping components is mounted for pivoting movement about its end which is displaced from the periphery of the cylinder.

Each of the plate clamping components may be operable by an inflatable flexible resilient device which may be located between each pivotable clamping component and the wall of the slot in the cylinder at a position between the point about which the clamping component can pivot and the periphery of the cylinder.

Each of the clamping components may also be arranged to cooperate with a longitudinally extending clamping element which is formed with grooves to receive out-turned lips formed on the ends of the flanges provided on each end of the printing plate with which it is to be used.

Preferably the clamping element is formed with an upstanding portion between which and one of the clamping components one of the flanges on the plate can be clamped.

In a convenient construction the clamping components are supported by the clamping element which is flanged at each side to enter grooves in the clamping components with freedom permitting them to rock in the pivotal movement about their ends displaced from the periphery of the cylinder. Moreover the ends of the clamping components displaced from the periphery of the cylinder may be provided with out-turned lugs which are arranged to enter recesses provided in the wall of the slot and to be disposed in gaps between these recesses and flanges provided on a central bar secured between the side walls of the slot, the lugs having sufficient freedom of movement in the spaces thus defined to rock in a pivoting movement.

The recesses may be formed in location members provided in the cylinder and which provide the walls to the slot, and the clamping components can be urged radially outwardly in the cylinder by means of springs acting between them and the central bar.

The invention may be formed in various ways but one embodiment will be described with reference to the accompanying drawings in which

FIGURE 1 is a longitudinal section on the line I—I of FIGURE 2,

FIGURE 2 is a plan view with a local section on the line II—II of FIGURE 3,

FIGURE 3 is a section on the line III—II of FIGURE 2,

2

FIGURE 4 is a section on the line IV—IV of FIGURE 1, and

FIGURE 5 is a section on the line V—V of FIGURE 1.

In the arrangement to be described the printing cylinder is indicated at 1, having in its periphery a longitudinal groove in which are secured location members in the form of bars 2, 3, 4 defining a longitudinal slot, in which are disposed plate-engaging parts in the form of clamping components 5, 7. The flexible printing plate is indicated at 13 having end flanges 14 which enter the longitudinal gap between the opposed faces 5^a, 7^a of the components 5, 7.

In the construction shown in the accompanying drawing the flanges 14 have out-turned lips at their inner ends which enter grooves 20 formed in a longitudinally extending clamping element 21 having lateral flanges 22, 23 which enter grooves formed in the clamping components 5, 7.

The clamping components 5, 7 are formed at their ends displaced from the periphery of the cylinder with out-turned lugs 25, 26 which slidably enter recesses formed in the opposed faces of the bars 2 and 4 and these lower ends are also formed to accommodate flanges 27, 28 upstanding from the central bar 3, the lugs 25 and 26 being disposed in gaps between the aforesaid recesses and the flanges 27 and 28.

Two inflatable resilient devices in the form of inflatable bags 8^a, 8^b are arranged to act and react between the side bars 2 and 4 and the clamping components 5, 7 respectively, these bags acting on the components 5, 7 between their outer ends and the lugs 25, 26 which can rock and slide to a limited extent in the recesses in the bars 2, 4.

Thus, when the bags 8^a, 8^b are inflated, the clamping components 5, 7 are caused to approach one another at their outer ends so as to clamp the flanges 14 of the printing plate 13 against the upstanding portion 32 of the clamping element 21 and at the same time to lock the flange lips in the grooves 20 in the clamping element component. The outer ends of the clamping components 5 and 7 extend out to engage the printing plate at the junctions of the flanges 14 and the circumferential part of the plate, and in the result therefore the action of inflation is not only to clamp the plate 13 but also to reduce the gap (formed in the printing surface) between the junctions.

In the construction shown the two inflatable bags are arranged to be inflated (and deflated) independently: for this purpose the two bags 8^a, 8^b are carried at one end of the cylinder by blocks 33 having air ducts 29 extending to inflation nipples 30.

The clamping components 5 and 7 are urged outwardly towards the periphery of the cylinder by springs 31 which act between the components themselves and the central bar 3.

While any gas or liquid under pressure could be used the applicant prefers to use air to inflate the bags in the embodiment as set forth.

I claim:

1. In combination, a printing cylinder provided in its periphery with a slot for receiving flanges extending inwardly from adjacent edges of a flexible printing plate applied to said cylinder and which flanges are formed with out-turned lips extending towards one another; two clamping components housed in said slot and mounted on said cylinder for pivoting movement about the ends of said clamping components which are displaced inwardly from the periphery of said cylinder; a longitudinally extending clamping element formed with grooves for receiving said plate flange lips; and two flexible resilient devices independently inflatable by

3

fluid pressure and being housed in said slot and respectively located between said clamping components and the walls of said slot at positions between the pivotal mountings of said clamping components and the periphery of said cylinder, said flexible resilient devices, when inflated, displacing said clamping components relatively to one another and to said clamping elements for clamping the flanged ends of the printing plate between said clamping components and said clamping element thereby to tension said printing plate.

2. A printing cylinder as claimed in claim 1 in which the clamping element is formed with an upstanding portion between which and one of the clamping components one of the flanges on the plate can be clamped.

3. A printing cylinder as claimed in claim 2 in which the clamping components are formed with grooves and the clamping element is flanged at each side to enter said grooves in the clamping components with freedom permitting said clamping components to rock in the pivotal movement about their ends displaced from the periphery of the cylinder.

4. A printing cylinder as claimed in claim 3 including a central bar having flanges within said slot and being secured between walls thereof, said slot walls being provided with recesses and there being gaps between said recesses and the central bar flanges, the ends of the clamping components displaced from the periphery of the cylinder being provided with out-turned lugs extending into said recesses and gaps, the lugs having sufficient freedom of movement in the spaces defined by said recesses and gaps to rock in a pivoting movement.

5. A printing cylinder as claimed in claim 4 including location members in the cylinder and which provide the walls to the slot, and in which said recesses are formed in said location members.

4

6. A printing cylinder as claimed in claim 5 including spring means between said central bar and said clamping components by which the clamping components are urged radially outwardly in the cylinder.

7. In combination, a printing cylinder provided in its periphery with a slot for receiving flanges at adjacent edges of a flexible printing plate applied to said cylinder; two clamping components housed in said slot and mounted on said cylinder for pivoting movement about the ends of said clamping components which are displaced inwardly from the periphery of the cylinder; a central bar having flanges within said slot and being secured between the walls thereof, walls of said slot being provided with recesses and there being gaps between said recesses and the central bar flanges, said ends of said clamping components which are displaced inwardly from the periphery of the cylinder being provided with out-turned lugs extending into said recesses and gaps, said lugs having sufficient freedom of movement in the spaces defined by said recesses and gaps to rock pivotally; and fluid pressure operable means for separately and independently moving said clamping components to clamping positions for clamping the flanged ends of said printing plate and tensioning said plate about said cylinder.

8. A printing cylinder as claimed in claim 7 including spring means between said central bar and said clamping components by which the clamping components are urged radially outwardly in the cylinder.

References Cited in the file of this patent

UNITED STATES PATENTS

2,768,579	Fies	Oct. 30, 1956
2,961,951	Nitchie	Nov. 29, 1960
3,058,417	Norlin	Oct. 16, 1962

35