

(12) STANDARD PATENT APPLICATION (11) Application No. AU 2016201079 A1
(19) AUSTRALIAN PATENT OFFICE

(54) Title
Winch

(51) International Patent Classification(s)
B66D 1/26 (2006.01) **B66D 1/22** (2006.01)
B66D 1/12 (2006.01)

(21) Application No: **2016201079** (22) Date of Filing: **2016.02.22**

(43) Publication Date: **2016.03.10**

(43) Publication Journal Date: **2016.03.10**

(62) Divisional of:
2013205829

(71) Applicant(s)
Warn Industries, Inc.

(72) Inventor(s)
Fretz, Darren G.;Averill, Bryan M.;Shuyler, Steven W.;Borntrager, Bryon M.;Hartelt, Kyle A.;Steele, Glenda M.

(74) Agent / Attorney
Shelston IP Pty Ltd., Level 21, 60 Margaret Street, Sydney, NSW, 2000

ABSTRACT

A winch includes a motor having a motor housing including a motor case and an integrated first drum support attached to the motor case for closing an end of the motor case. A gear reduction unit is drivingly attached to the motor and has a gear housing including a gear case and second drum support attached to the gear case. A tie plate is connected to the first and second drum supports. A control unit is removably mounted to the tie plate. A rotatable drum is supported by the first and second drum supports.

FIG. 1

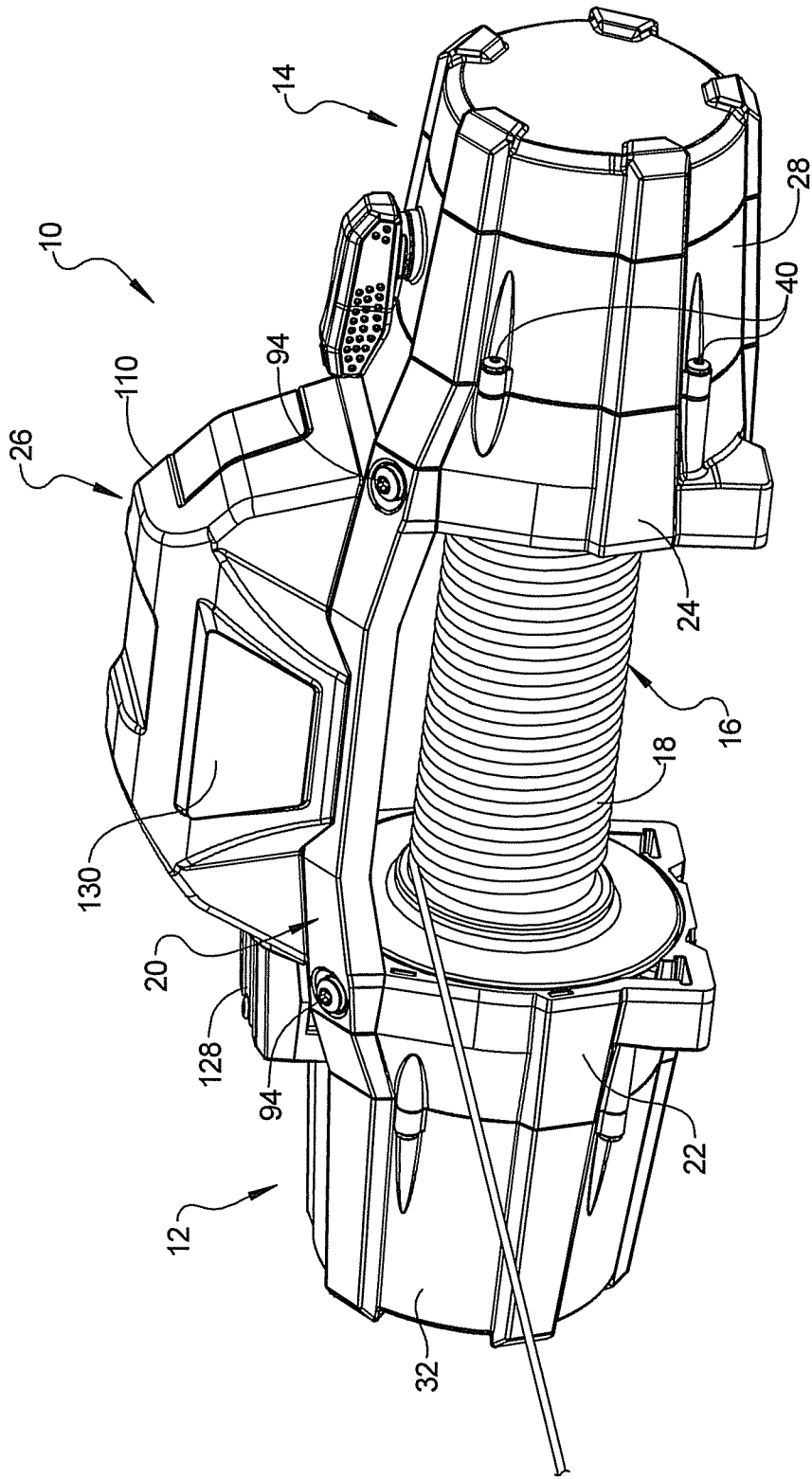

FIG 1

WINCH

CROSS-REFERENCE TO RELATED APPLICATIONS

[0001] This application is a divisional of Australian Patent Application No. 2013205829, the entire disclosure of which is incorporated herein by reference.

FIELD OF THE INVENTION

[0002] The present disclosure relates to a winch, and more particularly to improved assembly features for a winch.

BACKGROUND OF THE INVENTION

[0003] This section provides background information related to the present disclosure which is not necessarily prior art.

[0004] Winches are commonly made using a motor attached to a first drum support and a transmission attached to a second drum support with a rotatable drum disposed between the first and second drum supports. Tie rods are used for connection between the first and second drum support. The motor is typically a self-contained motor that is separate from the first drum supports. With these prior winch designs, the ornamental appearance and the structure of the winch was influenced by the appearance of the motor housing. Accordingly, it is desirable to provide a winch construction that is capable of being more aesthetically pleasing and that can include a low profile, improved sealing capability, alternative mounting arrangements for the controller and other assembly related improvements.

SUMMARY OF THE INVENTION

[0005] This section provides a general summary of the disclosure, and is not a comprehensive disclosure of its full scope or all of its features.

[0006] A winch is provided having a motor with a motor housing including a motor case and a first drum support attached to the motor case for closing an end of the motor case. The motor includes a brush holder assembly attached to the first drum support as well as an armature terminal and field terminals attached to the first drum support. The first drum support includes an insulator block for electrically isolating the armature terminal and the field terminals from the drum support. The armature terminal and the field terminals are linearly

aligned with one another to facilitate easy connection with a control unit. The motor includes an armature with a drive shaft and a brush plate disposed on a drive shaft side of the armature. The motor includes a flux ring clamped between the motor case and the first drum support and supported by a plurality of ribs which dissipate heat from the flux ring. The motor case and drum support can be made of aluminum to further improve heat dissipation. The motor also includes a brush plate having grounding screws that are connected to the first drum support.

[0007] A gear reduction unit is drivingly attached to the motor and has a gear housing including a gear case and a second drum support attached to the gear case for closing an end of the gear case. The gear case and the second drum support are shaped generally symmetric to the motor case and the first drum support in order to give the winch a generally symmetric appearance.

[0008] A tie plate can be used to connect the first and second drum supports. The tie plate includes four corners with a mounting aperture in each of the four corners, each mounting aperture being aligned with one of a plurality of threaded bores in one of the first and second drum supports. The plurality of threaded bores each have a central axis that intersects an axis of rotation of the motor. A rotatable drum is drivingly connected to the motor and supported by the first and second drum supports.

[0009] A control unit can be mounted to the tie plate and can be removable so that it can optionally be mounted to another portion of a vehicle. The control unit can be electrically connected to the armature terminal and the field terminals by motor leads. A cover plate can be provided for covering the motor leads. The control unit can include a base plate detachably mounted to the tie plate. A contactor is mounted to the base plate in communication with the motor leads and a remote connector is mounted to the base plate and in communication with the contactor.

[0010] Further areas of applicability will become apparent from the description provided herein. The description and specific examples in this summary are intended for purposes of illustration only and are not intended to limit the scope of the present disclosure.

BRIEF DESCRIPTION OF THE DRAWINGS

[0011] The drawings described herein are for illustrative purposes only of selected embodiments and not all possible implementations, and are not intended to limit the scope of the present disclosure.

[0012] Figure 1 is a perspective view of a winch according to the principles of the present disclosure;

[0013] Figure 2 is a perspective view of the winch of Figure 1 with the control unit removed for mounting at a remote location;

[0014] Figure 3 is a perspective view of a tie plate for the winch according to the principles of the present disclosure;

[0015] Figure 4 is a perspective view of the motor assembly according to the principles of the present disclosure;

[0016] Figure 5 is a cross-sectional view of the motor assembly shown in Figure 4;

[0017] Figure 6 is an exploded perspective view of the motor assembly according to the principles of the present disclosure;

[0018] Figure 7 is a perspective view of a drum support portion of the motor assembly according to the principles of the present disclosure;

[0019] Figure 8 is an end view of the drum support shown in Figure 7;

[0020] Figure 9 is a perspective view of a top portion of a terminal isolator according to the principles of the present disclosure;

[0021] Figure 10 is a perspective view of a bottom portion of the terminal isolator according to the principles of the present disclosure;

[0022] Figure 11 is a perspective view of a control unit according to the principles of the present disclosure;

[0023] Figure 12 is a similar perspective view of the control unit as shown in Figure 11 with an added terminal cover;

[0024] Figure 13 is a perspective view of the control unit assembly with the cover removed according to the principles of the present disclosure;

[0025] Figure 14 is a perspective view of the winch having a rope cover mounted thereto according to the principles of the present disclosure; and

[0026] Figure 15 is a perspective view of the winch with an alternative rope cover removed for illustrative purposes.

[0027] Corresponding reference numerals indicate corresponding parts throughout the several views of the drawings.

DETAILED DESCRIPTION OF THE INVENTION

[0028] Example embodiments will now be described more fully with reference to the accompanying drawings.

[0029] Example embodiments are provided so that this disclosure will be thorough, and will fully convey the scope to those who are skilled in the art. Numerous specific details are set forth such as examples of specific components, devices, and methods, to provide a thorough understanding of embodiments of the present disclosure. It will be apparent to those skilled in the art that specific details need not be employed, that example embodiments may be embodied in many different forms and that neither should be construed to limit the scope of the disclosure. In some example embodiments, well-known processes, well-known device structures, and well-known technologies are not described in detail.

[0030] The terminology used herein is for the purpose of describing particular example embodiments only and is not intended to be limiting. As used herein, the singular forms "a," "an," and "the" may be intended to include the plural forms as well, unless the context clearly indicates otherwise. The terms "comprises," "comprising," "including," and "having," are inclusive and therefore specify the presence of stated features, integers, steps, operations, elements, and/or components, but do not preclude the presence or addition of one or more other features, integers, steps, operations, elements, components, and/or groups thereof. The method steps, processes, and operations described herein are not to be construed as

necessarily requiring their performance in the particular order discussed or illustrated, unless specifically identified as an order of performance. It is also to be understood that additional or alternative steps may be employed.

[0031] When an element or layer is referred to as being "on," "engaged to," "connected to," or "coupled to" another element or layer, it may be directly on, engaged, connected or coupled to the other element or layer, or intervening elements or layers may be present. In contrast, when an element is referred to as being "directly on," "directly engaged to," "directly connected to," or "directly coupled to" another element or layer, there may be no intervening elements or layers present. Other words used to describe the relationship between elements should be interpreted in a like fashion (e.g., "between" versus "directly between," "adjacent" versus "directly adjacent," etc.). As used herein, the term "and/or" includes any and all combinations of one or more of the associated listed items.

[0032] Although the terms first, second, third, etc. may be used herein to describe various elements, components, regions, layers and/or sections, these elements, components, regions, layers and/or sections should not be limited by these terms. These terms may be only used to distinguish one element, component, region, layer or section from another region, layer or section. Terms such as "first," "second," and other numerical terms when used herein do not imply a sequence or order unless clearly indicated by the context. Thus, a first element, component, region, layer or section discussed below could be termed a second element, component, region, layer or section without departing from the teachings of the example embodiments.

[0033] Spatially relative terms, such as "inner," "outer," "beneath," "below," "lower," "above," "upper," and the like, may be used herein for ease of description to describe one element or feature's relationship to another element(s) or feature(s) as illustrated in the figures. Spatially relative terms may be intended to encompass different orientations of the device in use or operation in addition to the orientation depicted in the figures. For example, if the device in the figures is turned over, elements described as "below" or "beneath" other elements or features would then be oriented "above" the other elements or features. Thus, the example term "below" can encompass both an orientation of above and below. The device may be otherwise oriented (rotated 90 degrees or at other orientations) and the spatially relative descriptors used herein interpreted accordingly.

[0034] With reference to Figure 1, a winch 10 according to the principles of the present disclosure will now be described. The winch 10 includes a motor assembly 12 drivingly

connected to a gear reduction unit 14 which provides driving torque to a rotatable drum 16. A cable 18 can be wound onto, or off from, the rotatable drum 16 to provide various pulling operations. A tie plate 20 can be disposed for connection between a first drum support 22 of the motor assembly 12 and a second drum support 24 of the gear reduction unit 14. A control unit 26 can be removably mounted to the tie plate 20. The first drum support 22 is integrated with the motor assembly 12 in that it supports components of the motor and encloses the open end of the motor case 32, while also providing a bearing support structure for rotatably supporting the rotatable drum 16. Similarly, the second drum support 24 is integrated into the gear housing by supporting components of the gear reduction unit, and enclosing an open end of other gear case 28 while providing a bearing support structure for rotatably supporting the rotatable drum 16.

[0035] Figure 2 illustrates the winch 10 with the control unit 26 removed for providing the winch 10 with a lower profile, and the winch control unit 26 can be mounted to alternative surfaces of a vehicle such as the bumper, fender, or other interior or exterior surfaces of the vehicle with cables being provided for connecting the control unit 26 to the motor terminals.

[0036] With reference to Figures 4-10, the motor assembly 12 will now be described. The motor assembly 12 includes a housing 30 including a motor case 32 and the first drum support 22. The motor case 32 includes mounting bosses 36 and the first drum support includes corresponding mounting bosses 38. The mounting bosses 36, 38 each receive a fastener 40 for securing the motor case 32 to the first drum support 22. The gear unit case 28 and second drum support 24 can be assembled in a similar manner. A gasket 42, as shown in Figure 6, can be disposed between the motor case 32 and the first drum support 22 to provide a sealed connection therebetween.

[0037] With further reference to Figure 6, the motor assembly 12 includes an armature 44 rotatably supported within the motor case 32 by a bearing assembly 46 and rotatably supported by the first drum support 22 by a bearing assembly 48. A brush plate assembly 50 includes a brush plate 52 that supports a plurality of brushes 54 in contact with the armature 44. The brush plate assembly 50 is provided with a brush plate terminal 56 which is supported by the first drum support 22. The brush plate 52 can be mounted to the first drum support 22 by a plurality of grounding screws 58.

[0038] A field coil assembly 60 surrounds the armature 44 and includes field coil terminals 62, 64 which are also supported by the first drum support 22. The field coil assembly 60 is supported by a field coil flux ring 66 which is clamped between the motor case 32 and the

first drum support 22. The field coil flux ring 66 can be supported by a plurality of ribs 68 extending from the first drum support 22 as well as internal ribs 70 (best shown in Figure 5) of the motor case 32. Each of the field coils 60a-60d of the field coil assembly 60 is mounted to the field coil flux ring 66 by a corresponding fastener 72 so as to be supported in close proximity to the armature 44. The ribs 68 in the first drum support 22 protrude into the motor case 32 to create a secondary wall construction within the motor case 32 adding both rigidity and noise reduction. The motor case 32 can be made from aluminum, and the internal ribs 70, as well as the aluminum material that supports the field coil flux ring 66 and field coil assembly 60, allow for significantly improved heat dissipation from the coil assembly 60 into the motor case 32.

[0039] The field coil terminals 62, 64, as well as the brush plate terminal 56, are each disposed within the first drum support 22 and are electrically isolated therefrom by a bottom isolator 76 and a top isolator 78 which are shown in greater detail in Figures 10 and 9, respectively. A plurality of lock washers 80 and threaded nuts 82 are provided for securing the terminals 56, 62 and 64 to the isolators 76, 78. A plurality of O-rings 84 surround the terminals 56, 62, 64 between the top and bottom isolators 78, 76 to provide a seal around each terminal. As shown in Figure 8, the first drum support 22 also includes a screw boss 85 for receiving a fastener 86 for connecting a battery ground cable 87 thereto.

[0040] As best shown in Figure 7, the first drum support 22 supports the brush plate assembly 50 therein. The outer surface of the first and second drum supports 22, 24 are provided with a recessed region 90 that is designed to receive the tie plate 20 therein. The recessed region 90 includes an upper flat region 90a and two angled side portions 90b each including a mounting aperture 92 therein for receiving a threaded fastener 94 as best shown in Figures 1 and 2. The threaded apertures 92 can be aligned so as to intersect the rotational axis of the armature 44 and therefore provides good vertical and lateral support to the interconnection between the drum support 22 and tie plate 20.

[0041] With reference to Figure 3, the tie plate 20 includes a pair of elongated side rails 100 and a pair of connecting cross rails 102 that can define a central opening 104 therein. The cross rails 102 can be generally planar so as to lie flat against the flat portion 90a of the recesses 90 in the first and second drum supports 22, 24 which are part of the motor assembly 12 and gear reduction unit 14. The elongated side rails 100 can be angled relative to the cross bars 102 and include mounting apertures 106 at each end thereof that align with the threaded apertures 92 provided in the drum support 22 and receive the fasteners 94

therein. The tie plate 20 further includes a plurality of mounting apertures 108 that receive threaded fasteners (not shown) for securing the control unit 26 to the tie plate 20.

[0042] With reference to Figures 11-13, the control unit 26 will now be described in further detail. As shown in Figure 11, the control unit 26 includes a cover 110. As illustrated in Figure 13, the control unit 26 includes a base plate 112 which supports a contactor 114 which can be of any known electrical contactor type such as solenoids, mosfets, or other types of known contactors. A remote connector 116 can be provided on the base plate 112 to allow a remote cable unit to be connected for activating the contactor 114. A power cable 118 is connected to the contactor 114 and a plurality of motor leads 120, 122, 124 are also provided in contact with the contactor 114. The motor leads 120, 122, and 124 serve as bus bars that connect the control unit 26 to the motor terminals 56, 62, 64. The motor leads 120, 122, 124, as well as the motor terminals 56, 62, 64, can be covered by an auxiliary cover 128, as best shown in Figure 12. As an alternative configuration, the control unit 26 can be removed from the tie plate 20 and mounted to an alternative portion of a vehicle, such as a bumper, fender, or other external or internal compartment of the vehicle, in order to provide a winch having a lower profile, as illustrated in Figure 2. In the case where the control unit 26 is mounted in a different location, the motor leads 120, 122, 124 can be replaced with cables that provide connections between the remotely located control unit 26 and the motor terminals 56, 62, 64.

[0043] The cover 110 of the control unit 26 is provided with a branding 130 such as the company or product name or a logo and the tie plate 20 also includes a branding 132. When the control unit 26 is assembled to the tie plate 20, the cover 110 has a protruding portion 134 that extends over top of the branding 132 on the tie plate 20, as shown in Figure 12. When the control unit 26 is removed, the branding 132 on the tie plate 20 is then exposed so that there is always a branding 130 or 132 visible regardless of whether the control unit 26 is assembled to the tie plate or not.

[0044] In operation, a remote control unit connected to the remote connector 116 can be used to provide control signals to the contactor 114 for providing current to the motor assembly 12 to spool in or spool out the cable 18 from the drum 16. The winch 10 can be provided with a brake mechanism interior or exterior to the drum 16, and the gear reduction unit 14 can include multiple planetary gear sets, as is generally known in the art.

[0045] As illustrated in Figures 14 and 15, a rope cover 140 can be mounted to the front of the winch 10 when the winch 10 is not in use to shield the rope or cable and the drum from

UV light and debris that can degrade the rope or cable. The rope cover 140 can also have a refined appearance to enhance the appearance of the winch 10 when it is not in use. The rope cover 140 has a plate-like structure and can include a branding 142, as shown in Figure 14. As an alternative, as shown in Figure 15, the cover plate 140 can have alternative features such as ribs, slots, louvers, openings, or other features to give a refined appearance. The rope cover 140 further includes retention features 144 that engage corresponding retention features 146 provided on the first and second drum supports 22, 24 and/or the tie plate 20. Although they can take on various other forms, the retention features 144, 146 are shown as protrusions or fingers 144 and recesses or slots 146. The protrusions or fingers 144 can extend from edges of the rope cover 140 and the recesses or slots 146 can be provided in the surface of the drum supports 22, 24 and the tie plate 20. The protrusions or fingers 144 can be snapped into the recesses or slots 146 for retaining the rope cover 140 in place on the winch 10.

[0046] The foregoing description of the embodiments has been provided for purposes of illustration and description. It is not intended to be exhaustive or to limit the disclosure. Individual elements or features of a particular embodiment are generally not limited to that particular embodiment, but, where applicable, are interchangeable and can be used in a selected embodiment, even if not specifically shown or described. The same may also be varied in many ways. Such variations are not to be regarded as a departure from the disclosure, and all such modifications are intended to be included within the scope of the disclosure.

CLAIMS

1. A winch, comprising:
 - a motor having a motor housing including a motor case and a first drum support attached to said motor case for closing an end of said motor case;
 - a gear reduction unit drivingly attached to said motor and having a gear housing including a gear case and a second drum support attached to said gear case for closing an end of said gear case;
 - a tie plate connecting said first and second drum supports; and
 - a rotatable drum drivingly connected to said motor and supported by said first and second drum supports.
2. The winch according to claim 1, wherein said gear case and said second drum support are shaped generally symmetric to said motor case and said first drum support.
3. The winch according to claim 1, wherein said tie plate includes four corners with a mounting aperture in each of said corners, each mounting aperture being aligned with one of a plurality of threaded bores in one of said first and second drum supports, said plurality of threaded bores each having a central axis that intersect an axis of rotation of said motor.
4. The winch according to claim 1, further comprising a control unit mounted to said tie plate.
5. The winch according to claim 1, wherein said control unit includes a base plate detachably mounted to said tie plate, a contactor mounted to said base plate in communication with leads of said motor, and a remote connector mounted to said base plate and in communication with said contactor.
6. A winch, comprising:
 - a motor having a motor housing including a motor case and a first drum support attached to said motor case for closing an end of said motor case, said motor including a brush holder assembly attached to said first drum support;
 - a gear reduction unit drivingly attached to said motor; and
 - a rotatable drum drivingly connected to said motor and supported by said first and second drum supports.

7. The winch according to claim 6, wherein a ground terminal is connected to said first drum support.
8. The winch according to claim 6, wherein said drum support includes a plurality of ribs that protrude into an interior of the motor case.
9. A winch, comprising:
 - a motor having a motor housing including a motor case and a first drum support attached to said motor case for closing an end of said motor case, said motor including an armature terminal and field terminals attached to said first drum support; and
 - a rotatable drum drivingly connected to said motor and supported by said first drum support and a second drum support.
10. The winch according to claim 9, wherein said first drum support includes an insulation block for electrically isolating said armature terminal and said field terminals from said first drum support.
11. The winch according to claim 9, said armature terminal and said field terminals being linearly aligned with one another.
12. The winch according to claim 9, said motor including an armature with a drive shaft and a brush plate disposed on a drive shaft side of said armature.
13. A winch, comprising:
 - a motor having a motor housing including a motor case and a first drum support attached to said motor case for closing an end of said motor case, said motor including a flux ring clamped between said motor case and said first drum support and supported by a plurality of ribs; and
 - a rotatable drum drivingly connected to said motor.
14. The winch according to claim 13, wherein said motor case and said drum support are made of aluminum.
15. A winch, comprising:
 - a motor having a motor housing including a motor case and a drum support attached to said motor housing for closing an end of said motor housing, said motor including a brush plate having grounding screws threaded into said drum support;

a rotatable drum drivingly connected to said motor and supported by said drum support.

16. A winch, comprising:

a motor having a motor housing including a motor case and a first drum support attached to said motor housing, said first drum support including a screw boss for receiving a fastener for connecting a ground cable to the first drum support.

17. A winch, comprising:

a motor having a motor housing including a motor case and a first drum support attached to said motor case for closing an end of said motor case;

a gear reduction unit drivingly attached to said motor and having a gear housing including a gear case and a second drum support attached to said gear case for closing an end of said gear case, wherein said gear case and said second drum support are shaped generally symmetric to said motor case and said first drum support;

a rotatable drum drivingly connected to said motor and supported by said first and second drum supports.

18. The winch according to claim 17, further comprising a tie plate connecting said first and second drum supports.

19. The winch according to claim 18, wherein said tie plate includes four corners with a mounting aperture in each of said corners, each mounting aperture being aligned with one of a plurality of threaded bores in one of said first and second drum supports.

20. The winch according to claim 19, wherein said plurality of threaded bores each have a central axis that intersect an axis of rotation of said motor.

21. A winch, comprising:

a motor;

a gear reduction unit drivingly attached to said motor;

a tie plate connecting said first and second drum supports;

a control unit mounted to said tie plate; and

a rotatable drum drivingly connected to said motor.

22. The winch according to claim 21, wherein said control unit is electrically connected to an armature terminal and field terminals of said motor by bus bar straps.

23. The winch according to claim 22, wherein said control unit includes a cover plate covering said bus bar straps.

24. The winch according to claim 21, wherein said control unit includes a base plate detachably mounted to said tie plate, a contactor mounted to said base plate in communication with said motor leads, and a remote connector mounted to said base plate and in communication with said contactor.

25. The winch according to claim 21, wherein said tie plate includes a first branding thereon and said control unit includes a cover having a second branding thereon, wherein said control unit covers said first branding when the control unit is mounted to said tie plate, and when said control unit is removed from said tie plate the first branding on the tie plate is exposed.

26. A winch, comprising:
a motor and a first drum support attached to said motor;
a gear case and a second drum support attached to said gear case, said gear case housing a gear assembly drivingly connected to said motor;
a drum drivingly connected to said gear assembly between said first and second drum support; and
a rope cover removably attached in front of said drum.

27. The winch according to claim 26, wherein said rope cover includes a retention feature connected to a corresponding retention feature on one of said first and second drum supports.

28. The winch according to claim 26, further comprising a tie structure extending between said first and second drum supports, said rope cover including a retention feature connected to a corresponding retention feature on said tie structure.

29. The winch according to claim 26, wherein said rope cover includes a branding thereon.

30. The winch according to claim 26, wherein said rope cover includes at least one opening therein.

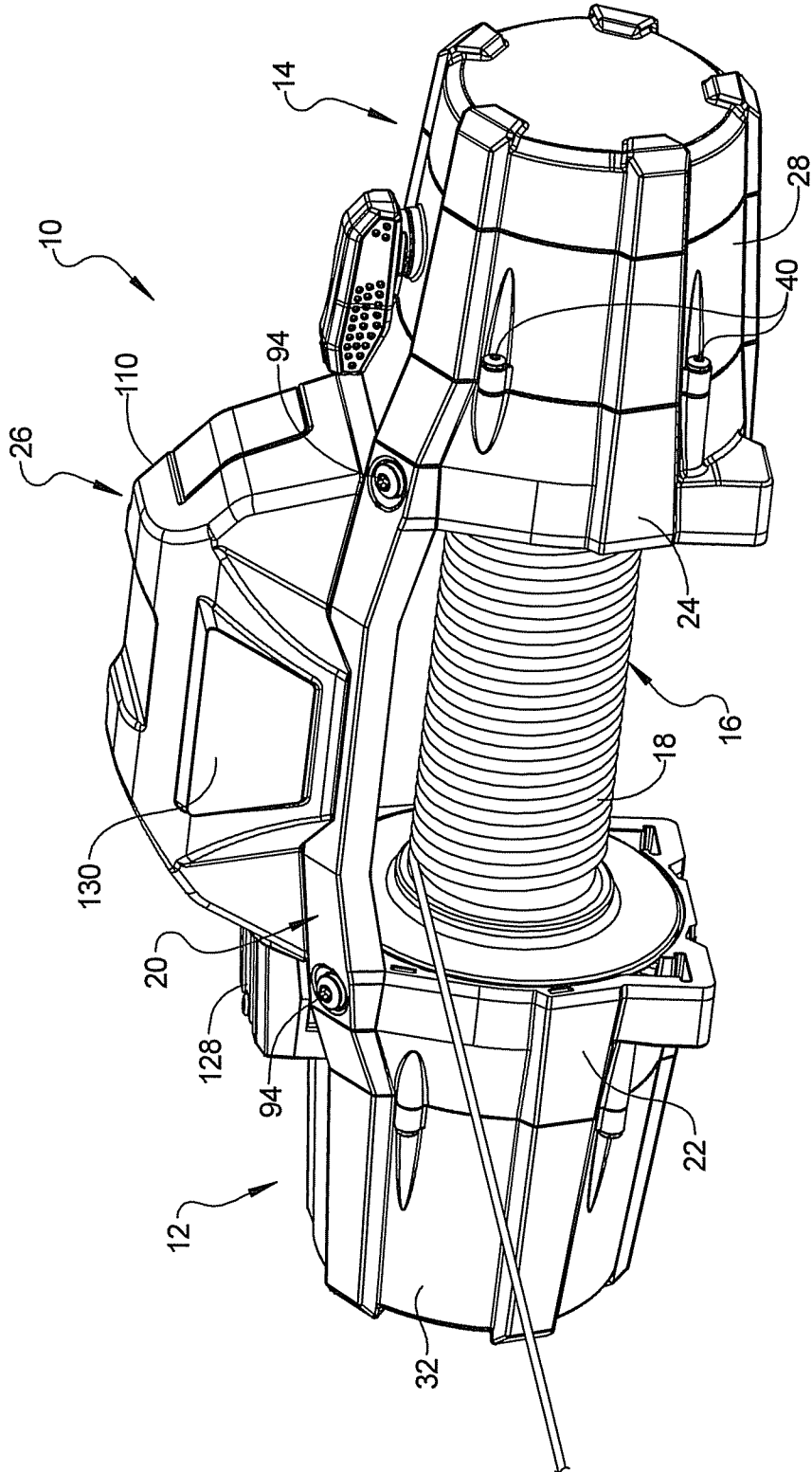

FIG 1

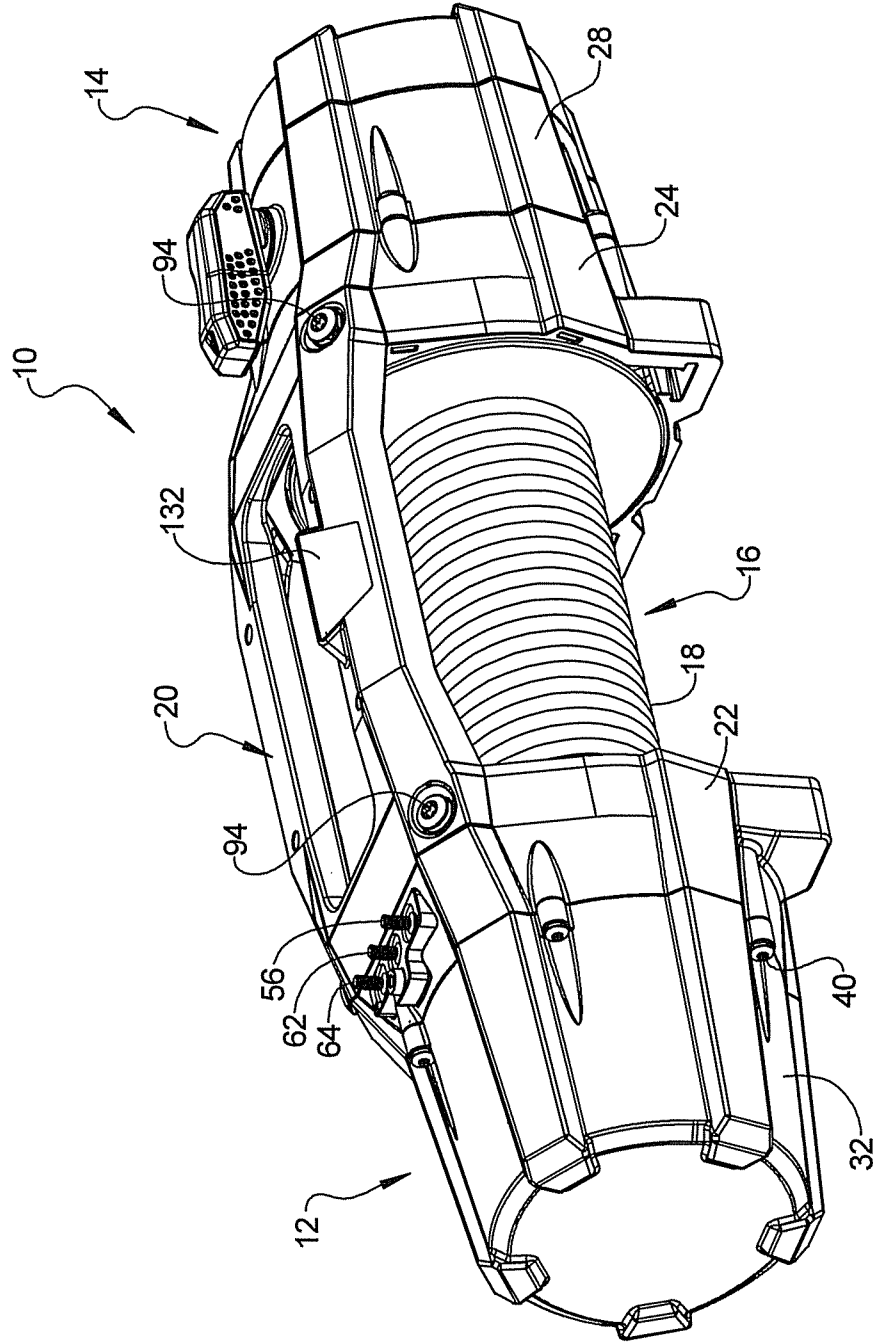

FIG 2

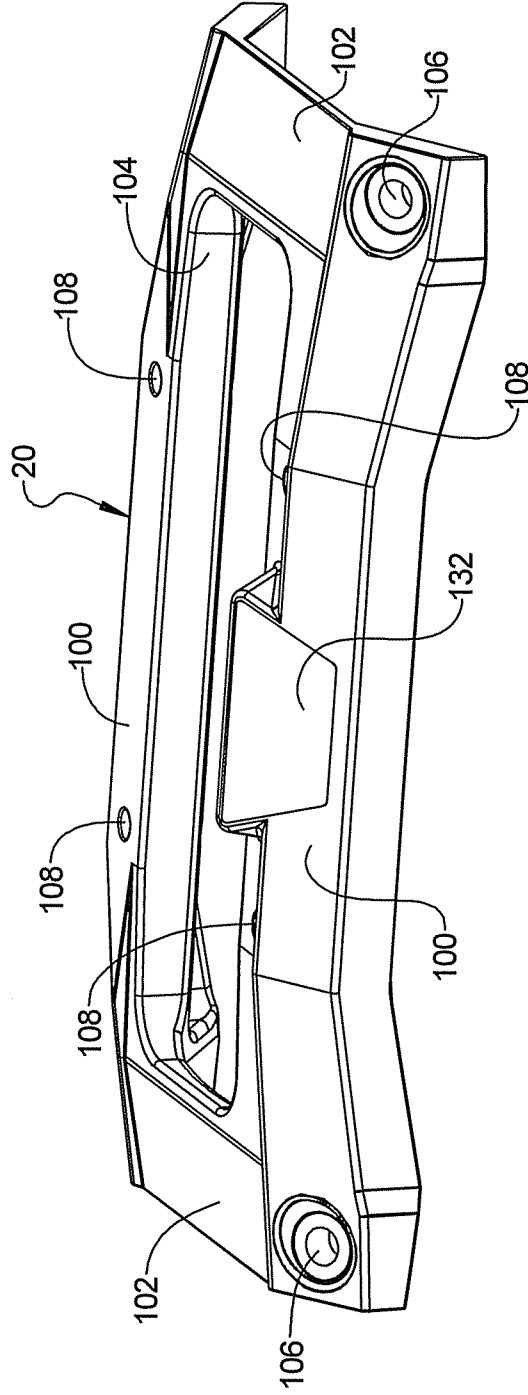

FIG 3

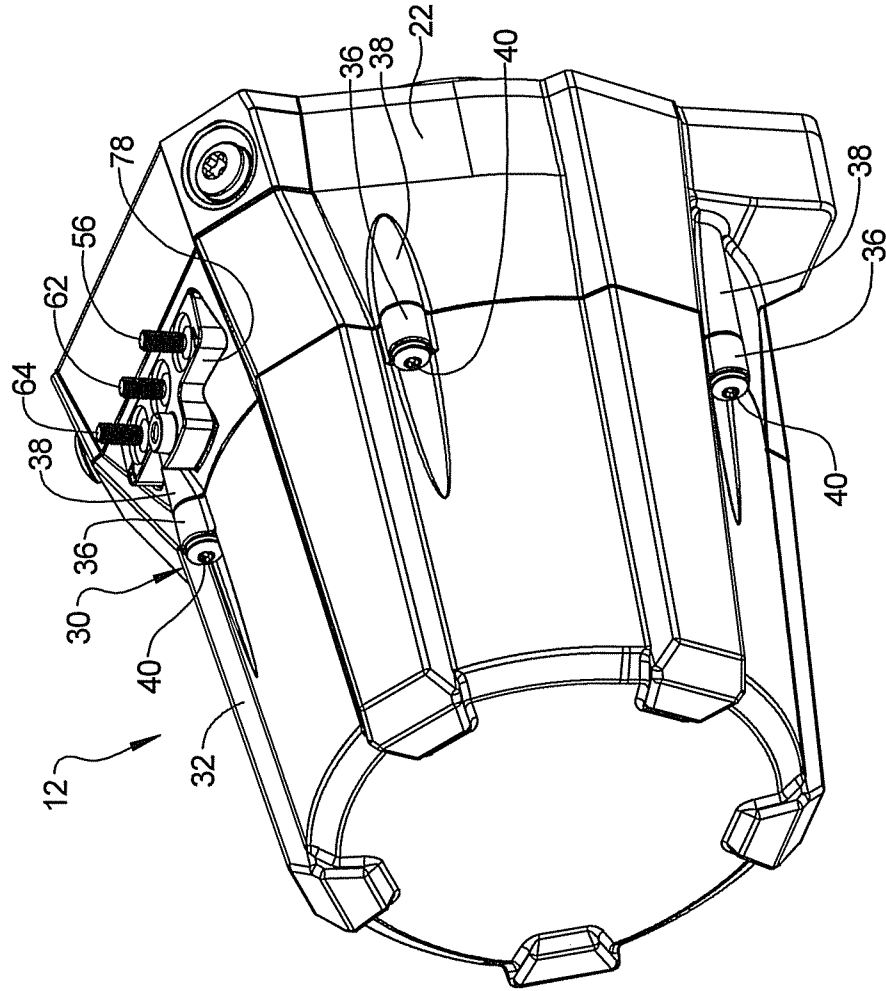

FIG 4

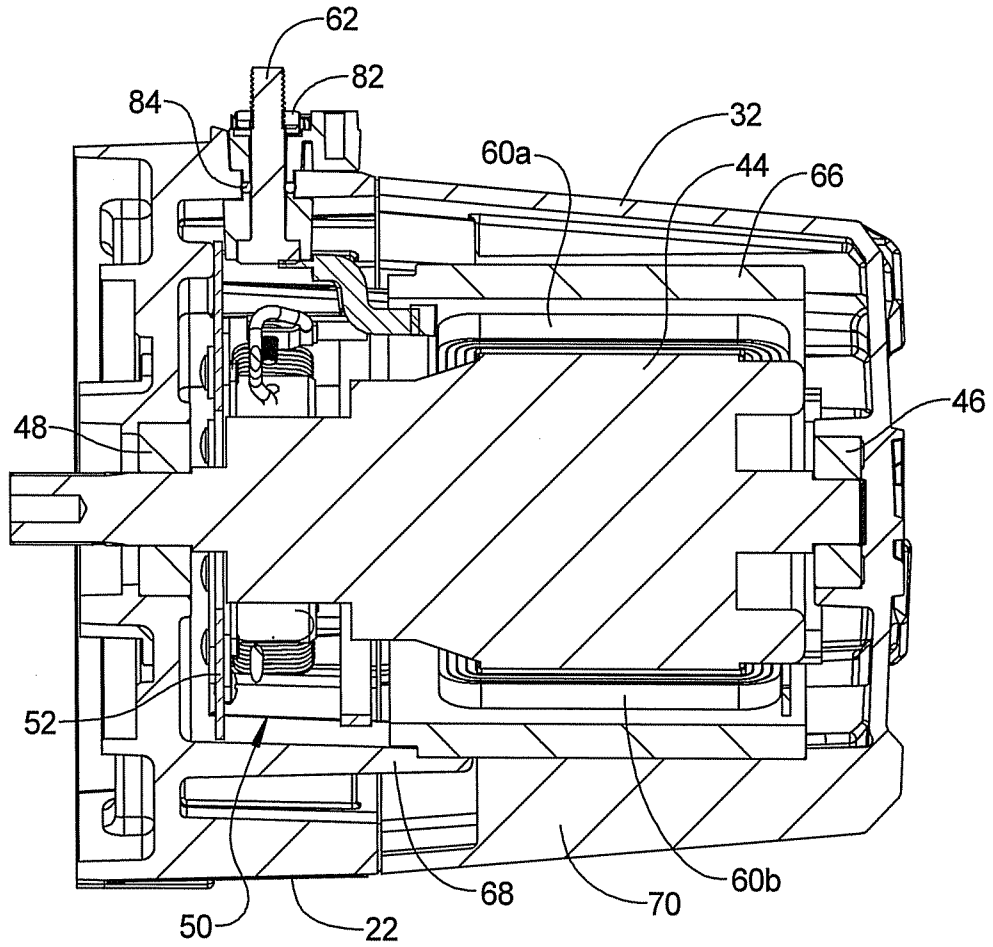

FIG 5

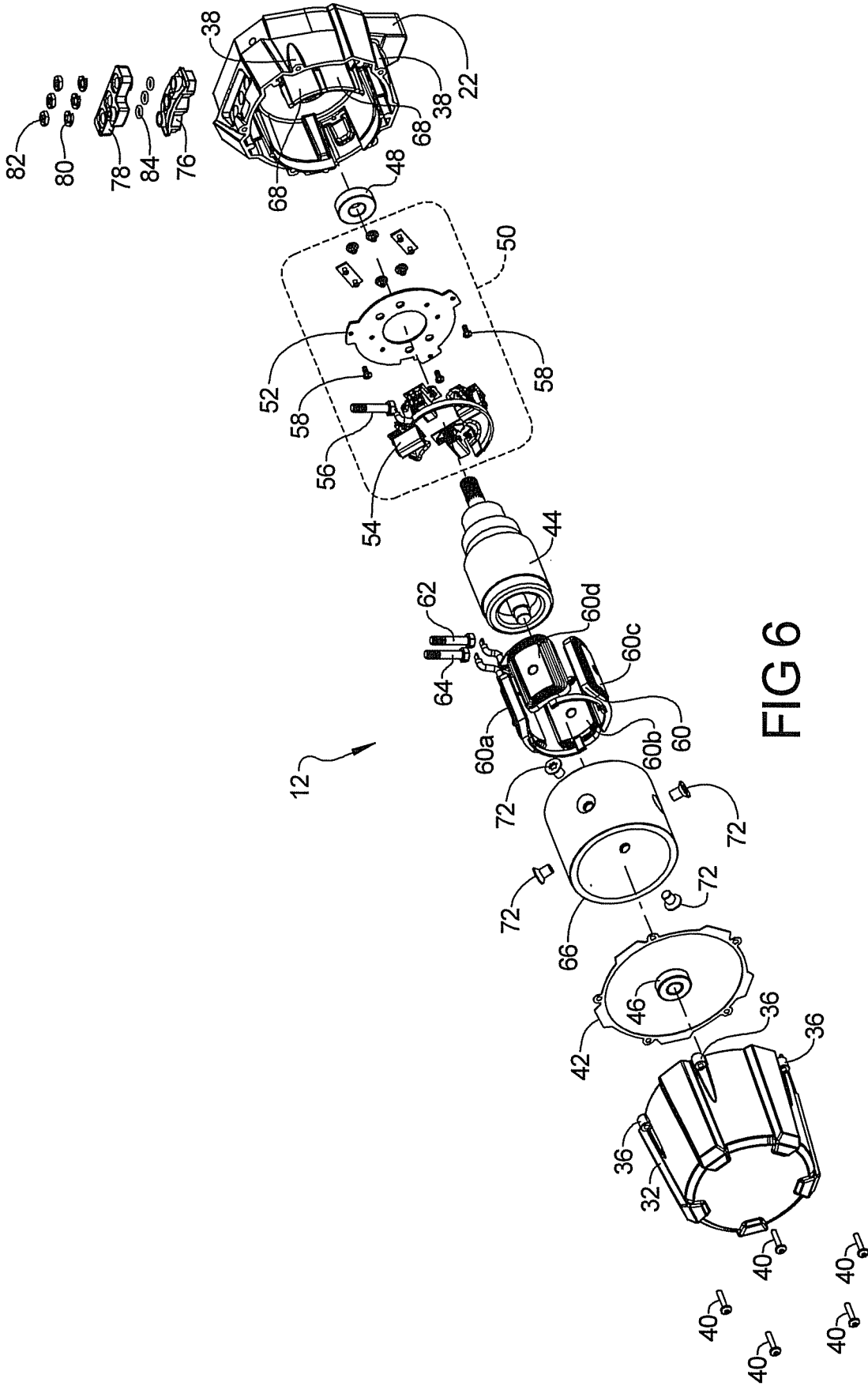

FIG 6

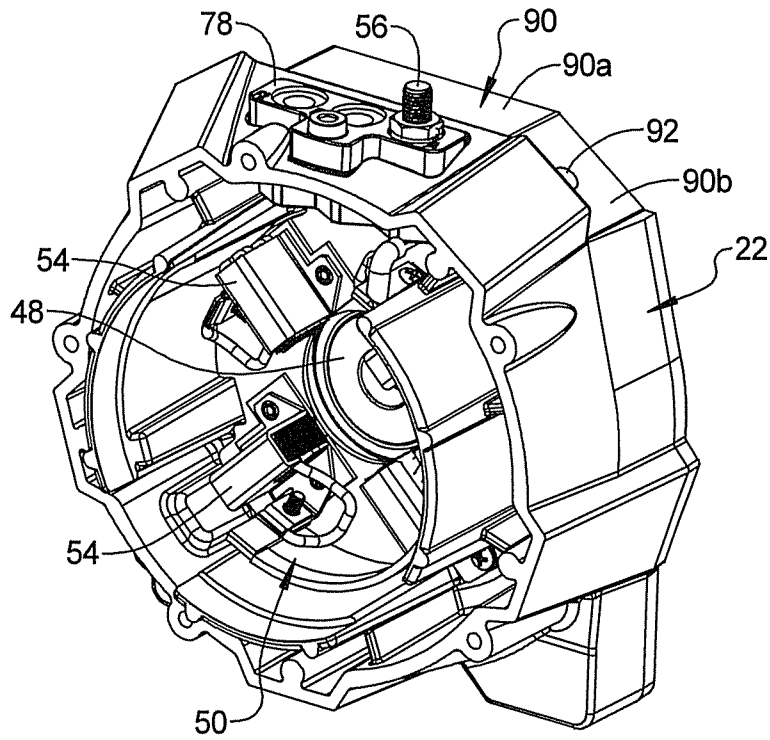

FIG 7

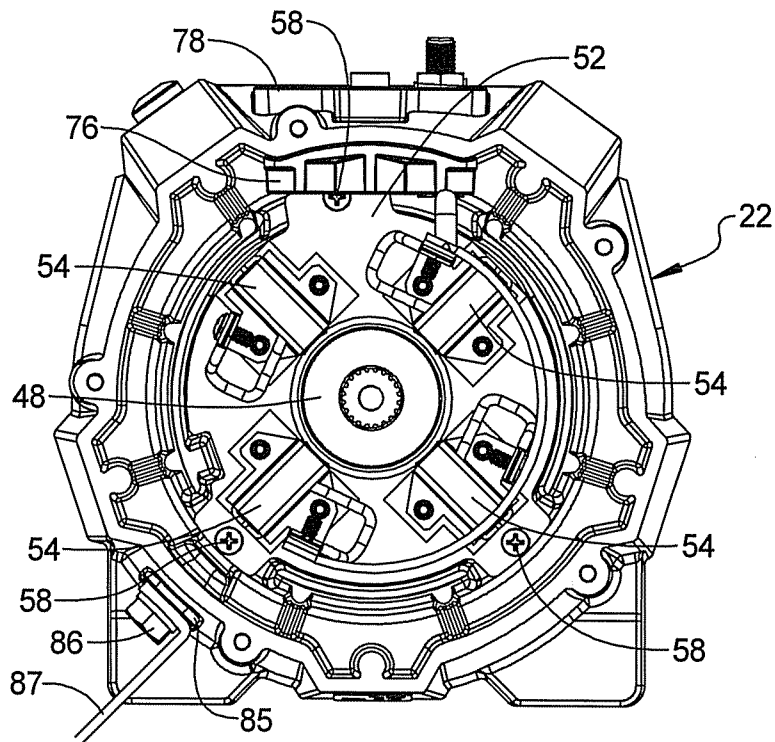

FIG 8

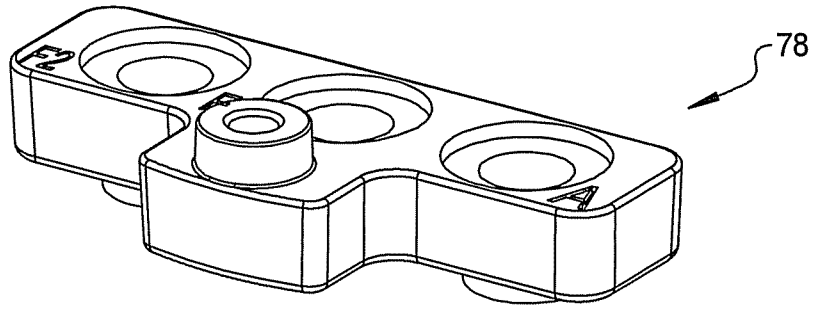

FIG 9

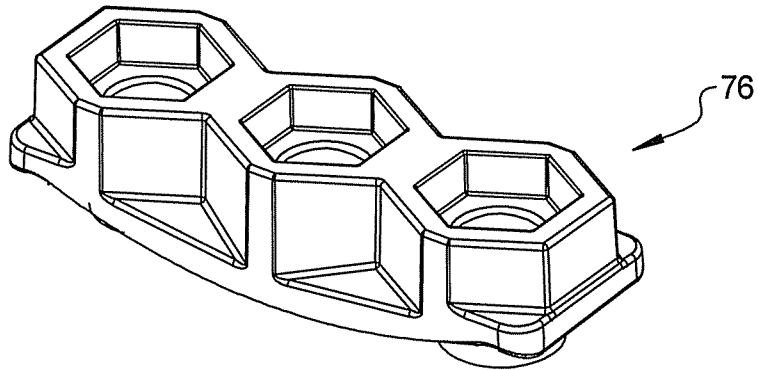

FIG 10

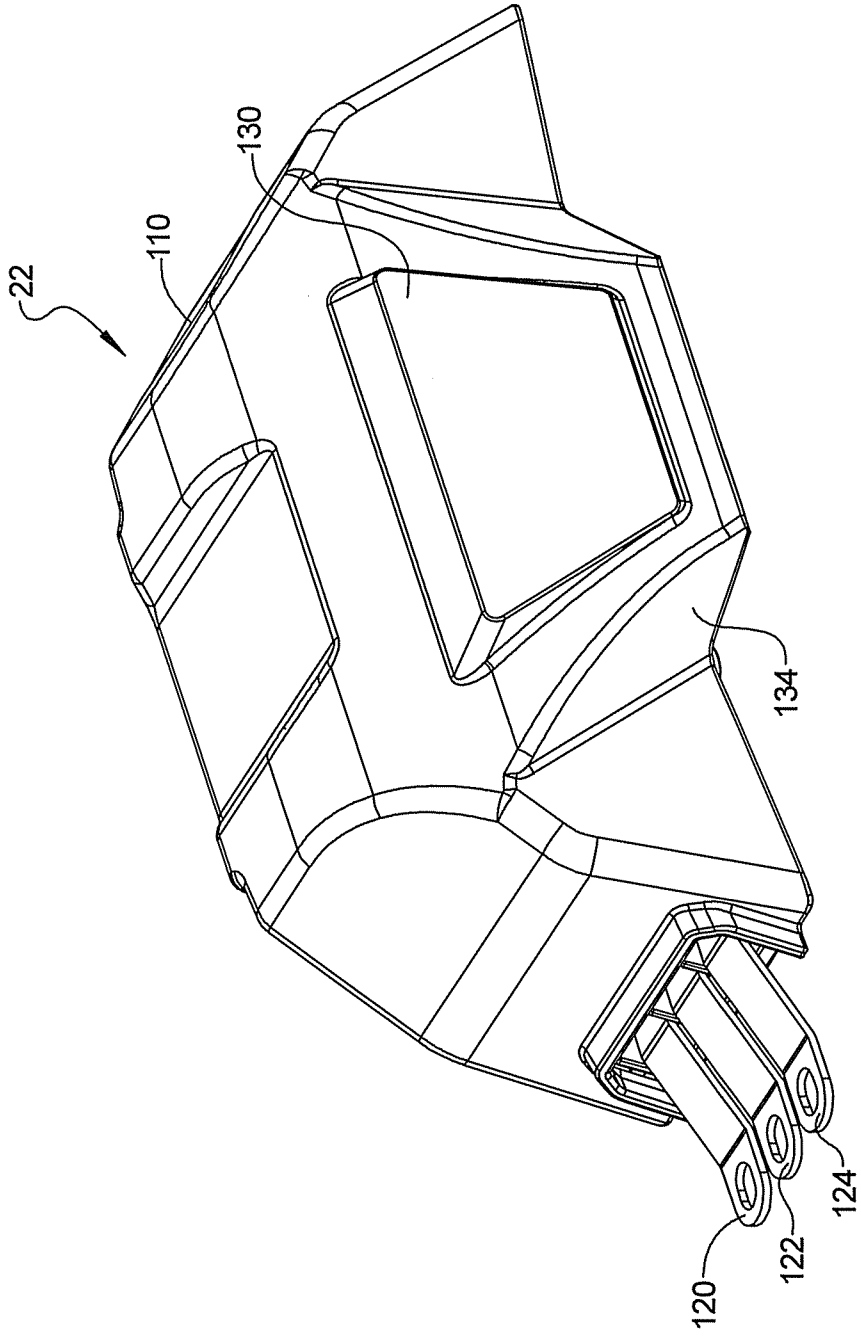

FIG 11

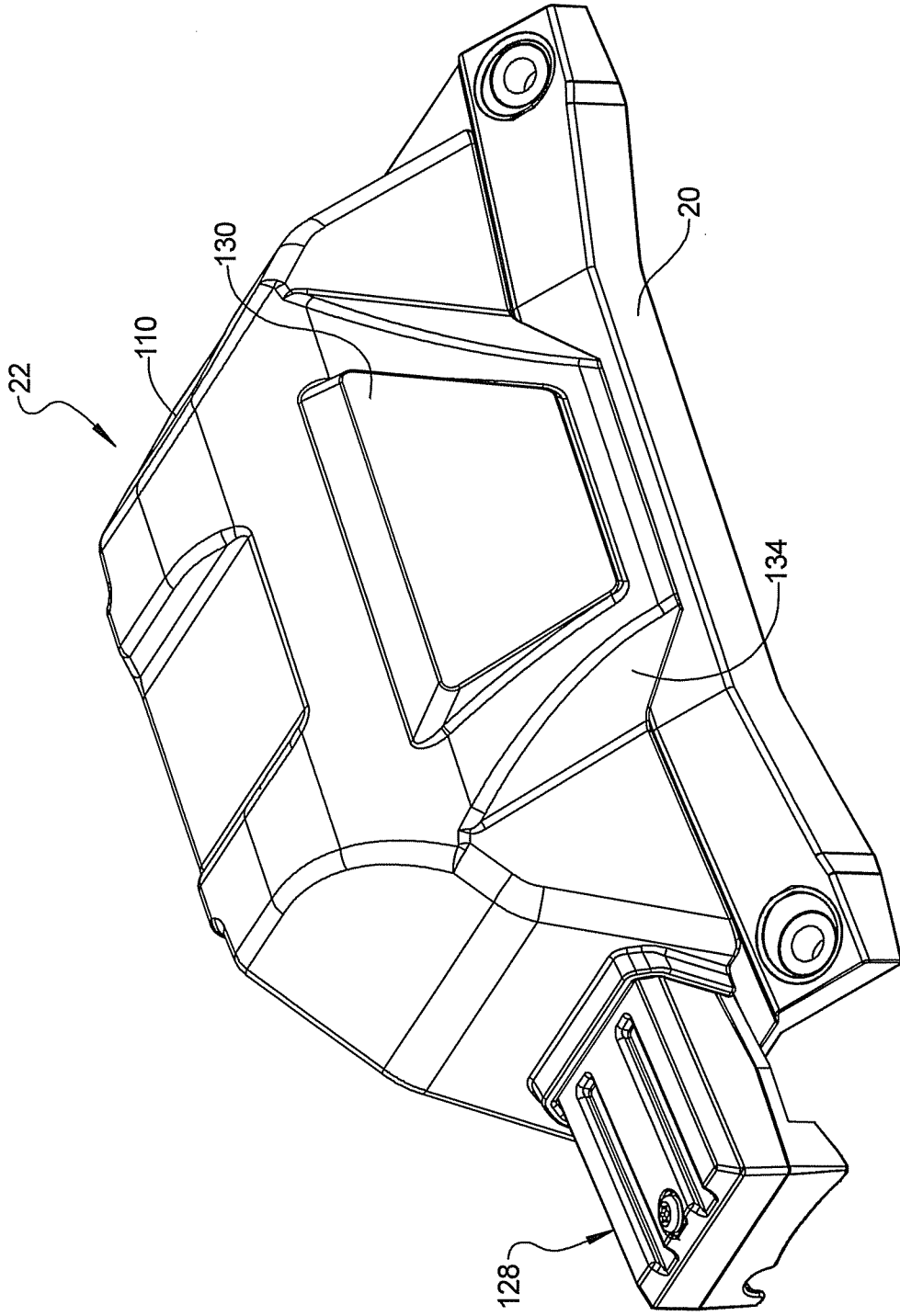

FIG 12

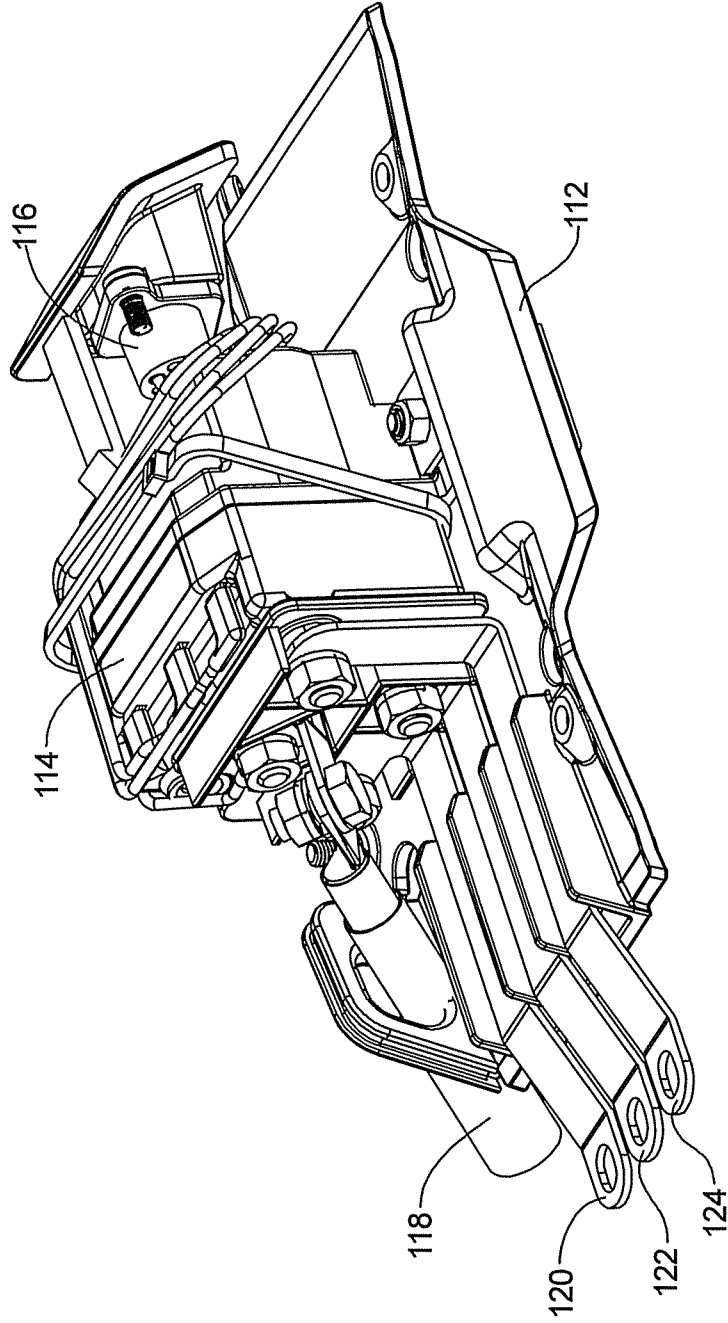

FIG 13

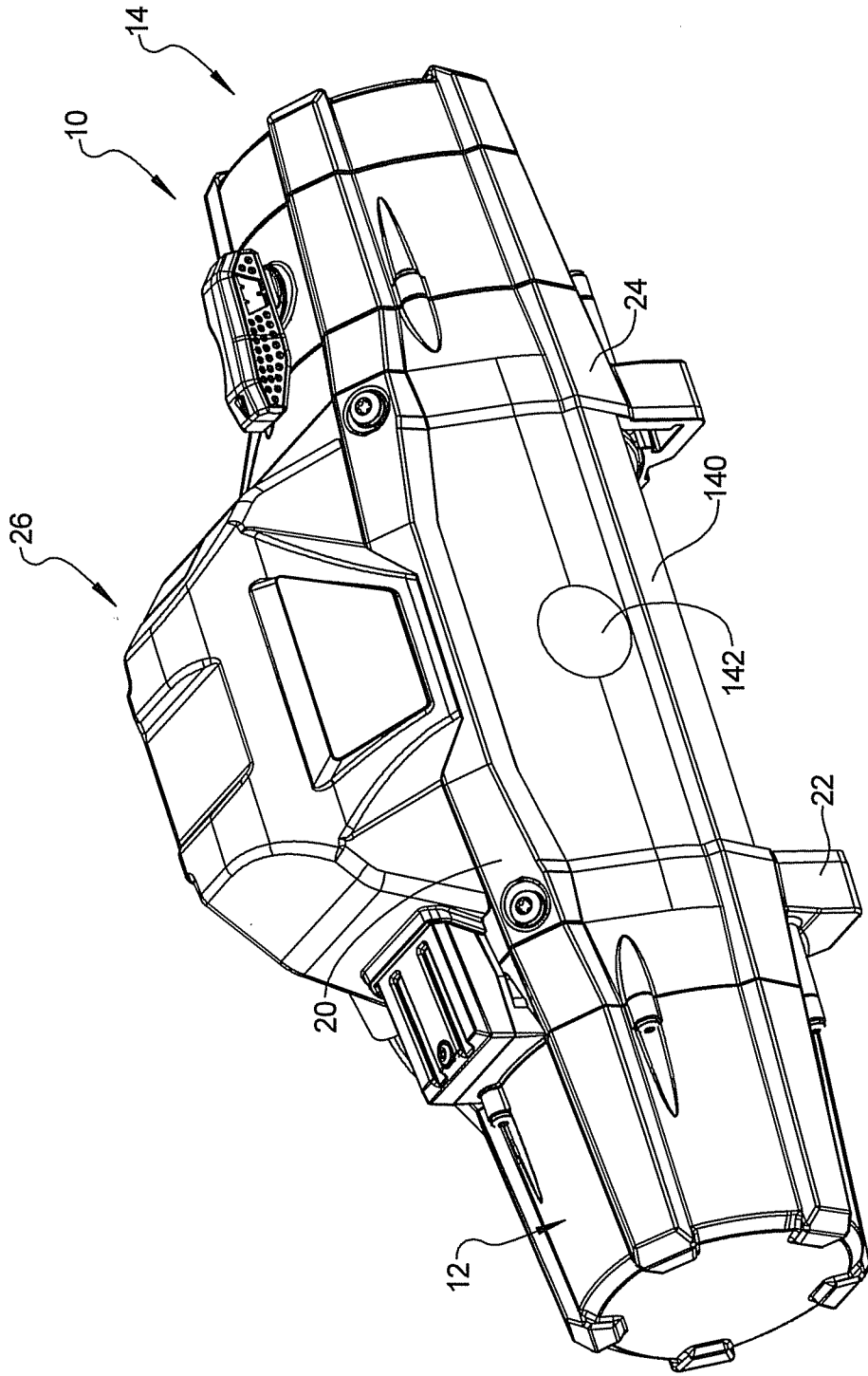

FIG 14

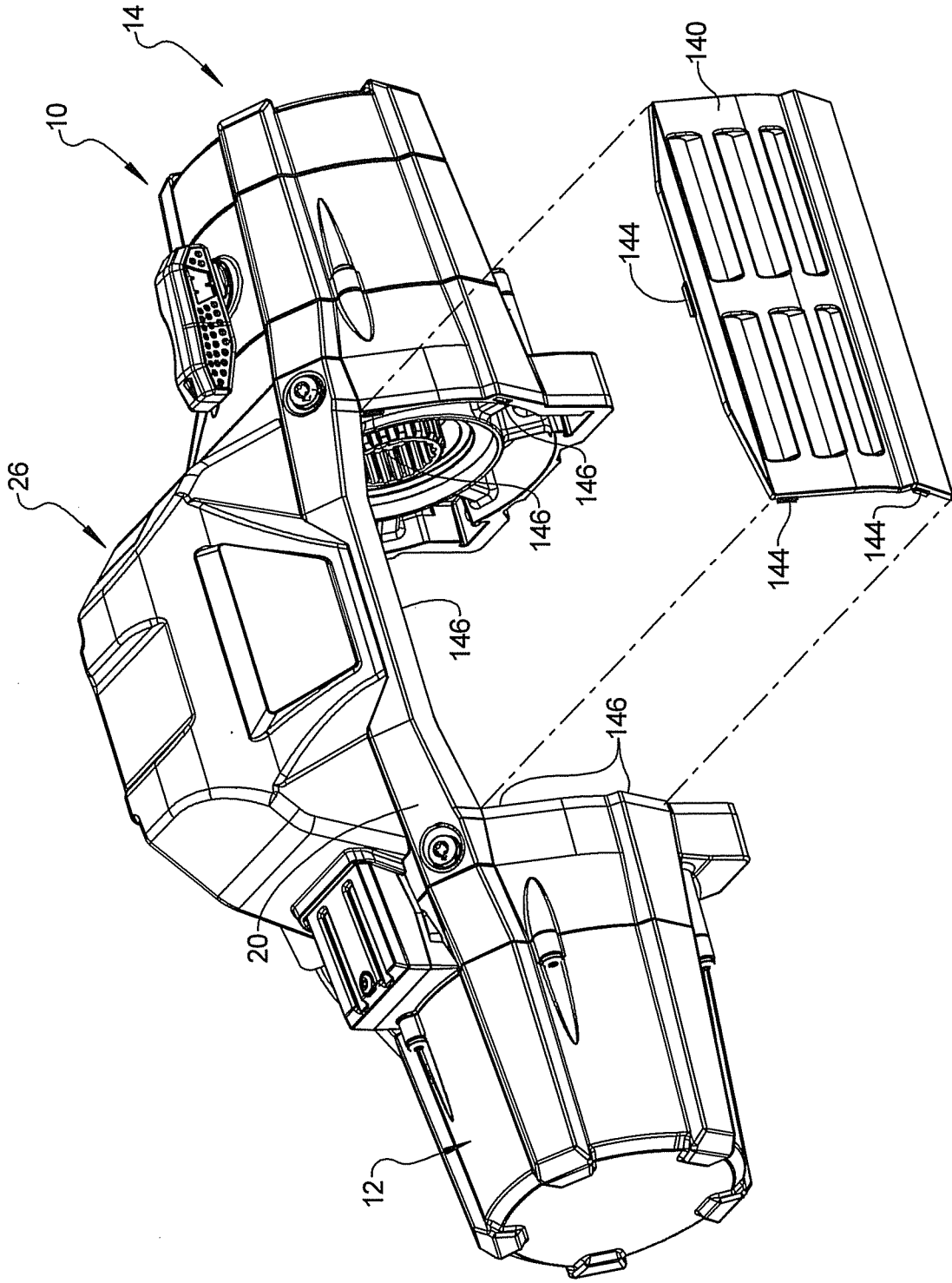

FIG 15