

No. 842,365.

PATENTED JAN. 29, 1907.

F. G. WISELOGEL.
SANITARY DUMP WAGON.
APPLICATION FILED OCT. 9, 1906.

2 SHEETS—SHEET 1.

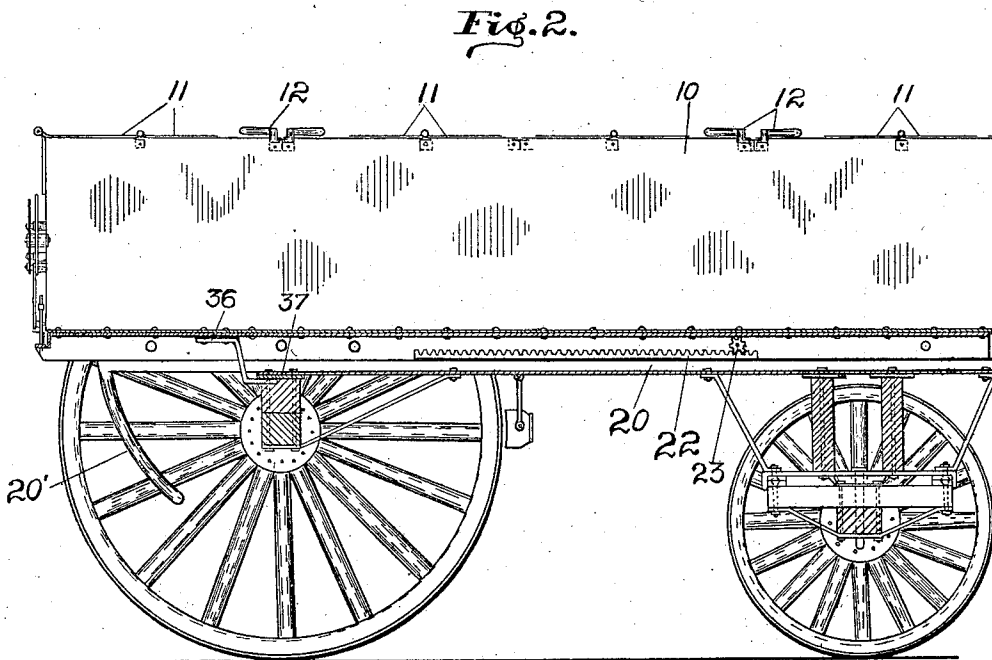
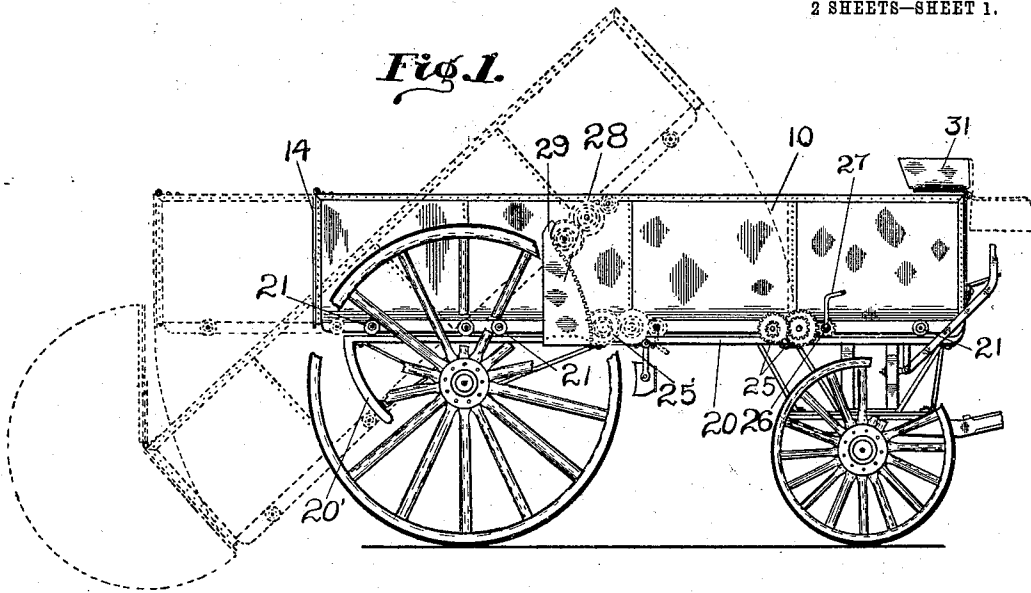

Witnesses
H. R. Glendening
Thomas H. McMeans

Inventor
Frederick G. Wiselugel.
Bradford Hood
Attorneys

No. 842,365.

PATENTED JAN. 29, 1907.

F. G. WISELOGEL.
SANITARY DUMP WAGON.
APPLICATION FILED OCT. 9, 1906.

2 SHEETS—SHEET 2.

Fig. 3.

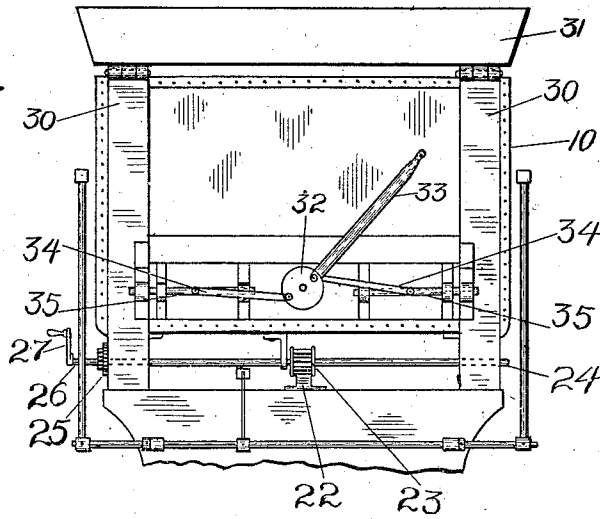
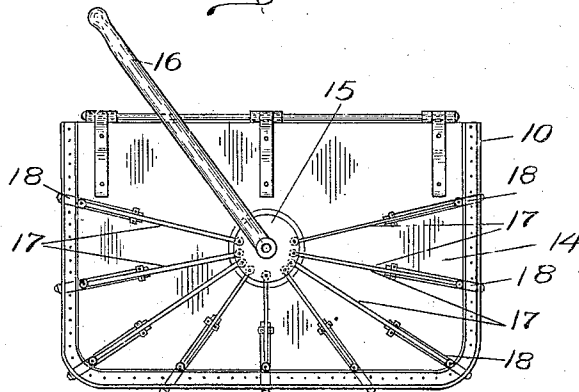

Fig. 4.



Witnesses
K. K. Henderson
Thomas H. McLean

Inventor
Frederick G. Wiselugel

By
Bradford Hood
Attorneys

UNITED STATES PATENT OFFICE.

FREDERICK G. WISELOGEL, OF INDIANAPOLIS, INDIANA, ASSIGNOR TO UNITED STATES CONSTRUCTION AND UTILIZATION COMPANY, OF ROCHESTER, NEW YORK, A CORPORATION OF NEW YORK.

SANITARY DUMP-WAGON.

No. 842,365.

Specification of Letters Patent.

Patented Jan. 29, 1907.

Application filed October 9, 1906. Serial No. 338,175.

To all whom it may concern:

Be it known that I, FREDERICK G. WISELOGEL, a citizen of the United States, residing at Indianapolis, in the county of Marion and State of Indiana, have invented certain new and useful Improvements in Sanitary Dump-Wagons, of which the following is a specification.

The object of my invention is to produce a wagon, more especially designed for hauling wet garbage, the construction being such that the contents may be readily dumped.

The accompanying drawings illustrate my invention.

Figure 1 is a side elevation; Fig. 2, a longitudinal vertical section; Fig. 3, a front elevation; Fig. 4, a rear elevation.

In the drawings, 10 indicates a main body or reservoir having the usual hinged covers 11, provided with suitable fastening means 12. The rear end of the body 10 is closed by means of an end-gate 14, supported upon horizontal hinges at its upper edge. Any desired means may be provided for clamping the end-gate in position to make a water-tight closure; but I find a convenient means to be that shown in detail in Fig. 4. In this construction a disk 15 is pivoted upon the end-gate at about its center and provided with an operating-lever 16, by means of which it may be rocked about its pivot. Radiating from plate 15 is a plurality of links 17, each of which is pivotally connected to a sliding bolt 18, mounted in suitable bearings on the end-gate and adapted to be projected into openings formed in adjacent sides and bottom of the body 10, the bolts being preferably wedge-shaped at their ends in order to force the end-gate home to its seat.

The running-gear carries a pair of longitudinal tracks 20, each of which at its rear end terminates in an arc-shaped downward extension 20'. The tracks 20 are adapted to receive and support rollers 21, carried by the main body 10, thus supporting the main body 10 upon the running-gear. The running-gear also carries an intermediate longitudinal rack 22, adapted to receive a pinion 23, carried by a cross-shaft 24, journaled in suitable bearings carried by the under side of body 10. Shaft 24 is driven by means of a

train of gears 25 from an operating-shaft 26, provided with an operating-crank 27, the arrangement being such that by rotating the crank-shaft the pinion 23 may be rotated and caused to travel along the rack 22, and thus propel the main body 10 forward or backward on the running-gear. Arranged in the path of movement of the gear 25' of each of the trains 25 is a substantially vertical segmental rack 28, terminating in a stop-finger 29.

The running-gear at its forward end is provided with a pair of uprights 30, adapted to support a seat 31, said seat being hinged thereto and adapted to be folded back over the forward end of the main body 10 when in normal position. In order to hold the main body 10 in ordinary transporting position, I mount upon the forward end thereof a disk 32, operated by means of a lever 33. Disk 32 carries a pair of oppositely-extending links 34, each of which is connected at its outer end to a sliding bolt 35, mounted upon the forward end of the main body 10 and adapted to be projected into suitable openings formed in the uprights 30. The rear end of body 10 is provided with a downwardly and forwardly extending hook 36, which when the body 10 is projected to its extreme forward position will pass under a cross-bar 37, which forms a part of the running-gear, thus holding the rear end of the main body 10 down upon the running-gear.

In operation the normal transporting position is indicated in full lines in Fig. 1. When it is desired to dump the contents, the rear door is released by swinging lever 16, so as to withdraw the several bolts 18. Thereupon the operator by turning crank 27 rotates shaft 24 and pinion 23, so as to drive the reservoir backward along the running-gear until gears 25' come into mesh with the segments 28, whereupon further rotation of the crank will cause the gears 25' to ride upward over the segments 28, and thus tilt the reservoir, as indicated in dotted lines in Fig. 1, the gate 14 swinging freely, so as to permit the material to flow out from the reservoir. During the dumping movement one of the rollers 21 on each side of body 10 rides down along the extensions 20', so that the gears 25' are held

in mesh with segments 28. By reversing the direction of rotation of the crank-shaft the parts will be returned to normal position.

I claim as my invention—

- 5 1. In a dumping-wagon, the combination, with the running-gear, of a receptacle movably mounted thereon, a longitudinal rack carried by the running-gear, a pinion carried by the receptacle and meshing with said rack,
 10 means for rotating said pinion, a segmental rack carried by the running-gear, and a pinion carried by the receptacle and adapted to be brought into engagement with the segmental rack.
- 15 2. In a dumping-wagon, the combination, with the running-gear, of a longitudinal track having a downward extension at its rear end, an upwardly-extending segmental rack arranged in opposition to said extension, a receptacle movably supported on the track and having a member adapted to engage the said extension, a longitudinal rack carried by the running-gear, a pinion carried by the receptacle and meshing with said rack, a pinion
 20 carried by the running-gear and adapted to mesh with the vertical segment, means for rotating said pinions, and means for holding the receptacle in normal receiving position.
- 25 3. In a dumping-wagon, the combination,

with the running-gear, of a receptacle reciprocally mounted thereon, a vertical rack carried by the running-gear, a pinion journaled on the receptacle and adapted to be brought into mesh with the rack, means for propelling the receptacle longitudinally on the running-gear, and a single means for operating the said propelling means and the rack-engaging pinion.

4. In a dumping-wagon, the combination, with the running-gear, of a receptacle reciprocally mounted thereon, a vertical rack carried by the running-gear, a pinion journaled on the receptacle and adapted to be brought into mesh with the rack, means for propelling the receptacle longitudinally on the running-gear, a single means for operating the said propelling means and the rack-engaging pinion, and a downward extension carried by the running-gear in opposition to the vertical rack, and means carried by the receptacle to engage said extension.

In witness whereof I have hereunto set my hand and seal, at Indianapolis, Indiana, this 3d day of October, A. D. 1906.

FREDERICK G. WISELOGEL. [L. s.]

Witnesses:

ARTHUR M. HOOD,
 THOMAS W. McMEANS.